



NATIONAL AERONAUTICS AND SPACE ADMINISTRATION

MSC INTERNAL NOTE NO. 68-FM-106

May 1, 1968

APOLLO CSM AND LM ONBOARD NAVIGATION SYSTEM CONSTRAINTS

By T. J. Blucker,
Mathematical Physics Branch

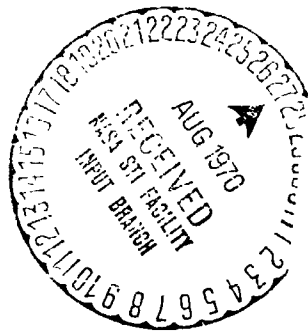

FACILITY FORM 602

N70-35773
(ACCESSION NUMBER)

23
(PAGES)

Tmx-65079
(NASA CR OR TMX OR AD NUMBER)

(THRU)

(CODE)

21
(CATEGORY)

MISSION PLANNING AND ANALYSIS DIVISION

MANNED SPACECRAFT CENTER
HOUSTON, TEXAS

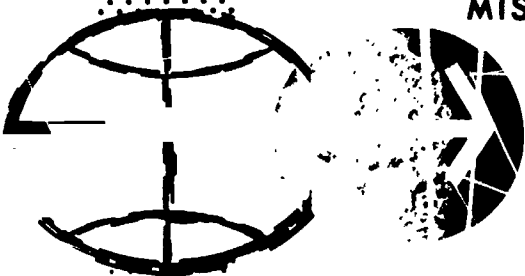

MSC INTERNAL NOTE NO. 68-FM-106

PROJECT APOLLO

APOLLO CSM AND LM ONBOARD
NAVIGATION SYSTEM CONSTRAINTS

By T. J. Blucker
Mathematical Physics Branch

May 1, 1968

MISSION PLANNING AND ANALYSIS DIVISION
NATIONAL AERONAUTICS AND SPACE ADMINISTRATION
MANNED SPACECRAFT CENTER
HOUSTON, TEXAS

Approved:

James C. McPherson, Chief
Mathematical Physics Branch

Approved:

John J. Mayer, Chief
Mission Planning and Analysis Division

CONTENTS

Section	Page
SUMMARY AND INTRODUCTION.	1
CSM NAVIGATION SYSTEM CONSTRAINTS	1
Sextant	1
Scanning Telescope.	4
Command Module COAS	4
LM ONBOARD NAVIGATION SYSTEM CONSTRAINTS.	5
Alignment Optical Telescope	5
Rendezvous Radar.	6
Lunar Module COAS	6
SIGHTING TIME CONSTRAINTS	7
REFERENCES.	18

PRECEDING PAGE BLANK NOT FILMED.

FIGURES

Figure		Page
1	CM optics coverage with IM attached (taken from ref. 13)	
	(a) Sextant	8
	(b) Scanning telescope.	8
2	AOT viewfield coverage (taken from ref. 5)	9
3	Radar antenna interference in AOT field of view (taken from ref. 6).	10
4	Shaft angle coverage in mode 1 (tracking and rendezvous; taken from ref. 8)	11
5	Shaft angle coverage in mode 2 (lunar stay; taken from ref. 8).	12
6	Trunnion angle coverage in modes 1 and 2 (taken from ref. 8).	13
7	Landmark viewing constraint (taken from ref. 9).	14
8	CM COAS adjustment capability (target at infinite distance; taken from ref. 11).	15
9	IM COAS forward window mount (X-axis; target at infinite distance; taken from ref. 12)	16
10	IM COAS forward window mount (Z-axis; target at infinite distance; taken from ref. 12)	17

FIGURES

Figure		Page
1	CM optics coverage with LM attached (taken from ref. 13)	8
2	AOT viewfield coverage (taken from ref. 5)	9
3	Radar antenna interference in AOT field of view (taken from ref. 6).	10
4	Shaft angle coverage in mode 1 (tracking and rendezvous; taken from ref. 8)	11
5	Shaft angle coverage in mode 2 (lunar stay; taken from ref. 8)	12
6	Trunnion angle coverage in modes 1 and 2 (taken from ref. 8).	13
7	Landmark viewing constraint (taken from ref. 9).	14
8	CM COAS adjustment capability (target at infinite distance; taken from ref. 11).	15
9	LM COAS forward window mount (X-axis; target at infinite distance; taken from ref. 12)	16
10	LM COAS forward window mount (Z-axis; target at infinite distance; taken from ref. 12)	17

APOLLO CSM AND LM ONBOARD NAVIGATION SYSTEM CONSTRAINTS

By T. J. Blucker

SUMMARY AND INTRODUCTION

This report presents the current constraints for the Block II CSM and LM navigation systems for both the earth orbital and lunar orbital onboard computer programs. These constraints supersede those given in reference 1 and will be updated as the need arises. They were compiled for the Mathematical Physics Branch to use in evaluating the onboard navigation systems for manned Apollo missions and are presented for others who may find them helpful in mission planning.

A sextant, a scanning telescope, and a crewman optical alignment sight (COAS) are available on the CSM to take measurements for use in the CSM onboard navigation system. The LM onboard navigation system may accept measurement from an alignment optical telescope (AOT), a rendezvous radar (RR), and a COAS.

Constraints for these must be associated with the particular onboard computer program used. For the early earth orbital mission, the program SUNDISK is used in the CM computer and the program SUNDANCE in the LM computer. For the lunar missions, these programs will be replaced by COLOSSUS (in the CSM) and LUMINARY (in the LM). Current plans are to introduce COLOSSUS in Mission D and LUMINARY in Mission E.

CSM NAVIGATION SYSTEM CONSTRAINTS

Sextant

The sextant, a high magnification (28X), narrow viewfield (1.8°), dual-line-of-sight device, is used for sightings to determine one of the following:

- a. Line-of-sight direction to stars for determining inertial measurement (IMU) orientation.
- b. Line-of-sight direction to LM for rendezvous navigation.

c. Angle between star and a lunar or earth horizon for midcourse navigation.

d. Angle between star and a lunar or earth landmark for midcourse navigation.

e. Line-of-sight direction to lunar and earth landmark for orbital navigation.

If a line-of-sight direction to the target is to be determined, as in a, b, and e, by the sextant (or the scanning telescope - see next section), the target is required to be in the center of the viewfield. For measurements of the types c and d, the two targets are required to be superimposed on one another but not necessarily at the viewfield center. The maximum allowable displacement of the target from the center of the viewfield at acquisition is illustrated in figure 1. The shaded area represents diminishing brightness of the target from the inside of the circle to total loss at the outside circle. This shaded area is useful for bright targets such as bright stars, landmarks, horizons, and the LM when the CM is near it. The CM programs currently have two types of optics coverage constraints programmed so that an alarm light is flashed if they should be exceeded. One of the constraints is imposed by the automatic optics routine, and the other is imposed by the astronaut manually manipulating the sextant. These constraints, in radius of a cone, are as follows for the CM SUNDISK program:

a. Auto optics - 38° , when sighting the LM for rendezvous; 90° , when tracking any target other than the LM.

b. Manual optics - 38° for any target.

For the CM COLOSSUS program they are as follows:

a. Auto optics - 50° , when sighting LM for rendezvous; 90° , when sighting any target other than the LM.

b. Manual optics - 50° for any target.

The alarm flashing would suggest an attitude change.

The coverage of the sextant is defined in figure 1(a) as a cone about the optics Z-axis. This axis is in the spacecraft X-Z body axes plane approximately 33° above the Z-body axis.

An occultation cone is set for the earth, moon and sun in the star selection routine for both SUNDISK and COLOSSUS for sextant star sightings. The half-angle dimensions (ref. 2) of these occultation cones for SUNDISK are:

- a. Earth - 80°
- b. Moon - 5°
- c. Sun - 30°

In COLOSSUS the occultation cones for the sextant are a function of CM position and are set at a specified angle from the star to the near horizon or the center of the body. These angles (ref. 3) are as follows in the earth sphere of influence:

- a. Sun - 15° from center.
- b. Earth - 5° from near horizon.
- c. Moon - 5° from center.

In the lunar sphere of influence they are:

- a. Sun - 15° from center.
- b. Earth - 5° from center.
- c. Moon - 5° from near horizon.

These constraints should also be assumed for sighting on stars for midcourse navigation (star-landmark and star-horizon).

A pair of stars selected by the star selection routine for IMU alignment are constrained as follows:

- a. SUNDISK - must be between 40° and 66° apart (ref. 2).
- b. COLOSSUS - must be between 30° and 76° apart (obtained from Robert L. White of MIT).

For star-landmark and star-horizon observations, stars should be of magnitude 1 or brighter (obtained from Charles Manry of G&C Division). ?

Although IMU alignment and midcourse navigation can be performed manually, it is recommended that the "auto-optics" routine be used for star acquisition to conserve reaction control system (RCS) fuel.

The LM tracking light is a high-intensity beacon which is the source of CM sextant tracking. The beacon visibility may be represented as a cone half-vertex angle of 30° about the LM + Z axis (ref. 6). The range of visibility is defined as follows:

- a. Visual (or scanning telescope), 130 n. mi. (ref. 6).
- b. Sextant, 400 n. mi. *maybe!*

Scanning Telescope

The scanning telescope, a unity power, wide viewfield (60°), single-line-of-sight device is used for coarse acquisition prior to sighting with the sextant, for alignment of the IMU stable member to back up the sextant, or for determining the line-of-sight direction to landmarks for orbital navigation. The effective coverage of the telescope is also illustrated in figure 1(b) as a cone about the Z optics axis. The shaded area in the scanning telescope coverage, as illustrated in figure 1(b), is useful for bright targets, as previously mentioned for the sextant.

The programs occultation checks are designed for sextant use and are not necessarily applicable for the telescope. Operational constraints for using the telescope, however, are estimated as follows:

- a. Minimum angles from the vehicle line of sight to the sun line is 60° for star sightings (ref. 4).
- b. IMU alignment sightings must be performed in the spacecraft shadow using the telescope (ref. 4).

The following landmark constraints were given by Tom Parr of MIT. They reflect the requirements now defined for deep-space, lunar, and earth orbit tracking (ref. 9).

- a. The landmark must be illuminated and be of high contrast.
- b. The line of sight to the landmark must make an angle of no more than 45° with the vertical (fig. 7).

Command Module COAS

The CM COAS is a compact, unity powered, 10° field-of-view instrument which may be used for a degraded alignment of the IMU if the scanning telescope becomes ineffective at identifying stars. The adjustment capability of the CM COAS (fig. 8) from the null position (along the X-body axis) ranges from -10° to 31.5° from the CM X-Y plane measured in the X-Z plane - motion from +X to +Z being negative (ref. 11). This coverage is with no LM attached as an attached LM would block practically the entire field of view.

LM ONBOARD NAVIGATION SYSTEM CONSTRAINTS

Alignment Optical Telescope

The AOT is a unity-power telescope with a 60° field of view. The AOT has six sighting positions with which to make star sightings. Three forward positions are illustrated in figure 2, and three more are available in positions which could be illustrated by a mirror image of those.

Its function is to assist in determining the LM stable member (IMU) alignment by measuring the azimuth and elevation angles to stars in the navigation base coordinates. The AOT field of view is partially obstructed in the forward position by the rendezvous radar antenna and by the the CM when the AOT is attached in the forward right and forward left positions, as illustrated in figure 3. Operational constraints on the AOT include the following minimum angles from the instrument line of sight to the sun, earth and moon.

When the LM is in the earth sphere of influence and SUNDANCE is used (ref. 5), the constraints are:

- a. Sun - 90° from sun line.
- b. Earth - 5° from near horizon as computed.
- c. Moon - 5° from lunar line.

When the LM is in the lunar sphere of influence and LUMINARY is used, the constraints are:

- a. Sun - 90° from sun line.
- b. Earth - 5° from earth line.
- c. Moon - 5° from near horizon as computed.

The AOT occultation checks were set for SUNDANCE assuming the AOT sun shield was not attached. Although the shield will be attached on all manned LM's, it may be too late to alter the sun occultation in the SUNDANCE program. The operational constraint for sun occultation for a shielded AOT is estimated to be 60° from the sun line. Robert L. White of MIT has requested this occultation alteration be made for the LUMINARY program, and the earth and moon checks will remain the same as in SUNDANCE, as given above.

The constraints in the earth sphere of influence for LUMINARY (ref. 5) are:

- a. Sun - 60° from sun line.
- b. Earth - 5° from near horizon.
- c. Moon - 5° from near horizon.

In the lunar sphere of influence, the constraints (ref. 5) are:

- a. Sun - 60° from sun line^a.
- b. Earth - 5° from near horizon.
- c. Moon - 5° from near horizon.

A pair of stars selected by the star alignment routine for IMU alignment are constrained as follows (ref. 5):

- a. SUNDANCE - must be between 50° and 100° apart.
- b. LUMINARY - must be between 50° and 100° apart.

Rendezvous Radar

The rendezvous radar onboard the LM can track a transponder onboard the CSM. It provides the astronaut and the LM Guidance Computer (LGC) with the range, range rate, and angles of the corresponding target between 80 ft and 400 n. mi. (ref. 7). In mode 1 (i.e., the LM rendezvous radar is tracking in flight) the total coverage is defined in figures 4 and 6 (ref. 8). In mode 2 (i.e., the LM rendezvous radar is tracking while on the Lunar surface) the coverage is defined in figures 5 and 6 (ref. 8).

Lunar Module COAS

The LM COAS (ref. 12) is a unity powered, 10° field-of-view instrument with 1° of movement which may be used to align the LM in the event of an inoperative AOT. It can be mounted on the commander's side in either the overhead window (X-axis mount) or the forward window (Z-axis mount).

^aRequested change from 90° .

When mounted in the overhead window, the instrument line of sight can be rotated about an axis parallel to the LM Y-axis from a zero position parallel to the LM +X axis, 35° toward the LM +Z axis, or 5° toward the LM (-Z) axis (fig. 9).

When mounted in the forward window, the instrument line of sight can be rotated about an axis parallel to the LM X-axis 40° to either side of a zero position (fig. 10).

Based on Gemini experience with a similar instrument, it is estimated that either the CM or LM COAS line of sight will be constrained to be 90° from the sun line.

SIGHTING TIME CONSTRAINTS

The following times were established for specific astronaut tasks from talking with members of the Crew Safety and Procedures Branch of Flight Crew Division (ref. 10). These times represent this branch's best estimate for navigation "dead times", that is, times during which no sightings or measurements may be made.

The dead times for optics sightings are

- a. 10 minutes prior to until 6 minutes after the SPS burn.
- b. 4 minutes after RCS burn.
- c. 13 minutes prior to the terminal phase initiation (TPI) burn.
- d. 7 minutes prior to the midcourse correction (MCC) burn.
- e. 10 minutes prior to terminal phase finalization (TPF) burn.

The dead times for rendezvous radar measurements are

- a. 10 minutes prior to until 4 minutes after the ascent propulsion system (APS) burn.
- b. 7 minutes prior to reaction control system (RCS) burns.
- c. 2 minutes after RCS burns.

IMU alignment times were established from crew simulations in Block I hardware at North American in Los Angeles, but these times should be the same for Block II vehicles. The time required to align the IMU in the CSM is 13 minutes, which includes 3 minutes for the pilot to move from his couch to the navigation bay. LM IMU alignment is done at the pilot's couch and requires 10 minutes.

/// LM INTERFERENCE
WHEN DOCKED
AREA OF DIMINISHED
BRIGHTNESS

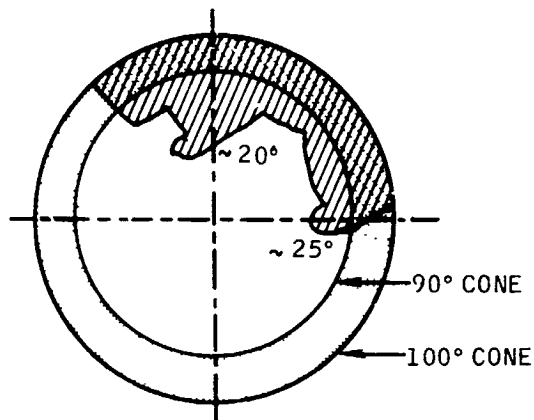

(a) SEXTANT

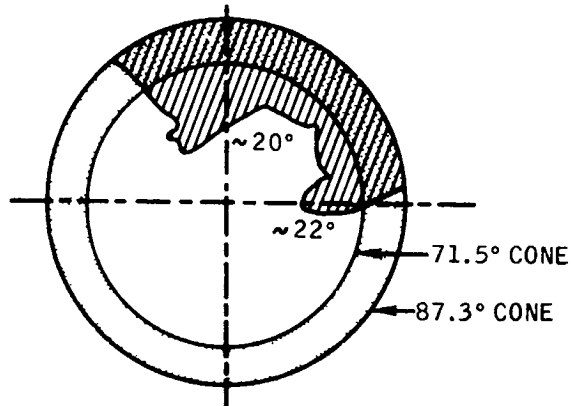

(b) SCANNING TELESCOPE

Figure 1.- CM optics coverage with LM attached (taken from ref. 13).

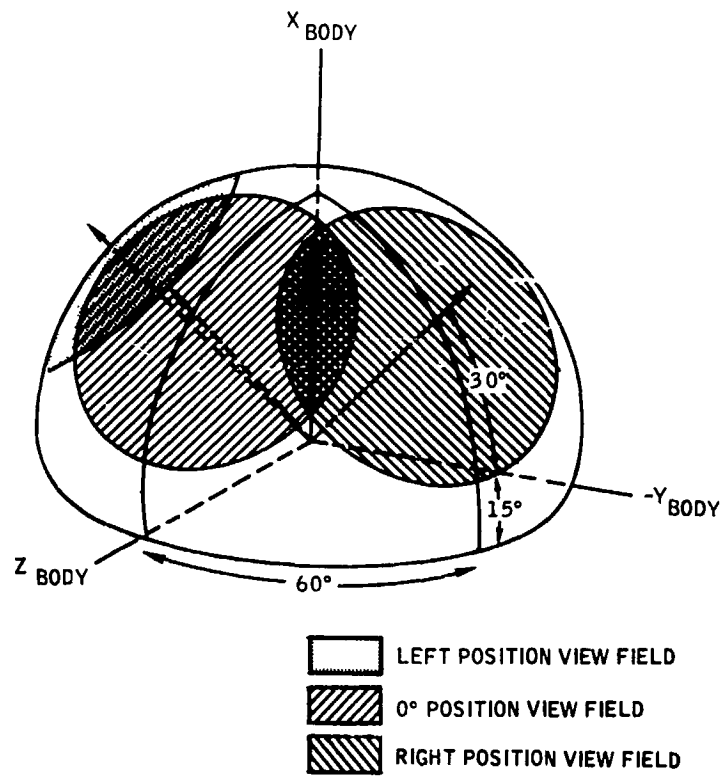

Figure 2.- AOT viewfield coverage (taken from ref. 5).

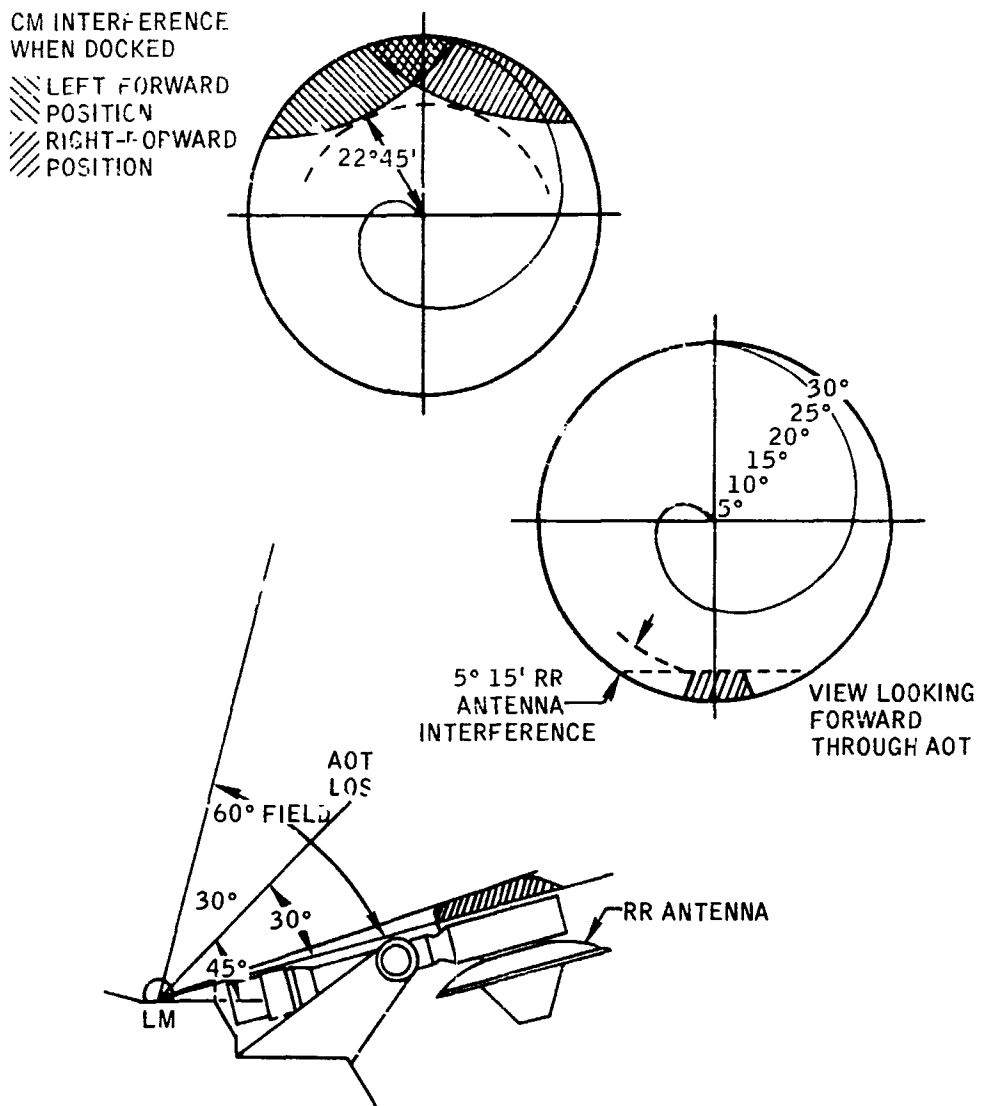

Figure 3.- Radar antenna interference in AOT field of view (taken from ref. 6).

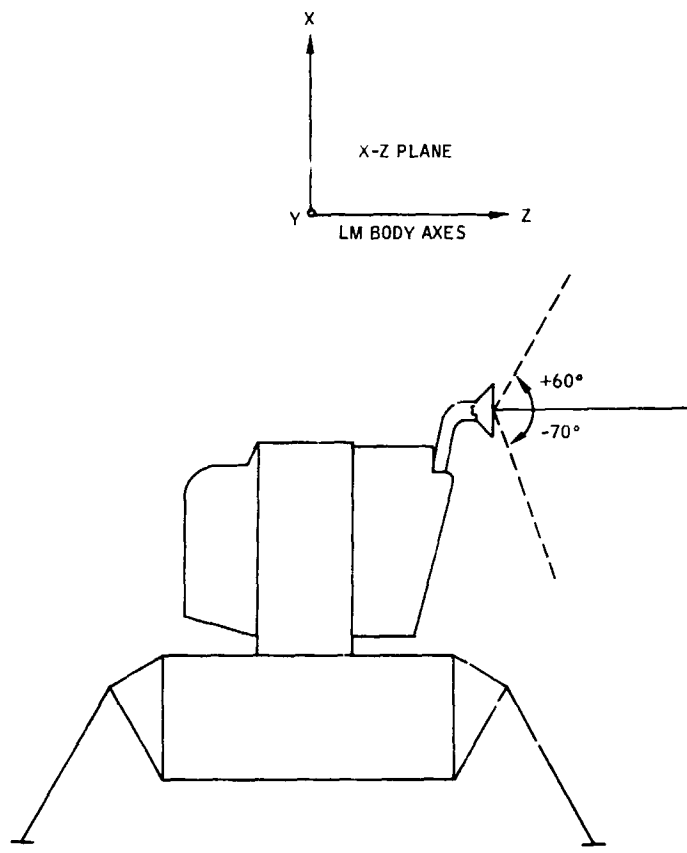

Figure 4.- Shaft angle coverage in mode 1 (tracking and rendezvous; taken from ref. 8).

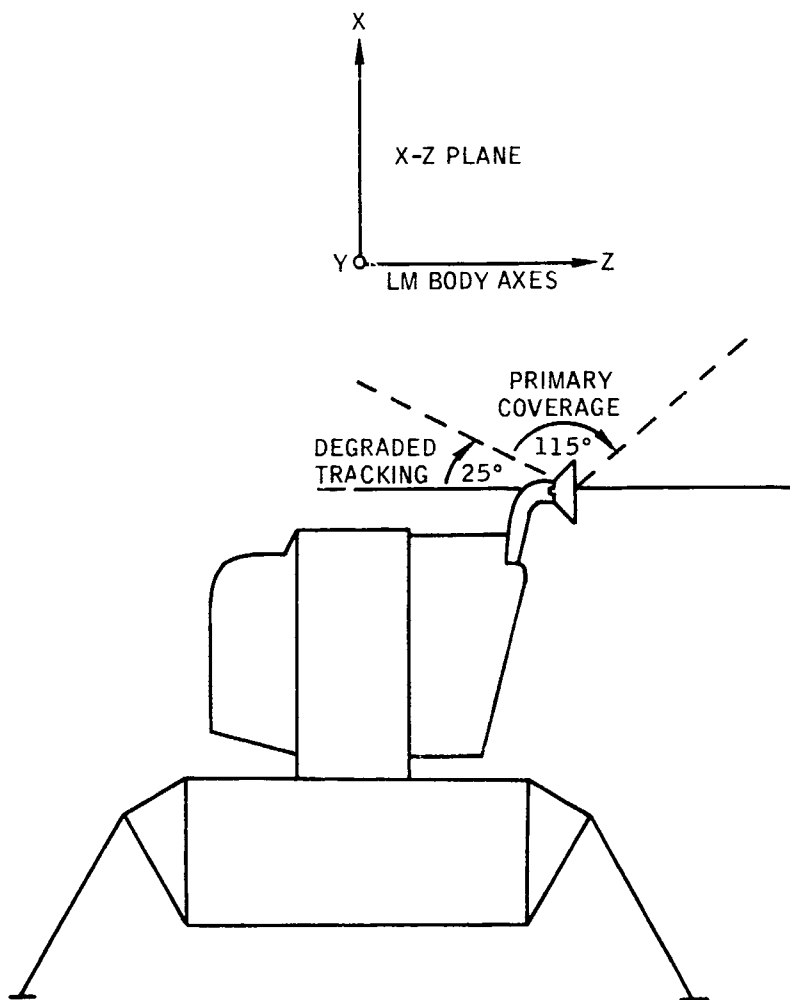

Figure 5.- Shaft angle coverage in mode 2 (lunar stay; taken from ref. 8).

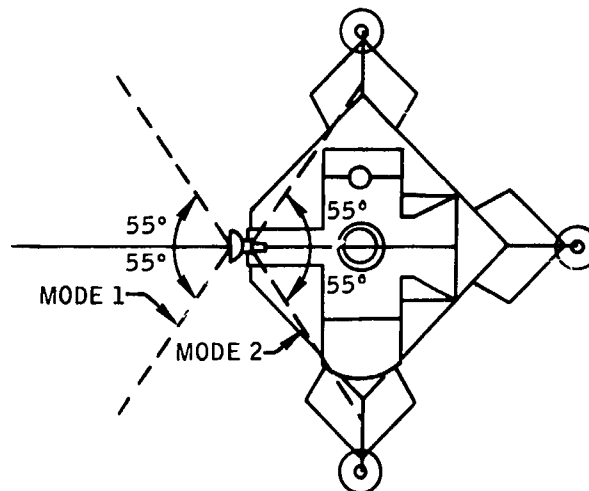
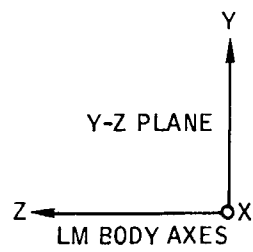

Figure 6.- Trunnion angle coverage in modes 1 and 2 (taken from ref. 8).

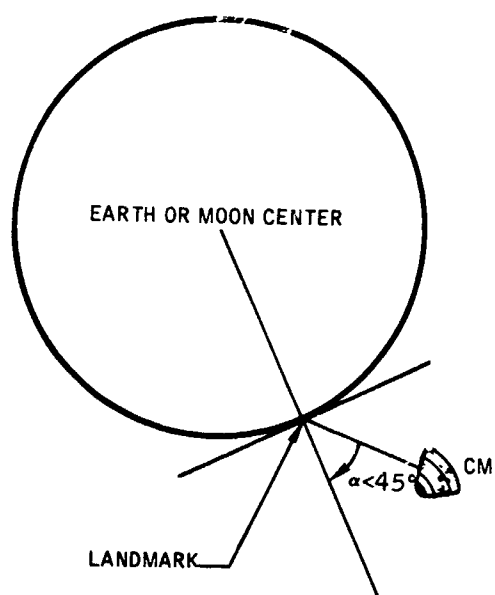

Figure 7.- Landmark viewing constraint (taken from ref. 9).

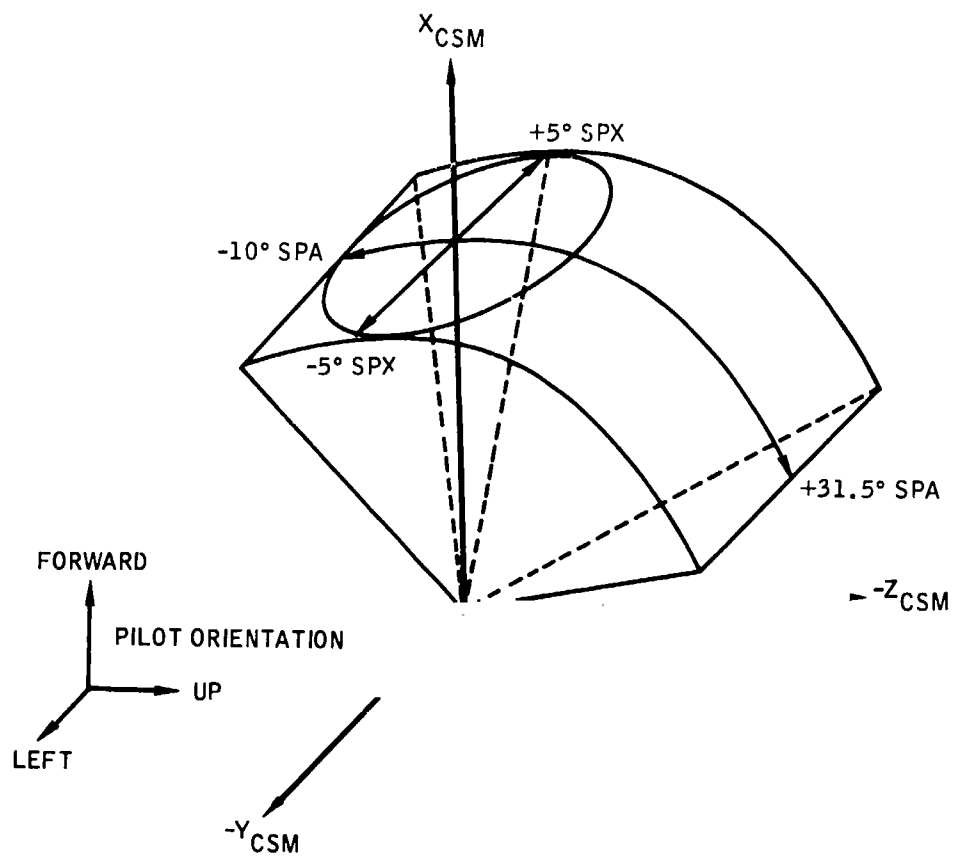

Figure 8.- CM COAS adjustment capability (target at infinite distance; taken from ref. 11).

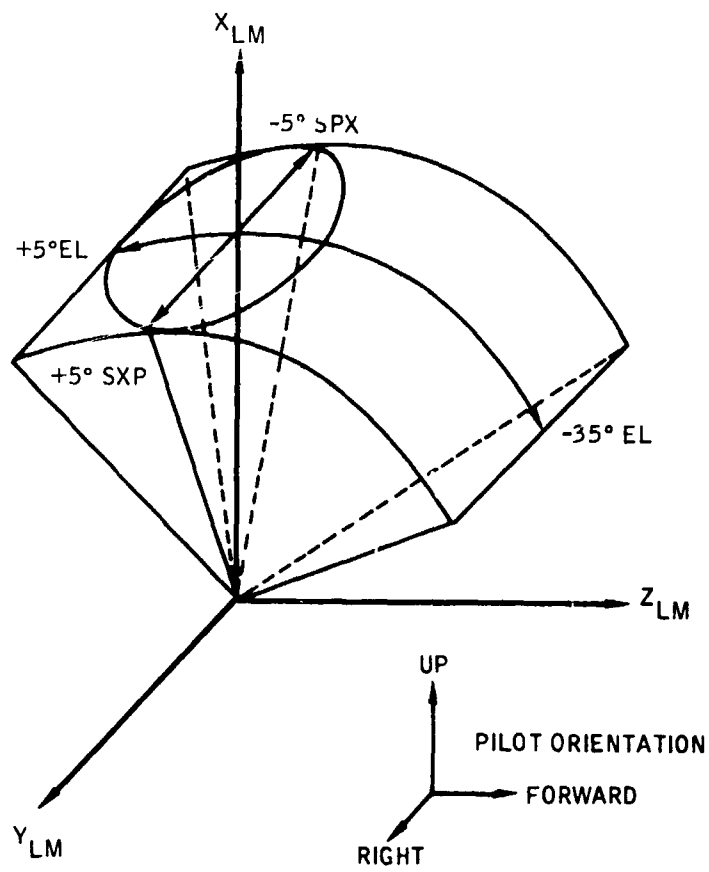

Figure 9.- LM COAS forward window mount (X-axis; target at infinite distance; taken from ref. 12).

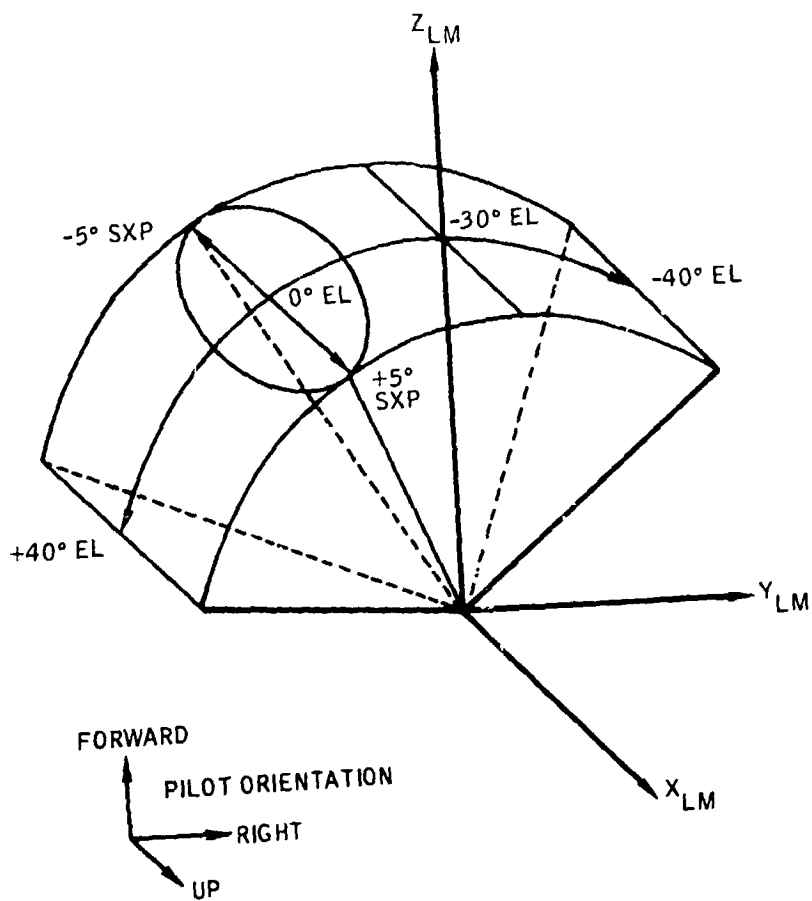

Figure 10.- LM COAS forward window mount (Z-axis; target at infinite distance; taken from ref. 12).

REFERENCES

1. Blucker, T. J.: Apollo Onboard Navigation System Constraints. MSC IN No. 67-FM-120, August 18, 1967.
2. MIT: Guidance System Operations Plan for SUNDISK. R-547, December 1967.
3. MIT: Guidance System Operations Plan for COLOSSUS. R-577, December, 1967.
4. LeBlanc, Curtis; and Manry, Charles: Apollo Optics Constraints. Presentation at MSC, June, 1967.
5. MIT: Guidance System Operations Plan for SUNDANCE. R-577, November, 1967.
6. Grumman: Universal Mission Module Data Book. LED-500-19, October 15, 1967.
7. Blucker, T. J.: Error Model for Apollo Onboard Navigation System. MSC Memo 66-FM42-107, April 7, 1966.
8. Blucker, T. J.: LEM Rendezvous Radar Coverage. MSC Memo 66-FM42-181, June 29, 1966.
9. Savely, R. T.: Onboard Navigation Comments. MSC Memo 68-FM47-85, March 8, 1968.
10. Blucker, T. J.: Onboard Time Line for AS-258. MSC Memo 67-FM42-56, March 28, 1967.
11. Blucker, T. J.: Verification of the RTCC Optics Computations for AS-205/CSM-101. MSC IN No. 67-FM-162, October 30, 1967.
12. Blucker, T. J.: Verification of the RTCC LM Optics Computations for First Manned LM Mission. MSC IN No. 67-FM-163, November 9, 1967.
13. NAA: Block II Optical Field-of-View Installed, Effectivity and Specifications Interface Control Document. MH01-01315-116.