

~~CONFIDENTIAL~~

CLASSIFICATION CHANGE

To UNCLASSIFIED
By authority CDS Gp4
Changed Leonid Stepanov Date 12/2/74
Classified at Master Control Station, NASA
Scientific and Technical Information Facility

Grumman Design 378B

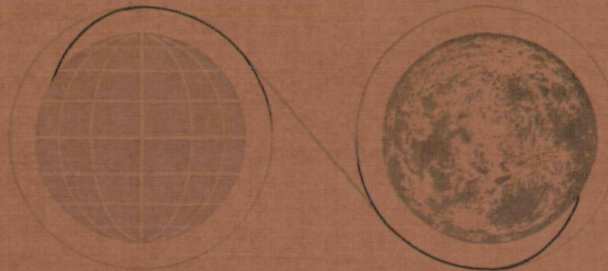

Apollo Extension Systems—Lunar Excursion Module
Phase B Final Report

FACILITY FORM 602	X 66 14549 (ACCESSION NUMBER)	_____
	<u>185</u> (PAGES)	(THRU) _____
	<u>CR-70904</u> (NASA CR OR TMX OR AD NUMBER)	<u>20</u> (CODE) _____
	_____	<u>3/</u> (CATEGORY) _____



Vol. X Shelter Master End Item Specification (U)

(NASA-CR-70904) APOLLO EXTENSION SYSTEMS: N75-75470
LUNAR EXCURSION MODULE. VOLUME 10: SHELTER
MASTER END ITEM SPECIFICATION Final Report
(Grumman Aircraft Engineering Corp.) 185 p

Unclas
00/98 27931

~~U. S. Government Agencies and Contractors Only~~

~~CONFIDENTIAL~~

~~CONFIDENTIAL~~

666-00084
Copy No. 11

~~U.S. Government and
Contractors~~

Apollo Extension Systems – Lunar Excursion Module Phase B Final Report

to

National Aeronautics and Space Administration
Manned Spacecraft Center
Advanced Spacecraft Technology Division
Houston, Texas 77058

by

Grumman Aircraft Engineering Corporation
Bethpage, New York

~~This document contains information affecting the national defense of the United States within the meaning of the Espionage Laws, Title 18, U.S.C., Sections 793 and 794, the transmission or revelation of which in any manner to an unauthorized person is prohibited by law.~~

~~Group 4 Document
Downgraded at 2 Year Intervals
Declassified after 12 Years~~

Vol. X Shelter Master End Item Specification



Contract No. NAS 9-4983
ASR 378B

8 December 1965

~~CONFIDENTIAL~~

Preface

This report presents the results of the Phase "B" Preliminary Definition Study (Contract NAS 9-4983) of the Lunar Excursion Module (LEM) and its modifications and additions, as necessary, for use in the Apollo Extension Systems (AES). This use includes a Laboratory for Earth and lunar orbital missions, and a Shelter, a Taxi and a Truck for extended-stay lunar surface missions. The overall objective of this study was to conduct sufficient analyses to provide a basis for selection by NASA of a single concept for each mission for final definition and development.

The study results are distributed in the volumes listed below in the following manner: Volume I contains a summary of the Preliminary Project Development Plan (PDP) with emphasis on estimates of the program costs and schedules. This volume was submitted on 30 October 1965, one month in advance of the remaining final documentation. Volume II is a brief summary of the overall study. Volumes III through XVI contain the design analyses, preliminary specifications, and operations analyses for each of the AES/LEM vehicle types. Volumes XVII through XXVI contain preliminary project planning data in the areas of management, manufacturing, development testing, and support.

It was necessary to base the preliminary project planning data, including estimated costs, on a single configuration for each of the AES/LEM vehicle types. Since these PDP data were required by the end of October, the configurations had to be selected at the mid-point of the study, before the configuration studies had been completed. These configurations have been called "baseline" configurations. The continuing design analyses in the second half of the study have resulted in recommended changes to the baseline configurations. Volumes III through VI describe the "recommended" configurations, the baseline configurations, and some additional alternates which were studied. It is anticipated that NASA will make a selection from these configurations, and that these selections will then be the new baseline configurations for the next phase of AES definition studies.

The scope of this study included integration of the experimental payloads with the Shelter and Taxi, but did not include study of the inte-

gration on individual LEM Laboratory flights. At approximately the mid-point of the study, an addendum was written with the objective of providing support to the NASA Mission Planning Task Force for study of the Phase I Laboratory flights. The schedule for the addendum calls for completion of these mission planning studies in January, 1966. Therefore, the addendum efforts are not described in this report.

The volumes which comprise this report are as follows:

- I *Phase B Preliminary Definition Plan (30 Oct 1965)*
- II *Preliminary Definition Studies Summary*
- III *Phase I Laboratory Design Analysis Summary*
- IV *Phase II Laboratory Design Analysis Summary*
- V *Shelter Design Analysis Summary*
- VI *Taxi Design Analysis Summary*
- VII *Truck Design Analysis Summary*
- VIII *Phase I Laboratory Master End Item Specification*
- IX *Phase II Laboratory Master End Item Specification*
- X *Shelter Master End Item Specification*
- XI *Taxi Master End Item Specification*
- XII *Phase I Laboratory Experimental Payload Performance & Interface Specification*
- XIII *Phase II Laboratory Experimental Payload Performance & Interface Specification*
- XIV *Shelter Experimental Payload Performance & Interface Specification*
- XV *Taxi Experimental Payload Performance & Interface Specification*
- XVI *Prelaunch & Mission Operations*
- XVII *Manufacturing Plan*
- XVIII *AES Modifications to LEM Quality Control Program Plan*
- XIX *Ground Development Test Plan*
- XX *Support Equipment Specification*
- XXI *Facilities Plan*
- XXII *Support Plan*
- XXIII *Transportation Plan*
- XXIV *Training Equipment Requirements*
- XXV *Support Equipment Requirements*
- XXVI *Management Plan*

~~CONFIDENTIAL~~

GRUMMAN AIRCRAFT ENGINEERING CORPORATION

Bethpage, L. I., N. Y.
Code 26512



SPECIFICATION

Page 1 of 180

Specification No. ESP 13-0100

Revision No. _____

Release Date 12-1-65

MASTER END ITEM SPECIFICATION

SHELTER

APOLLO EXTENSION SYSTEMS - LUNAR EXCURSION MODULE

Approved by: T. J. Barman
Project Engineer

Approved by: _____
(NASA Office)

Date: 12/1/65

Approval Date _____

This document contains information affecting the national defense of the United States, within the meaning of the Espionage Laws, Title 18, Sections 793 and 794, the transmission or revelation of which in any manner to an unauthorized person is prohibited by law.

Contract No. NAS 9-4983

Exhibit A; para. 6.1.7 Document Type Preliminary Line Item Primary No. _____

~~CONFIDENTIAL~~

GRUMMAN AIRCRAFT ENGINEERING CORPORATION

Bethpage, L. I., N. Y.
CODE IDENT 26512SPECIFICATION NO. ESP 13-0100TABLE OF CONTENTS

		<u>Page</u>
1	SCOPE	2
	1.1 Scope	2
2	APPLICABLE DOCUMENTS	2
	2.1 Document Precedence	2
	2.1.1 Specifications	2
	2.1.2 Standards	5
	2.1.3 Drawings	5
	2.1.4 Bulletins	5
	2.1.5 Other Publications	6
	2.2 Availability of Documents	6
	2.2.1 NASA and Government Documents	6
	2.2.2 Grumman Documents	6
	2.2.3 North American Aviation Corporation, Space and Information Systems Division Documents	6
3	REQUIREMENTS	7
	3.1 Performance Requirements	7
	3.1.1 Operational Requirements	7
	3.1.1.1 Mission Related Requirements	7
	3.1.1.2 Vehicle Performance Requirements	8
	3.1.1.3 Mission Technique	16
	3.1.2 Operability Requirements	16
	3.1.2.1 Reliability	16
	3.1.2.2 Maintainability	16

SPECIFICATION NO. ESP 13-0100

TABLE OF CONTENTS (Continued)

	<u>Page</u>
3.1.2.3 Useful Life	17
3.1.2.4 Natural Environment	17
3.1.2.5 Transportability and Ground Handling	29
3.1.2.6 Human Performance	29
3.1.2.7 Safety	34
3.1.2.8 Induced Environment	38
3.2 Interface Requirements	45
3.2.1 CSM Interface	45
3.2.2 SLA Interface	45
3.2.3 ACE Interface	45
3.2.4 MSFN Interface	45
3.2.5 NASA Crew Equipment Interface	45
3.2.6 EP Interface	46
3.2.7 GN and C Interface	46
3.2.8 Launch Facilities Interface	46
3.2.8.1 MLT Interface	46
3.2.8.2 MSS Interface	46
3.3 Design and Construction	46
3.3.1 General Design Features	46
3.3.1.1 Configuration	46
3.3.1.2 Weight	46
3.3.2 Selection of Specifications and Standards	46
3.3.3 Materials, Parts and Processes	46
3.3.3.1 Soldering	48
3.3.3.2 Wiring	48
3.3.4 Standard and Commercial Parts	48
3.3.5 Moisture and Fungus Resistance	48
3.3.6 Corrosion of Metal Parts	48

SPECIFICATION NO.: ESP 13-0100

TABLE OF CONTENTS (Continued)

	<u>Page</u>
3.3.7 Interchangeability and Replaceability	48
3.3.8 Workmanship	48
3.3.9 Electromagnetic Interference	49
3.3.9.1 Vehicle Interference Control	49
3.3.9.2 Vehicle Equipment Interference Control	49
3.3.10 Identification and Marking	49
3.3.11 Storage	50
3.3.12 Structural Design Criteria	50
3.3.12.1 Margins of Safety	50
3.3.12.2 Limit Conditions	50
3.3.12.3 Primary Structure Design	50
3.3.12.4 Pressure Vessel Design	50
3.3.12.5 Effects of Transportation, Handling and Storage	51
3.3.12.6 Vibration Design Requirements	51
3.3.12.7 Factors of Safety	51
3.3.13 Thermal Design Criteria	53
3.3.14 Radiation Protection	53
3.3.15 Micrometeoroid Protection	53
3.3.15.1 Penetration Mechanics	53
3.3.16 Modification Criteria	53
3.4 Requirements of Sub-Areas	53
3.4.1 Structural Design Subsystem (SDS)	56
3.4.1.1 Performance Requirements	56
3.4.1.2 Design Requirements	57

SPECIFICATION NO. ESP 13-0100

TABLE OF CONTENTS (Continued)

	<u>Page</u>
3.4.2 Electrical Power Subsystem (EPS)	65
3.4.2.1 EPS Performance	65
3.4.2.2 Design Requirements	67
3.4.3 Guidance, Navigation and Control Subsystem (GNCS)	78
3.4.3.1 Primary Guidance, Navigation and Control Subsystem (PGNCS)	78
3.4.3.2 Stabilization and Control Subsystem (SCS)	89
3.4.4 Reaction Control and Propulsion Subsystem	94
3.4.4.1 Performance	94
3.4.4.2 Design Requirements	101
3.4.5 Communications Subsystem (CS)	104
3.4.5.1 Performance Requirements	104
3.4.5.2 Design Requirements	109
3.4.6 Instrumentation Subsystem	116
3.4.6.1 Performance Requirements	116
3.4.6.2 Instrumentation Subsystem Design Requirements	117
3.4.7 Environmental Control Subsystem (ECS)	120
3.4.7.1 Performance Requirements	120
3.4.7.2 Design Requirements	126

SPECIFICATION NO. ESP 13-0100

TABLE OF CONTENTS (Continued)

	<u>Page</u>
3.4.8 Crew Provisions Subsystem (CPS)	135
3.4.8.1 Crew Equipment Performance Requirements	135
3.4.8.2 Cabin Arrangement Design Requirements	137
3.4.9 Displays and Controls Subsystem (D&C)	142
3.4.9.1 Performance Requirements	142
3.4.9.2 Design Requirements	154
3.4.10 Explosive Devices Subsystem (EDS)	155
3.4.10.1 Performance Requirements	155
3.4.10.2 Design Requirements	156
4 QUALITY ASSURANCE PROVISIONS	161
4.1 Quality Program	161
4.1.1 Identification and Traceability	161
4.2 Reliability Program	161
4.3 Tests	161
4.3.1 Development Tests	161
4.3.1.1 Design Feasibility Tests	161
4.3.1.2 Design Verification Tests	161
4.3.2 Qualification Tests	163
4.3.2.1 Qualification Testing Requirements	163
4.3.2.2 Design Limit Tests	167
4.3.2.3 Endurance Tests	167
4.3.2.4 Post-Qualification Tests	167

GRUMMAN AIRCRAFT ENGINEERING CORPORATION

Bethpage, L. I., N. Y.
CODE IDENT 26512SPECIFICATION NO. ESP 13-0100TABLE OF CONTENTS (Continued)

	<u>Page</u>
4.3.3 Test at Higher Levels	167
4.3.4 Acceptance Test	168
4.3.4.1 Applicability	168
4.3.4.2 Program Design	168
4.3.4.3 Procedure	169
4.3.4.4 Environments	170
4.3.4.5 Acceptance Basis	170
4.3.4.6 Test Equipment	170
4.3.5 Formal Engineering Acceptance Test (FEAT)	171
4.3.6 Electromagnetic Interference Test	171
5 PREPARATION FOR DELIVERY	171
5.1 Preservation and Packaging	171
5.2 Packing	171
6 NOTES	171
10 APPENDIX	172

GRUMMAN AIRCRAFT ENGINEERING CORPORATION

Bethpage, L. I., N. Y.
CODE IDENT 26512SPECIFICATION NO. ESP 13-0100ILLUSTRATIONS

<u>Figure</u>		<u>Page</u>
1	The Solar Spectrum	20
2	Probability - Solar Particle Events	24
3	Normalized Model-Time Dependent Integral Spectrum	25
4	Variation of Lunar Surface Temperature During a Complete Lunation	27
5	Emergency Carbon Dioxide Limit	31
6	Noise Limits	32
7	Unprotected Ear Noise Tolerance Limit	33
8	Vibration Curve (Human Sensitivity to Vertical Vibrations)	35
9	Vehicle Design	47
10	Level I Functional Diagram for Shelter	54 & 55
11	Electrical Distribution System Block Diagram	71
12	Fuel Cell Step Load Change Capability	73
13	Fuel Cell Reactant Flow vs. Gross Power	75
14	Fuel Cell Heat Rejection Rate vs. Gross Power	76
15	Thrust VS Time	96
16	Vacuum Specific Impulse VS Electrical Pulse Width	97

GRUMMAN AIRCRAFT ENGINEERING CORPORATION

Bethpage, L. I., N. Y.
CODE IDENT 26512SPECIFICATION NO. ESP 13-0100ILLUSTRATIONS (Continued)

<u>Figure</u>		<u>Page</u>
17	Descent Propulsion Nominal Mission	100
18	RCS General Arrangement	102
19	Communications Subsystem Block Diagram	105
20	Shelter Communication Links	106
21	Environmental Control Subsystem (Schematic)	121
22	Inboard Profile DWG.	141

TABLES

<u>Table</u>		<u>Page</u>
I	Estimates of Metabolic Rate, Thermal Balance, and Water Requirements for Crew Members	36
II	ECS Thermal Design Criteria	124
III	Electronic Equipment Cold Plate Characteristics	132

SPECIFICATION NO. ESP 13-0100MASTER END ITEM SPECIFICATIONSHELTERAPOLLO EXTENSION SYSTEMS-LUNAR EXCURSION MODULE (U)

1 SCOPE

1.1 Scope. - This specification establishes the requirements for performance, design, test and qualification of the Baseline Apollo Extension Systems-Lunar Excursion Module Shelter hereinafter identified as the Shelter. The Shelter shall supply the expendables and living quarters for two men on a 14 day lunar exploration mission while performing their assigned tasks. The Shelter shall land unmanned on the lunar surface and shall remain there in a quiescent mode for up to three months.

Specific deviations from the basic Shelter configuration which are imposed by different mission requirements shall be defined by individual End Item Specifications, prepared as addenda to this Master End Item Specification.

2 APPLICABLE DOCUMENTS

2.1 Document Precedence. - The following documents, of exact issue shown, form a part of this specification to the extent specified herein. In the event of conflict between the documents referenced here and other detail content of Sections 3, 4, 5, and 10, the detail requirements of Section 3, 4, 5, and 10 shall be considered a superseding requirement.

2.1.1 Specifications. -

NASA

<u>Number</u>	<u>Title</u>	<u>Date</u>
MSFC-PROC-158A	Soldering of Electrical Connections (High Reliability), Procedure for	4-12-62

GRUMMAN AIRCRAFT ENGINEERING CORPORATION

Bethpage, L. I., N. Y.
CODE IDENT 26512SPECIFICATION NO. ESP 13-0100

2.1.1 (Continued)

<u>Name</u>	<u>Title</u>	<u>Date</u>
MSC-ASPO-S-5B	Manned Spacecraft Center (MSC) Apollo Spacecraft Project Office (ASPO) Soldering Spec- ification; and Supplement dated 5-18-65	2-10-64
<u>Military</u>		
MIL-E-6051C	Electrical-Electronic System Compatibility and Inter- ference Control Requirements for Aeronautical Weapon Systems, Associated Subsystems and Aircraft	6-17-60
MIL-P-7788A	Plate, Plastic, Lighting	2-15-61
MIL-P-26539	Propellant, Nitrogen Tetroxide	4-5-63
MIL-P-27402	Propellant, Hydrazine and Unsymmetrical Dimethyl- hydrazine (50% N ₂ H ₄ + 50% UDMH)	8-25-51
<u>Grumman</u>		
ESP 13-9110	Experimental Payload Perfor- mance and Interface Specifica- tion, Shelter, Apollo Extension Systems - Lunar Excursion Module	12-1-65

GRUMMAN AIRCRAFT ENGINEERING CORPORATION

Bethpage, L. I., N. Y.
CODE IDENT 26512SPECIFICATION NO. ESP 13-0100

2.1.1 (Continued)

<u>Name</u>	<u>Title</u>	<u>Date</u>
LSP-14-001	Identification Markings, General Specification for	12-1-63
LSP-14-009 with Amendments 1 through 4	Preservation, Packaging and Packing, General Specification for	4-22-65
LSP-370-2A	Navigation and Guidance Subsystem, Rendezvous Radar/ Transponder and Landing Radar Sections, Design Con- trol Specification for	11-4-63
LSP-390-001	Bonding, Electrical, General Specification for	4-22-65
LSP-390-002	Wiring and Wiring Devices, Installation of, General Specification for	2-24-66
LSP-470-1A	Contract Technical Specifica- tion (U) Lunar Excursion Module System	6-7-65
LSP-530-001 with Amendment 1	Electromagnetic Interference Control Requirements, General Specification for	9-16-63

North American Aviation

TBD	AES-CSM/Shelter Performance and Interface Specification - Block II
-----	---

GRUMMAN AIRCRAFT ENGINEERING CORPORATION

Bethpage, L. I., N. Y.
CODE IDENT 26512SPECIFICATION NO. ESP 13-01002.1.2 Standards. -

<u>Number</u>	<u>Title</u>	<u>Date</u>
MIL-STD-704	Electrical Power, Aircraft, Characteristics and Utiliza- tion of	10-5-59
MIL-STD-810	Environmental Test Methods for Aerospace and Ground Equipment	6-14-62
<u>IRIG</u>		
IRIG-106-60	Inter-Range Instrumentation Group (IRIG) Standards	8-62

2.1.3 Drawings. -NASA

MSFC-10M01071	Manned Space Flight Center Drawing
---------------	---------------------------------------

Grumman

TBD	Level I Functional Diagram
-----	----------------------------

2.1.4 Bulletins. -NASA

AFMTCP-80-2 Vol. 1	General Spacecraft Center (MSC) Engineering Criteria Bulletin	11-8-63
-----------------------	---	---------

GRUMMAN AIRCRAFT ENGINEERING CORPORATION

Bethpage, L. I., N. Y.
CODE IDENT 26512

SPECIFICATION NO. ESP 13-0100

2.1.4 (Continued)

<u>Name</u>	<u>Title</u>	<u>Date</u>
EC-1	Manned Spacecraft Center (MSC) Engineering Criteria Bulletin	11-8-63

2.1.5 Other Publications. -

NASA

NPC-200-2	Quality Program Provisions for Space Systems Contractors	4-20-62
-----------	---	---------

NPC-250-1	Reliability Program Provisions for Space Systems Contractors	7-63
-----------	---	------

2.2 Availability of Documents. -

2.2.1 NASA and Government Documents. - Copies of NASA and Government documents may be obtained from the Superintendent of Documents, Government Printing Office, Washington, D.C., 20402.

2.2.2 Grumman Documents. - Copies of this specification and other applicable Grumman documents may be obtained from AES Program Data Management, Grumman Engineering Corporation, Bethpage, Long Island, New York, 11714.

2.2.3 North American Aviation Corporation, Space and Information Systems Division Documents. - Copies of North American Aviation Corporation, Space and Information Systems documents may be obtained from NAA, SID, Downey, California, Attention: Mr. R. Berry, Mgr. Assoc. Contr. Admin.

SPECIFICATION NO. ESP 13-0100

3 REQUIREMENTS

3.1 Performance Requirements. -3.1.1 Operational Requirements. -3.1.1.1 Mission Related Requirements. -

- (a) The Shelter shall be capable of accomplishing an unmanned landing on the lunar surface from an 80 nmi lunar orbit and landing at preselected sites on the near-Earth-side of the lunar surface with a Circular Error Probability (CEP) of TBD nmi. (Actual landing sites for combined Shelter/Taxi operations will be restricted by Taxi ascent rendezvous requirements).
- (b) The Shelter shall survive unmanned lunar surface storage of up to 3 months and perform satisfactorily thereafter for up to 14 days of manned operation during any phase of the lunar day-night cycle.
- (c) The Shelter shall be capable of delivering up to TBD pounds of payload to the lunar surface. Such payload will survive the lunar storage period and operate independently of the Shelter.
- (d) During manned operations on the lunar surface, the Shelter shall provide life support, environmental protection and living accommodations for a crew of two, as specified herein. The Shelter shall provide for ingress/egress to the lunar surface for EVA, and EVA expendables support, to the limits specified herein.
- (e) The Shelter shall provide for communications with earth, the CSM and EVA's during mission phases as specified herein. The Shelter shall also provide location aids for Taxi landing.

GRUMMAN AIRCRAFT ENGINEERING CORPORATION

Bethpage, L. I., N. Y.
CODE IDENT 26512

SPECIFICATION NO. ESP 13-0100

3.1.1.2 Vehicle Performance Requirements. -

3.1.1.2.1 Guidance Navigation and Control Requirements. - The Shelter shall be capable of:

- (a) Automatically landing unmanned at a preselected lunar site. Vertical velocity at touchdown shall not exceed TBD + TBD ft/sec. and horizontal velocity shall not exceed TBD + TBD ft/sec. The Shelter shall be oriented to within TBD degrees of the lunar local vertical at touchdown.
- (b) Accepting and maintaining a reference coordinate system for guidance computations established by an astronaut, while the Shelter is attached to the CSM in lunar orbit.
- (c) Determining and accepting initial conditions and updated information for the guidance problem.
- (d) Computing (based on accelerometer, radar and stellar measurements, etc.) and commanding the steering and thrust commands required to effect the orbital changes and descent trajectory for the Shelter mission.
- (e) Establishing the mission operations sequence logic.
- (f) Automatically pointing the S-Band steerable antenna and acquiring and maintaining earth tracking for telecommunications.

3.1.1.2.2 Propulsion Requirement. - The Shelter shall be capable of:

- (a) Providing thrust magnitude and control. The thrust shall be variable (----to----) to provide an efficient descent trajectory and velocity control during the approach to the landing area, hover and touchdown.
- (b) Providing thrust misalignment and cg offset compensation (+ 6.0 degrees, pitch & roll).
- (c) Providing start and stop capabilities.

GRUMMAN AIRCRAFT ENGINEERING CORPORATION

Bethpage, L. I., N. Y.
CODE IDENT 26512

SPECIFICATION NO. ESP 13-0100

3.1.1.2.2 (Continued)

- (d) Providing propellant and pressurization storage capability on the basis of maximum ΔV weight requirements.
- (e) Providing a propellant management capability to control cg offsets.
- (f) Generate display and instrument parameters.

3.1.1.2.3 Reaction Control Requirements. - The Shelter shall:

- (a) Provide capability for producing angular moments of TBD ft lbs about its X axis, TBD ft lbs about the y and z axes simultaneously.
- (b) Provide TBD ft/sec² acceleration in the positive X axis.
- (c) Provide pressurization and propellant storage capability consistent with the effective delta-velocity requirements.

3.1.1.2.4 Electrical Power Requirements. - The Shelter shall be capable of:

- (a) Supplying its own electrical power during lunar descent, unmanned storage and manned operation up to TBD kwh total.
- (b) Supplying electrical power to experiments for operation on the Shelter on the lunar surface up to TBD kwh total.
- (c) Supplying electrical power for battery recharge of the crewmen's Portable Life Support Systems (PLSS) up to TBD watt-hr total.
- (d) Having its Electrical Power Subsystem (EPS) activation remotely controlled by earth command.

3.1.1.2.5 Environmental Control Requirement. - The Shelter shall be capable of:

GRUMMAN AIRCRAFT ENGINEERING CORPORATION

Bethpage, L. I., N. Y.
CODE IDENT 26512

SPECIFICATION NO. ESP 13-0100

3.1.1.2.5 (Continued)

- (a) Maintaining nominal cabin pressure of 5 psia during pressurized cabin operation by supplying oxygen at a rate equal to cabin leakage plus crew consumption.
 - (1) The capability shall be provided to maintain a cabin pressure of at least 3.5 psia for two minutes following puncture of the pressure shell by an equivalent 1/2-inch diameter hole, with the cabin initially at 5 psia.
 - (2) Provisions shall be made for a cabin leak rate of 0.2 lb/hr plus reserve oxygen supply equivalent to an additional leak rate of TBD lb/hr.
- (b) Depressurizing the Shelter cabin within TBD min., TBD min. for emergencies, and repressurization to 3.7 psia within TBD min.
- (c) Supplying oxygen for TBD repressurizations of the cabin following partial or complete cabin decompressions.
- (d) Maintaining cabin environmental control during pressurized operations and space suit environmental control during unpressurized ventilation; removing of odors and noxious gases; removing of foreign objects which might cause ECS malfunction or impairment of crew performance; removing of moisture; and controlling the carbon dioxide level in the atmosphere.
- (e) Cooling or heating the suit circuit from TBD to TBD degrees F.
- (f) Cooling or heating the cabin atmosphere from TBD to TBD degrees F.
- (g) Active thermal control of all Shelter equipment which is not passively cooled, during landing and manned surface operations.
- (h) Rejecting the Shelter waste heat.

SPECIFICATION NO. ESP 13-0100

3.1.1.2.5 (Continued)

- (i) Active thermal control of Shelter equipment which cannot survive ambient conditions during lunar storage.
- (j) Preventing overpressurization of the pressure shell.
- (k) Providing a water management system for distribution of all drinking, food preparation and cooling water required for the Shelter mission and for recharge of the PLSS after EVA.

3.1.1.2.6 Telecommunications Requirements. - The Shelter shall provide for:

- (a) Communications with the Manned Space Flight Net (MSFN) to 220,000 nmi slant range minimum for the several mission phases as follows:
 - (1) Lunar orbit checkout:
 - a. Two-way voice
 - b. Telemetry
 - c. Emergency key
 - d. Tracking and ranging aids
 - e. Earth command reception
 - (2) Lunar descent:
 - a. Telemetry
 - b. Tracking and ranging aids
 - c. Earth command reception

SPECIFICATION NO. ESP 13-0100

3.1.1.2.6 (Continued)

(a) (Continued)

(3) Lunar storage and Taxi flight:

- a. Telemetry
- b. Earth command reception

(4) Lunar manned operations:

- a. Two-way voice
- b. Telemetry (including biomed)
- c. Emergency key
- d. EVA biomed and voice relay to Earth
- e. Earth command reception

(b) Communications with the CSM while docked and to 550 n. mi. slant range minimum when separated for the several mission phases as follows:

(1) Lunar orbit checkout:

- a. Two-way voice
- b. Telemetry

(2) Lunar descent:

Telemetry until earth acquisition of Shelter

SPECIFICATION NO. ESP 13-0100

3.1.1.2.6 (Continued)

(b) (Continued)

(3) Lunar storage and Taxi flight:

None required

(4) Manned surface operations:

Two-way voice

(c) Communications with an extra-vehicular crewman during lunar surface operations (EVA):

(1) Two-way voice

(2) Receive biomed telemetry for relay

(d) Communications with the Taxi during Taxi descent:

(1) Tracking and ranging aid for landing

(e) Operational instrumentation to acquire and process data determining spacecraft and crew status, route data for transmission for ground monitoring and to the crewmen for caution and warning display during manned operations. Operational instrumentation shall be fully in operation during Shelter orbit, checkout and descent; during the period immediately preceding and during the Taxi flight (7 days total time); and during manned lunar surface operations. Operational instrumentation shall be normally OFF but shall be operative upon earth command at any time during the unmanned storage period (up to 87 days).

(f) Limited experiment support by using excess operational instrumentation capability to handle preconditioned experiment data. The Shelter will provide no signal conditioning for experiment data.

GRUMMAN AIRCRAFT ENGINEERING CORPORATION

Bethpage, L. I., N. Y.
CODE IDENT 26512

SPECIFICATION NO. ESP 13-0100

3.1.1.2.7 Structural Requirements. -

- (a) Thermal Control - The Shelter shall be protected thermally from the environmental extremes which occur when attached to the CSM during translunar coast and lunar orbits, and during lunar landing, storage and manned operations.
- (b) Meteoroid Protection - Meteoroid protection shall be provided to prevent critical damage of equipment or expendables and possible loss of crew.
- (c) Crew Visibility - Exterior visibility provisions for the Shelter crew are to be determined. Interior visibility shall not be blocked by projecting structure.
- (d) Ingress/Egress - Means shall be provided to allow the crew to pass to and from the CM while the vehicles are joined, and to and from the lunar surface after Taxi landing.
- (e) Pressurized Cabin - The cabin shall be capable of holding oxygen at 5.2 psia pressure. The cabin shall also be capable of experiencing multiple repressurization cycles.
- (f) Support for Equipment (Subsystems and Experiments) - The primary structure and secondary equipment supporting structure shall sustain, without failure, the loads imposed by accelerations and vibrations originating from the launch vehicle and SM engine, and the loads produced during docking and lunar landing. When required, the structure shall provide an interface with the equipment that minimizes shock and vibration inputs, and holds the required alignments between dependent pieces of equipment and between equipment and vehicle body axes.

SPECIFICATION NO. ESP 13-0100

3.1.1.2.7 (Continued)

- (g) Shelter/CSM Docking Interface - The docking interface with the CSM shall permit a structural tie between the vehicles to allow intra-vehicular transfer of crew for Shelter checkout and preparation procedures. The interface with the CSM should be at the Shelter upper tunnel and in a plane perpendicular to the X axis.

3.1.1.2.8 Crew Provisions Requirements. - Provisions shall be made for the following:

- (a) Space Suit Assembly and Portable Life Support System - Capability for crew members to don spacesuit assemblies unaided within TBD minutes, and to perform required tasks while suited up and on the suit loop of the ECS. Capability to don PLSS and maneuver for EVA ingress/egress.
- (b) Lighting - Internal and external illumination necessary to perform the tasks required during lunar orbit checkout and manned lunar surface operations.
- (c) Living Necessities - Food, water, waste management, working and sleeping accommodations, recreation and personal hygiene for a crew of two for up to 14 days.
- (d) Inboard Configuration Control - Selection, allocation and arrangement of space for stored or installed items and expendables for crew utilization within the pressurized cabin area. The arrangement and accessibility of controls, displays, and equipment shall allow the crew to efficiently accomplish necessary tasks, including ingress/egress.

SPECIFICATION NO. ESP 13-0100

3.1.1.3 Mission Technique. - The relationship between the mission phases delineated in 3.1.2.8 and the detail mission profile shall be defined in the individual end item specifications written as addenda to this specification for each flight.

3.1.2 Operability Requirements. -

3.1.2.1 Reliability. - The mission success reliability objectives for the Shelter shall be based on the operating times and environmental conditions incurred during each Shelter flight.

3.1.2.1.1 Reliability Objectives. - The reliability objectives for the Shelter shall be:

(a) Mission Success: TBD

(b) Crew Safety: TBD

The reliability objectives shall be exclusive of radiation and meteoroid impact consideration.

3.1.2.1.2 Crew Safety Reliability Objective. - The crew safety reliability objective shall be to minimize the probability of injury or loss of a crew member, due to a failure, or combination of failures, of Shelter equipment.

3.1.2.2 Maintainability. - Where feasible, the Shelter shall be designed to provide accessibility, replaceability and serviceability consistent with efficient servicing, checkout and maintenance operations. As a design consideration Shelter equipment shall be designed for rapid repair or replacement of malfunctioned equipment consistent with launch window requirements. Where practical, maintenance of Shelter equipment shall not require the use of special tools.

3.1.2.2.1 Vehicle Maintenance Concept. - There shall be no in-flight maintenance requirement for subsystems except for certain items which will be identified by Grumman and approved by NASA. The Shelter subsystems shall be designed for field maintenance as follows:

SPECIFICATION NO. ESP 13-0100

3.1.2.2.1 (Continued)

- (a) For electrical or electronic equipment or both (either installed or on the bench), checkout and replacement shall be at the integral package (black box) level. A "black box" is defined as a combination of factory replaceable units which are contained within a physical package, and which is removable from the Shelter as an integral unit.
- (b) For non-electrical or non-electronic equipment or both (either installed or on the bench) checkout and replacement shall be at the lowest replaceable serialized unit level, which includes only those parts which are removable as integral units from the Shelter.

3.1.2.2.1.1 Test Points. - Test points and test ports shall be provided and identified to permit rapid fault isolation to the replaceable assembly or component, as applicable.

3.1.2.3 Useful Life. - The Shelter subsystems equipment shall be designed for an operating life and shelf life consistent with the operational and reliability requirements. Storage of explosive materials is a special case covered in the explosive device subsystem.

3.1.2.4 Natural Environment. - The Shelter shall be designed to meet its operational requirements during and after exposure to the following natural environments:

3.1.2.4.1 Transportation, Ground Handling and Storage of Non-Operating Shelter Equipment. - The following environments will be encountered by non-operating Shelter equipment during transportation, ground handling and storage. Shelter equipment shall be protected by suitable packaging for transportation and storage if these environmental extremes exceed the equipment design requirements.

3.1.2.4.1.1 Temperature. -

(a) Ground Transportation:

- (1) Packaged: -65 to +160 degrees F for two weeks

SPECIFICATION NO. ESP 13-0100

3.1.2.4.1.1 (Continued)

(a) (Continued)

(2) Unpackaged: -20 to +110 degrees F air temperature plus 360 BTU/sq ft/hr up to six hours per day.

(b) Air Transportation: -45 to +140 degrees F for eight hours

3.1.2.4.1.2 Sand and Dust. - As simulated by MIL-STD-810, Method 510, Procedure I. Modify exposure temperature to +90 \pm 20 degrees F instead of +160 degrees F.

3.1.2.4.1.3 Fungi. - Exposure as defined in MIL-STD-810, Method 508, Procedure I.

3.1.2.4.1.4 Ozone. - Three years exposure at 0.05 PPM concentration.

3.1.2.4.1.5 Salt Spray. - As simulated by Method 509 of MIL-STD-810, Procedure I.

3.1.2.4.1.6 Humidity. - Exposure as defined in MIL-STD-810, Method 507, Procedure I. Modify maximum temperature portion of cycle from +160 degrees F to +110 degrees F.

3.1.2.4.1.7 Rain. - Exposure as defined in MIL-STD-810, Method 506. (No direct impingement on flight hardware).

3.1.2.4.1.8 Pressure. -

(a) Air Transportation: Minimum of 3.45 psia for 8 hours (35,000 feet altitude).

(b) Ground Transportation and Storage: Minimum of 11.78 pounds per square inch absolute (psia).

3.1.2.4.2 Earth Ascent, Earth Orbit, Translunar Injection, Translunar Coast, Lunar Orbit Insertion, Lunar Orbit and Lunar Descent. -

3.1.2.4.2.1 Pressure. - Atmospheric pressure at sea level to less than 10^{-13} mm Hg.

SPECIFICATION NO. ESP 13-0100

3.1.2.4.2.2 Thermal Radiation. - The source of radiation presented below impinges on the exterior of the Shelter in logical combination:

- | | |
|--|-----------------------------|
| (a) Solar Flux: | 442 BTU/ft ² /hr |
| (b) Earth Emission: | 73 BTU/ft ² /hr |
| (c) Lunar Emission
(sub-solar point): | 419 BTU/ft ² /hr |
| (d) Lunar Emission
(dark side): | 2.2 BTU/ft ² /hr |
| (e) Earth Albedo
(over entire solar spectrum): | 0.35 |
| (f) Earth Albedo
(over visible spectrum): | 0.40 |
| (g) Lunar Normal Albedo
(over entire solar spectrum): | 0.047 |
| (h) Lunar Normal Albedo
(over visible spectrum): | 0.098 |
| (i) Lunar Spherical Albedo
(over visible spectrum): | 0.073 |
| (j) Space Sink Temperature: | 4 degrees K |

NOTES: 1. Thermal emitted energy distribution to be interpreted according to cosine law.

2. Electromagnetic radiation from the sun is shown in Figure 1.

3.1.2.4.2.3 Meteoroid Environment. - The meteoroid environment is defined in MSC Engineering Criteria Bulletin, EC-1, for sporadic and shower meteoroids.

X-RAYS ULTRAVIOLET OPTICAL INFRARED RADIO

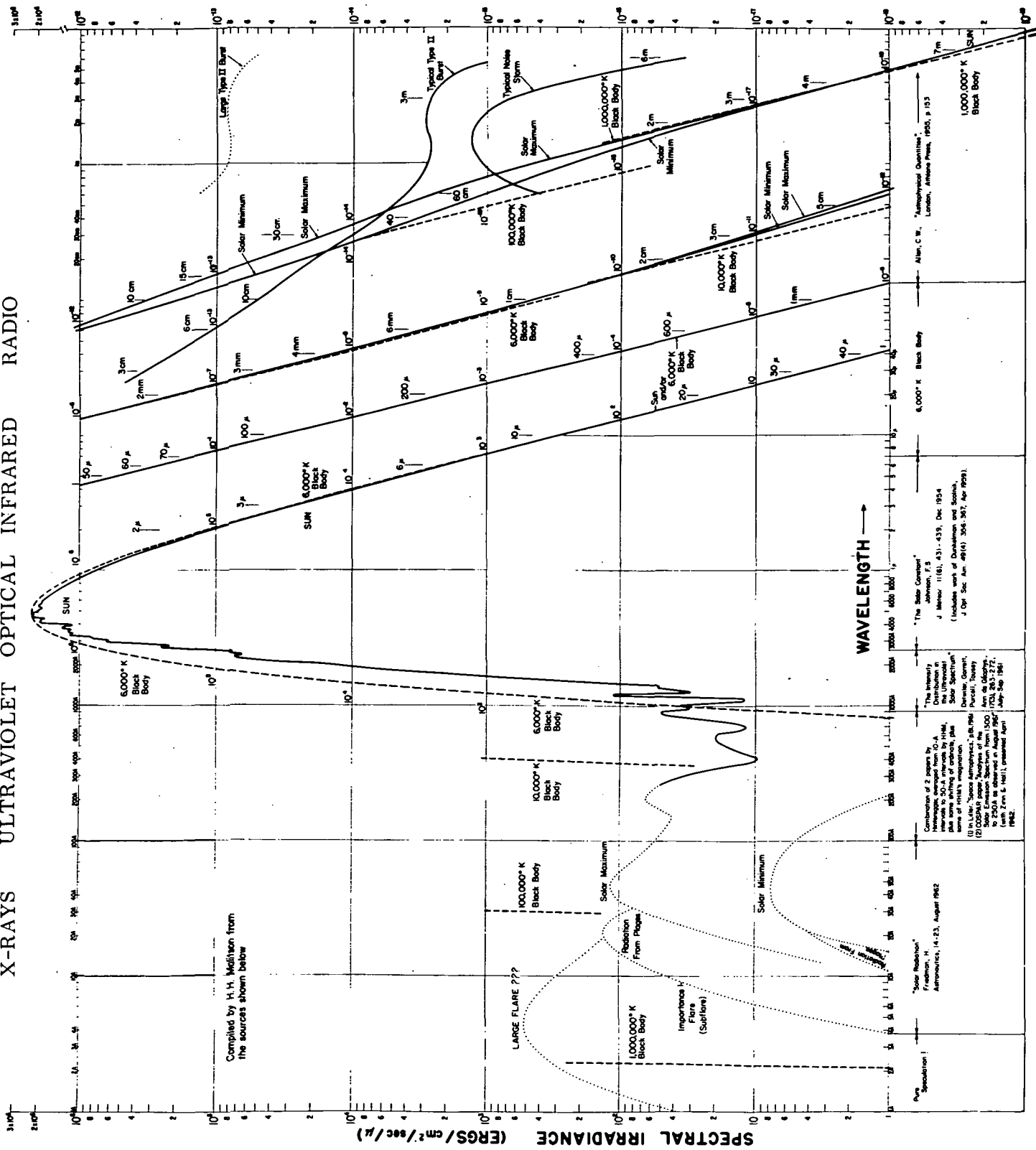

Compiled by H.H. Madison from the sources shown below

"The Solar Constant"
J. Minnow (1918), 431-439, Dec. 1914
(Includes work of Delebo and Svanberg,
J. Opt. Soc. Am. 49(1) 304-307, Apr 1929)

"The Intensity Distribution in the Solar Spectrum"
Dewar, Garnett, Purcell, Townley
Proc. Roy. Soc. London, Ser. A, 130, 283-272,
July-Sep 1931

Combination of 2 papers by
Hemphill, Scoville from O.A.
Hemphill, Scoville, and Townley,
plus some shifting of curves, plus
some of Hillel's imagination.
(Hillel, "Space Temperature", J. Opt. Soc. Am. 19, 100-104, 1924)
(O.A. Hemphill, "Space Temperature", J. Opt. Soc. Am. 19, 100-104, 1924)
to 250A as observed in August 1957
(with Zern E. Hall), presented April 1962.

"Solar Radiation"
Fradin, H.
Astronomical Journal, 64-23, August 1962

Fig. 1 The Solar Spectrum

SPECIFICATION NO. ESP 13-0100

3.1.2.4.2.4 Nuclear Radiation. - The nuclear radiation environments for near-earth, cislunar and near-lunar space will be as presented below:

- (a) Trapped Radiation - Radiation levels due to the Van Allen and artificial belts will use protons and electrons fluxes obtained from the Goddard Orbital Flux Code.
- (b) Galactic Cosmic Rays - Galactic cosmic ray doses range from 0.1 radiation absorbed dosage (RAD) per week for solar activity maximum to 0.3 RAD per week for solar activity minimum.
- (c) Solar Particle Events - The solar particle events described below are for rigidities above the cut-off rigidity for solar particle events in the earth's magnetic field. The cut-off rigidity is defined by:

$$N = \frac{2.49 \times 10^9}{(6371 + h)^2} \left[\frac{2 + \cos^3 \lambda - 2(1 + 3 \cos^3 \lambda)^{1/2}}{\cos^2 \lambda} \right]$$

where:

N = Particle's cut-off rigidity, BV.

h = Altitude, KM.

λ = Geomagnetic latitude.

NOTE: Solar particle events will be considered to contain solar produced alphas and protons with equal rigidity spectra.

- (1) Time-Integrated Spectra - The time-integrated spectrum for alphas and protons with rigidities greater than 137 MV (10 Mev) will be considered to be of the form:

$$N(> P) = N_0 \text{ EXP } \left[-P/P_0 \right] \text{ where } P=137 \text{ MV.}$$

where:

$N(> P)$ = time integrated flux with rigidities greater than P, particles/cm².

SPECIFICATION NO. ESP 13-0100

3.1.2.4.2.4 (Continued)

(c) (1) (Continued)

N_0 = total intensity of event, particles/cm².

P = particle rigidity, million volts.

P_0 = characteristics rigidity, million volts.

The rigidity of a particle is given by:

$$P = \frac{-1}{Z_e} (T^2 + 2 T M_0 C^2)^{1/2}$$

where:

Z_e = particle's charge in units of electron charge e, i.e.,

$Z_e = -1$ (for protons) and $Z_e = -2$ (for alphas).

T = particle kinetic energy, Mev.

$M_0 C^2$ = particle's rest mass energy, Mev

$M_0 C^2 = 938.2$ Mev for protons:

$M_0 C^2 = 3727.1$ for alphas.

P_0 is evaluated in the energy ranges:

$10 \text{ Mev} \leq T \leq 30 \text{ Mev}$ and $30 \text{ Mev} \leq T \leq 100 \text{ Mev}$.

Below 10 Mev the spectrum is defined by:

$$N(> T) = N_0 T^{-n}$$

A model spectrum is described by the following expressions:

$$T < 10 \text{ Mev}: N(> T) = 22.3 N(> 239 \text{ MV}) T^{-1.2}$$

$$137 \text{ MV} \leq P < 239 \text{ MV}: N(> P) = 35.5 N(> 239 \text{ MV}) e^{-P/67}$$

$$P \geq 239 \text{ MV}: N(> P) = 10.9 N(> 239 \text{ MV}) e^{-P/100}$$

SPECIFICATION NO. ESP 13-0100

3.1.2.4.2.4 (Continued)

(c) (1) (Continued)

where: $N(> 239 \text{ MV})$ is the number of particles/cm² with rigidities greater than 239 MV (30 Mev) encountered during the mission. Figure 2 shows the probability of encountering greater than $N(> 239 \text{ MV})$. Particles/cm² during the mission plotted against $N(> 239 \text{ MV})$. The values obtained for N_0 shall be considered to hold for both alphas and protons.

- (2) Time Dependent Spectrum - The model time dependent integral spectrum is shown in Figure 3 for several rigidities. The spectrum will be considered to hold for both alphas and protons. Note that the spectrum is normalized to one particle/cm² with rigidities greater than 0.239 B_v for the entire event.

3.1.2.4.3 Lunar Surface Environment. -

3.1.2.4.3.1 Meteoroid Environment. - The meteoroid environment is defined in MSC Engineering Criteria Bulletin, EC-1 for sporadic, shower and secondary meteoroids. The density for secondary meteoroids will be 2.5 g/cc instead of 3.5 g/cc as delineated in MSC Engineering Criteria Bulletin, EC-1.

3.1.2.4.3.2 Radiation Environment. - The radiation environment is the same as that contained in 3.1.2.4.2.4 with an appropriate shielding factor for the moon.

3.1.2.4.3.3 Lunar Thermal Model. -

3.1.2.4.3.3.1 Surface Temperatures. - The variation of the surface temperature of a point on the lunar equator during a complete lunation (29.53 days) is shown by a solid line in Figure 4. During the lunar day, the temperatures of local surface areas may be up to 30 degrees centigrade higher than the averaged temperatures shown on this plot. This

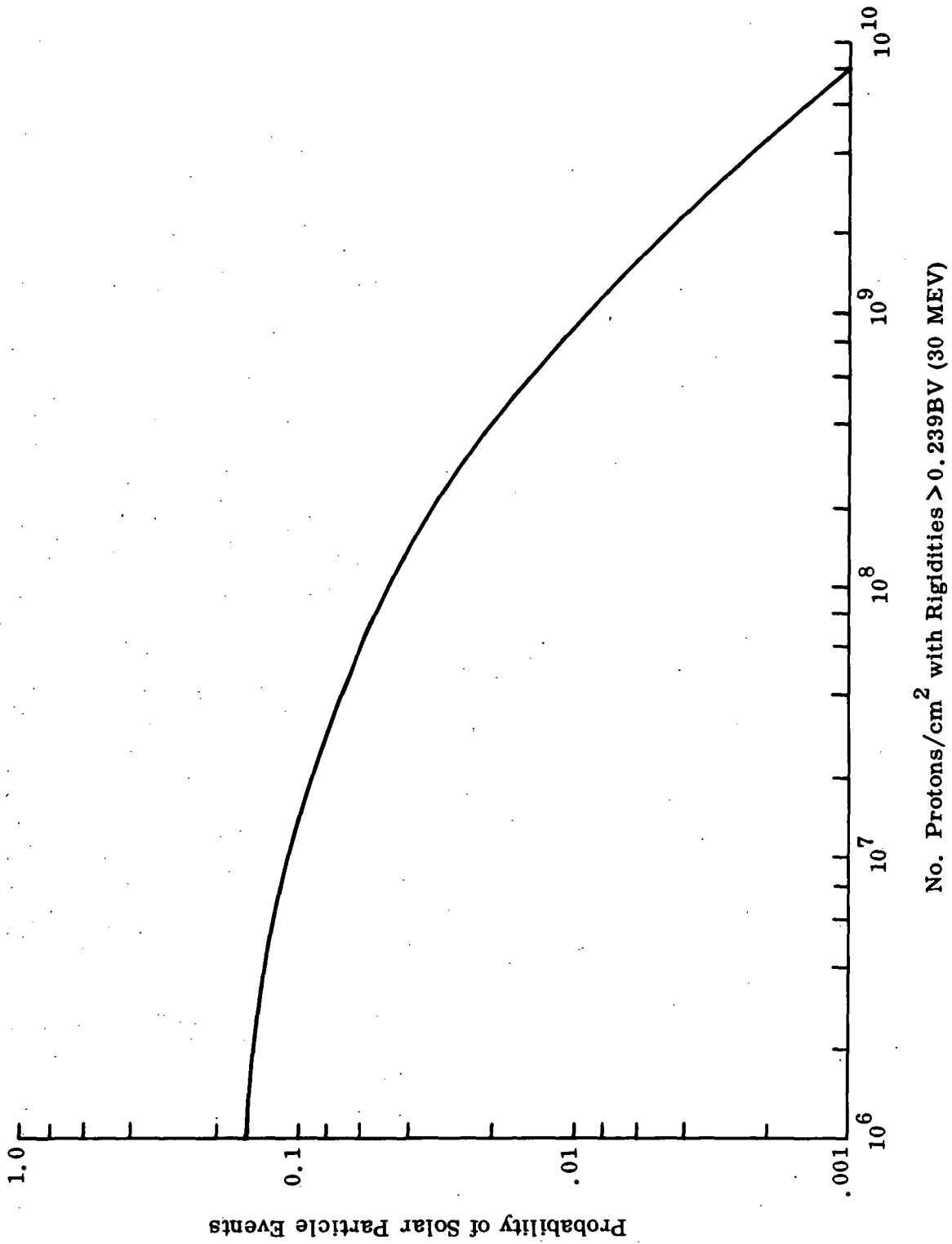

Fig. 2 Probability - Solar Particle Events

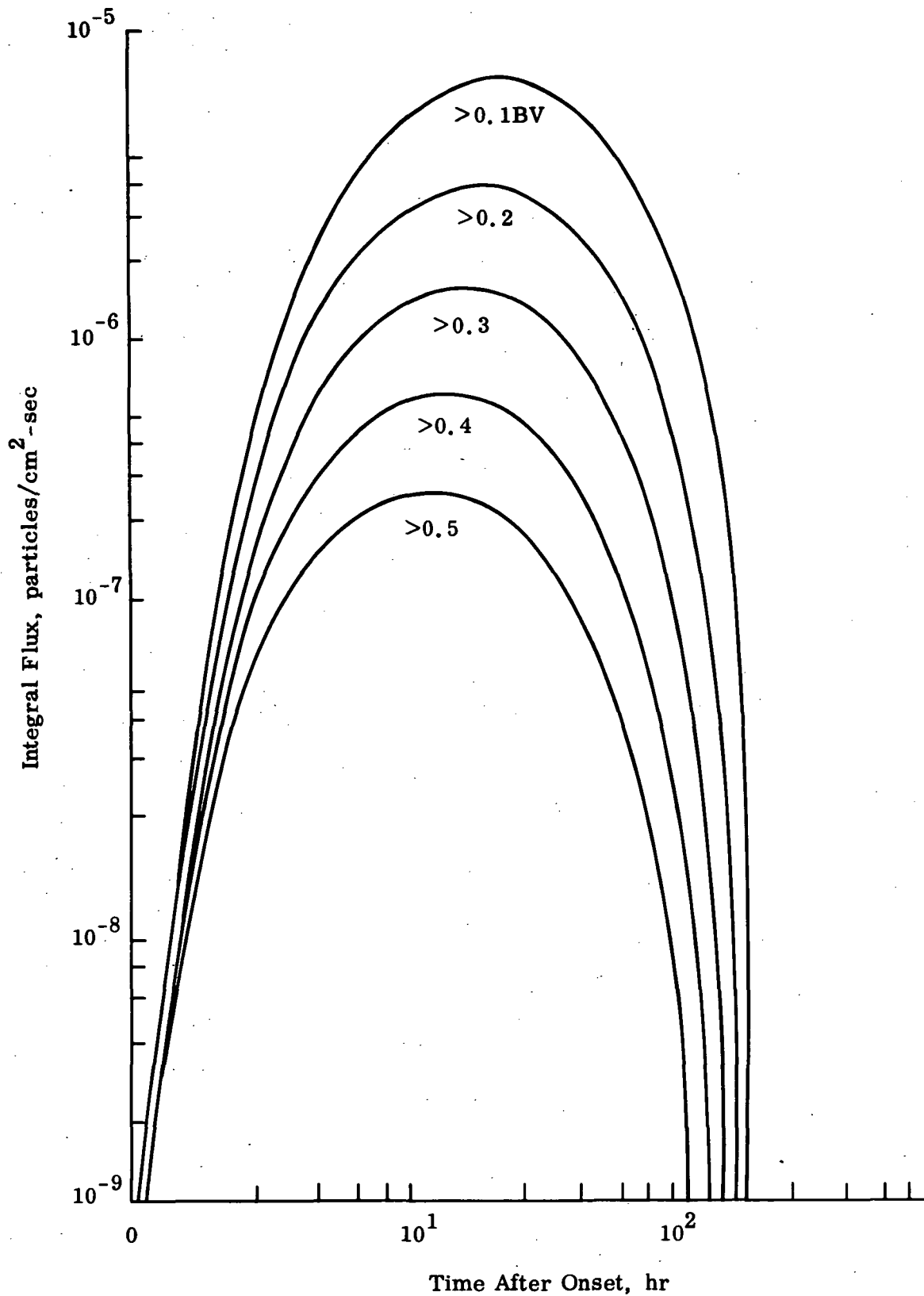

Fig. 3 Normalized Model - Time Dependent Intergral Spectrum

Grumman

SPECIFICATION NO. ESP 13-0100

3.1.2.4.3.3.1 (Continued)

effect is due to local variations in albedo and topography, which cannot be taken into consideration on such a plot. For a point at some higher latitude, the temperature decreases approximately as the cosine of the latitude to the 1/4 power, as compared to the temperature of an equatorial point at the same brightness longitude. The characteristics of a normal terrestrial rock is shown in Figure 4 by a dash line, ($\gamma=30$).

3.1.2.4.3.3.2 Thermal Properties. -

3.1.2.4.3.3.2.1 Average Model. - The variation of the lunar surface temperature during a lunar day is shown in Figure 4. The measured surface temperatures are best fit by a theoretical survey of temperature versus time based on a lunar surface thermal inertia $\gamma \approx 750$ (cgs units). The thermal inertia $\gamma = (k\rho c)^{-1/2}$.

where:

- (a) K (thermal conductivity) $\approx 1.0 \times 10^{-5}$ cal/cm/sec/degree centigrade.
- (b) ρ (density) ≈ 0.9 gm/cm³.
- (c) c (specific heat) ≈ 0.2 cal/gm/degrees centigrade.

3.1.2.4.3.3.2.2 Model for Local Variation. - Although most, if not all, of the lunar surface is covered with material having the above properties, there may be local patches of material whose thermal properties approach those of normal terrestrial rocks (Figure 4). Such material would have approximately the following characteristics:

- (a) k $\approx 2.2 \times 10^{-3}$ cal/cm/sec/degrees centigrade.
- (b) $\rho \approx 2.5$ gm/cm³.
- (c) c ≈ 0.2 cal/gm/degrees centigrade.
- (d) $\gamma = (k\rho c)^{-1/2} \approx 30$ cgs units.

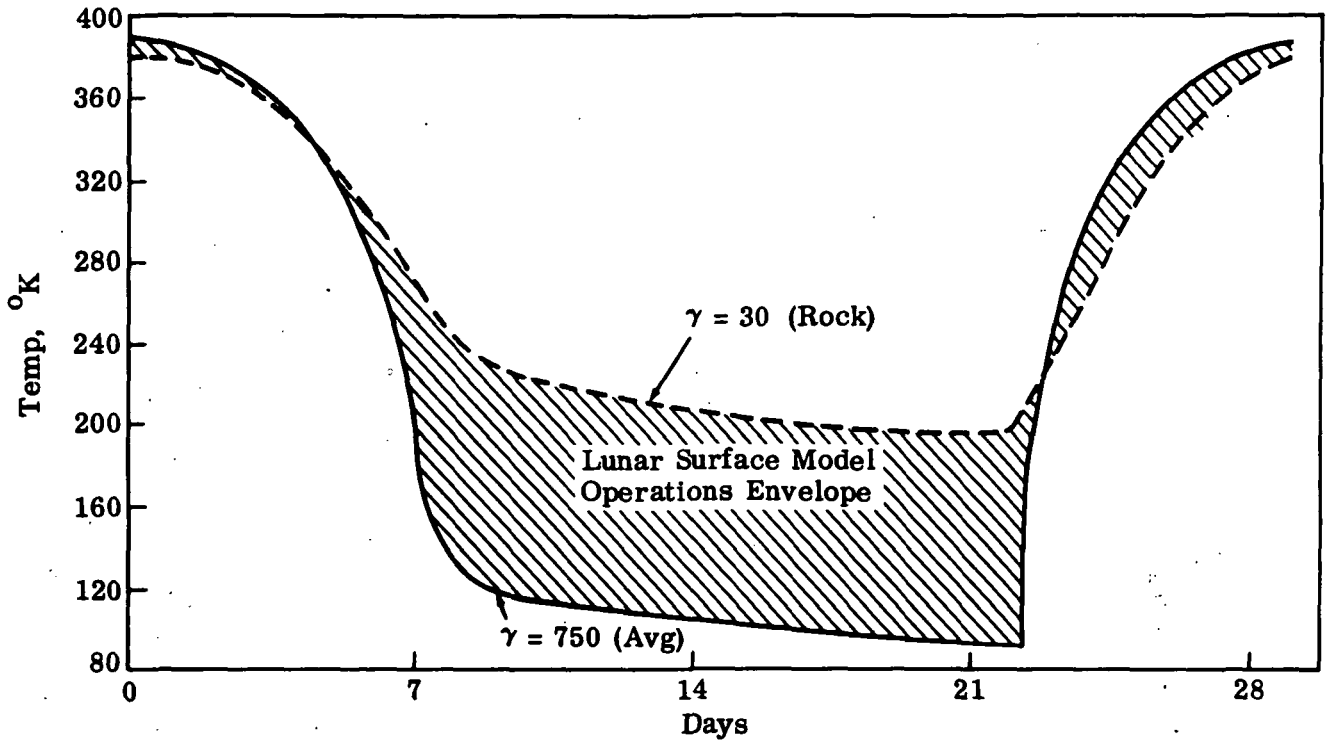

Fig. 4 Variation of Lunar Surface Temperature During a Complete Lunation

SPECIFICATION NO. ESP 13-0100

3.1.2.4.3.4 Lunar Model at Touchdown Point. - The following is a description of a lunar touchdown point solely for the purposes of Shelter design:

- (a) The touchdown point at the landing site is considered to be a circle having a radius of 10 meters. The landing site is considered to be an area of about 10 square kilometers.
- (b) The surface consists both of high porosity material (either a cohesive or noncohesive aggregate) of variable thickness and a structurally competent material. A combination of these materials, whose essential properties are described in (c) and (d), may produce a heterogeneous surface which does not exceed the requirements listed in (a) through (g).
- (c) The minimum bearing strength of the high porosity material is such that a static load of 7×10^4 dynes/cm² (1 lb/in²) will penetrate no more than 10 cm (4 in) and a dynamic load of 8.3×10^5 dynes/cm² (12 lb/in²) will penetrate no more than 60 cm (24 in) below the surface.
- (d) The effective rigidity and strength of the structurally competent material is infinite.
- (e) Shallow depressions and low protuberances will be sufficiently numerous so that one or more of the landing pads of the Shelter will be horizontally constrained after moving along the surface a variable distance. The coefficient of friction that may be expected during horizontal sliding will vary between 0.4 and 1.0. Topography in the touchdown area will produce both forms of surface resistance.
- (f) The "effective protuberances" at the touchdown point will be less than 60 cm (24 in.). Effective protuberances may result from single protuberances such as blocks, or from various combinations of heights, depressions, and surface sinkage within a horizontal distance of approximately 10 meters (11 yards).

SPECIFICATION NO. ESP 13-0100

3.1.2.4.3.4 (Continued)

- (g) The "effective slopes" at the touchdown point will not exceed 12 degrees. The effective slope consists of the general surface slope of the touchdown area plus or minus the combined effects of protuberances, depressions and surface sinkage. The increment of the "effective slope" due to protuberances and depressions (after accounting for erosion and soils mechanics effects) may be calculated from the formula:

$$\text{Arc sin } \left[\frac{\text{Height of protuberance} + \text{depth of depression}}{2 (\text{overturn radius of the landing gear})} \right]$$

3.1.2.5 Transportability and Ground Handling. - Full design recognition shall be given to the durability requirements of Shelter equipment during transportation preparation. Wherever possible, equipment shall be designed to be transported by a common carrier. The use of protective materials and devices to insure no damage to the equipment shall be minimized. Special packaging and transportation methods shall be employed as required to prevent damage to the equipment.

3.1.2.6 Human Performance. - The vehicle design shall utilize the capability of the crew to perform efficiently throughout the mission. The design shall reflect human engineering principles. Provisions for preferred presentation arrangements, ease of maintenance, environmental and personnel safety shall be considered for ground and flight personnel.

3.1.2.6.1 Visibility. - The required external visibility will be achieved with a minimum amount of glass. Parallax, distortions, and unwanted reflection from glass (both window and instrument cover) and similar surfaces shall be kept to a minimum. Anti-reflection coatings on glass surfaces shall be used in order to reduce reflection. Consideration shall be given to the use of variable density optical filters for windows in order to reduce light from sun shafting and earth and lunar reflections. When not in use, these filters shall be retractable from the window area. Internal lighting shall provide for control and display panel illumination. It shall be adjustable in intensity to compensate for varying ambient light conditions and also to insure retention of crew visual adaptation.

SPECIFICATION NO. ESP 13-0100

3.1.2.6.2 Atmospheric Environments. - The crew shall be provided a cabin atmosphere with the following characteristics for nominal operations:

- (a) Pressure: 5.0 ± 0.2 psia
- (b) Oxygen Partial Pressure: 233 mm Hg
- (c) Carbon Dioxide Partial Pressure: 7.6 mm Hg
- (d) Temperature: 75 ± 5 degrees Fahrenheit
- (e) Relative Humidity: 40 percent to 70 percent

For emergency conditions, the following limits apply:

- (f) Pressure: 3.7 ± 0.2 psia
- (g) Oxygen Partial Pressure: 160 mm Hg absolute
- (h) Carbon Dioxide Partial Pressure: See Figure 5
- (i) Temperature: 120 degrees Fahrenheit for four hours
maximum

Nominal limits are defined as the limits within which the crew's environment shall be maintained during extended and normal operations. Emergency limits are defined as the environmental limits beyond which there is an increased probability of degraded performance or irreversible injury.

3.1.2.6.3 Noise Limits. - The noise non-stressed limits to the crew's ear canals shall not be greater than that shown in Figure 6, including an average at 55 db in the 600 CPS to 4800 CPS range to a reference level of 0.002 dynes/cm². The stressed limit is that noise level where combinations of white noise duration and decibel level measured at the entrance of the crewman's ear canal shall not be greater than that defined by Figure 7. A limiting constraint shall be that the maximum noise level permissible is that which will permit communications with the ground and between crew members at all times and

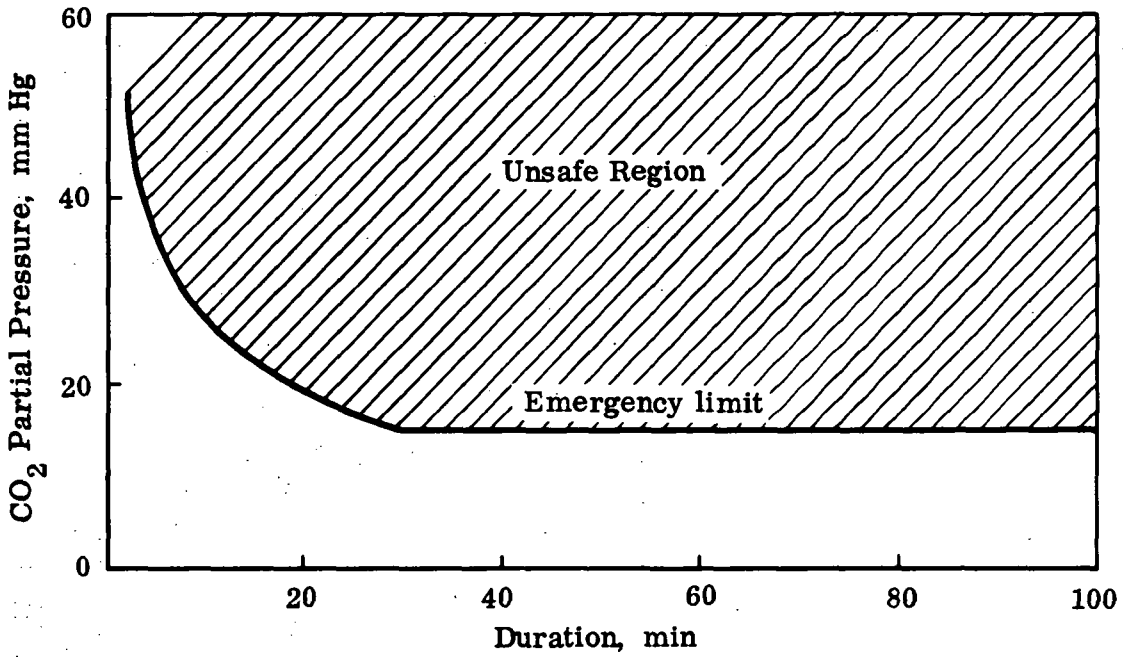

Fig. 5 Emergency Carbon Dioxide Limit

Grumman

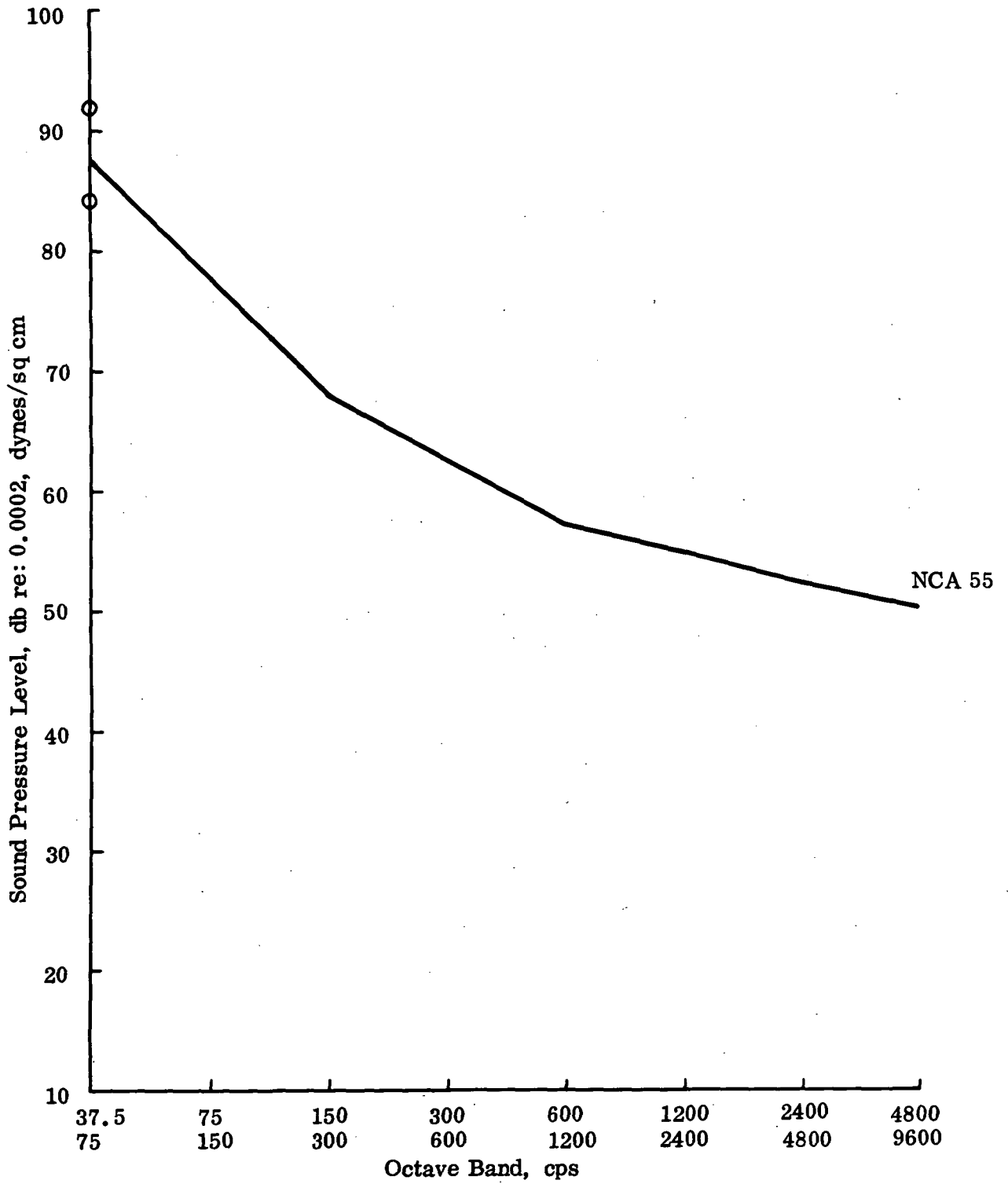

Fig. 6 Noise Limits

SPECIFICATION NO. ESP 13-0100

3.1.2.6.3 (Continued)

which will not induce physiological disturbances. The emergency limit shall be considered that limit at which the crew finds the noise painful or tissue damage can occur. For design and test purposes, 127 db or higher peak value sustained for a period of no more than 2.5 seconds, in a pattern of equal periods of rest or low noise relief, is defined as the emergency limit. Pure tones generated in the cabin by operating equipment will be kept to a minimum intensity level.

3.1.2.6.4 Crew Vibration Limits. - The stress limits are those vibration loads which are uncomfortable to the crew but tolerable below the painful threshold, and shall not be greater than defined in Figure 8. The emergency limit shall be considered that limit at which the crew finds the vibration painful or where tissue damage can occur. The emergency limit shall not be greater than depicted in Figure 8 for less than one minute; one minute; and three minutes. For continuous exposure the continuous maximum tolerable curve shall be used. Crew performance degradation will occur immediately during emergency stress. Exposure to nominal stressed limits will result in performance degradation if sufficient recovery time is not provided between vibratory pulses. Minimum recovery time is equal to twice the exposure time period.

3.1.2.6.5 Metabolic Requirements. - Metabolic requirements and rates for various mission phase activities shall be as shown in Table I.

3.1.2.7 Safety. -

3.1.2.7.1 Hazard Proofing. - The design of Shelter shall minimize the hazard of fire, explosion and toxicity to crew. Launch area personnel and facilities shall also be considered in designing for hazard proofing. Toxic, combustible and corrosive materials accumulated from leakages, and discharges from equipment sources or static potentials capable of ignition shall not occur.

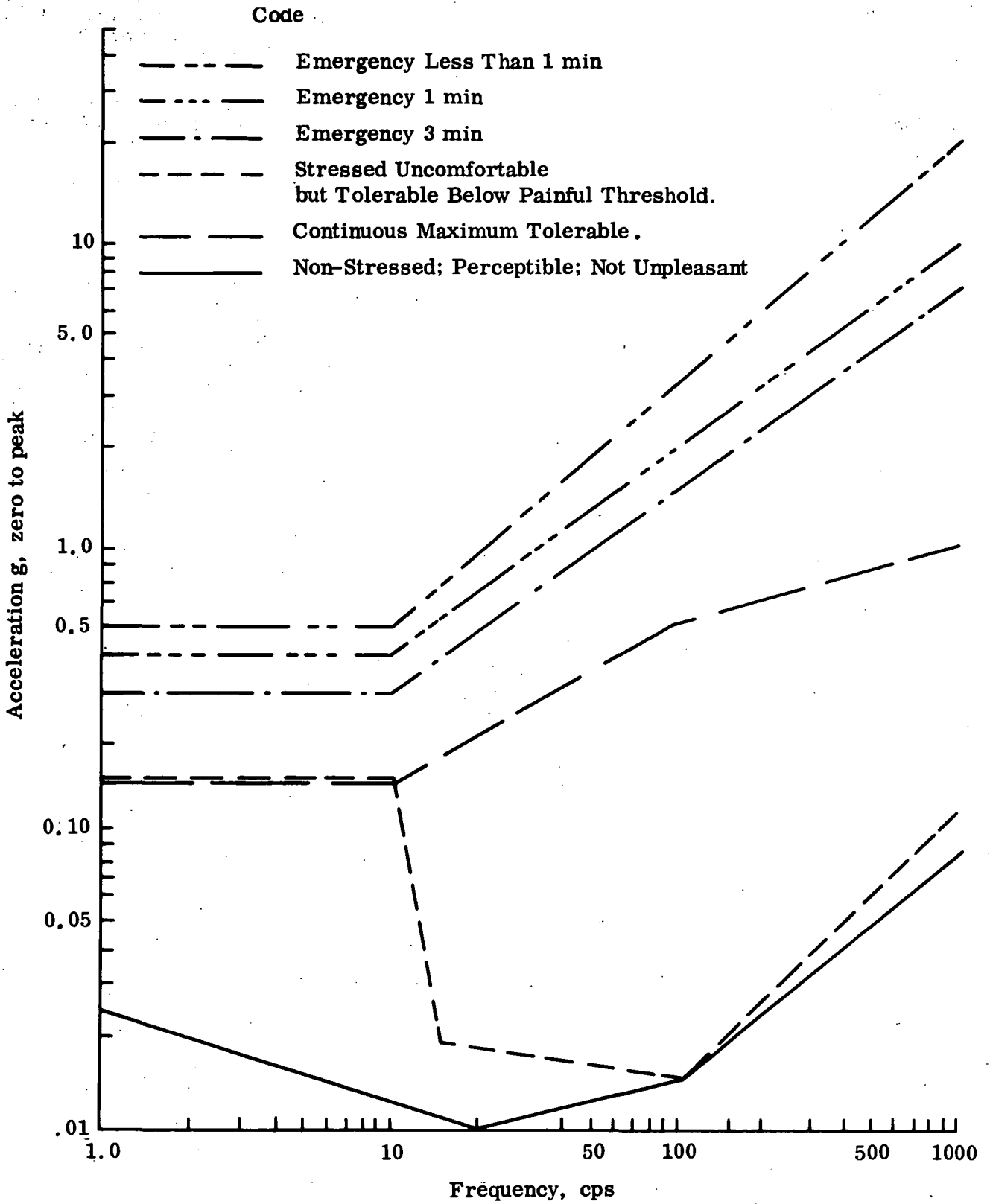

Fig. 8 Vibration Curve (Human Sensitivity to Vertical Vibrations)

Grunman

SPECIFICATION NO. ESP 13-0100

TABLE I
ESTIMATES OF METABOLIC RATE,
THERMAL BALANCE AND WATER
REQUIREMENTS FOR CREW MEMBERS

	<u>PER MAN</u>	<u>UNIT OF MEASURE</u>	<u>ROUTINE FLIGHT</u>		<u>EMERGENCY DECOMPRESSION</u>	<u>LUNAR SURFACE EXTRAVEHICULAR OPERATIONS</u>
			<u>PER HOUR</u>	<u>PER DAY</u>	<u>PER HOUR</u>	<u>PER HOUR</u>
(a)	Heat Output	BTU				
(b)	Oxygen	lbs				
(c)	Carbon Dioxide	lbs				
(d)	Latent Heat (lungs)	BTU				
(e)	Latent Heat (sweat)	BTU		TBD		
(f)	Sensible Heat	BTU				
(g)	Urinary Loss	g				
(h)	Sweat Loss	g				
(i)	Lung Loss	g				
(j)	Total Water Requirement	g				
(k)	Total Water Requirement	lbs				
(l)	Food Consumption	K cal				

SPECIFICATION NO. ESP 13-0100

3.1.2.7.2 Explosion Proofing. - Shelter components shall be either hermetically sealed or of explosion proof construction.

3.1.2.7.3 Fail Safe. - A failure in a subsystem or component shall not cause a failure in any other subsystem or component; that is, the design shall be "fail safe".

3.1.2.7.4 Shelter and Personnel Safety Requirements. - The design shall consider the following Shelter and personnel safety requirements:

- (a) Toxicological control of outgas in Shelter atmosphere.
- (b) Cabin control of aerosols, dust (such as LiOH from LiOH cartridges) and condensates.
- (c) The Shelter interior and exterior shall be free of sharp objects, metal burrs or any abrasive surface which may puncture or otherwise damage the space suit or harm the crew.
- (d) The cabin shall have adequate hand holds to facilitate controlled movement under zero "g" and interior design free of "traps" whereby a crewman wearing a pressurized suit may become jammed or wedged and be incapable of escape.
- (e) Eye protection from direct (unfiltered) sunlight.
- (f) Bacteriological and fungus control.
- (g) Provisions for securing items stowed or transferred into the Shelter cabin, to prevent their becoming a cabin hazard during vehicle operation.
- (h) Protection from electrical shock hazard.
- (i) Protection from cryogenic lines (freezing).
- (j) Protection from static electrical hazard.

SPECIFICATION NO. ESP 13-0100

3.1.2.7.4 (Continued)

- (k) Explosion proofing.
- (l) Shielding from space thermal radiation hazard.
- (m) Protection from excessive radiative heat loss.
- (n) Protection from microwave and other RF radiation.
- (o) Prevention of excessive load lifting (strain) and excessive fatigue.
- (p) Protection for a suited crewman from damaging the suit by proper design and use of scientific instruments, stowage, packaging, and specimen containers.
- (q) "Non Slip" Shelter walking surfaces.
- (r) Fail safe and "jam proof" umbilical connections.
- (s) Connectors keyed to preclude mismatching.
- (t) Provisions for safe egress/ingress to the vehicle, such as hand holds, ladder, etc.

3.1.2.7.4.1 Crew Safety Design Criteria. - The Shelter shall be designed such that no single failure shall cause the loss of all methods of implementing a function critical to crew safety. In those instances where redundant control and information paths are provided for crew safety, the redundant mechanical and electrical elements of these paths shall be separated from each other where practicable.

3.1.2.8 Induced Environment. - The Shelter shall be designed to meet its operational requirements during and after exposure to the induced environments listed in the following paragraphs.

3.1.2.8.1 Prelaunch. -

3.1.2.8.1.1 Prelaunch - Packaged. - Transportation and handling in the shipping container shall not produce critical design loads on the

SPECIFICATION NO. ESP 13-0100

3.1.2.8.1.1 (Continued)

Shelter equipment and shall not increase the flight weight of the equipment. The equipment shall be protected by a suitable shipping container if the following externally induced environments caused by transportation and handling exceed the equipment design requirements.

- (a) Acceleration - 2.67g vertical with 0.4g lateral applied simultaneously to the package. This condition also applies to the complete Shelter.
- (b) Shock - In accordance with MIL-STD-810, Method 516, Procedure III.
- (c) Vibration - Sinusoidal vibration shall be applied to the test package along the three mutually perpendicular axes (X, Y, and Z). The frequency shall be cycled three times between 5 cps and maximum cps and back to 5 cps at an applied double amplitude or accelerations as detailed by weights in (1), (2) or (3). The rate of change of frequency shall be logarithmic at 1/2 octave per minute.

(1) For 100 pounds or less:

<u>cps</u>	<u>g or D.A.</u>
5-7.2	0.5 in D.A.
7.2-26	<u>±</u> 1.3g
26-52	.036 in D.A.
52-500	<u>±</u> 5.06g

- (2) For 100 pounds to 300 pounds: Use Figure 514.8, Method 514 of MIL-STD-810 for maximum frequency.

GRUMMAN AIRCRAFT ENGINEERING CORPORATION

Bethpage, L. I., N. Y.
CODE IDENT 26512

SPECIFICATION NO. ESP 13-0100

3.1.2.8.1.1 (Continued)

(c) (Continued)

(3) For 300 pounds or more:

<u>cps</u>	<u>g or D.A.</u>
5-7.2	0.5 in D.A.
7.2-26	$\pm 1.3g$
26-52	.036 in D.A.

(d) Electromagnetic Interference. - In accordance with 3.3.9.

3.1.2.8.1.2 Prelaunch - Unpackaged. - Ground handling equipment shall not produce critical design loads on the Shelter equipment and shall not increase its flight weight. The unpackaged equipment shall meet its operational requirements after exposure to the following ground handling externally induced environments.

- (a) Acceleration - 2.67g vertical with 0.4g lateral applied simultaneously. This condition also applies to the complete Shelter.
- (b) Shock - In accordance with MIL-STD-810, Method 516, Procedure I except, modify shock pulse to a sawtooth 15g peak, having a 10 to 12 millisecond rise and a 0-2 millisecond decay.
- (c) Pressure (Ambient Ground Level) - Hermetically sealed units installed in the crew compartment will be subjected to a maximum pressure of 20.5 psi absolute during preflight checkout.
- (d) Hazardous Gases - As simulated by MIL-STD-810, Method 511 and in accordance with MSFC Drawing 10M01071. This condition also applies to the complete Shelter.
- (e) Electromagnetic Interference - Same as prelaunch - packaged.

GRUMMAN AIRCRAFT ENGINEERING CORPORATION

Bethpage, L. I., N. Y.
CODE IDENT 26512

SPECIFICATION NO. ESP 13-0100

3.1.2.8.2 Launch and Boost. - (See NOTE 7)

(a) Acceleration (See NOTE 5):

	X		Y		Z	
	RAD	G	RAD	G	RAD	G
	SEC ²		SEC ²		SEC ²	
Lift Off Condition	+1.60	--	+ .65	--	+ .65	--
Max Q Condition	+2.07	--	+ .30	--	+ .30	--
End Boost Condition	+4.90	--	+ .10	--	+ .10	--
Engine Hardover	-1.70	--	+ .10	--	+ .10	--
Engine Hardover	+2.15	--	+ .40	--	0	--
Earth Orbit	+2.15	--	0	--	+ .40	--
	0	0	0	0	0	0

(b) Acoustics - As specified in North American Specification
TBD.

(c) Vibration (See NOTE 6) - The mission vibration environment is represented by the following random and sinusoidal envelopes considered separately:

(1) Exterior Primary Structure -

a. Random -

10 to 23 cps	12 db/octave rise to
23 to 80 cps	0.0148g ² /cps
80 to 105 cps	12 db/octave rise to
105 to 950 cps	0.044g ² /cps
950 to 1250 cps	12 db/octave decrease to
1250 to 2000 cps	0.0148g ² /cps

SPECIFICATION NO. ESP 13-0100

3.1.2.8.2 (Continued)

(c) (1) (Continued)

b. Sinusoidal -

5 to 18.5 cps 0.154 inches double amplitude

18.5 to 100 cps 2.69g peak

(2) Interior Primary Structure -

a. 10 to 23 cps 12 db/octave rise to

23 to 80 cps 0.0148g²/cps

80 to 100 cps 12 db/octave rise to

100 to 1000 cps 0.0355g²/cps

1000 to 1200 cps 12 db/octave decrease to

1200 to 2000 cps 0.0148g²/cps

b. Sinusoidal -

5 to 16 cps 0.154 inch double amplitude

16 to 100 cps 1.92g peak

During the launch and boost phase of flight the Shelter is exposed to random vibration of varied levels and spectra for 17 minutes. During all but approximately 2.5 minutes of this period, the intensity of the random vibration is of such a low level that it is considered to be of negligible design significance. In addition, the launch and boost environment is considered to include peak vibration levels which are represented by the above sinusoidal vibration envelopes.

GRUMMAN AIRCRAFT ENGINEERING CORPORATION

Bethpage, L. I., N. Y.
CODE IDENT 26512

SPECIFICATION NO. ESP 13-0100

3.1.2.8.2 (Continued)

(c) (2) b. (Continued)

The number of sinusoidal peaks for design can be considered to be one percent of the natural frequency of the equipment being designed times the number of seconds of exposure. For design purposes, the above random spectrum applied for 5 minutes along each of the three mutually perpendicular axes, X, Y and Z, when applied in addition to the above sinusoidal vibration for 300 seconds exposure time will adequately represent the vibration environment. Vibration levels may be lower at specific equipment locations due to the reaction of equipment on primary structure. Therefore, a rationally demonstrated reduction in these levels may be used for Shelter equipment design and test.

(d) Pressure - Atmospheric pressure at sea level to 1×10^{-8} mm Hg (N₂) as specified in North American Specification TBD.

(1) Controlled Cabin - 20.5 psia to 5.4 psia (O₂) with decay time of approximately 2 minutes.

(2) Uncontrolled Cabin - Decay to 1×10^{-4} mm Hg is approximately 17 minutes.

(e) Temperature - As specified in North American Specification TBD.

(f) Hazardous Gases - Same as prelaunch unpackaged.

(g) Electromagnetic Interference - Same as prelaunch unpackaged.

3.1.2.8.3 Space Flight-Translunar. -

(a) Acceleration - (See NOTE 5)

SPS operating:

SPS not operating:

(b) Shock - (See NOTE 5):

Condition transposition

X		Y		Z	
g	Rad/Sec ²	g	Rad/Sec ²	g	Rad/Sec ²
-.36	--	+.062	+1.99	+.062	+1.99
0	0	0	0	0	0
-.052	--	+.065	+1.10	+.065	+1.10

SPECIFICATION NO. ESP 13-0100

3.1.2.8.3 (Continued)

- (c) Vibration Service Propulsion System (SPS) Operating. - Present information indicates that the levels are of negligible design significance and need not be considered for design or test.
- (d) Plume Effects - As specified in North American Specification TBD.
- (e) Electromagnetic Interference - Same as prelaunch unpackaged.

- NOTES:
1. Factors of safety are not included in the levels specified in 3.1.2.8.1.1 through 3.1.2.8.3.
 2. All accelerations are "earth g's".
 3. Vibration spectra shown give straight lines on a log-log plot.
 4. Packaged and unpackaged - The word "packaged" refer to containers used for transportation, handling and storage.
 5. Acceleration and shock levels are at the Shelter center of gravity.
 6. For launch and boost vibration, the primary structure which is directly excited by the acoustics transmitted through the Spacecraft LEM Adapter (SLA) is designated exterior primary structure. The primary structure which either does not face the adapter or is shielded from it by another piece of structure is designated interior primary structure.
 7. The environments specified in 3.1.2.8.2 represent preliminary figures and will be modified after mass properties of the equipment installed on the Shelter are determined.

SPECIFICATION NO. ESP 13-0100

3.2 Interface Requirements. - The Shelter shall be compatible with and shall satisfy the requirements of the following interfaces:

- (a) Command Service Module, (CSM).
- (b) Spacecraft Lem Adapter, (SLA).
- (c) Acceptance Checkout Equipment, (ACE)
- (d) Manned Space Flight Net, (MSFN)
- (e) NASA Crew Equipment
- (f) Experimental Payload, (EP)
- (g) Guidance, Navigation and Control, (GFE - GN & C)
- (h) Mobile Launcher Tower, (MLT)
- (i) Mobile Service Structure (MSS)

3.2.1 CSM Interface. - The Shelter shall be compatible with the CSM interface requirements as specified in North American Aviation Performance and Interface Specification TBD.

3.2.2 SLA Interface. - The Shelter shall be compatible with the SLA interface requirements as specified in North American Aviation Performance and Interface Specification TBD.

3.2.3 ACE Interface. - The Shelter shall be compatible with the ACE interface requirements which will be determined.

3.2.4 MSFN Interface. - The Shelter shall be compatible with the MSFN interface requirements as specified in Grumman Specification TBD.

3.2.5 NASA Crew Equipment Interface. - The Shelter shall be compatible with the NASA Crew Equipment Interface requirements as specified in Grumman Specification TBD.

GRUMMAN AIRCRAFT ENGINEERING CORPORATION

Bethpage, L. I., N. Y.
CODE IDENT 26512

SPECIFICATION NO. ESP 13-0100

3.2.6 EP Interface. - The Shelter shall be compatible with the EP interface requirements as specified in ESP 13-9110.

3.2.7 GN and C Interface. - The Shelter shall be compatible with the GFE section of the GN & C as defined by Grumman Specification TBD.

3.2.8 Launch Facility Interface. -

3.2.8.1 MLT Interface. - The Shelter shall be compatible with the MLT interface requirements as defined by Grumman Specification TBD.

3.2.8.2 MSS Interface. - The Shelter shall be compatible with the MSS interface requirements as defined by Grumman Specification TBD.

3.3 Design and Construction. -

3.3.1 General Design Features. -

3.3.1.1 Configuration. - The overall features and dimensions of the baseline vehicle are shown in Figure 9. The detailed configuration of each vehicle will be defined in the individual vehicle end-item specifications.

3.3.1.2 Weight. - The total weight of the vehicle including payload and expendables will be defined in the individual vehicle end-item specifications.

3.3.2 Selection of Specifications and Standards. - Specifications and standards shall be selected from released lists of NASA, Federal, Military, Industry (trade associations) and Grumman Specifications and standards in that order of preference. Requirements of specifications and standards selected shall not be less stringent than those imposed by the application and the reliability goal specified for the parts, material, or processes covered.

3.3.3 Materials, Parts and Processes. - Materials, parts and processes shall be selected to meet the requirements of the specifications and standards chosen in accordance with 3.3.2. Compliance with requirements of applicable specifications or standards shall be demonstrated by test data or analysis.

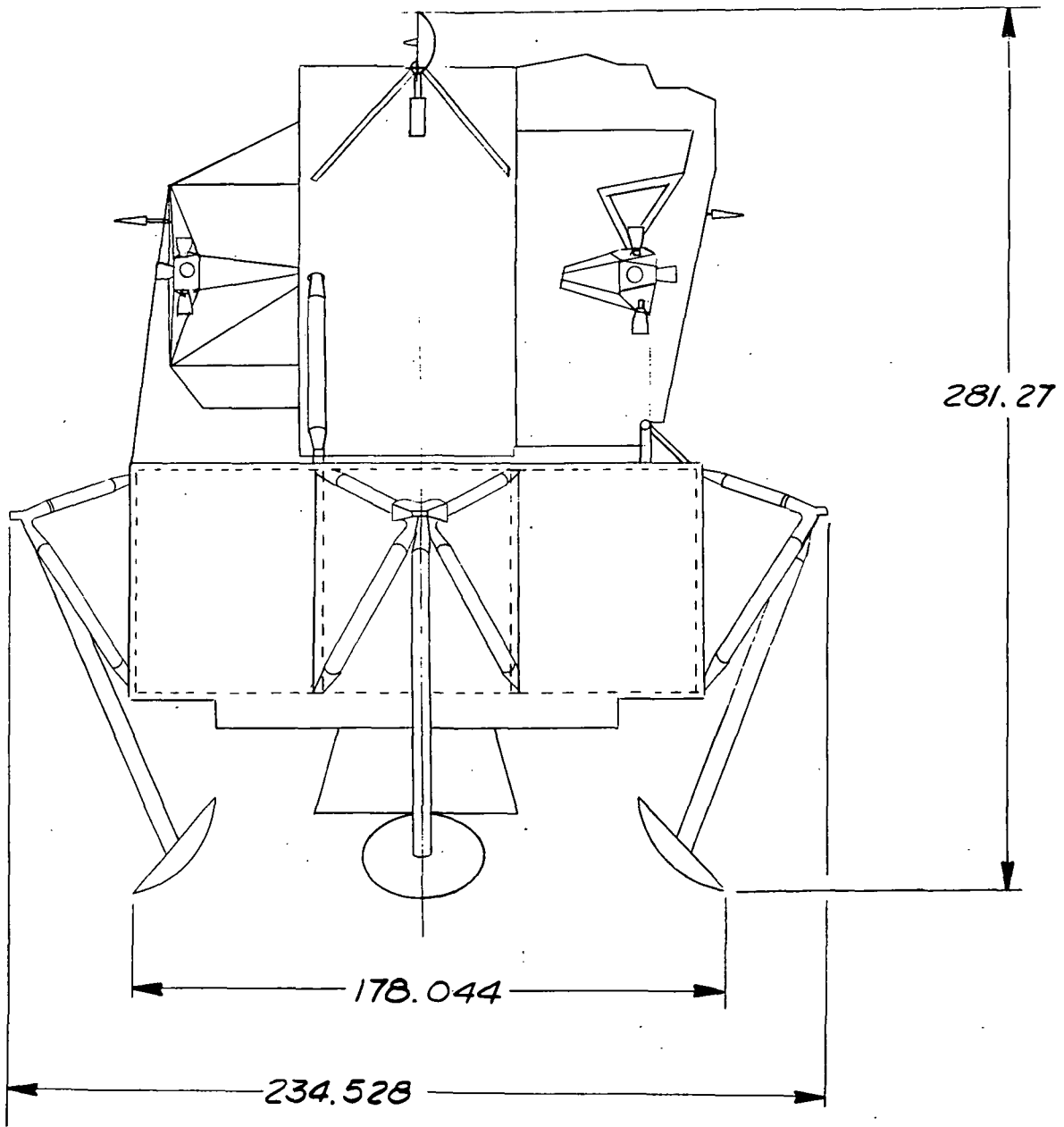

SIDE ELEVATION

P.47
①

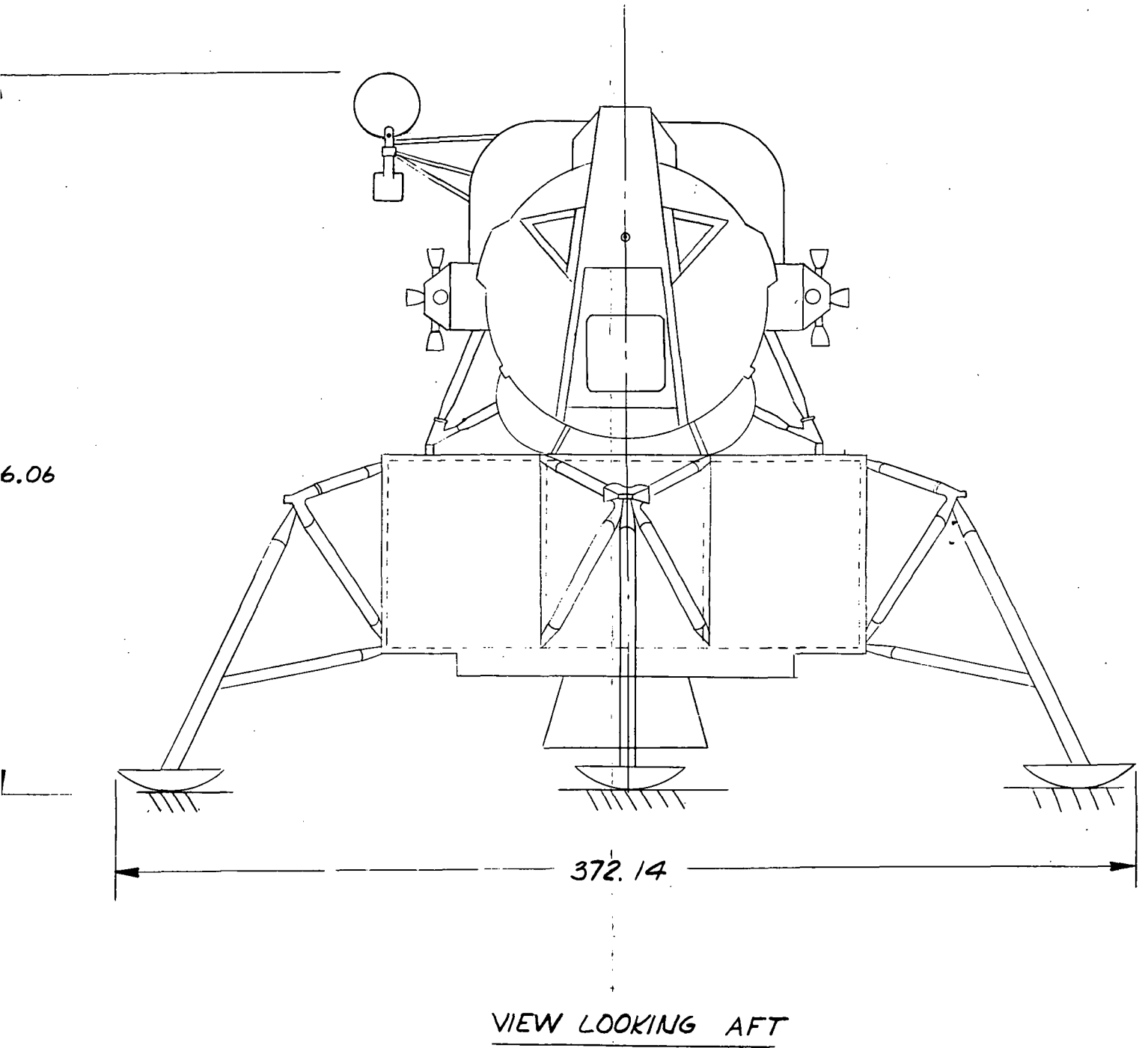

Fig. 9 Vehicle Design

2

Grumman

SPECIFICATION NO. ESP 13-0100

3.3.3.1 Soldering. - Soldering requirements conforming to MSFC-PROC-158 as amended by MSC-ASPO-S-5B shall be complied with.

3.3.3.2 Wiring. - The fabrication and installation of the vehicle cabling and wiring for the interconnection of electrical and electronic equipment shall be in accordance with Grumman Specification LSP-390-002 as modified for the AES.

3.3.4 Standard and Commercial Parts. - Parts shall be selected on the basis of adequate data history with demonstrated reliability and knowledge that they are qualified for a given application selected from sources practicing proven reliability and quality control procedures in their manufacture. Parts qualified to the applicable MIL Specifications shall be selected when a need for such parts exists. IDEP files and other similar sources of information relating to the selection of parts and their application will be used wherever possible.

3.3.5 Mositure and Fungus Resistance. - Materials which are nutrient to fungus shall only be permitted in hermetically sealed assemblies. In other applications, non-nutrient materials shall be used. However, if it is necessary to use nutrient material in an assembly which is not hermetically sealed, the material shall be treated such that it will be capable of satisfactorily passing the fungus test specified in MIL-STD-810.

3.3.6 Corrosion of Metal Parts. - Metal parts shall be of corrosion resistant materials, or shall be processed to resist corrosion. Such corrosion resistant processes shall not prevent compliance with Grumman Specification LSP-390-001.

3.3.7 Interchangeability and Replaceability. - Mechanical and electrical interchangeability shall exist between like items having the same manufacturer's part number. Substitution of like assemblies and replaceable parts shall be easily effected without physical or electrical modification of any part of the equipment, including cabling and wiring.

3.3.8 Workmanship. - Workmanship shall be performed in a high grade manner in accordance with the applicable drawings, specifications, and standards. Processes and manufacturing methods, not covered by specifications, shall be suitable for the article, and workmanship shall be

SPECIFICATION NO. ESP 13-0100

3.3.8 (Continued)

in accordance with high grade spacecraft practice. The quality of workmanship shall not degrade the reliability, performance, or life inherent in the design of the article. All surfaces shall be smooth and free from porosity, burrs, chips, dents, and other irregularities.

3.3.9 Electromagnetic Interference. -

3.3.9.1 Vehicle Interference Control. - The vehicle shall satisfy the requirements of MIL-E-6051C with the following exceptions:

- (a) Delete "MIL-I-26600" and substitute Grumman Specification "LSP-530-001 as modified for AES" in all places.
- (b) Delete "MIL-B-5087" and substitute Grumman Specification "LSP-390-001" in all places.
- (c) Delete paragraph 3.1.1.
- (d) Paragraph 4.3.1: Delete reference to "first electrical-electronic weapon system" and "weapon system" and substitute: "appropriate AES Test Article" in two places.
- (e) Paragraph 4.3.2. Delete second sentence and substitute: "The specification compliance test shall be performed on the appropriate AES Test Article."
- (f) Paragraph 4.3.5, add the following: "The 6 db level shall be a requirement where it has meaningful application as determined by Grumman and delineated in the approved test procedure.

3.3.9.2 Vehicle Equipment Interference Control. - AES Vehicle equipment shall satisfy the requirements of Grumman Specification LSP-530-001, as modified for the AES. The modifications to this specification are to be determined.

3.3.10 Identification and Marking. - Identification and marking shall be as specified in Grumman Specification LSP-14-001.

GRUMMAN AIRCRAFT ENGINEERING CORPORATION

Bethpage, L. I., N. Y.
CODE IDENT 26512

SPECIFICATION NO. ESP 13-0100

3.3.11 Storage. - The vehicle and its equipment shall be capable of withstanding a storage period of five years. The storage environments shall be as specified in 3.1.2.4.1 and 3.1.2.8.1.1 for the five year period except where shorter periods of time are specified for certain environments.

3.3.12 Structural Design Criteria. -

3.3.12.1 Margins of Safety. - The vehicle and its equipment shall possess a zero or positive margin of safety.

3.3.12.2 Limit Conditions. - The design limit load envelope shall be established by superposition of the rationally deduced critical loads which occur throughout the mission. The load envelopes shall recognize the cumulative effects of additive type loads. The vehicle shall be capable of performing as required at limit load conditions.

3.3.12.3 Primary Structure Design. - Primary structures shall not require pressure stabilization.

3.3.12.4 Pressure Vessel Design. - Pressure vessels shall be designed to withstand the design internal pressure continuously for a period equivalent to twice the mission duty cycle without permanent deformation.

3.3.12.4.1 Pressure Vessel Design Limit Load. - The pressure vessel design limit loads shall be derived from the combination of the critical loads imposed on it, and the applicable limit pressure. If the internal pressure of a vessel tends to reduce the effects of the critical loads, the resulting reduction in the pressure vessel design limit loads shall not be considered.

NOTE: Limit pressure is defined as the relief valve nominal pressure plus its tolerances, plus the hydrostatic head. For equipment which does not include a relief valve, the limit pressure is the maximum pressure which results from the highest temperature experienced after pressurization.

SPECIFICATION NO. ESP 13-01003.3.12.5 Effects of Transportation, Handling and Storage. -

- (a) Provision which are incorporated to withstand the effects of transportation, handling and storage shall not cause an increase in the weight of the vehicle or its equipment.
- (b) Structural design shall be such that the environments of transportation, handling and storage shall not cause critical loads on the vehicle.

3.3.12.6 Vibration Design Requirements. - The vehicle and its equipment shall be designed to withstand the vibration levels specified in 3.1.2.8 multiplied by the appropriate factors presented in 3.3.12.7. The vibration levels shown in 3.1.2.8 are considered to be the maximum vibration response of the vehicle primary structure to the input excitation occurring during the mission. For the design of the equipment these vibration levels are the inputs from the vehicle primary structure. The modifying effects of the secondary or supporting structure shall be considered in determining vibration levels for both design analysis and test.

3.3.12.6.1 Vibration Amplification Factor. - The vibration motion amplification factor on any portion of the equipment shall be limited to 10, except in special cases which shall be identified by Grumman and approved by NASA.

3.3.12.7 Factors of Safety. - The factors of safety specified below will be applied to the limit loads to attain the proof, yield and ultimate loads.

3.3.12.7.1 Ultimate Factor of Safety. - The ultimate factor of safety for structural design shall be 1.5 except the vehicle landing gear which shall use a factor of 1.35 on all mechanical moving parts. This factor of 1.5 may be reduced to 1.35 for special cases subject to rational analysis and approval by NASA, MSC.

GRUMMAN AIRCRAFT ENGINEERING CORPORATION

Bethpage, L. I., N. Y.
CODE IDENT 26512

SPECIFICATION NO. ESP 13-0100

3.3.12.7.2 Proof Pressure Factor. - The proof pressure factor shall be 1.33 when pressure is applied as a singular load.

3.3.12.7.3 Vibration Factors. - For structural loads the following factors of safety shall be applied to the vibration amplitudes specified in 3.1.2.8.

3.3.12.7.3.1 Factors for Fatigue-Critical Structure. -

NOTE: These factors are used to determine the vibration qualification test levels for "equipment operating" modes.

(a) Prelaunch-Packaged and Unpackaged - Sinusoidal Levels: 1.0 applied to acceleration or double amplitude.

(b) All Mission Phases after Launch -

(1) Sinusoidal levels: 1.3 applied to acceleration or double amplitude.

(2) Random levels: $(1.3)^2$ applied to acceleration spectral density (g^2/cps).

3.3.12.7.3.2 Factors for Strength-Critical Structure. -

NOTE: These factors are included in structural ultimate qualification test levels.

(a) Prelaunch - Packaged and Unpackaged - Sinusoidal Levels: 1.5 applied to acceleration or double amplitude.

(b) All Mission Phases after Launch -

(1) Sinusoidal levels: 1.5 applied to acceleration or double amplitude.

(2) Random levels: $(1.5)^2$ applied to acceleration spectral density (g^2/cps).

SPECIFICATION NO. ESP 13-0100

3.3.12.7.4 Environmental Factors. - The ultimate factor of safety shall be 1.0 for the following natural environments specified in 3.1.2.4:

- (a) Rain
- (b) Salt Spray and Fog
- (c) Sand and Dust
- (d) Fungus
- (e) Temperature

3.3.13 Thermal Design Criteria. - TBD

3.3.14 Radiation Protection. - The level of radiation protection provided shall be that which is inherent in the vehicle structure.

3.3.15 Micrometeoroid Protection. - TBD

3.3.15.1 Penetration Mechanics. - TBD

3.3.16 Modification Criteria. - The design of the vehicle shall be such that modifications to the vehicle will not cause a perturbation of the interfaces with other modules of the AES Spacecraft.

3.4 Requirements of Sub-Areas. - The functional inter-relationship between subsystem of the Shelter and between major assemblies within subsystems shall be as shown in the Level I Functional Diagram (Fig. 10).

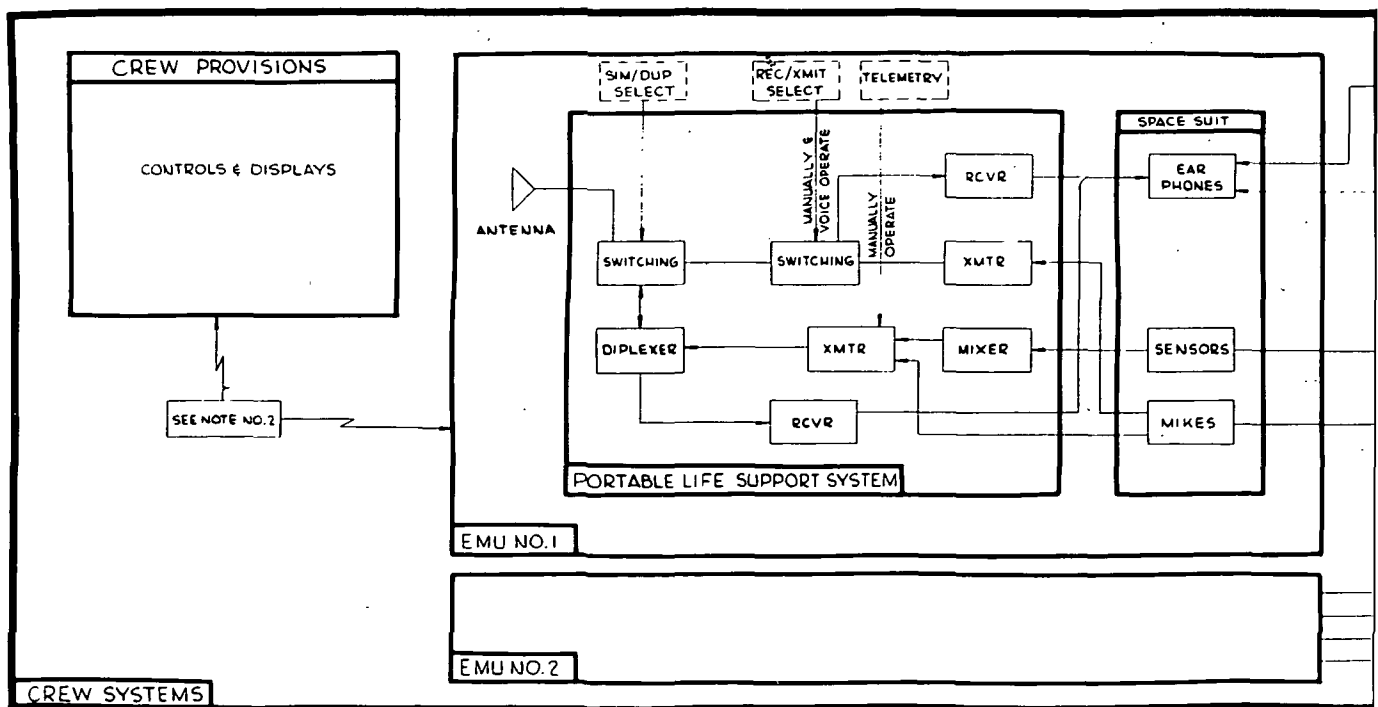
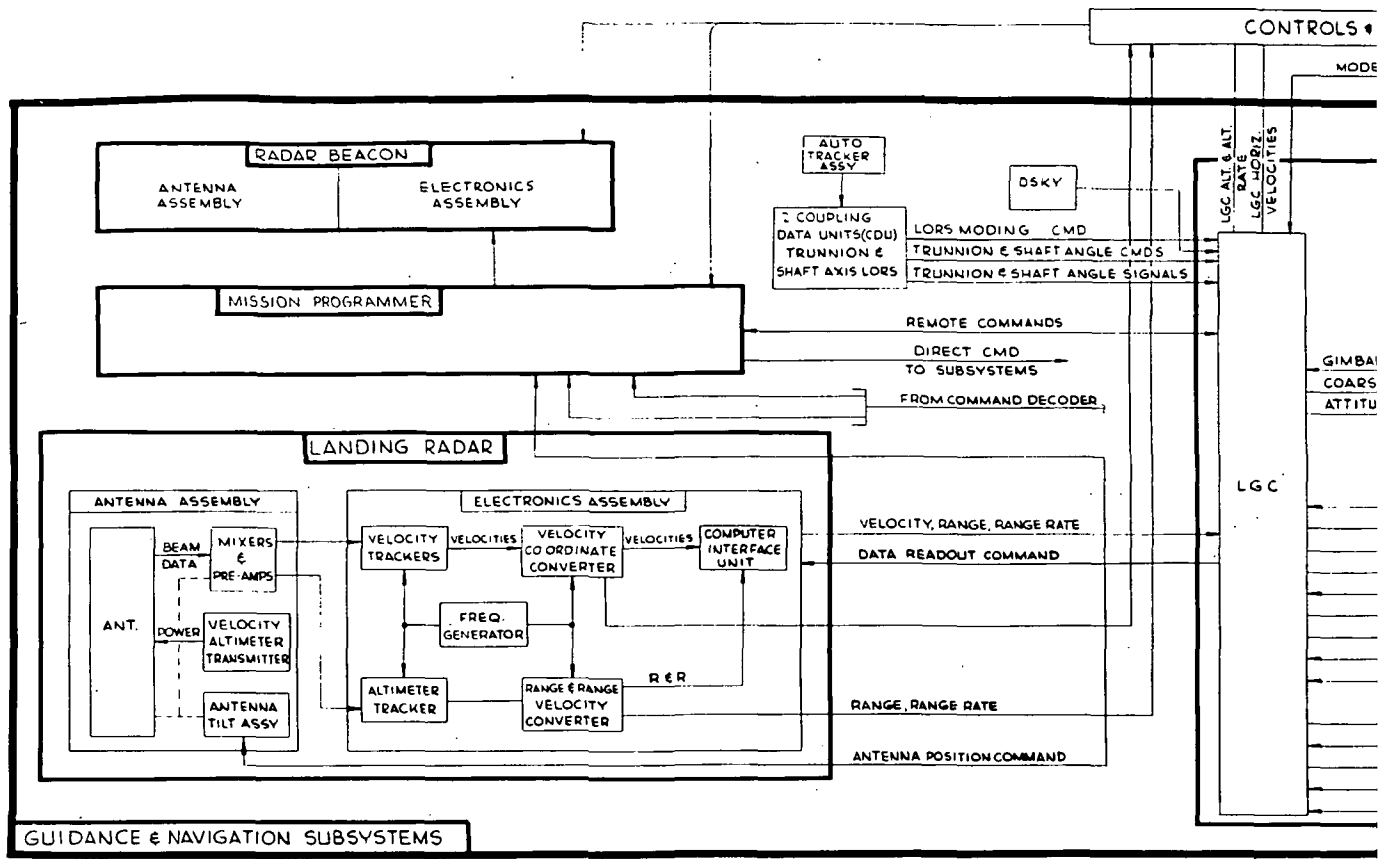

p. 54 ①

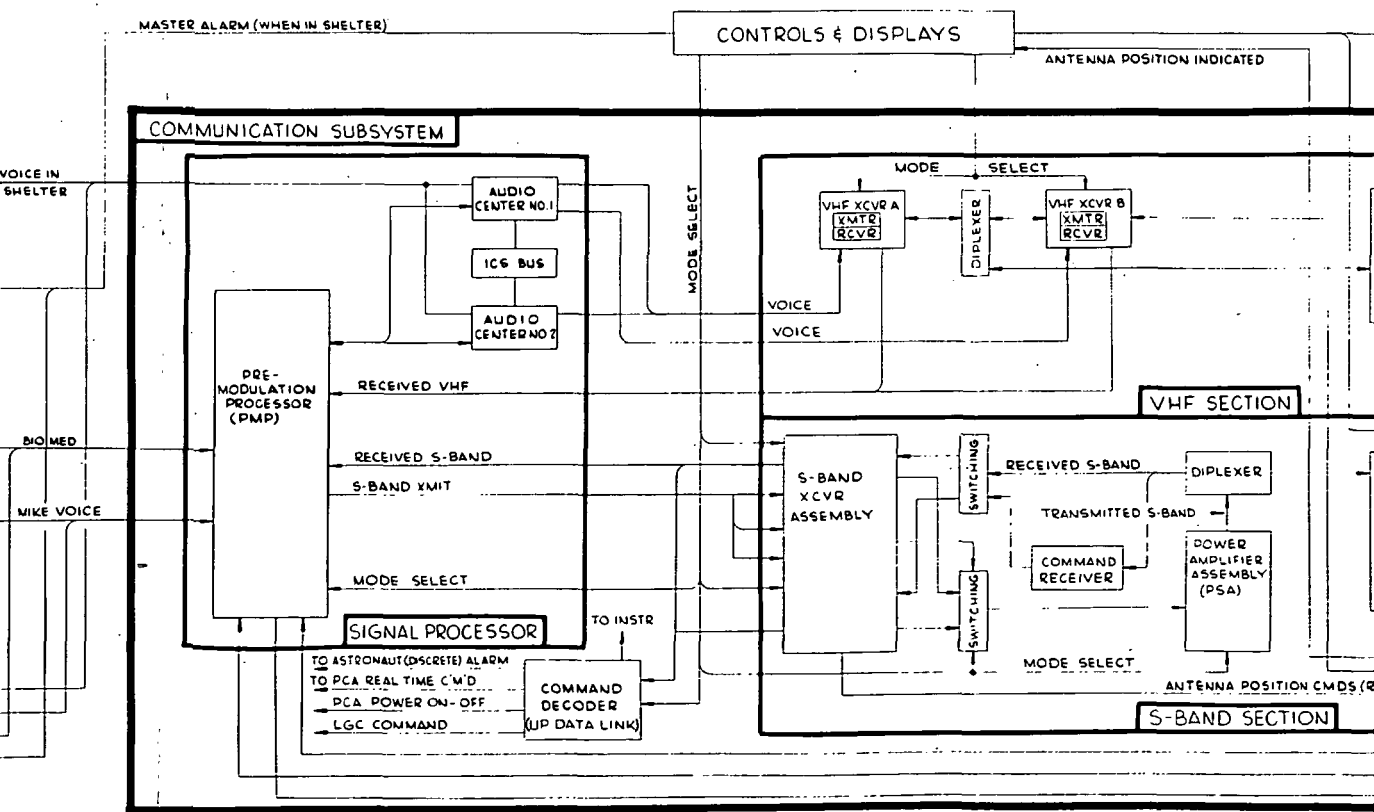
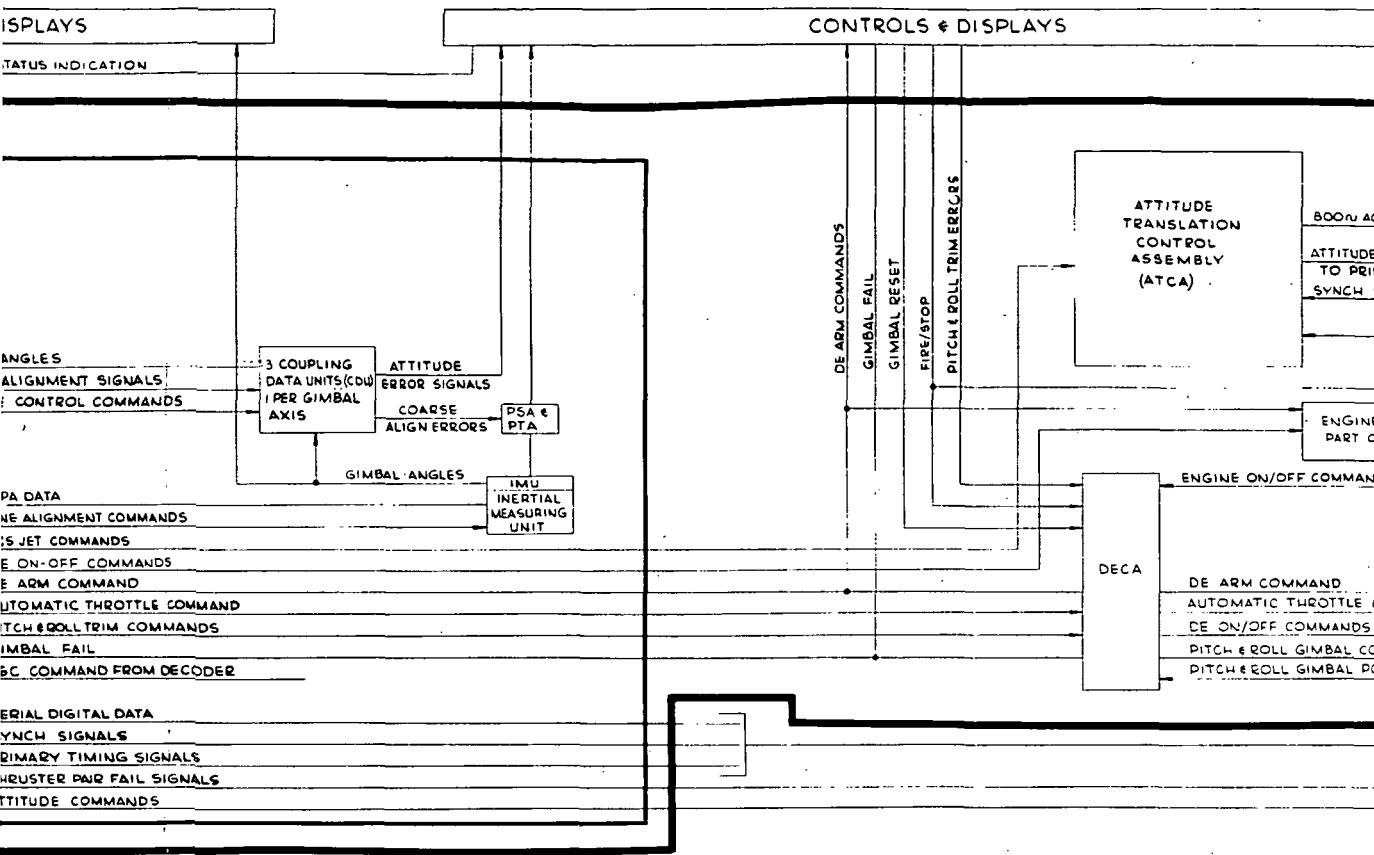

ps4 (2)

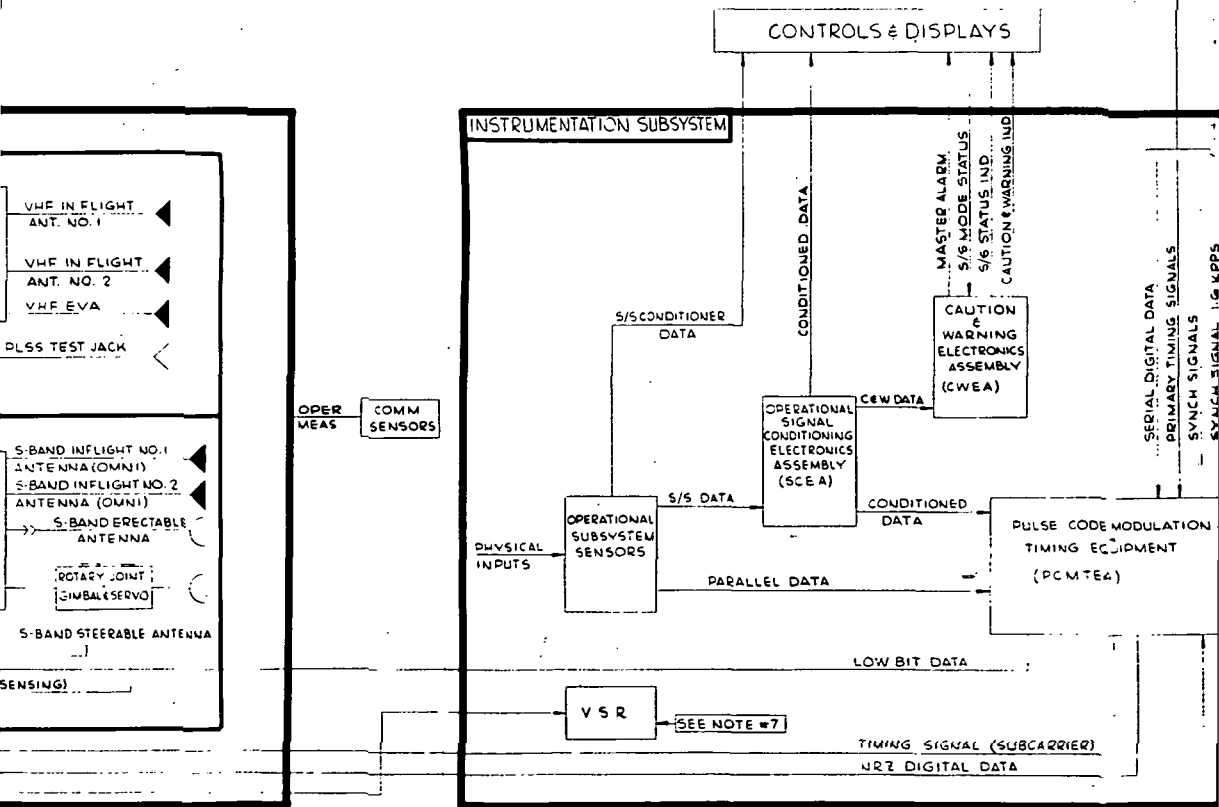
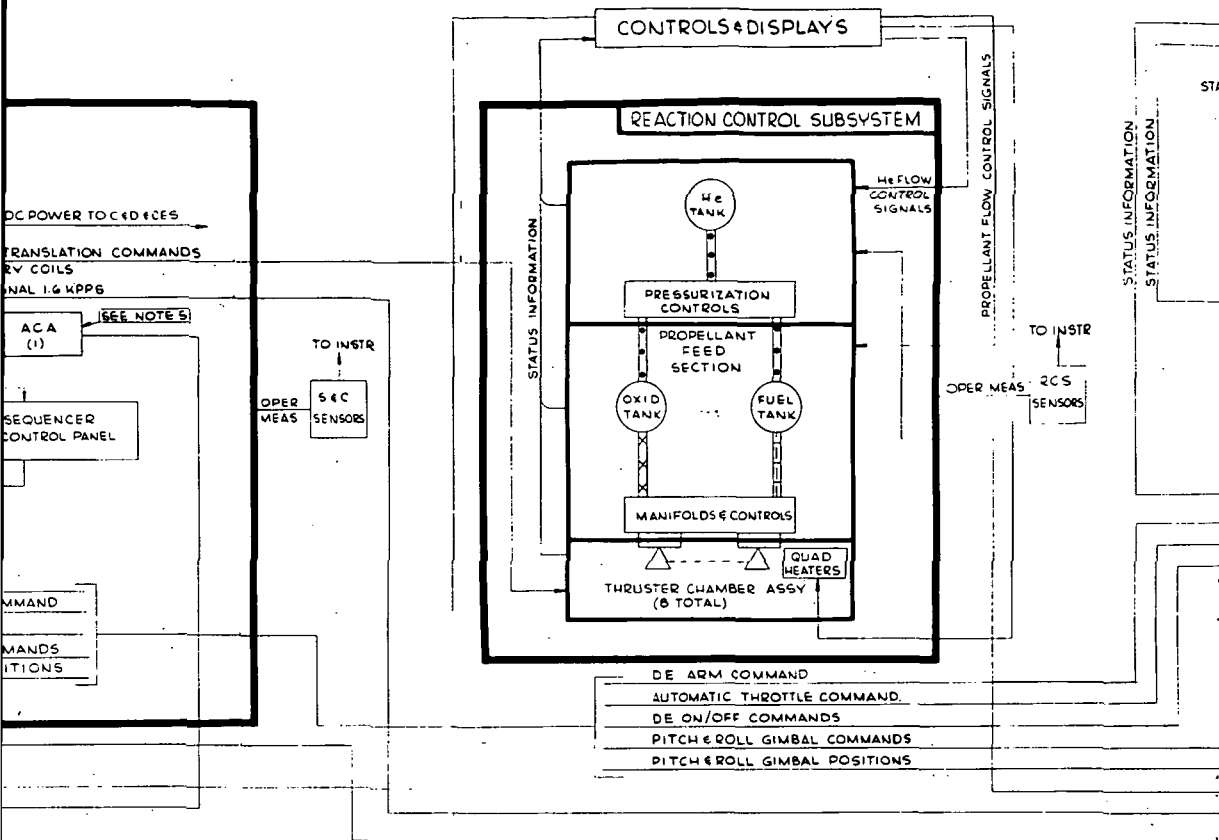

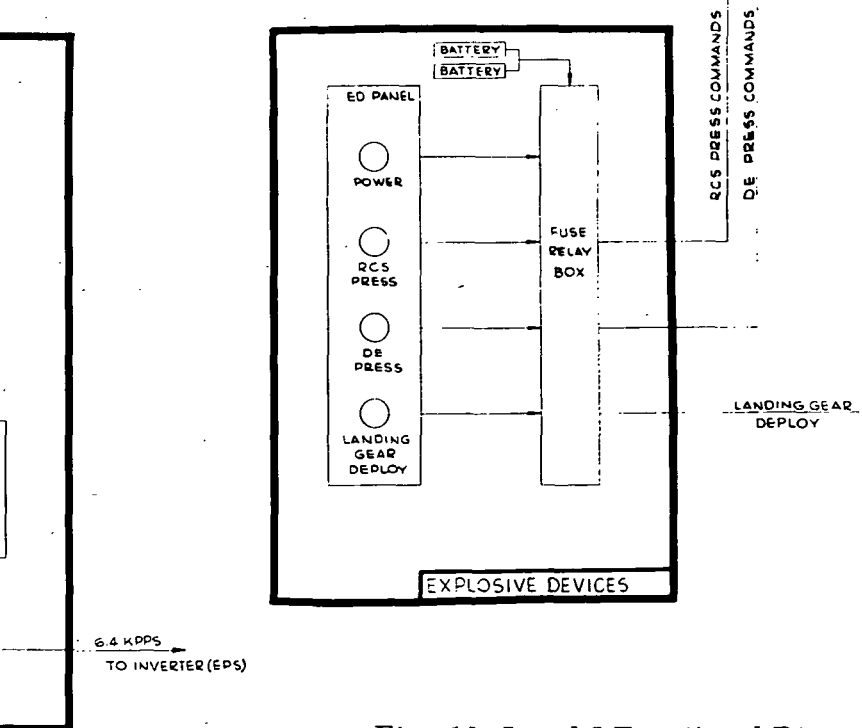
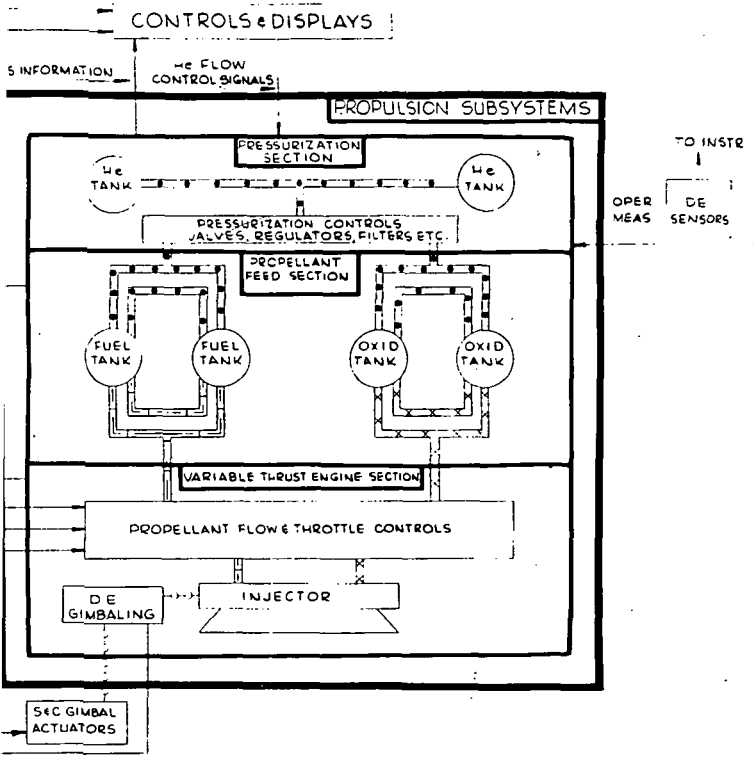
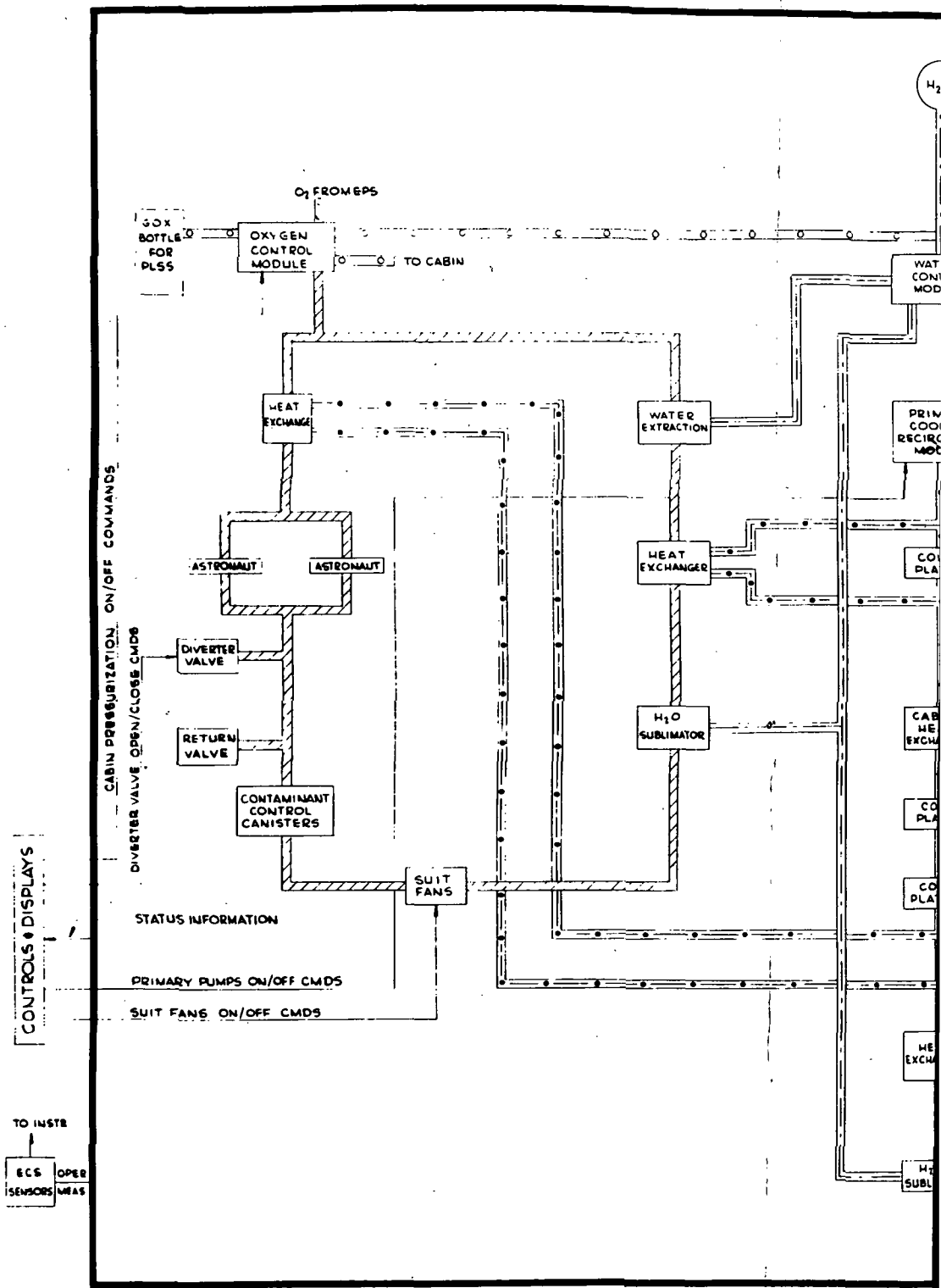
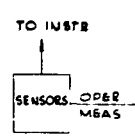
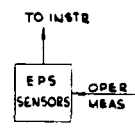
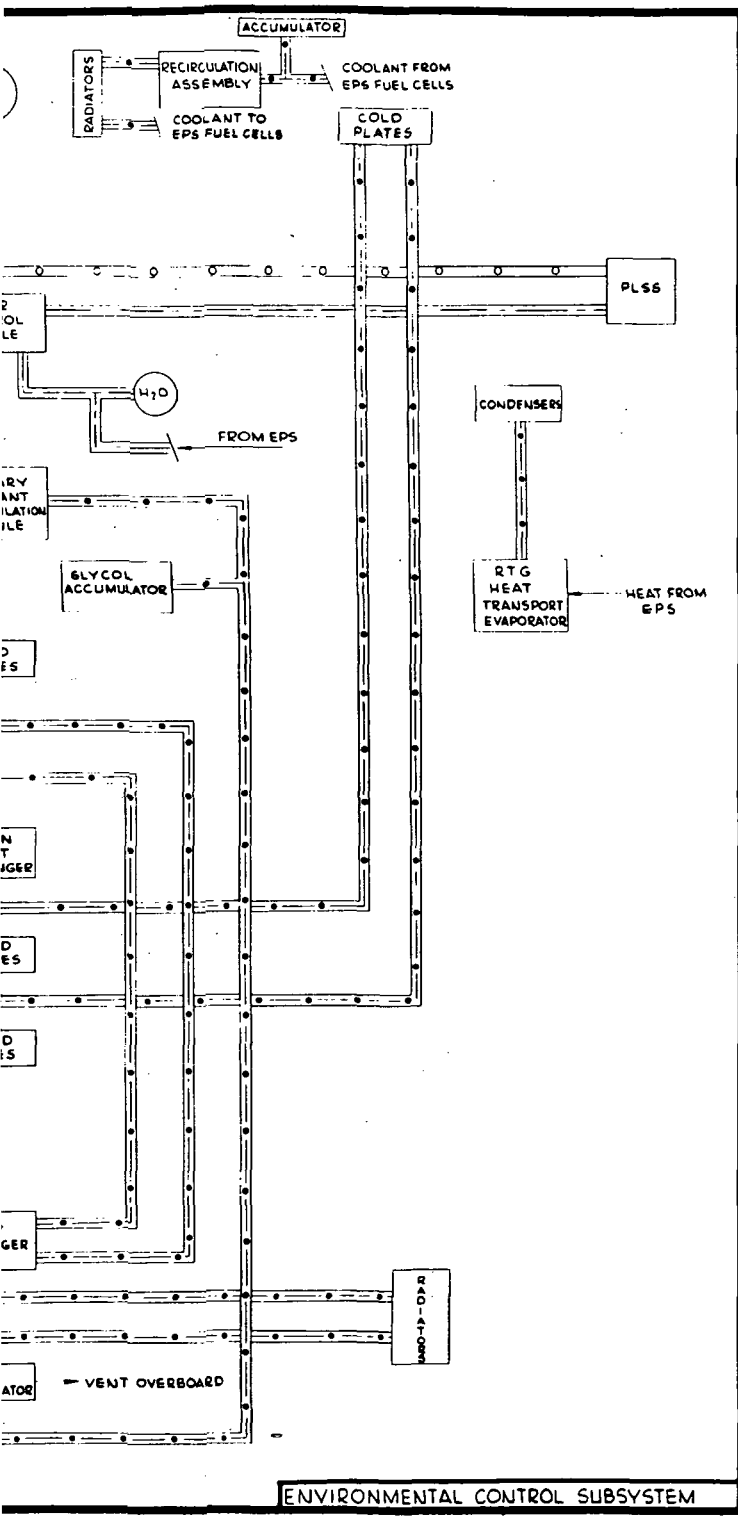

Fig. 10 Level I Functional Diagram for Shelter (Sheet 1 of 2)





P. 55
 ①



P 55
 (2)

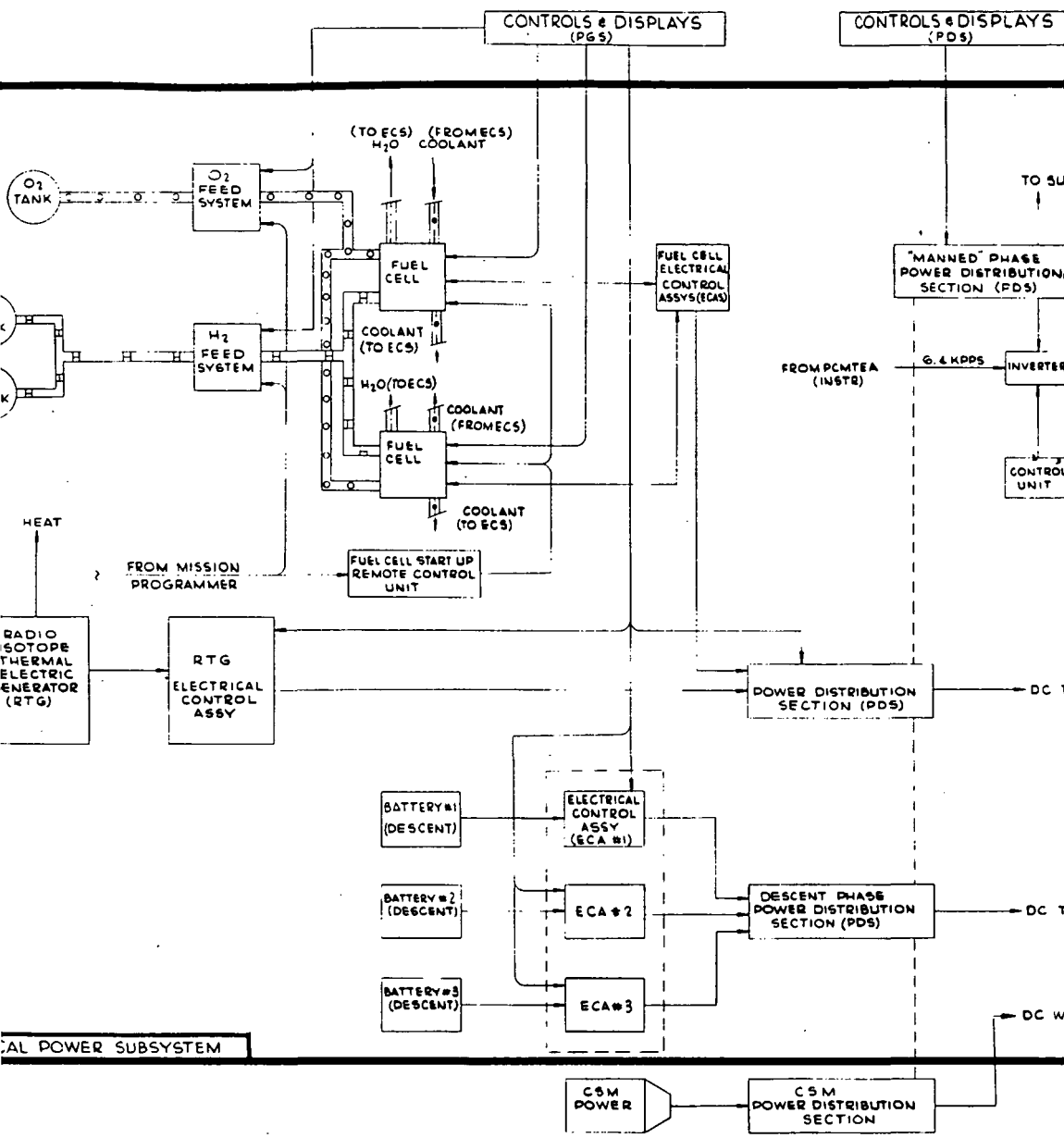

AL POWER SUBSYSTEM

STRUCTURES

55
 (3)









NOTES

1. GENERAL:
THIS IS A TENTATIVE FUNCTIONAL DIAGRAM OF THE AES SHELTER.
2. ADDITIONS TO THE BASIC LEM CONFIGURATION:
 - A) 2 PORTABLE LIFE SUPPORT SYSTEMS (TOTAL 4).
 - B) 14 CONSTANT WEAR GARMENTS
 - C) 4 DOME LIGHT
 - D) WORK STATIONS
 - E) 2 BUNKS
 - F) TOTAL FOOD CAPACITY 78 POUNDS
 - G) THE WASTE MANAGEMENT SYSTEM WILL BE REPLACED WITH THE CSM SYSTEM.
 - H) ADDITIONAL MEDICAL, RECREATIONAL, EXERCISE & MISCELLANEOUS EQUIPMENT.
3. REMOVALS FROM BASIC LEM CONFIGURATION:
 - A) RADIATION DOSIMETERS
 - B) LIQUID COOLED GARMENTS
 - C) BIO-INSTRUMENTATION
 - D) THERMAL GARMENT-EXT
 - E) SUIT REPAIR KIT
 - F) EMERGENCY OXYGEN SYSTEM
 - G) CREW & TIE RESTRAINTS
4. 34 LITHIUM CARTRIDGES HAVE BEEN ADDED (TOTAL 38)
5. ATTITUDE CONTROLLER ASSEMBLY (ACA) WILL BE USED FOR PRIMARY PATH ALIGNMENT & RCS CHECKOUT
6. ADD AIRLOCK
7. THERE ARE TWO VSR'S (ONE SPARE)

ABBREVIATIONS

- RCVR - RECEIVER
 XMIT - TRANSMITTER
 XCVR - TRANSMITTER/RECEIVER
 SIM/DUP - SIMPLEX/DUPLEX
 ATCA - ATTITUDE TRANSLATIONAL CONTROL ASSEMBLY
 DECA - DESCENT ENGINE CONTROL ASSEMBLY
 DC - DIRECT CURRENT
 AC - ALTERNATING CURRENT
 KPDS - KILO PULSE PER SECOND
 DE - DESCENT ENGINE
 FM - FREQUENCY MODULATION
 PM - PHASE MODULATION
 PCM - PULSE CODE MODULATION
 AM - AMPLITUDE MODULATION
 ANT - ANTENNA
 NRZ - NON RETURN TO ZERO
 INSTR - INSTRUMENTATION SUBSYSTEM
 RGA - RATE GYRO ASSEMBLY
 AOT - ALIGNMENT OPTICAL TELESCOPE
 DSKY - DISPLAY KEYBOARD ASSEMBLY
 DEDA - DATA ENTRY DISPLAY ASSEMBLY
 OPER - OPERATIONAL
 MEAS - MEASUREMENT
 ACA - ATTITUDE CONTROL ASSEMBLY
 PRESS - PRESSURIZATION
 LORS - LEM OPTICAL RENDEZVOUS SYSTEM
 VSR - VOICE STORAGE RECORDER
 S/S - SUBSYSTEMS

SYMBOLS

-  - OXYGEN
 - WATER
 - COOLANT
 - CONDITIONED OXYGEN
 - MECHANICAL LINKAGE
 - HELIUM
 - HYDROGEN
 - OXIDIZER

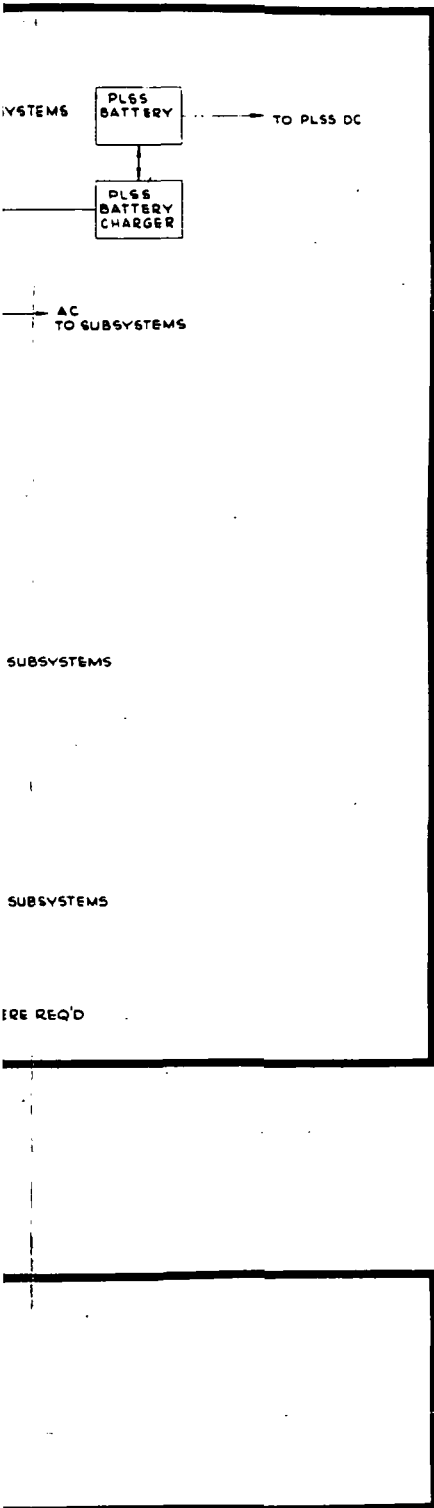

Fig. 10 Level I Functional Diagram for Shelter (Sheet 2 of 2)

SPECIFICATION NO. ESP 13-0100

3.4.1 Structural Design Subsystem (SDS). - The Structural Design Subsystem shall consist of the following major sections:

- (a) Ascent Stage Section Structure, consisting of the Forward Cabin Structure, Aft Cabin Structure, External Equipment Bay Structure, Thermal and Micrometeoroid Shield, and Subsystems Support Structure.
- (b) Descent Stage Section Structure, consisting of Descent Stage Primary Structure, Subsystems Support Structure, and Thermal and Micrometeoroid Shields.
- (c) Landing Gear Section

3.4.1.1 Performance Requirements. -

3.4.1.1.1 Ascent Stage (AS) Section. - The AS Section shall perform the following:

- (a) Provide environmental protection for the AS subsystems and a two man crew during the manned lunar stay and for the AS subsystem equipment during the lunar quiescent period.
- (b) Provide passive thermal control of the AS subsystem equipment environment.
- (c) Provide protection of the AS subsystem equipment from the meteoroid environment.
- (d) Allow adequate visibility for scientific survey of lunar surface during manned lunar stay.
- (e) Provide support for all AS subsystem equipment.

3.4.1.1.2 Descent Stage (DS) Section. - The DS Section shall perform the following:

- (a) Serve as the support for the vehicle in the Spacecraft LEM Adapter (SLA) and provide support for all DS equipment.

SPECIFICATION NO. ESP 13-0100

3.4.1.1.2 (Continued)

- (b) Provide support for the thermal and micrometeoroid shields.
- (c) Provide passive thermal control of DS subsystem equipment except the Electrical Power Subsystem (LEM battery installation, PGT, Fuel Cells) which shall be actively controlled.
- (d) Provide protective shielding for critical DS subsystems from the meteoroid environment.

3.4.1.1.3 Landing Gear Section. - The Landing Gear Section shall perform the following:

- (a) Provide the impact attenuation required to land the vehicle on the lunar surface, prevent tip-over and support the vehicle during the lunar stay. Impact attenuation shall be accomplished to the load levels required to preserve the structural integrity of the vehicle.
- (b) Mounting provisions for an altitude sensing device.
- (c) The forward landing gear primary strut shall provide support points for a ladder in a position beneath the ascent stage forward hatch.
- (d) The landing gear shall be deployed by manual actuation of the gear deployment switch which shall actuate the explosive uplock release device. Preloaded spring driveout mechanisms shall then extend the gear, and latch mechanisms shall secure the gear in the fully deployed position. The landing gear shall be capable of being manually deployed by an extra-vehicular crewman.

3.4.1.2 Design Requirements. -

3.4.1.2.1 Ascent Stage (AS) Section Description. - The Ascent Stage Section shall consist of a pressurized forward cabin, a pressurized aft cabin, and an external equipment bay. The AS Section shall be structurally joined to the Descent Stage at four points. Functional continuity between Descent Stage and Ascent Stage subsystems shall be provided. The Ascent Stage Section shall withstand the environmental conditions encountered during all phases of the Shelter mission. The

SPECIFICATION NO. ESP 13-0100

3.4.1.1.2 (Continued)

Ascent Stage structural design limit-load envelopes shall be established from the critical loads determined by the induced and natural environmental and load conditions.

3.4.1.2.1.1 Forward Cabin Structure. - The Forward Cabin structural shell shall be cylindrical in shape and of semimonocoque construction. It shall be a welded and mechanically fastened assembly of 2219 aluminum alloy sheet, chemilled to appropriate structural thickness, and machined longerons. The shell shall be supported by formed sheet metal rings of channel cross-section riveted to the structural skin. All mechanically fastened joints shall be sealed.

- (a) The front face bulkhead shall be an assembly of integrally stiffened machined parts of 2219 aluminum alloy plate. Two near vertical beams shall support the bulkhead pressure loads and carry forward interstage loads. The front face bulkhead shall contain the forward hatch and the two crew windows.
- (b) The forward windows shall be of dual pane construction. The inner pane shall be structural glass and is designed to carry the cabin pressure loads imposed on it. The window shall be sealed with dual Roco seals, and bolted to the structural window frame through an edge member bonded to the glass using sealing fasteners. Coatings shall be applied to reduce glare and reflections, and defogging provisions incorporated. The outer pane shall be glass, coated to limit thermal transmissions. The forward windows shall provide the visibility range from the design eye position.

SPECIFICATION NO. ESP 13-0100

3.4.1.2.1.2 Aft Cabin Structure. - The structure of the aft cabin shall consist of a ring stiffened semimonocoque shell constructed similarly to the forward cabin. Integrally stiffened machined decks of 2219 aluminum alloy shall be employed to close off the aft cabin assembly. The aft cabin shell shall be mechanically fastened to flanges on major structural bulkheads. These bulkheads shall be integrally stiffened machined bulkheads of 2219 aluminum alloy plate. The forward cabin shell shall be mechanically fastened to the outboard flange of one bulkhead to complete the assembly of the pressurized portion of the AS structure. The upper deck shall provide structural support for the upper docking tunnel and shall contain the upper hatch. The one major bulkhead shall contain provisions for the attachment of the tubular aft interstage structure. The propellant storage tanks shall be mounted between the major bulkheads.

3.4.1.2.1.3 The External Equipment Bay. - The external equipment shall be unpressurized and shall consist of the Electronic Replaceable Assembly Rack and its support structure. The rack shall consist of vertically oriented cold plates mounted in a structural frame. The frame shall be supported at its lower and upper edge by an arrangement of truss members supported on the bulkhead.

3.4.1.2.1.4 Thermal and Micrometeoroid Shield. - The thermal and micrometeoroid shield shall be a composite of an outer sheet of aluminum and multiple layers of aluminized mylar mounted on low thermal conductance supports. The sheet of aluminum shall act as a micrometeoroid bumper and will differ in thickness over the surface to meet shielding requirements.

3.4.1.2.1.5 Subsystem Support Structure. -

- (a) The RCS propellant and helium pressurization tanks shall be modularized and mounted on one side of the aft cabin.
- (b) The Navigation Base (NVB) and the Inertial Measuring Unit (IMU) shall be located on the top center line of the cabin, outside of the pressure shell.
- (c) The External Equipment Bay, shall contain the cold plates for the mounting of the Electronic Replaceable Assemblies (ERA's).

SPECIFICATION NO. ESP 13-0100

3.4.1.2.1.5 (Continued)

- (d) The four RCS thruster clusters shall be supported from the ascent stage primary structure.

3.4.1.2.1.6 Ascent Stage Hatch Mechanism. - The forward and upper hatches shall be hinged to the forward face bulkhead and upper aft cabin deck, respectively. Latches shall be provided to dog the hatches sufficiently to provide an initial seal. The final sealing force shall be supplied by the cabin pressure. The latches shall be operable from either side for depressurization of the cabin.

3.4.1.2.1.7 Airlock. - TBD

3.4.1.2.2 Descent Stage Section Description. - The Descent Stage Section shall withstand the environmental conditions encountered during all phases of the Shelter mission. The Descent Stage structural design limit-load envelopes shall be established from the critical loads determined by the induced and natural environmental and load conditions.

3.4.1.2.2.1 Descent Primary Stage Structure. - The DS structure shall be of aluminum alloy and steel construction and shall consist of two pairs of parallel beams arranged in a cruciform shape with structural decks on upper and lower surfaces. At the ends of each pair of beams shall be a four legged truss to serve as support for the Shelter in the SLA and as the attachment point for the main strut of the landing gear. This truss shall be of aluminum alloy tubular construction. Aluminum alloy fittings shall be provided to serve as the aft attachment points for the Ascent Stage. Aluminum alloy fittings shall be provided to serve as the forward attachment points for the Ascent Stage.

3.4.1.2.2.2 Thermal and Micrometeoroid Shield. - The thermal shielding for the descent stage shall be a composite of the outer micrometeoroid shield, thermal coatings, and multiple layers of aluminized mylar mounted on low thermal conductance supports. The base heat shield, in addition to the normal environmental requirements, shall protect the descent stage structure and equipment from descent engine thermal radiation and plume impingement.

SPECIFICATION NO. ESP 13-0100

3.4.1.2.2.3 Subsystem Support Structure. - The compartments formed by the Descent Stage structural arrangement shall house the equipment required by the subsystems. The equipment, as a minimum shall include:

- (a) Descent Propellant Tanks
- (b) Oxidizer Tanks
- (c) Fuel Tanks
- (d) Helium Tanks
- (e) S-Band Erectable Antenna
- (f) Landing Radar Antenna Components
- (g) ECS Water Tank
- (h) Descent Engine Control Assembly
- (i) PLSS and EPS Gaseous Oxygen Tanks
- (j) EPS Gaseous Hydrogen Tanks
- (k) Supercritical Helium Tank
- (l) Batteries
- (m) Control Assemblies
- (n) Scientific Equipment

3.4.1.2.3 Landing Gear Subsystem Requirements. - The landing gear shall be designed to withstand limit loads determined from the induced and natural environmental and load conditions without deformations which might compromise the performance of the gear. Ground handling loading environment shall not exceed landing environment. The landing gear stability performance shall include the effects of a 1500 pound

SPECIFICATION NO. ESP 13-0100

3.4.1.2.3 (Continued)

average descent engine nozzle crushing load. The design requirements shall include, as a minimum, the following:

- (a) Requirements for crushing load and available stroke will be of correct values to satisfy stability and energy absorbing criteria of the cartridges that are contained in the energy absorbing struts. The variation of cartridge properties with velocity and temperature possibilities and other effects will be included.
- (b) Loads sustained by gear structural components are basically limited by the crush loads of the individual energy absorbing struts. For design of all the gear structural components, the most critical combinations of struts, loads, and geometry will be used.
- (c) The effects of velocity will be accounted for insofar as cartridge load and structural response are affected.
- (d) The landing gear shall have the capability of manual retraction with a clearance-fit in the stowed position with the uplock mechanism. There shall be sufficient clearance within the spacecraft LEM adapter and the SIVB instrument unit during and throughout the entire LEM/SIVB separation event.
- (e) The landing gear shall be configured such that no portion of the Descent Stage will contact any lunar surface protuberance as specified in 3.1.2.4.3.4. Criteria used for determining ground clearance shall be based on gear deflection derived from landing dynamics and not from geometrically possible gear deflections.

SPECIFICATION NO. ESP 13-0100

3.4.1.2.3.1 Landing Gear Structure Design. - The landing gear structure shall consist of four gear assemblies attached to the descent stage at the vehicle support outrigger positions. In the initially deployed configuration the radius of the circle through the pad attachment points shall be 167.57 inches. Each gear assembly shall be a cantilevered gear of tubular (AL Alloy) construction capable of being retracted and shall consist of the following:

- (a) The primary strut shall consist of a piston-cylinder device which shall produce suitable load-stroke characteristics when stroked in compression. The primary strut upper end shall attach to the descent stage outrigger fitting and the lower end shall provide a ball joint support for the foot pad.
- (b) Each secondary strut shall consist of a piston cylinder device which shall produce suitable load-stroke characteristics when stroked in both tension and compression. The outboard end of each secondary strut shall attach to the primary strut outer cylinder and the inboard end of each secondary strut shall attach to the deployment truss.
- (c) Shock absorbers shall be of a crushable material capable of providing the necessary load-stroke requirements and shall be installed in each primary and secondary strut.
- (d) The footpad shall provide for vehicle flotation on a 12 psi bearing strength surface under the maximum gear reaction force. Each footpad shall support a lunar surface sensing probe. See (e)(4).
- (e) The landing gear mechanisms shall consist of the following:
 - (1) There shall be one "uplock" device provided for each landing gear assembly and it shall be installed between the descent stage and the primary strut. The "uplock"

SPECIFICATION NO. ESP 13-0100

3.4.1.2.3.1 (Continued)

(e) (1) (Continued)

device (explosively actuated) shall be installed with sufficient pre-load tension to adequately restrain the landing gear in the stowed position under all vibratory and shock conditions. A manually operated switch in the crew station shall electrically actuate initiators on all "uplocks" allowing the unlocked gear assemblies to be deployed with the deployment mechanism.

- (2) The deployment mechanism on each landing gear assembly consists of a deployment truss, deployment spring devices and connecting linkages. The deployment mechanism spring devices and connecting linkage shall deploy the landing gear from the stowed position to the fully deployed (gear locked down) position, by continuously driving through this entire travel. The mechanisms shall be so arranged that either of the two spring devices shall deploy the gear to the gear locked down configuration from any standstill position. The impact of the landing gear extension due to the stored spring energy of two springs per assembly shall be absorbed by structure.
- (3) The landing gear deployer (gear locked down) mechanism consists of two spring loaded locks per landing gear assembly, capable of sustaining balancing loads imposed on the deployment frame during landing. The landing gear down locks shall secure the deployment truss in the deployed configuration. "Down" lock springs (one for each lock) shall retain the lock in the secured position under all vibratory and shock loads. Each lock shall contain provisions for two independent electric switches that are actuated when the lock is in the landing gear locked down position. The landing gear deployed indicator in the crew station shall indicate a safe condition (all landing gear assemblies locked down) when at least one switch on each of eight down locks has been actuated.

SPECIFICATION NO. ESP 13-0100

3.4.1.2.3.1 (Continued)

(e) (Continued)

- (4) A lunar sensing probe shall be provided on each footpad. The probe shall be retained in stowed position until the landing gear is deployed. At this time the mechanical interlock shall release allowing spring energy of the self-erecting probe to extend. The probe shall have sufficient length from the bottom of the footpad to permit indication for descent engine shut-off switch actuation within the permissible landing performance envelope. The probe shall provide sufficient contact area to permit indication on a 12 psi surface.

3.4.2. Electrical Power Subsystem (EPS). -

3.4.2.1 EPS Performance. - The Electrical Power Subsystem shall generate, distribute and control the total available electrical energy for the Shelter. The total available energy for the Shelter, exclusive of the CSM supplied energy shall be 5.1 kwh from pre-launch to touchdown; 103.0 kwh during quiescent storage; and 501.5 kwh during Shelter checkout, activation and manned phase.

3.4.2.1.1 Electrical Power Characteristics. - Power characteristics sensed at the load shall be as follows:

- (a) DC Power: The d-c power shall be 28 vdc, two wire negative ground with the following characteristics:
- (1) Steady-State Voltage Limits: 22 to 33 volts
 - (2) Transient Voltage Limits: (superimposed on 28 vdc)
 - a. Positive: 50 volts for ten microseconds at ten pps repetition rate for a period of five minutes.

SPECIFICATION NO. ESP 13-0100

3.4.2.1.1 (Continued)

(a) (2) (Continued)

b. Negative: 100 volts for ten microseconds at ten pps repetition rate for a period of five minutes.

(3) Ripple: As defined by MIL-STD-704 except that the maximum sum of the peak a-c ripple and d-c voltage shall be 33.0 volts.

(b) A-C Power:

(1) Phases: Single phase.

(2) Nominal Steady-State Voltage: 115 plus or minus two volts rms.

(3) A-C Voltage Transients: The a-c voltage shall recover to a minimum voltage of 144 volts peak or to a maximum voltage of 188 volts peak within 2.5 milliseconds, and return to steady-state conditions within 50 milliseconds, after experiencing an input line or load step change within the limits specified for line and load. Voltage spikes superimposed at any point of the sinusoidal wave shape shall not exceed 10 volts peak. The maximum transient voltage at the output shall not exceed 225 volts peak.

(4) Modulation: 2.5 volts single amplitude.

(5) Nominal Frequency Tolerance:

a. Normal: 400 plus or minus 4 cps (synchronized to master timing)

b. Free Running: 400 plus or minus 10 cps (loss of master timing)

SPECIFICATION NO. ESP 13-0100

3.4.2.1.1 (Continued)

(b) (Continued)

(6) Wave Shape: Sine wave

- a. Maximum Total Distortion: 5 percent
- b. Highest Harmonic: 4 percent
- c. Crest Factor: 1.414 plus or minus 10 percent

3.4.2.1.2 Power Profile. - The power profile will be supplied at a later date.

3.4.2.2 Design Requirements. - The EPS shall include the following major assemblies:

- (a) Electrical Control Assembly
- (b) Batteries
- (c) Static Inverters - General Purpose
- (d) Power Distribution Section
- (e) Fuel Cell Assemblies (FCA)
- (f) Radioisotope Thermoelectric Generator/Power Conditioning Package (RTG/PCP)
- (g) Battery Charger (BC)
- (h) Reactant Storage and Supply Section
- (j) Radiator

3.4.2.2.1 Electrical Control Assembly. - One ECA shall be provided for control of each FCA and battery. Each ECA shall include

SPECIFICATION NO. ESP 13-0100

3.4.2.2.1 (Continued)

the necessary electrical and electronic equipment for manual or automatic control of the FCA and battery power output to the Shelter Power Distribution Section. Upon receipt of signals from the Shelter control panel, the ECA shall control the "on-off" condition of the FCA's or batteries. The ECA shall provide overcurrent and reverse current sensing and protection. The trip characteristics are to be determined.

3.4.2.2.2 Batteries. - A portion of the electrical power shall be provided by three silver-oxide-zinc batteries. Each battery shall supply 12.0 kwh.

3.4.2.2.2.1 Battery Performance. - The battery voltage shall be as follows:

- (a) Maximum Voltage: 32.5 volts, during all discharges.
- (b) Nominal Voltage: 30.0 volts.
- (c) Minimum Voltage: 28.0 volts, during all discharges.

A low voltage tap will be used, if required, to enable the battery to achieve the above specified voltage requirements.

3.4.2.2.2.1.1 Capacity. - The battery shall have a capacity of not less than TBD ampere-hours when discharged at TBD amperes at 80 degrees Fahrenheit. These requirements are based upon a minimum of 28.0 volts.

3.4.2.2.2.1.2 Parallel Operation. - The voltage requirements of 3.4.2.2.5.1, 3.4.2.2.2.1 and 3.4.2.2.2.1.1 shall be satisfied when the FCA's and batteries are operated in parallel.

3.4.2.2.3 Static Inverters. - The two static inverters shall be solid state devices that convert 28 volts d-c (nominal) electrical power to 115 volts a-c, single phase, 400 cps (nominal). Either inverter shall have the capability of supplying a-c power to its assigned loads with the other serving as a redundant standby unit.

SPECIFICATION NO. ESP 13-0100

3.4.2.2.3.1 Mounting. - The inverters shall be rigidly mounted.

3.4.2.2.3.2 Input Power. - Rated input voltage shall be 28 ± 4 volts d-c. The inverter shall operate but need not meet performance requirements when the input voltage falls below 20 volts d-c for five seconds or longer.

3.4.2.2.3.3 AC Power Output Characteristics. -

- (a) Voltage output: 117 volts rms, single phase, 400 cps.
- (b) Steady-State voltage regulation: ± 1 percent at the a-c terminals of the mating connectors.
- (c) Normal load requirements: 0 to 350 volt amps at power factors ranging from 0.65 lagging to 0.80 leading.
- (d) Low power factor load requirements: Up to 120 volt amps at power factor ranging from 0.8 to 0.10 leading.
- (e) AC Voltage transients - The a-c voltage shall recover to a minimum voltage of 144 volts peak or to a maximum voltage of 188 volts peak within 2.5 milliseconds, and return to steady-state conditions within 50 milliseconds, after experiencing an input line or load step change within the limits specified for line and load. Voltage spikes superimposed at any point of the sinusoidal wave shape shall not exceed 10 volts peak. The maximum transient voltage at the output shall not exceed 225 volts peak.
- (f) Frequency - Two modes of operation shall be provided:
 - (1) Externally synchronized mode - The frequency of the inverter shall be 400 ± 4 cps with an externally supplied synchronizing signal.
 - (2) Free-running mode - In the absence of the external synchronizing signal the inverter shall maintain a free-running frequency of 400 ± 10 cps.
- (g) Isolation - The a-c output shall be electrically isolated from the d-c input and from the case, except for the RFI feed-through capacitors which may be grounded to the case.

SPECIFICATION NO. ESP 13-0100

3.4.2.2.3.4 Overload. - The Inverter shall provide up to 150 ± 5 percent of the maximum load requirements specified in 3.4.2.2.3.3 for a period of ten minutes. During the overload condition the Inverter shall satisfy its performance requirements and shall incur no damage. The Inverter shall automatically limit the output current to a maximum of 330 ± 10 percent of the maximum load requirements specified in 3.4.2.2.3.3 and shall be capable of withstanding this overcurrent condition for 20 seconds without damage and resuming normal operation when the overload is removed.

3.4.2.2.4 Power Distribution Section. - Power distribution shall be accomplished by a two wire grounded system for d-c loads and a single phase system for a-c loads. Wire and buses shall be employed as the return path for electrical currents, rather than the spacecraft structure. The system negative and neutral shall be grounded at one point only.

3.4.2.2.4.1 Load Grouping. - D-C electrical loads shall be connected to a common two-section, electrically connected d-c bus. Provisions shall be made for disconnecting one section of the bus from the other in the event of a failure. Loads shall be grouped into two sections and in the event of a failure and subsequent disconnection of the busses, electrical power will continue to be supplied to the operating bus. A-C loads shall be supplied from a single a-c bus. The bus configuration shall be as shown in Figure 11.

3.4.2.2.4.2 Electrical Distribution Panels. - The distribution panels shall be adequately enclosed or otherwise protected to minimize hazards to the crew and provide maximum mechanical protection for the electrical system and components. Switching and control shall be accomplished by manually operated circuit breakers or switches, except where use of a remotely controlled device will reduce weight or increase reliability.

3.4.2.2.4.3 Power Interruption Protection. - Buses and electrical loads shall be selectively protected such that individual load faults will not cause an interruption of power on the bus to which the load is

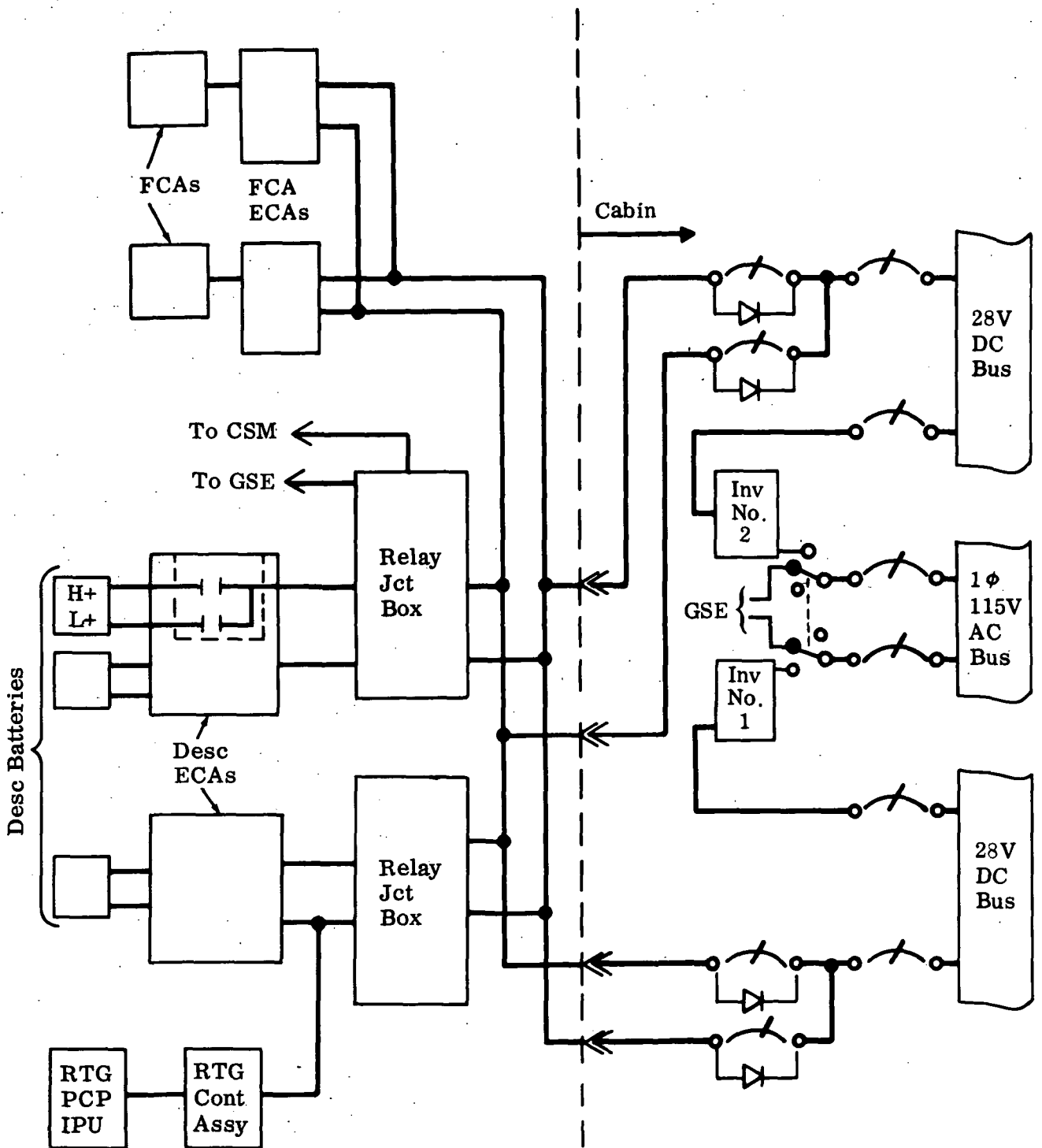

Fig. 11 Electrical Distribution System Block Diagram

SPECIFICATION NO. ESP 13-0100

3.4.2.2.4.3 (Continued)

connected. The d-c bus shall be protected from a fault in a battery or its power feeder by the Electronic Control Assembly (ECA) and the tie-in control circuit. The bus ties connecting the two d-c busses shall be protected on either end by a circuit protective device. In the event of an interruption of a-c power on the a-c bus shall be transferred to the standby Inverter.

3.4.2.2.4.4 Power Distribution Equipment. - The power distribution equipment shall be capable of being energized by the following external power:

(a) DC: 28.5 to 32.5 volts.

(b) AC: 115 volts nominal.

3.4.2.2.5 Fuel Cell Assembly (FCA). - The primary source of electrical power for the Shelter during checkout, activation and manned phases shall be supplied by two FCA's. Each FCA shall consist of a 33 section module which chemically combines hydrogen and oxygen to produce useful power with potable water and waste heat as by-products. Each FCA shall be capable of delivering a maximum power of TBD watts and shall contain provision for collection and storage of the water as well as rejection of the waste heat to the vehicle coolant loop.

3.4.2.2.5.1 FCA Performance. - FCA output voltages shall be as follows:

(a) Maximum Voltage: 32.5 vdc

(b) Minimum Voltage: 28 vdc

3.4.2.2.5.1.1 Step Load Change. - The step load damage capability of the FCA is the maximum instantaneous increase or decrease in power which the FCA may be subjected to while continuously supplying voltage within the specified limits of 3.4.2.2.5.1. The FCA shall have a step load change capability as shown in Figure 12.

3.4.2.2.5.1.2 Parallel Operation. - The voltage requirements of 3.4.2.2.5.1 shall be satisfied when the FCA's are operated in parallel.

SPECIFICATION NO. ESP 13-0100

TBD

FUEL CELL STEP LOAD CHANGE CAPABILITY

FIGURE 12

SPECIFICATION NO. ESP 13-0100

3.4.2.2.5.1.3 Reactant Consumption Rate. - The reactant consumption rate for the FCA shall not exceed the values shown in Figure 13.

3.4.2.2.5.1.4 Water Generation. - The FCA shall be capable of generating potable water with ph factor between 6 and 8.

3.4.2.2.1.5 Heat Rejection. - The heat rejection rate for the FCA shall not exceed the values shown in Figure 14.

3.4.2.2.6 Radioisotope Thermoelectric Generator/Power Conditioning Package (RTG/PCP). - The RTG/PCP shall supply a portion of the electrical power required for the Shelter during the quiescent mode. The RTG/PCP shall utilize a radioisotope fuel as a heat source and thermoelectric elements as electrical power generators, with waste heat as a by-product. The RTG/PCP shall provide a total of 79.7 kwh.

3.4.2.2.6.1 RTG/PCP Performance. - The RTG/PCP output voltages shall be as follows:

- (a) Maximum Voltage: 31.1 vdc.
- (b) Minimum Voltage: 30.5 vdc.
- (c) Conditioned Power: Up to 50 watts.

3.4.2.2.6.2 Heat Rejection. - The heat rejection rate for the RTG/PCP shall not exceed 1300 thermal watts.

3.4.2.2.7 Battery Charge (BC). - A Battery Charger shall be provided for recharging the PLSS batteries. The BC shall provide a maximum output voltage of 40.5 vdc and provide a charging current of 3.5 ± 0.1 amps. The BC shall automatically cut off when the battery being charged reaches 40.0 ± 0.5 vdc measured at the battery terminals.

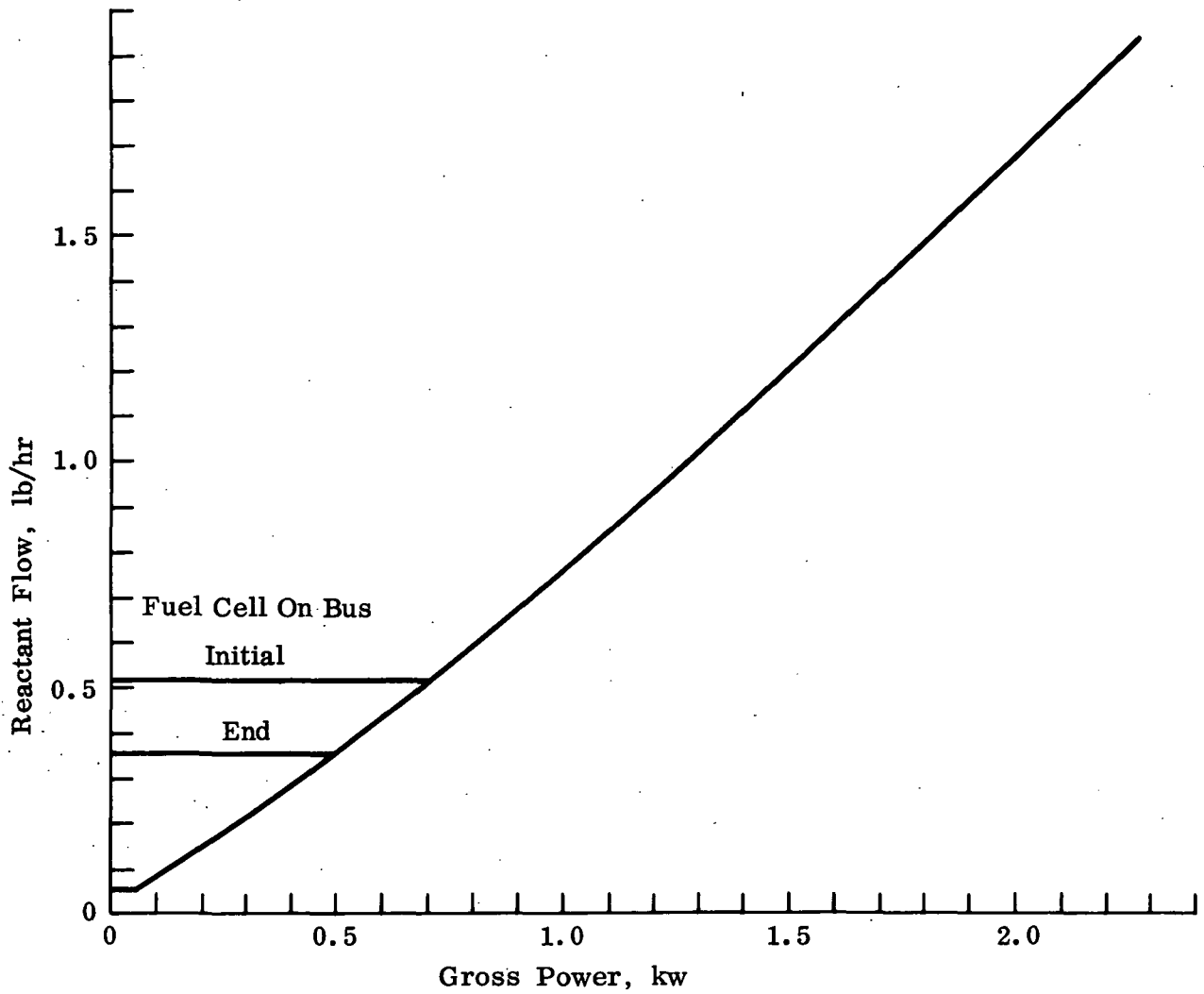

Fig. 13 Fuel Cell Reactant Flow vs Gross Power

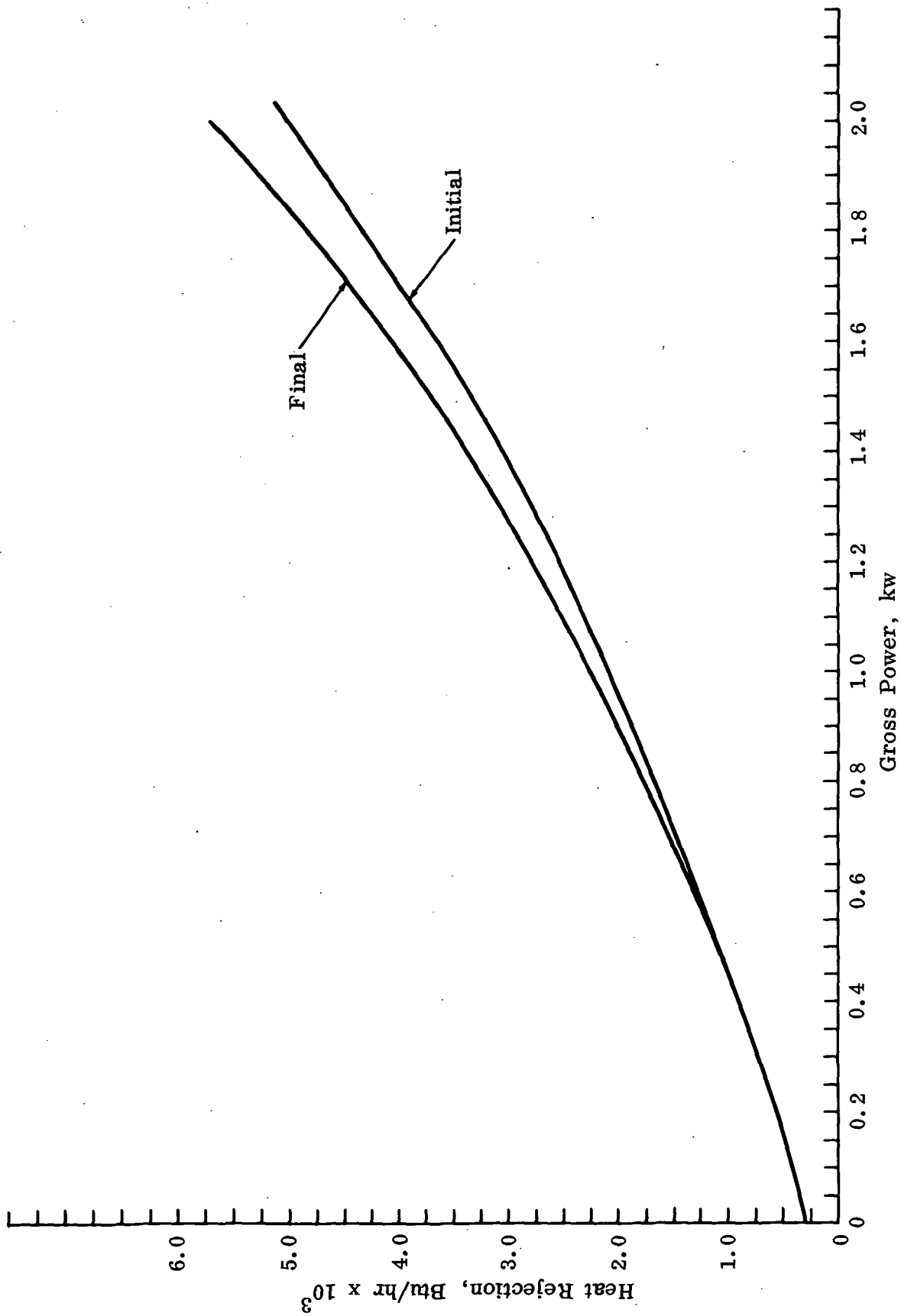

Fig. 14 Fuel Cell Heat Rejection Rate vs Gross Power

SPECIFICATION NO. ESP 13-0100

3.4.2.2.8 Reactant Storage and Supply Section. - The Reactant Storage and Supply Section shall supply the oxygen and hydrogen required for FCA operation and the oxygen required for PLSS recharge. The section shall consist of the following:

- (a) Two high pressure hydrogen storage tanks to supply the FCA.
- (b) One high pressure oxygen storage tank to supply the FCA.
- (c) One high pressure oxygen storage tank to recharge the PLSS.
- (d) Associated plumbing including an interconnecting line between the FCA oxygen storage tank and the PLSS supply oxygen storage tank.

3.4.2.2.9 Radiator. - The FCA waste heat shall be expelled to the external environment by means of the radiator. The radiator shall be an integral part of the coolant loop.

SPECIFICATION NO. ESP 13-0100

3.4.3 Guidance, Navigation, and Control Subsystem. -

3.4.3.1 Primary Guidance, Navigation and Control Subsystem (PGNCS). -

3.4.3.1.1 General Description. - The PGNCS shall be an aided inertial subsystem utilizing radar and optical sensor data to provide vehicle guidance, navigation, control, and status reporting. The subsystem shall have the capability for fully automatic and manual operations.

3.4.3.1.2 Subsystem Sections. - The PGNCS shall consist of the following sections:

- (a) Government Furnished Equipment (GFE) Section
- (b) Transponder Section (TP)
- (c) Landing Radar Section (LR)

3.4.3.1.2.1 GFE Section. - The GFE Section consists of the following:

- (a) Inertial Measurement Unit (IMU) - The IMU shall include inertial sensing gyros mounted on a three gimballed platform which is maintained fixed in inertial space. The IMU shall also include acceleration sensors used to measure vehicle acceleration along the platform axes.
- (b) Power and Servo Assembly/Signal Conditioning Assembly (PSA/SCA) -
 - (1) The PSA, in conjunction with the PTA, shall provide the power supplies, amplifiers, demodulators and calibration circuitry required for the IMU, LGC, CDU's and DSKY.
 - (2) The SCA, in conjunction with the PTA, shall provide the required conditioning circuitry for signal interfacing with telemetry, displays, and other subsystems.
- (c) Pulse Torquing Assembly (PTA) - The PTA shall contain the circuitry required to support the IMU sensor torquing requirements. The PTA shall be located close to the IMU to reduce the effects of cable loading.

SPECIFICATION NO. ESP 13-0100

3.4.3.1.2.1 (Continued)

- (d) Coupling Data Unit (CDU) - The CDU shall transfer angular data between the IMU, LORS, and LGC. Functions of the CDU shall include analog-to-digital and digital-to-analog conversion.
- (e) LEM Guidance Computer (LGC) - The LGC is the central data processing equipment and is a binary, fixed point digital computer with a fixed-rope core memory and an erasable ferrite core memory. Primary inputs to the LGC are received from the inertial equipment, LORS, radar equipment, and from the crew via DSKY and hand-controllers. The LGC processes this information and furnishes primary outputs in the form of attitude and thrusting command signals to the Stabilization and Control Subsystem's Control Electronic Section and data signals to the DSKY and Displays and Controls Subsystem.
- (f) Computer Display and Keyboard (DSKY) and additional displays and controls -
- (1) The DSKY required for the crewman to manually enter data into the LGC.
 - (2) Controls and displays required for operation of the LORS.
 - (3) Displays and controls required for other GFE equipment are an integral part of the Shelter Displays and Control Subsystem.
- (g) LEM Optical Rendezvous System (LORS)
- (h) Navigation Base (NVB)
- (i) Cable Harness

3.4.3.1.2.2 Transponder Section (TP). - The TP shall consist of an electronics assembly and an antenna assembly which operates in the X-Band frequency region. The TP section shall be mounted on the Shelter and shall be capable of being coherently tracked by the Taxi Rendezvous Radar.

SPECIFICATION NO. ESP 13-0100

3.4.3.1.2.3 Landing Radar Section (LR). - The LR shall be an X-Band doppler velocity sensor and altimeter and shall consist of an electronics assembly, antenna assembly and control assembly. The antenna shall be capable of being positioned with respect to the Shelter body axes to maximize LR accuracy. The LR outputs shall be ranged along the altitude beam and velocity data in antenna coordinates.

3.4.3.1.3 PGNCS General Functional Requirements. - The PGNCS shall provide automatically the functions necessary for performance of the navigation, guidance and control tasks for an unmanned lunar landing mission. The detailed mission related functional requirements are outlined below.

3.4.3.1.3.1 PGNCS Navigation Function Requirements. - The navigation function of the PGNCS shall be to produce (to suitable accuracy), the Shelter position, velocity, acceleration, attitude, and timing information necessary for guidance of the Shelter and the monitoring of this guidance. The PGNCS shall transmit this navigational information from both internal and external sources to the LGC for determination of guidance commands and to the DSKY. The PGNCS shall be capable of aligning to a common inertial attitude reference system with that of the PGNCS on the CSM. The navigation functions of the internal sections of the PGNCS are as follows:

- (a) IMU Assembly - The IMU is an inertial sensing assembly which establishes spacecraft attitude in inertial space and determines accelerations along the inertial axes to be used in computing the navigation parameters.
- (b) LR Section - The LR shall provide sensor data relative to the lunar surface in the form of range along the altitude beam and velocity in antenna reference orthogonal coordinates to the LGC.
- (c) LGC Assembly - The LGC processes sensor information to obtain Shelter position, velocity, acceleration, attitude, and timing information for:
 - (1) Guidance and control command computation
 - (2) Telemetry to earth
 - (3) Automatic IMU re-alignment prior to powered descent
 - (4) Sequencing for system de-activation in conjunction with the CES

SPECIFICATION NO. ESP 13-0100

3.4.3.1.3.1 (Continued)

(d) DSKY Assembly - The DSKY shall accept navigational data inserted by a crewman and shall display sensor data and navigational information obtained by processing sensor data in the LGC for guidance initialization.

(e) LEM Optical Rendezvous System - TBD

3.4.3.1.3.2 PGNCS Guidance Functional Requirements. -

3.4.3.1.3.2.1 Mission Related Requirements. - The GFE PGNCS shall provide guidance functions to satisfy the following mission related requirements:

- (a) Separation from the CSM in lunar orbit and orientation for subsequent phases
- (b) Insertion into the required coasting descent transfer orbit that will cause the Shelter to arrive at a predetermined pericyynthion altitude and lunar central angle from the pre-selected lunar landing site
- (c) Powered descent maneuver to specified landing site within required mission constraints
- (d) Inject the space vehicle (CSM with Shelter attached) into a transearth trajectory that will achieve a safe atmospheric entry corridor in event of a Service Module Propulsion Subsystem failure

3.4.3.1.3.3 PGNCS Control Functional Requirements. - To execute the necessary guidance of the Shelter, the PGNCS shall provide for vehicle stabilization and control when operating in conjunction with the SCS in both automatic and attitude hold modes. The characteristics of the control signals provided to the SCS shall be such as to permit spacecraft attitude control with adequate performance characteristics during either coastings or powered flight under either automatic or manual control modes. In the attitude hold mode, the PGNCS shall accept and execute manual rotation command signals from the Flight Crew Control. Attitude control shall be provided by individual RCS thruster commands and descent engine trim commands. In addition, the PGNCS shall provide descent engine throttling, and engine ON-OFF commands. Detailed functional requirements for the Automatic and Attitude Hold modes are given below.

SPECIFICATION NO. ESP 13-0100

3.4.3.1.3.3 (Continued)

(a) Automatic Mode -

- (1) Attitude Control - During thrusting phases, the PGNCSS shall provide automatic command signals to the SCS to control thrust vector direction by commanding vehicle attitude changes. These control signals shall be in the form of RCS thruster commands and Descent Engine trim gimbal commands.
- (2) RCS Translation Control:- Automatic translation command capability shall be provided by the LGC along all three axes. Translation along the X-axis shall be performed utilizing the two available thrusters.
- (3) Descent Engine Throttling - The LGC shall provide the SCS with automatic throttling signals representing positive and negative incremental changes in thrust. The incremental commands are summed and converted in the SCS to a form representing an automatic component of total thrust command.
- (4) Engine ON-OFF Commands:- The LGC shall provide engine ON-OFF commands at the beginning and end of all powered phases except lunar touchdown. At lunar touchdown, the Descent Engine is shut off as a function of external touchdown sensors. The engine ON-OFF signals are directed to the SCS where they are processed and sent to the descent engine. In providing the thruster ON and OFF signals the LGC shall provide for the ullage required for inflight thrusting and account for the effects of tailoff at shutdown.

(b) Attitude Hold Mode:-

- (1) Attitude Control - Capability shall be provided to accept crew commands of vehicle attitude rates proportional to attitude controller displacement. When the controller is returned to the detent position, the vehicle attitude shall be maintained at the attitude existing at the time attitude rate reduces below a specified threshold. When large

SPECIFICATION NO. ESP 13-0100

3.4.3.1.3.3 (Continued)

(b) (1) (Continued)

attitude changes are required, a control couple shall be automatically commanded about the affected axis. The PGNCs shall provide the command signals to the SCS to perform the maneuvers and maintain the changed attitude. These command signals shall be the same form as that specified for the Automatic mode.

- (2) The PGNCs shall identify the flight periods when attitude control will be provided within the fine deadband.

3.4.3.1.3.4 Other Functional Requirements. -

- (a) Displays - Total attitude and attitude error signals will be supplied by the GFE Section for initial alignment.

The GFE Section shall provide via the DSKY a display of status, navigation and guidance data. The latter shall be displayed automatically or at the command of the flight crew via the keyboard. The DSKY shall, as a minimum, also be capable of permitting the flight crew to initiate the LGC programs for the mission, perform in-flight checkout, and insert updated navigation data.

- (b) Controls - The GFE Section shall have the capability to permit the flight crew to transfer star position information from the LORS to the LGC.

The GFE Section shall provide the required temperature control for the IMU for ground testing and all mission phases.

- (c) GFE/Radar Functional Requirements - The GFE Section shall provide the signals required to command and control the transfer of radar output information from the LR to the LGC. As required, the GFE Section will provide the additional smoothing time required on radar output signals to meet accuracy requirements.

SPECIFICATION NO. _____ ESP 13-0100

3.4.3.1.3.4 (Continued)

(c) (Continued)

The LGC shall have the capability to automatically position the LR antenna at those points in the mission phase when LR data accuracy is optimized by changing antenna position with respect to the vehicle.

(d) LEM Optical Rendezvous System - TBD3.4.3.1.3.5 Functional Requirements for the Radar Sections. -

3.4.3.1.3.5.1 Transponder Functional Requirements. - The transponder shall receive the signal from the Taxi Rendezvous Radar, and re-transmit a coherent signal at a frequency offset from the Taxi RR transmitted frequency. A beacon mode of operation shall be provided to assist in acquiring the transponder signal.

3.4.3.1.3.5.2 Landing Radar Functional Requirements. - The landing radar shall furnish the following information in the appropriate form for use by the PGNCs as a primary function:

- (a) Range along the altitude beam
- (b) Doppler velocity in an antenna referenced orthogonal coordinate system

3.4.3.1.4 PGNCs Operating Modes. -

3.4.3.1.4.1 GFE Section Operating Modes. - The GFE Section of the PGNCs will have two primary operating modes (Automatic and Manual) and three secondary operating modes (Alignment, IMU Temperature Control and LGC control).

3.4.3.1.4.1.1 Automatic Mode. - In the automatic mode, the PGNCs will generate and issue all required commands to effect thrust vector control and vehicle stabilization and control as defined in 3.4.3.1.3.3.

SPECIFICATION NO. ESP 13-0100

3.4.3.1.4.1.2 Manual Mode. - In the manual mode the PGNCs shall execute Shelter/CSM vehicle rotation commands as directed by the crew via the hand controller. These crew commands will establish one of the control modes described in 3.4.3.1.3.3.

3.4.3.1.4.1.3 Alignment Mode. - In the alignment mode the GFE section will align the stable member of the IMU using inputs from the LORS to initiate the following phases of this mode:

- (a) Zero Mode - The zero mode shall set the gimbal angle registers in the CDU and the LGC to zero. These gimbal angle registers shall accept gimbal angle information in the incremental format.
- (b) Coarse Align - The coarse align mode shall be used for the initial coarse alignment of the IMU. The stable member of the IMU shall be coarse aligned by torquing the gimbal torquers with CDU error signals derived from LGC specified gimbal angles.
- (c) Fine Align - The IMU stable member shall be positioned in the fine align mode to the required inertial orientation. The LGC transforms star line of sight information into the required inertial reference frame. The difference between the required and the existing course aligned reference frame shall be used to compute the necessary gyro torquing signals to position the stable member to the desired orientation.

3.4.3.1.4.1.4 IMU Temperature Control Mode. - There will be one temperature control mode for the IMU which will be completely automatic and remain in operation once power is applied through an IMU standby switch closure. The temperature control system will consist of three integrated circuits as follows:

- (a) Temperature Control Circuit
- (b) Temperature Alarm Circuit
- (c) Blower Control Circuit

Provisions shall be incorporated for external temperature control of the IMU during shipping, transportation, and shelf time.

3.4.3.1.4.1.5 LEM Guidance Computer Control Modes. - The LGC will have the following operating modes:

SPECIFICATION NO. ESP 13-0100

3.4.3.1.4.1.5 (Continued)

- (a) Power Off
- (b) Standby (LGC clock on)
- (c) Power On

Once the LGC is initialized, the power is not turned off, but the standby mode is used for retention of stored data.

3.4.3.1.4.2 Radar Operating Modes. -

3.4.3.1.4.2.1 Transponder Operating Modes. - The transponder operates in the following two modes:

- (a) Beacon - The transponder provides a signal to assist Taxi RR acquisition in this mode.
- (b) Transponder - In this mode the transponder receives the signal from the Taxi RR and transmits a coherent signal that is frequency offset from the Taxi RR transmitted frequency.

3.4.3.1.4.2.2 Landing Radar Operating Mode. - The Landing Radar has a single automatic mode of operation.

3.4.3.1.5 PGNCS Performance Requirements. - The PGNCS performance shall be such that when operating with all interfacing subsystems, within mutually imposed constraints, specified functional requirements of the PGNCS are met. In all phases of the mission, the PGNCS shall not provide commands resulting in transients beyond the tolerance of any of the following: the crew, structure, and subsystems (equipment).

3.4.3.1.5.1 GFE Section Performance Requirements. - The contribution of GFE PGNCS guidance mechanization and execution errors to differences in ΔV from the idealized minimum value shall be so limited that the overall shelter system accuracy in performing the Shelter mission is achieved within the total ΔV budget which will be specified at a later date. However, the total ΔV budget specified in Grumman Specification LSP-470-1A essentially represents this requirement and should be used as a reference. The GFE PGNCS detailed performance requirements shall be as specified in the LEM PGNCS Performance and Interface Specification.

3.4.3.1.5.2 GFE Section Stabilization and Control Performance Requirements. - Performance requirements are defined in the LEM GFE PGNCS Performance and Interface Specification.

SPECIFICATION NO. _____ ESP 13-0100

3.4.3.1.5.3 Radar Section Performance Requirements. - The TP and LR sections performance requirements will be specified at a later date; however, Grumman Specification LSP-370-2A, Section 3 essentially represents these requirements and should be used as a reference.

3.4.3.1.6 PGNCS Interfaces. - The PGNCS shall interface with the following:

- (a) Stabilization and Control Subsystem (SCS) - The PGNCS shall interface with the SCS to perform the following functions:
- (1) Out of Detent - Signals from the Attitude Controller Stick to tell the LGC that the Attitude Controller is not in the neutral position.
 - (2) Translation Command (X Axis) - Command translation by ON-OFF firing of the RCS jets by means of the LGC.
 - (3) Translation Command (Y Axis) - Command translation by ON-OFF firing of the RCS jets by means of the LGC.
 - (4) Translation Command (Z Axis) - Command translation by ON-OFF firing of the RCS jets by means of the LGC.
 - (5) Engine On Command - Initiate engine start sequence.
 - (6) Engine Off Command - Initiate engine stop sequence.
 - (7) Increase Throttle - Signal from the LGC to command the thrust to increase.
 - (8) Decrease Throttle - Signal from the LGC to command the thrust to decrease.
 - (9) + Pitch Gimbal Trim Commands - Signal from LGC to CES to position DE Pitch Gimbal.
 - (10) + Roll Gimbal Trim Commands - Signal from LGC to CES to position DE Roll Gimbal.
 - (11) RCS Jet On Commands (8) - Command signals from LGC to the jet driver preamps in the CES.

SPECIFICATION NO. ESP 13-0100

3.4.3.1.6 (Continued)

(a) (Continued)

- (12) Proportional Rate Commands (Pitch, Roll, Yaw) - Attitude signals from Attitude Controller.
- (13) Pitch or Roll Gimbal OFF - Signals to inform LGC of descent engine pitch or roll gimbal failure.
- (14) PGNCS - OFF - Signal to shut down the PGNCS after post landing checkout.

(b) Instrumentation Subsystem (IS) - The PGNCS interface with the IS is as follows:

- (1) Synch. (1024 KPPS) - Synchronize LEM master timing equipment with LGC.
- (2) Serial Digital Data - Digital data from LGC for downlink.
- (3) Stop Pulse - Signal to indicate end of LGC downlink word transmission.
- (4) Start Pulse - Signal to indicate start of LGC downlink word transmission.
- (5) Bit Synch. Pulses - Synchronized serial bits transmitted through downlink between start and end pulses.
- (6) Discrete PGNCS Subsystem Status Data - PGNCS Caution and Warning signals to Instrumentation for Control Panel Display and Telemetry.
- (7) Analog PGNCS Subsystem Status Data - Analog data to the IS for telemetry.

(c) Ascent Stage Structure - The PGNCS shall interface with the ascent structure to provide the required physical bonding and alignment for the IMU, PTA and LORS.

SPECIFICATION NO. ESP 13-0100

3.4.3.1.6 (Continued)

- (d) Descent Stage Structure - The PGNCS shall interface with the descent stage structure to provide the physical bonding and alignment for the LR antenna.
- (e) Electrical Power Subsystem (EPS) - The PGNCS shall interface with the EPS to accept the required electrical power for the particular loads incorporated in the PGNCS.
- (f) Ground Support Equipment (GSE) - The PGNCS shall interface with the GSE to exchange intelligence required for ground (Prelaunch) testing.
- (g) Crew Provisions Subsystem (CPS) - The PGNCS shall interface with the Crew Provisions Subsystem to accomplish the following:
 - (1) Installation of the Power Servo Assembly/Signal Conditioning Assembly (PSA/SCA)
 - (2) Installation of the LEM Guidance Computer (LGC)
 - (3) Installation of display and keyboard (DSKY) for LGC.
 - (4) Provide design eye visibility position.

3.4.3.2 Stabilization and Control Subsystem (SCS). - The SCS shall consist of the following:

- (a) The Control Electronics Section (CES) -
 - (1) ATCA Attitude Translation Control Assembly
 - (2) DECA Descent Engine Control Assembly
 - (3) GDA Gimbal Drive Assembly
 - (4) ACA Attitude Controller Assembly
 - (5) PCA Program Coupler Assembly
 - (6) XYSA X-Y Scanner Assembly

SPECIFICATION N.O. ESP 13-0100

3.4.3.2 (Continued)

- (b) The SCS shall be operational in the primary guidance and control path.

3.4.3.2.1 CES Functional Requirements. - The CES shall provide:

- (a) Signal processing, generation and switching as required to complete the control path in conjunction with PGNCs.
- (b) Functions required for Shelter shutdown, monitoring and reactivation on the Lunar surface.
- (c) Search capability to acquire or reacquire the earth transmitter signals to the S-band antenna.

3.4.3.2.2 CES Functions for the Control Path. - When operating as part of the control path in conjunction with the PGNCs, the CES shall provide for implementation of the control signals originating from the LGC as specified below to accomplish attitude and translation control of the vehicle. The CES shall provide the necessary control signals as specified below.

- (a) Reaction Jet Firing - The CES will accept from the LGC discrete ON-OFF thrust command signals for each of the eight reaction control jets and convert them to the required electrical power signals to operate the RCS jet solenoid valves.
- (b) Descent Engine Gimbaling - The CES will accept from the LGC discrete ON-OFF rotation command signals and will provide the implementation necessary to effect angular rotation of the descent engine about its two orthogonal gimbal axes. Upon receipt of the ON command signal, the descent engine will rotate at a constant angular rate, in the direction and axis commanded, within a limited angular deflection region until receipt of the OFF signal.
- (c) Throttle and ON-OFF Control - The CES shall accept the descent engine ON-OFF commands from the LGC via the engine sequencer portion of the Displays and Controls Subsystem, and provide them to propulsion to fire or shutdown the descent engine.

SPECIFICATION NO. _____ ESP. 13-0100

3.4.3.2.2 (Continued)

- (d) Thrust Control Mode - During operation of the descent engine, automatic thrust control signals will be used to throttle the engine within 10 to 100 percent normalized range of operation. The engine throttle command signals from the PGNCs will be processed in the CES and directed to the descent engine.
- (e) Displays and Control - The LGC shall receive detent and attitude control signals from the Attitude Controller Assembly in the CES.

3.4.3.2.3 CES Assemblies. - The individual CES assemblies shall have the following characteristics and performance capabilities:

- (a) Attitude and Translation Control Assembly (ATCA) - The ATCA shall consist of the electronics necessary to generate power supply voltages required by the DECA, RGA, and Controllers in addition to those functions specified in 3.4.3.2.1(a).
- (b) Descent Engine Control Assembly (DECA) - The DECA shall consist of the electronics necessary to perform the following functions:
- (1) Process LGC throttle commands to the throttle control electronics of the Descent Engine.
 - (2) Process Gimbal Trim Commands from LGC to the GDA's
 - (3) Process engine ON-OFF commands
 - (4) Provide GDA failure detecting circuitry
 - (5) Provide power control circuitry for the GDA's
- (c) Gimbal Drive Actuator (GDA) - The GDA shall be a slow speed electromechanical device, containing a 400 cps brushless A-C motor driving a screw jack. The screw jack shall be irreversible under full load and shall require an electrical signal to rotate the gimbal in either direction. On command from DECA the GDA's shall trim the Descent Engine so that the thrust vector rotates about the pitch and roll axes. Two GDA's shall be provided, one for each of the pitch and roll gimbals.

SPECIFICATION NO. ESP 13-0100

3.4.3.2.3 (Continued)

- (d) Attitude Controller Assembly (ACA) - The attitude controller shall contain a position transducer, detent switches, direct mode switches and limit switches in each of the three axes and shall provide:
- (1) Proportional rate commands in the attitude hold mode to the LGC.
 - (2) Two jet direct commands
 - (3) Out of detent signals to command the LGC to go into an attitude follow-up mode
- (e) Program Coupler Assembly (PCA) - The PCA shall be an electro-mechanical device that conditions and couples commands originating in the LGC or Digital Command Assembly (DCA) to provide the functions of 3.4.3.2.1(b).
- (f) X-Y Scanner Assembly (XYSA) - The XYSA shall consist of the electronics necessary to perform the functions of 3.4.3.2.1(c).

3.4.3.2.4 External Interfaces. - The CES shall interface with the following subsystems or equipment:

- (a) Electrical Power Subsystem (EPS) - The CES shall accept the electrical power required for operation from the EPS.
- (b) Primary Guidance and Navigation Subsystem (PGNCS) - The CES shall accept input signals from the PGNCS to provide the following:
- (1) ON-OFF commands for each of the eight Reaction Control Jets.
 - (2) ON-OFF commands to the Descent engine
 - (3) Descent engine trim gimbal commands
 - (4) Thrust magnitude commands to the descent engine
 - (5) 800 Cycle power to excite the controller

SPECIFICATION NO. ESP 13-0100

3.4.3.2.4 (Continued)

- (c) The CES shall feed signals to the LGC to provide the following in the PGNCS primary mode:
- (1) Proportional attitude rate commands
 - (2) Gimbal fail signals
 - (3) Attitude controller out of detent
- (d) Reaction Control Subsystem (RCS) - The CES shall provide the signals to actuate the RCS jet solenoids.
- (e) Descent Engine (DE) - The CES shall provide the command signals to the DE to accomplish the following:
- (1) Ignition and shutdown of the Descent engine.
 - (2) Automatic throttling of the Descent engine
- (f) Displays and Controls Subsystem (D&C) - The CES shall provide inputs to the appropriate controls and displays to enable control and monitoring of the SCS for initial alignment.
- (g) Instrumentation Subsystem (IS) - The CES shall provide output signals to the IS for inflight monitoring.
- (h) Environmental Control Subsystem (ECS) - The ECS shall provide mounting surfaces and thermal protection for the CES equipment.
- (i) Structural Design Subsystem - The Structural Design Subsystem shall provide the area and mounting accommodations to house the CES equipment within the structure.
- (j) Communication Subsystem - The Communication Subsystem shall provide the necessary signals from ground commands via the DCA to activate and control the PCA.

SPECIFICATION NO. ESP 13-0100

3.4.4 Reaction Control and Propulsion Subsystem. - The Reaction Control and Propulsion Subsystem shall consist of the following:

- (a) Reaction Control Subsystem (RCS) consisting of:
- (1) Helium pressurization section
 - (2) Positive expulsion propellant supply and distribution section
 - (3) Eight reaction control rocket engines
 - (4) A propellant quantity gauging section
 - (5) A pressure venting system for depressurizing the pressurization and propellant tanks after lunar landing
- (b) Descent Propulsion Subsystem consisting of:
- (1) Engine Section
 - (2) Propellant Feed Section
 - (3) Pressurization Section
 - (4) A pressure venting system for depressurizing the pressurization and propellant tanks after lunar landing

3.4.4.1 Performance. -

3.4.4.1.1 Reaction Control Subsystem. - The Reaction Control Subsystem (RCS) shall provide the impulse for either three axis rotational or translational control of the shelter during all flight mission phases and shall operate in a zero gravity environment. The attitude and translational control functions shall include but not be limited to:

- (a) Translation for separation from the Command Service Module (CSM)
- (b) Ullage settling of the propulsion subsystem propellants

SPECIFICATION NO. ESP 13-0100

3.4.4.1.1.1 The RCS rocket engine shall have the following performance characteristics:

- (a) Thrust - The rocket engine shall develop a continuous operation vacuum thrust of 100 ± 5 lbs.
- (b) Thrust Transient Rate - The rocket engine shall demonstrate a thrust buildup and thrust decay as shown in Figure 15
- (c) Specific Impulse - When operating engines for periods in excess of one second the specific impulse shall be 294 seconds nominal. Specific impulse for pulse mode operation shall be as shown in Figure 16
- (d) Minimum Impulse - An electrical signal (pulse width) of 12.5 milliseconds shall provide the engine with a minimum impulse of 0.4 ± 0.2 pound seconds during vacuum operation
- (e) Reliable Operating Life - Following acceptance tests, the engine shall have a minimum reliable life of 1000 seconds. The engine shall withstand a minimum of 10,000 operational cycles during the 1000 second operating life without deterioration. The engine shall be capable of continuous operation for a period of 500 seconds.

3.4.4.1.1.2 Propellant Section Performance. - The propellant section shall provide storage and supply for the oxidizer and fuel. The oxidizer and fuel equipment are identical except for the volume of the supply tanks. The propellant shall be furnished to the engine for steady state operation at a dynamic pressure of 170 ± 10 psia.

3.4.4.1.1.3 Propellant Quantity Gaging Section. - The Propellant Quantity Gaging Section shall determine the quantity of propellant in the positive expulsion tanks and provide a warning of imminent propellant depletion via telemetry equipment. The Propellant Quantity Gaging equipment shall perform even while the vehicle is exposed to a zero gravity environment.

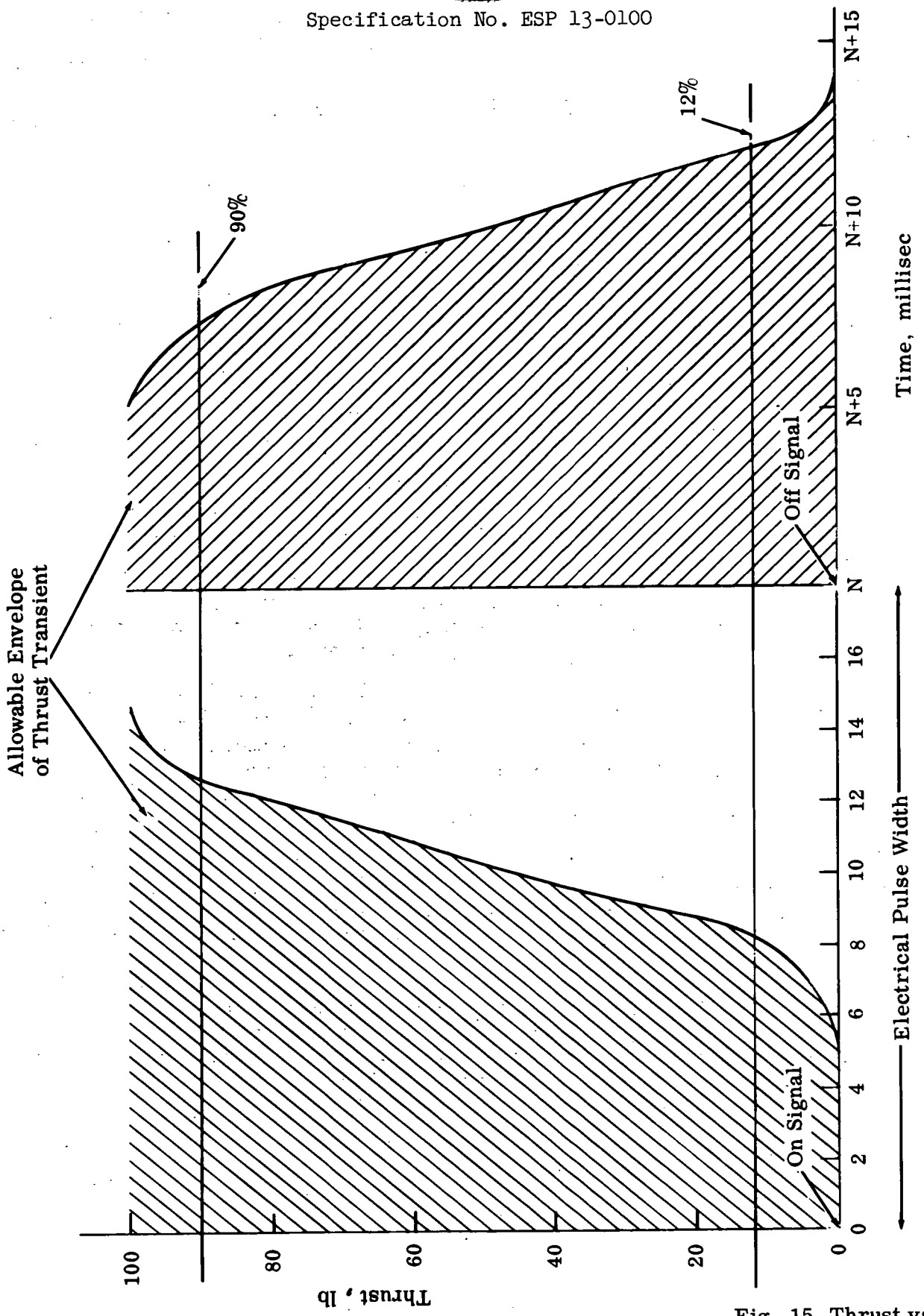

Fig. 15 Thrust vs Time

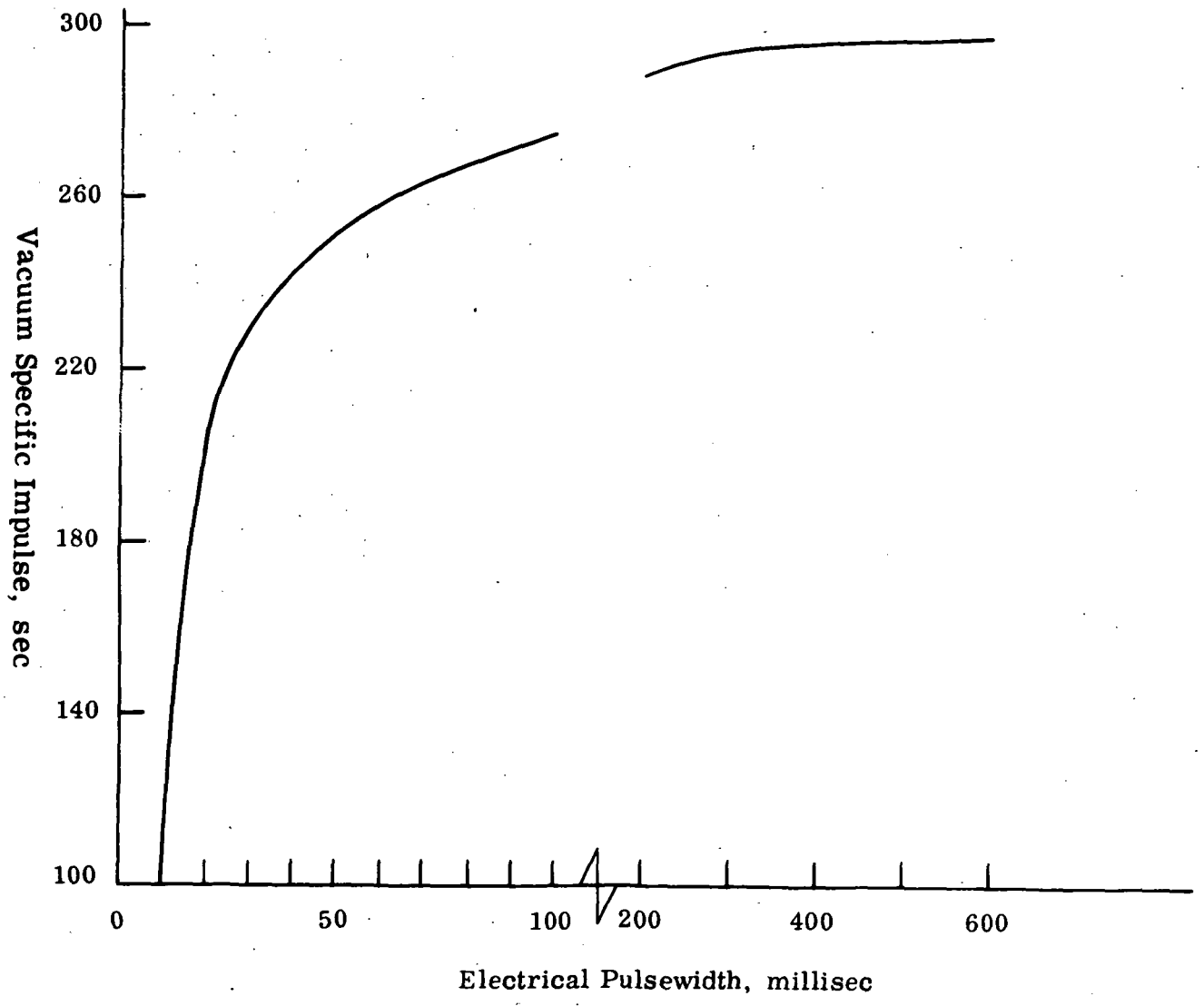

Fig. 16 Vacuum Specific Impulse vs Electrical Pulse Width

~~CONFIDENTIAL~~SPECIFICATION NO. ESP 13-0100

3.4.4.1.1.4 Pressurization Section. - The Pressurization Section shall distribute helium at regulated pressure to the propellant tanks for positive expulsion of propellant through the assembly components and tubing. Pressure regulation shall be accomplished by a parallel series regulator arrangement. The helium supply pressure shall be reduced to the normal dynamic operating pressure of approximately 181 psia.

3.4.4.1.1.5 Pressure Venting Section. - Upon command from Earth, pressure shall be vented from the pressurization and propellant tanks after lunar landing.

3.4.4.1.2 Descent Propulsion Subsystem (DPS). -

- (a) The propulsion subsystem shall supply the impulse for the following modes:
- (1) Normal - All major velocity increments required for insertion into descent transfer orbit and powered descent including initial deboost, landing approach, hover and touchdown.
 - (2) Abort - Backup of SPS within the limits of the propulsion subsystem ΔV capability.
- (b) Thermal control of subsystem components shall be by passive means.

3.4.4.1.2.1 Descent Engine. - The descent engine shall have the following characteristics:

- (a) Thrust - Throttleable over a 10:1 range from 10,500 pounds to 1,050 pounds, nominal in a vacuum.
- (b) Specific Impulse - $I_{sp} = 305$ minimum 3-sigma value at maximum thrust following 857 seconds of operation for the nominal duty cycle shown in Figure 17. $I_{sp} = 285$ minimum 3-sigma value at minimum thrust following 857 seconds of operation for the nominal duty cycle shown in Figure 17.

~~CONFIDENTIAL~~

SPECIFICATION NO. ESP 13-0100

3.4.4.1.2.1 (Continued)

(c) Operating Life - 857 seconds for the nominal duty cycle shown in Figure 17. The engine shall be designed to consume the remainder of 17931 lbs. of propellant following completion of the duty cycle with the throttle set at 25 percent thrust position.

(d) Gimbal Angle - In both Y and Z axes, plus or minus six degrees.

3.4.4.1.2.2 Propellant Section Performance. - The propellant section shall provide storage and supply for the oxidizer and fuel. The oxidizer and fuel equipment are identical with parallel feedout and a propellant distribution assembly. Crossover lines are provided between like tanks for passive propellant management. The propellant shall be furnished to the engine for steady state operation at a dynamic pressure of 210 ± 4 psia.

3.4.4.1.2.3 Propellant Quantity Gaging. - There shall be no provisions for continuous quantity gaging. There shall be sensors provided to warn of imminent propellant depletion via the telemetry equipment.

3.4.4.1.2.4 Pressurization Section. - The Pressurization Section shall distribute supercritical helium at regulated pressure to the propellant tanks for positive expulsion of propellants through the assembly components and tubing. Pressure regulations shall be accomplished by a parallel series regulator arrangement. The supercritical helium supply pressure shall be reduced to the normal dynamic operating pressure of approximately 230 psia. High pressure helium shall be considered as an alternate. The Shelter shall use the same pressurization system as the LEM.

3.4.4.1.2.5 Pressure Venting Section. - Upon command from earth, pressure shall be vented from the pressurization and propellant tanks after lunar landing.

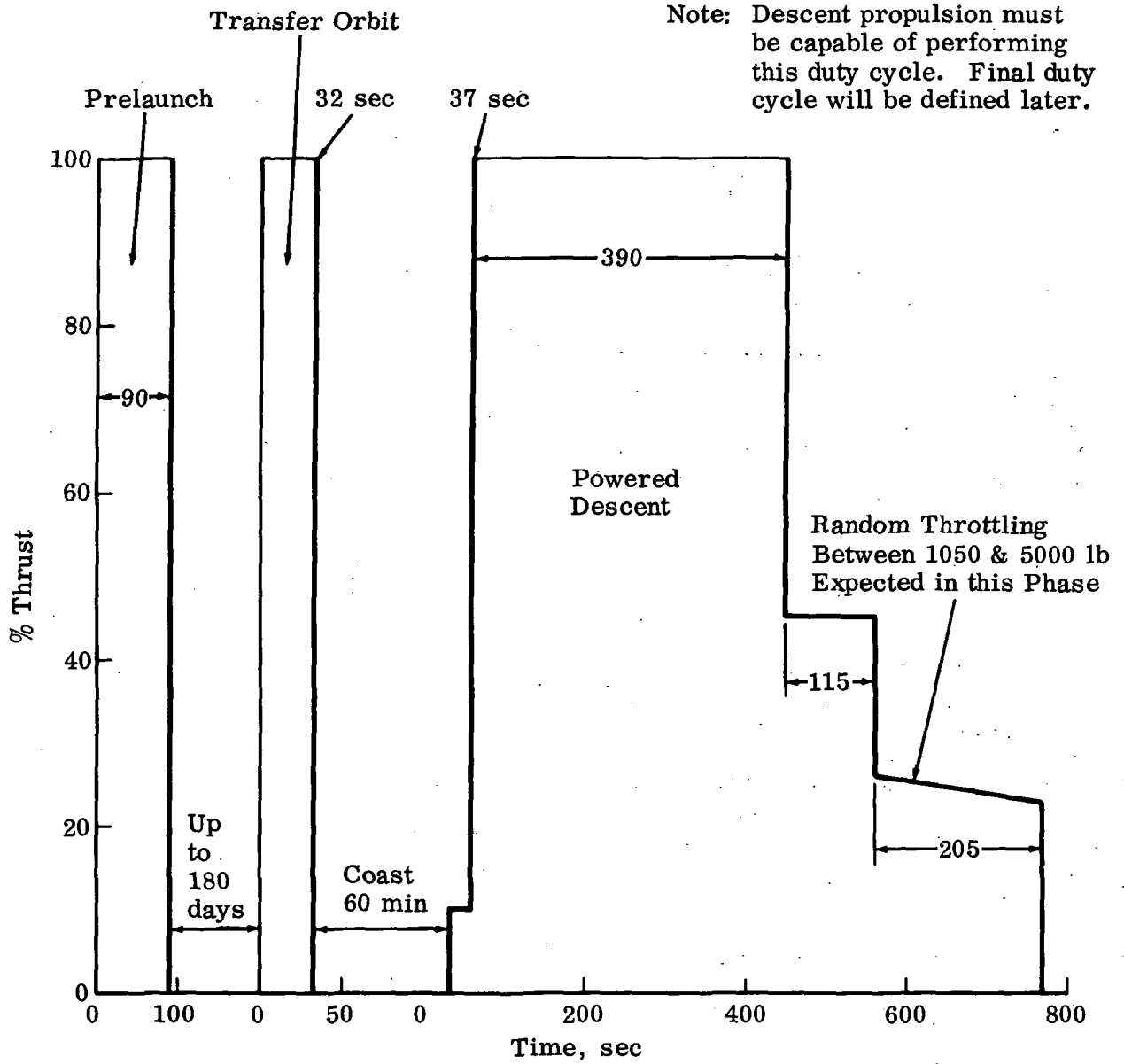

Fig. 17 Descent Propulsion Nominal Mission

SPECIFICATION NO. ESP 13-01003.4.4.2 Design Requirements. -3.4.4.2.1 RCS Design Requirements. -

3.4.4.2.1.1 Rocket Engine. - The rocket engines are mounted in clusters of two as shown in Figure 18. The rocket engine shall be pulse-modulated, pressure-fed, radiation cooled, and shall utilize earth-storable hypergolic propellants.

3.4.4.2.1.2 Propellant Section. - The propellant supply shall consist of nitrogen tetroxide (N_2O_4) oxidizer (per specification MIL-P-26539) and a mixture of 50 percent hydrazine (N_2H_4) and 50 percent unsymmetrical dimethylhydrazine (UDMH) (per specification MIL-P-27402) as fuel. The oxidizer and fuel shall be stored in separate tanks. The tanks shall be cylindrical with hemispherical ends, of titanium alloy. A teflon bladder shall be incorporated between the pressurant and propellant for expulsion. The maximum tank working pressure shall be 248 psia, proof pressure 331 psia, and burst pressure 372 psia.

3.4.4.2.1.3 Propellant Quantity Gaging Section. - The propellant quantity gaging equipment shall be a nucleonic type using cobalt 60 radioisotope source. A signal shall be provided to the master caution-warning panel from the ratio section if the ratio exceeds a preset range. The accuracy of the propellant mass ratio circuit shall be within two percent of total tank capacity of the tankage module. The difference between the actual propellant quantity and the quantity measured shall not exceed one percent of the total tank capacity except tank quantities less than 10 percent and more than 90 percent when one-half percent accuracy is required. Means shall be provided to conduct a complete system ground checkout including failure identification of a replaceable assembly.

3.4.4.2.1.4 Pressurization Section. - The pressurization section shall consist of a high pressure helium supply contained in one spherical, titanium tank and associated pressure regulation and distribution assembly. The tank shall accommodate 1.03 lbs of helium at an initial pressure of 3050 ± 50 psia. the maximum working pressure shall be 3500 psia to accommodate pressure transients. Proof pressure shall be 4650 psia and burst pressure 7000 psia.

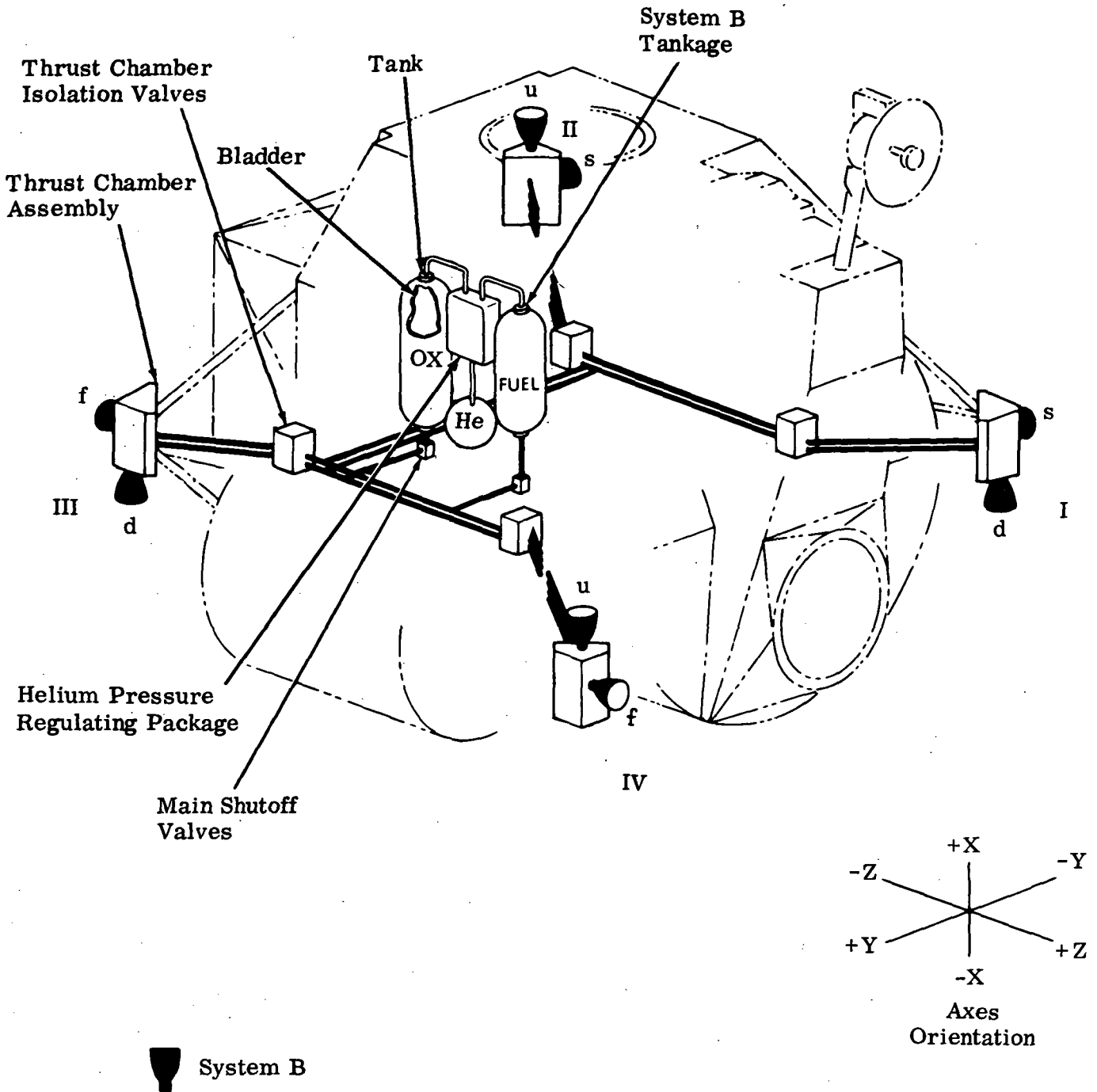

Fig. 18 RCS General Arrangement

SPECIFICATION NO. ESP 13-0100

3.4.4.2.1.5 Pressure Venting System. - Upon command, pressure shall be vented from the pressurization tank and from the propellant tanks.

3.4.4.2.2 Descent Propulsion Subsystem (DPS). -

3.4.4.2.2.1 DPS Design Requirement. -

3.4.4.2.2.2 Engine Section. - The descent engine shall consist of a single unit, pressure-fed variable area injector, throttleable, gimballed, ablation-cooled, bipropellant, hypergolic liquid-fueled rocket engine with a crushable radiation-cooled nozzle skirt. The engine shall have multiple restart capability and be gimbal mounted to permit thrust vector control.

3.4.4.2.2.3 Propellant Section. - The propellant section shall consist of an oxidizer and fuel supply using nitrogen tetroxide (N_2O_4) as the oxidizer (per specification MIL-P-26539) as a mixture of 50 percent hydrazine (N_2H_4) and 50 percent unsymmetrical dimethylhydrazine (UDMH) (per Specification MIL-P-27402) as the fuel, each shall have two cylindrical skirt mounted titanium tanks with parallel feedout and a propellant distribution assembly. Crossover lines are provided between like tanks for passive propellant management. Propellant utilization shall be accomplished with fixed orifices.

3.4.4.2.2.4 Propellant Quantity Gaging. - Continuous quantity gaging shall not be provided. Low level sensors shall be furnished in each tank to provide warning of imminent propellant depletion via telemetry equipment.

3.4.4.2.2.5 Pressurization Section. - The pressurization section shall consist of a supercritically stored helium supply contained in a single, spherical, vacuum-jacketed tank equipped with internal heat exchanger valves, associated external heat exchanger, pressure regulation and distribution assembly. High pressure helium shall be considered as an alternate pressurization system. The Shelter shall use the same pressurization system as the LEM.

3.4.4.2.2.6 Pressure Venting Section. - Upon command from Earth, pressure shall be vented from the pressurization and propellant tanks after lunar landing.

SPECIFICATION NO. ESP-13-0100

3.4.5 Communications Subsystem (CS). - The CS shall consist of the following sections:

- (a) S-band section
- (b) VHF section
- (c) Signal processing assembly
- (d) Up Data Link (Command Decoder)

3.4.5.1 Performance Requirements. - Communications capability shall be provided between the Shelter and the Manned Space Flight Net (MSFN), Command Service Module (CSM) and Extra Vehicular Astronaut (EVA). The communications equipment shall be compatible with the equipments with which it interfaces, as shown in Figure 19.

3.4.5.1.1 Types of Communications. - The following types of communications shall be provided:

- (a) Two way voice and voice conference
- (b) Tracking and ranging aids
- (c) Telemetry transmission
- (d) Key transmission
- (e) Biomedical data transmission
- (f) Up Data Link

Radio frequency utilization shall be as shown in Figure 20.

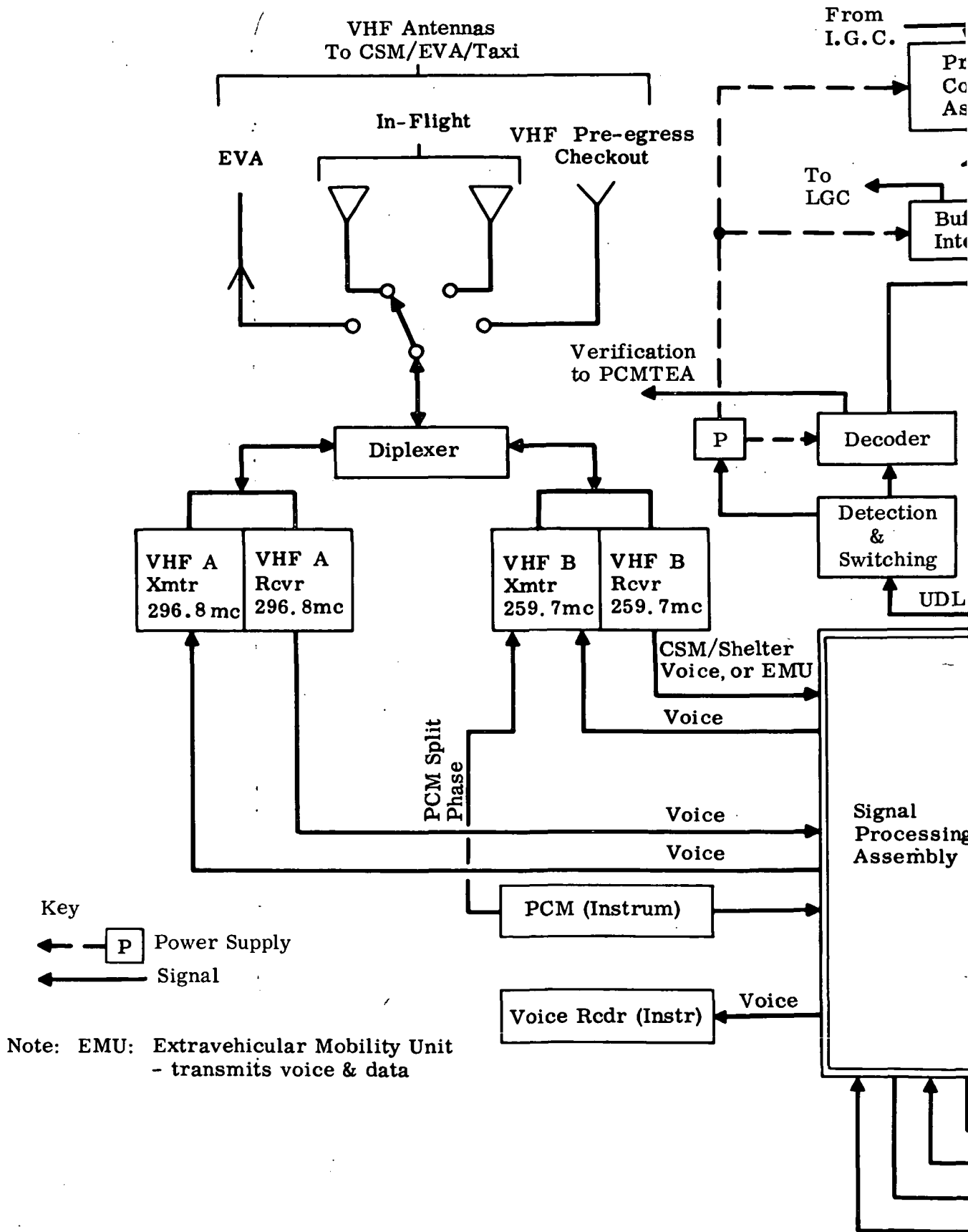

105①

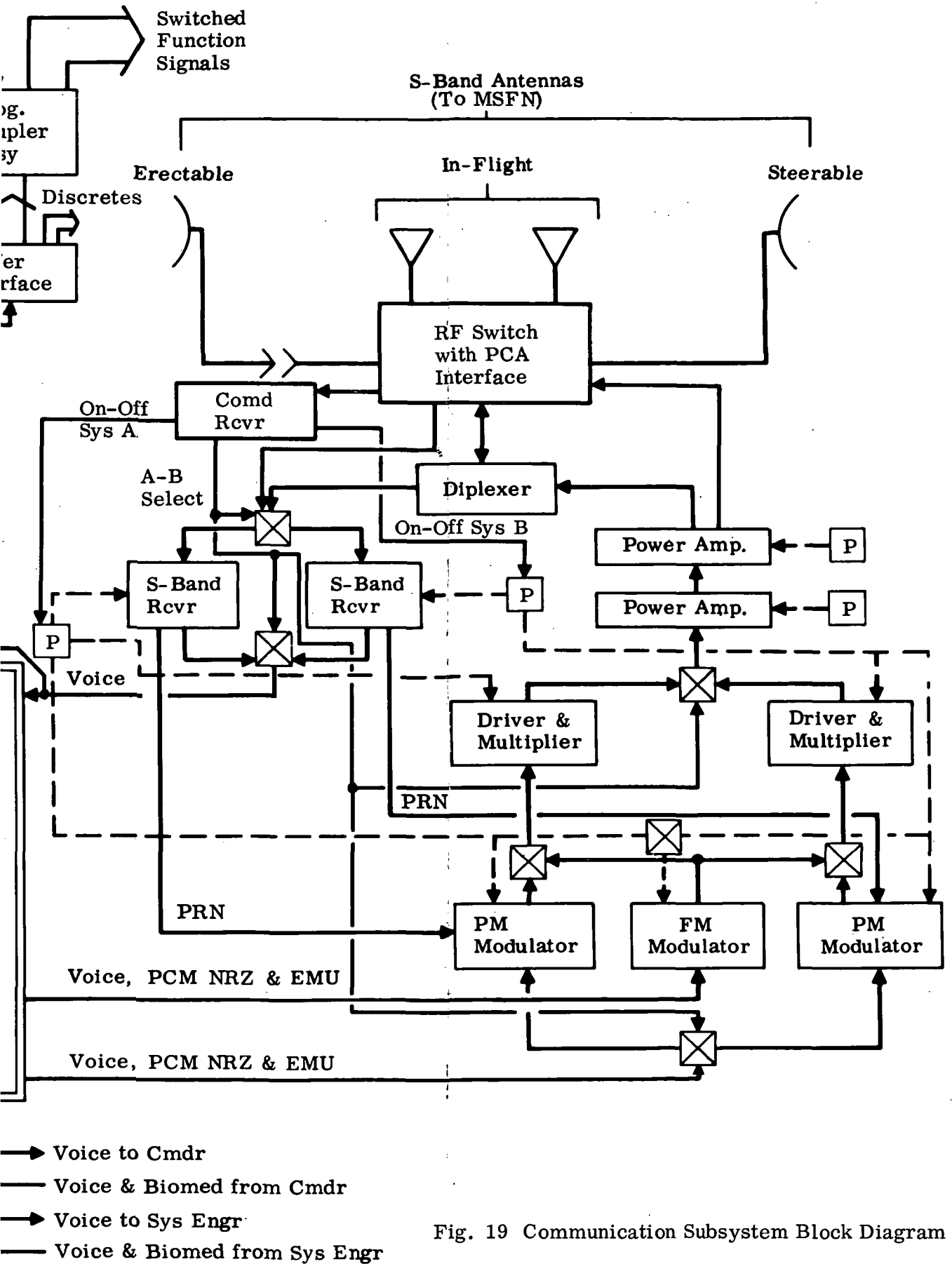
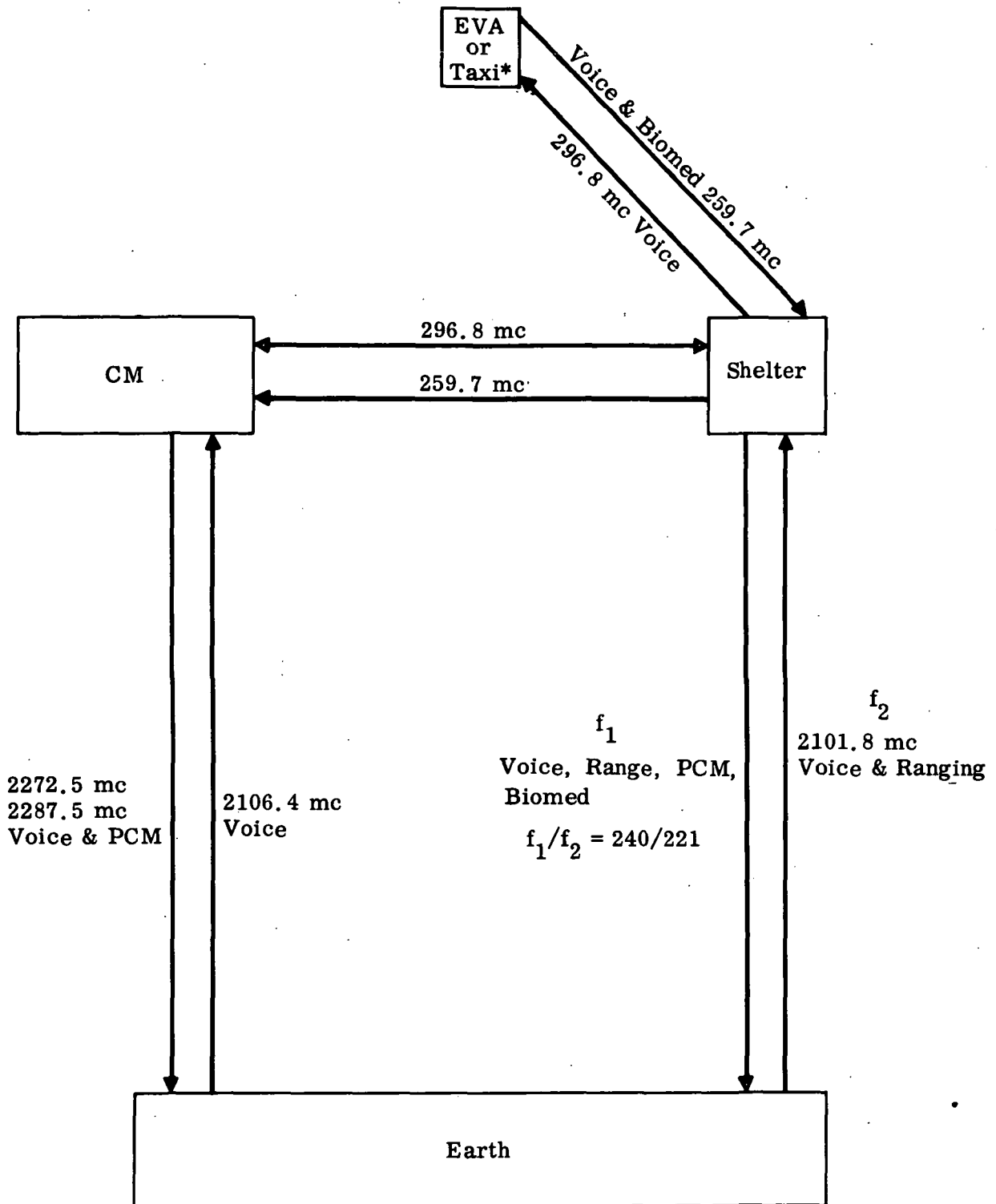

Fig. 19 Communication Subsystem Block Diagram



* Only when Taxi is manned.

Fig. 20 Shelter Communication Links

SPECIFICATION NO. ESP-13-0100

3.4.5.1.2 Two Way Voice Conference. - Two way voice and voice conference shall be available between the following:

- (a) Shelter - MSFN - Duplex voice communications capability between the Shelter and the MSFN to a minimum slant range of 220,000 nautical miles shall be provided by an S-Band communications link. The voice channel shall be so designed as to provide two-way voice capability using the Shelter inflight omni antennas.
- (b) Intercommunications - An intercommunications capability between the crew members inside the Shelter shall be provided.
- (c) Shelter - EVA - Duplex voice communications capability between the crew member inside the Shelter and an EVA within a three nautical mile radius of the Shelter shall be provided by a VHF/AM communications link. Duplex voice communications capability shall exist between the Shelter and an EVA as a backup.
- (d) Shelter - CSM - Simplex voice communications capability between the Shelter and the CSM shall be provided during all inflight line of sight phases of the lunar mission. Range capability inflight shall be 550 nautical miles, minimum.
- (e) MSFN - Shelter - CSM and MSFN - Shelter - EVA Voice Conferences - Voice conference capability between the MSFN, Shelter and CSM or EVA shall be provided by use of the Shelter to relay voice from the CSM or EVA to the MSFN via the Shelter - MSFN Duplex S-Band voice link, and to relay voice from the MSFN to the CSM or EVA via the CSM - Shelter simplex VHF or Shelter - EVA Duplex VHF voice links, respectively. Simultaneous capability for these two modes is not required.

SPECIFICATION NO. ESP-13-0100

3.4.5.1.3 S-Band Tracking and Ranging. - The Shelter shall be equipped to permit the MSFN to track the Shelter at any time, to a minimum slant range of 220,000 nautical miles, during which the Shelter is in line of sight of a MSFN station. The S-Band communications equipment shall aid the MSFN in determining spacecraft velocity by receiving a phase modulated carrier from the MSFN, and re-transmitting a carrier coherently related to a 240/221 ratio to the frequency of the received carrier. The Shelter shall aid the MSFN in determining accurately the spacecraft range through the reception, demodulation and re-transmission of a Pseudo-Random-Noise Ranging (PRN) Signal generated by the MSFN. This ranging capability shall be possible at any time when the MSFN and Shelter are communicating via the S-Band link when in the Phase Modulation Mode.

3.4.5.1.4 Telemetry Transmission. - The Shelter shall be capable of transmitting telemetry as follows:

- (a) Shelter to MSFN PCM Telemetry Transmission - The Shelter shall have the capability of providing Shelter data to the MSFN via a PCM telemeter and the S-Band link to a minimum slant range of 220,000 nautical miles. Two modes of telemetry capability shall be provided. A low bit rate output of 1600 bits/second and a high bit rate output of 51,200 bits/second.
- (b) Shelter to CSM PCM Telemetry Transmission - The inflight capability shall exist to transmit 1600 bits/second PCM data from the Shelter to the CSM via a VHF communications link to a minimum slant range of 300 nautical miles for recording onboard the CSM for subsequent playback to the MSFN.
- (c) EVA Data Relay - During extra-vehicular operations, the capability shall exist for the Shelter to relay transmissions from the EVA to the MSFN via the S-Band communications link. The capability shall also exist to check out the EMU data system prior to the egressing of the astronaut from the Shelter, by relaying the EMU Data System composite waveform to the MSFN for analysis via the S-Band Link.

SPECIFICATION NO. ESP-13-0100

3.4.5.1.5 Key Transmission. - An S-Band Transmission Mode shall exist that enables the transmission of manually encoded Morse code.

3.4.5.1.6 Biomedical Data Transmission. - Biomedical information shall be hardlined from each astronaut within the Shelter and processed for transmission via the S-Band Transmitter. Biomedical data shall be processed and transmitted for only one crewman at a time.

3.4.5.1.7 Up Data Link. - The Shelter shall be equipped to receive, decode and route commands from MSFN stations via S-Band.

3.4.5.2 Design Requirements. -

3.4.5.2.1 S-Band Section. - The S-Band section shall consist of the following equipment:

- (a) Transceiver Assembly
- (b) Power Amplifier Assembly
- (c) Diplexer
- (d) RF Switch
- (e) In-Flight Antenna
- (f) Steerable Antenna
- (g) RF Cable Assemblies
- (h) Switching Matrix
- (i) Erectable Antenna
- (k) Command Receiver

SPECIFICATION NO. ESP-13-0100

3.4.5.2.1.1 Transceiver Assembly. - The transceiver assembly shall consist of the following:

- (a) Two coherent transponders
- (b) One FM modulator capable of using either transponder multiplier chain.
- (c) Fail-Safe Switching

3.4.5.2.1.1.1 Coherent Transponders. - Each transponder shall consist of one phase locked receiver, one coherent phase modulator, a multiplier chain and power supply. The transponder shall permit ranging to the Shelter by the ground station as well as transmission of voice, telemetry, biomedical and EMU information from Shelter to the ground station. Simultaneous operation of transponders shall be precluded. The receiver shall be capable of detecting a carrier at 2101.802 mc, a voice modulated subcarrier, a data modulated sub-carrier and pseudo-random noise which is angle modulated by the ground transmitter. It shall also be capable of coherently translating and routing pseudo-random noise to the phase modulator (PM) in a coherent ranging mode. The transmitters shall be miniaturized, solid state devices capable of an RF output of 0.75 watts.

3.4.5.2.1.1.2 FM Modulator. - The FM modulator shall be provided for modes not requiring coherency. Simultaneous transmission of FM and PM shall be precluded.

3.4.5.2.1.1.3 Fail-Safe Switching. - Fail-Safe Switching shall be provided in the receiver section to automatically detect failure and switch to the secondary receiving section.

3.4.5.2.1.2 Power Amplifier Assembly. - The power amplifier assembly shall consist of two amplifier tubes, one input isolator, one output isolator, and two power supplies mounted in a common enclosure. The power amplifier assembly shall be capable of operation with either multiplier chain. Simultaneous operation of the two amplifiers shall be precluded. The power amplifier equipment shall provide a 20 watt RF signal to the S-Band diplexer. The equipment shall provide power amplification at 2282.5 mc.

SPECIFICATION NO. ESP-13-0100

3.4.5.2.1.3 Diplexer. - The diplexer shall permit the transmitter and receiver to utilize one antenna at a time and shall be physically attached to the power amplifier assembly.

3.4.5.2.1.4 RF Switch. - The RF switch shall enable the crewman to select the desired S-Band antenna.

3.4.5.2.1.5 In-Flight Antenna. - The in-flight antenna assembly shall consist of radiating elements and matching devices. The polarization shall be Right Hand Circular Polarization.

3.4.5.2.1.6 S-Band Steerable Antenna. - The S-Band steerable antenna shall be used for communications between Shelter and earth. During most phases of the lunar mission, the RF sensor shall track an earth transmitting station and direct the steering components of the antenna in such a manner as to obtain continuous Shelter earth communications. An automatic search mode shall be provided. Controls and displays shall be provided for antenna acquisition of an earth transmitting station from lunar distances, and for any required manual antenna steering.

3.4.5.2.1.7 RF Cable Assemblies. - The RF cable assemblies shall provide a means of interconnecting RF signals between the S-Band equipments.

3.4.5.2.1.8 Switching Matrix. - The Switching Matrix shall select the antenna system for the unmanned portion of the Shelter mission.

3.4.5.2.1.9 Erectable Antenna. - The Erectable Antenna shall be used for communication between the manned Shelter and earth. When Shelter is on the lunar surface the antenna shall be directional and be capable of manual adjustment to the slope of the terrain and the position of earth in the lunar sky. The polarization shall be RCP.

3.4.5.2.1.10 Command Receiver. - The Command Receiver shall turn on the S-Band equipment upon reception of a command from earth.

SPECIFICATION NO. ESP-13-0100

3.4.5.2.2 VHF Section. - The VHF section shall consist of the following equipment:

- (a) Two Transceivers (A and B)
- (b) Diplexer
- (c) RF Switch
- (d) In-Flight Antenna
- (e) EVA Antenna
- (f) RF Cable Assemblies

3.4.5.2.2.1 Transceivers. - Transceiver A shall be capable of simplex operation between Shelter and CM. The transmitter shall be a solid-state unit, modulated by infinitely clipped speech. The receiver shall contain automatic volume control (AVC) and squelch capabilities. Transceiver A shall operate at 296.8 mc. Transceiver B shall consist of a solid state unit capable of transmitting PCM data at 1.6 KB rate or, as in Transceiver A, infinitely clipped speech; it shall receive EMU information from the EVA or voice from the CM. The receiver shall also contain AVC and squelch capabilities. Transceiver B shall operate at 259.7 mc.

3.4.5.2.2.2 Shelter-EVA Communications. - The primary duplex link for Shelter EVA Communications shall utilize the Shelter 259.7 mc receiver for EVA voice data reception and the Shelter 296.8 mc transmitter would be used in conjunction with the Shelter 296.8 mc receiver for duplex, voice only, communications.

3.4.5.2.2.3 Diplexer. - The diplexer shall permit the VHF transceiver units to utilize the same antenna.

3.4.5.2.2.4 RF Switch. - The RF switch shall allow the crewman to select the desired antenna.

GRUMMAN AIRCRAFT ENGINEERING CORPORATION

Bethpage, L. I., N. Y.
CODE IDENT 26512

SPECIFICATION NO. ESP-13-0100

3.4.5.2.2.5 Inflight Antennas. - There shall be two circularly polarized antennas with matching devices.

3.4.5.2.2.6 EVA Antenna. - There shall be a linearly polarized antenna consisting of radiating elements and matching devices.

3.4.5.2.2.7 RF Cable Assemblies. - The RF cable assemblies shall provide a means of interconnecting RF signals between the VHF equipments.

3.4.5.2.3 Signal Processing Assembly. - The signal processing assembly (SPA) shall provide the following functions:

(a) Voice, EMU and Biomedical Signals -

- (1) Voice information shall be hardlined to the SPA from each crewman. The SPA shall process the voice information for input to the Shelter ICS, S-Band modulator and VHF modulator as determined by mode selection.
- (2) Biomedical information shall be hardlined to the SPA from each crewman within the Shelter and processed for transmission via the S-Band transmitter. Biomedical data will be processed and transmitted for only one crewman at a time.
- (3) The SPA shall be capable of processing received VHF signals and of routing them to the ICS and the S-Band transmitter as determined by mode selection. The SPA shall also be capable of processing the EMU information received from the EVA for subsequent transmission to earth. EMU data shall be processed from only one EVA at a time.
- (4) The SPA shall be capable of processing the S-Band received voice subcarrier and routing the audio to either astronauts' headsets or the VHF transmitters or both.
- (5) The SPA shall provide side tone for all VHF, S-Band and ICS voice paths.
- (6) The SPA shall provide control of associated equipment with both push-to-talk and voice-operated relay methods.

SPECIFICATION NO. ESP-13-0100

3.4.5.2.3 (Continued)

- (b) Other Signals - The SPA shall provide the interface between the pulse code modulation and timing equipment, voice recorder equipment, and the RF electronics, as related to the various modes of information transferral.

3.4.5.2.4 Up Data Link (UDL) (Command Decoder). - The UDL shall consist of the following equipment:

- (a) S-Band Section
- (b) Switching Section
- (c) Sub Bit Detector
- (d) Decoder Section
- (e) Buffer Interface Unit
- (f) System and Commands Interface

3.4.5.2.4.1 S-Band Section. - The S-Band section as described in 3.4.5.2.1, shall modulate the received data signal and routes subcarrier (70 Kc) to the switching section.

3.4.5.2.4.2 Switching Section. - The switching section shall consist of the following equipment:

- (a) Switch module 70 Kc
- (b) FM subcarrier discriminator 70 Kc

3.4.5.2.4.2.1 Switch Module 70 Kc. - The switch module 70 Kc shall, in the presence of a subcarrier 70 Kc from the S-Band receiver, switch on the power supply to the decoder section, buffer interface unit, systems and commands interface unit, FM discriminator 70 Kc and sub bit detector.

GRUMMAN AIRCRAFT ENGINEERING CORPORATION

Bethpage, L. I., N. Y.
CODE IDENT 26512

SPECIFICATION NO. ESP-13-0100

3.4.5.2.4.2.2 FM Discriminator 70 Kc. - The FM discriminator 70 Kc shall detect the subcarrier 70 Kc from the S-Band receiver and recover the composite 1 and 2 Kc signals.

3.4.5.2.4.3 Sub Bit Detector. - The sub bit detector shall detect the composite signal and recover the 1 Kc sync and the 2 Kc information bits.

3.4.5.2.4.4 Decoder Section. - The decoder section shall consist of the following equipment:

- (a) Program control and message verification unit
- (b) Vehicle address system
- (c) Systems address unit
- (d) Information or message register
- (e) System selector

3.4.5.2.4.4.1 Program Control and Message Verification Unit. - The program control and message verification unit shall confirm the validity of the received UDL signal. It shall determine the proper routing of the verified command.

3.4.5.2.4.4.2 Vehicle Address System. - The vehicle address system shall recognize those messages that are destined for the Shelter.

3.4.5.2.4.4.3 Systems Address Unit. - The systems address unit shall determine the proper length of the message and interface the system selector.

3.4.5.2.4.4.4 Information or Message Register. - The information or message register shall complete message information until complete and verified. It shall route verified messages to the system selector.

3.4.5.2.4.4.5 System Selector. - The system selector shall receive the verified message from the information or message register.

SPECIFICATION NO. ESP-13-0100

3.4.5:2.5 Associated Equipment. - The CS shall be capable of operation with the following associated equipments which are not a part of this subsystem:

- (a) Pulse Code Modulation and Timing Electronics Assembly (PCMTEA)
- (b) Data Storage Electronics Assembly (DSEA)
- (c) Displays and Controls Subsystem
- (d) Ascent and Descent Stage Structure
- (e) EMU Communications System (GFE)
- (f) Electrical Power Subsystem

3.4.6 Instrumentation Subsystem. - The instrumentation subsystem shall detect, measure, process, distribute and analyze various parameters encountered during the mission to:

- (a) Acquire data to determine Shelter status
- (b) Generate a "real-time" reference
- (c) Provide for selenologic experiment support.

3.4.6.1 Performance Requirements. - The Instrumentation Subsystem shall display data required by the crew for monitoring and evaluating the integrity and environment of the Shelter subsystems. The subsystem shall also provide data and "Real-time" reference for transmission to earth, for evaluation of either the performance or failure of any Shelter system.

GRUMMAN AIRCRAFT ENGINEERING CORPORATION

Bethpage, L. I., N. Y.
CODE IDENT 26512

SPECIFICATION NO. ESP 13-0100

3.4.6.1.1 Data Acquisition. - The instrumentation subsystem shall, with the aid of controls and displays, acquire and present the status of the Shelter subsystems to crew and ground stations for:

- (a) Aiding pre-flight assessment of Shelter readiness for launch
- (b) In-flight management of the Shelter housekeeping functions
- (c) Post-flight evaluation of performance
- (d) Maintaining a periodic status presentation capability with Earth during the quiescent state on the lunar surface

3.4.6.1.2 "Real-Time" Reference. - The Instrumentation subsystem shall generate a "Real-Time" reference and provide synchronizing signals to other Shelter equipment as required for all phases of the mission.

3.4.6.1.3 Selenologic Experiment Support. - The Instrumentation sections shall accept and integrate data from scientific equipment utilizing available spacecraft system, during the manned lunar stay of the Shelter.

3.4.6.2 Instrumentation Subsystem Design Requirements. - The Instrumentation Subsystem shall consist of:

- (a) Pulse Code Modulation and Timing Electronics Assembly (PCMTEA)
- (b) Signal Conditioning Electronics Assembly (SCEA)
- (c) Transducers
- (d) Caution and Warning Electronics Assembly (CWEA)
- (e) Voice Storage Recorder (VSR)

3.4.6.2.1 Pulse Code Modulations and Timing Electronics Assembly (PCMTEA). -

3.4.6.2.1.1 Data Distribution. - The PCMTEA shall convert analog data, parallel-digital data, and serial-digital data into serial non-return-to-zero (NRZ), Type C, binary-coded signals for signal processing

SPECIFICATION NO. ESP 13-0100

3.4.6.2.1.1 (Continued)

assembly. It shall also provide serial return-to-zero (RZ), Type C, binary-coded signals for prelaunch checkout equipment. The PCMTEA shall supply output data at a high bit rate of 51.2 kilobits per second. The primary operational mode for the PCMTEA shall be at the high bit rate. The lowest bit rate shall be used when power conservation is necessary during a mission. In general, design of the PCMTEA shall be based upon requirements of Inter-Range Instrumentation Group (IRIG) Standard, IRIG-106-60.

3.4.6.2.1.2 Timing Data. - The PCMTEA shall supply timing frequencies to synchronize Shelter-equipment, and binary-coded, decimal Greenwich Mean Time for telemetering. The timing equipment shall accept 1.024 mcs input as its master timing signal. As a secondary mode of operation the unit shall generate an internal, highly stable 1.024 mcs signal for operation of the PCMTEA when the external input is absent.

3.4.6.2.2 Signal Conditioning Electronics Assembly (SCEA). - The SCEA shall act as a junction box for all analog signals pertaining to status and housekeeping functions of the Shelter subsystems. The SCEA shall accept raw analog signals from transducers, signal pickoff points and contact closures from the Shelter subsystems and condition these signals to the proper voltage and impedance levels. Those signals not requiring conditioning will be routed through the data distribution subassembly of the SCEA. All conditioned analog signals shall be made available for routing to any combination of PCMTEA, CWEA and Displays.

3.4.6.2.3 Transducers. - The transducers shall sense and convert physical phenomena from all the vehicle subsystems into a form compatible with the SCEA. The transducers shall be capable of accepting excitation power from either the SCEA or the onboard power supply.

3.4.6.2.4 Caution and Warning Electronics Assembly (CWEA). - The CWEA shall provide two basic functions:

- (a) Caution function to advise the crew of an out-of-tolerance condition in a Shelter subsystem which does not require immediate attention, but could ultimately affect crew safety

SPECIFICATION NO. ESP 13-0100

3.4.6.2.4 (Continued)

- (b) Warning function to advise the crew of a malfunction which affects crew safety and requires immediate attention

3.4.6.2.4.1 Caution Function. - The CWEA shall remain ON during all manned phases of the Shelter mission. The CWEA shall accept signals from both the SCEA and the subsystems, and shall analyze these signals for out-of-tolerance conditions. The CWEA shall have reset capability. The Caution function shall activate a master alarm and onboard display whenever an out-of-tolerance condition exists.

3.4.6.2.4.2 Warning Function. - Inhibit gates contained in the CWEA shall be controlled by the subsystems to prevent false malfunction indications when a subsystem is intentionally made inoperative. The Warning function in the CWEA shall activate a master warning alarm and display onboard the Shelter and shall advise the ground station of a malfunction by telemetry.

GRUMMAN AIRCRAFT ENGINEERING CORPORATION

Bethpage, L. I., N. Y.
CODE IDENT 26512

SPECIFICATION NO. ESP 13-0100

3.4.7 Environmental Control Subsystem (ECS). - The ECS shall consist of:

- (a) Oxygen Supply and Pressurization Control Section
- (b) Atmosphere Revitalization Section
- (c) Heat Transport Section
- (d) Water Management Section
- (e) RTG Heat Utilization Section

The ECS is shown schematically in Figure 21.

3.4.7.1 Performance Requirements. - The ECS shall provide pressurization, atmospheric conditioning, ventilation, active thermal control, water management, and PLSS refilling.

3.4.7.1.1 Oxygen Supply and Pressurization Control Performance. - This section shall deliver in gaseous form all oxygen required by the ECS and shall maintain cabin or suit pressurization by supplying oxygen in sufficient quantities to replenish losses due to crew metabolic consumption, cabin leakage and airlock operation. This section shall also protect the cabin pressure shell against overpressurization and enable the crew to intentionally depressurize and repressurize the cabin. Capability shall be provided for TBD repressurizations of the airlock and TBD PLSS refills. The design of the Oxygen Supply and Pressurization Control Section shall be based on the following:

3.4.7.1.1.1 Cabin Criteria. -

- (a) Free volume: 235 ft³ for cabin; 85 ft³ for airlock.
- (b) Total leakage at 5.0 psia and 75 degrees Fahrenheit: 0.2 lbs/hour (inclusive of leakage of both cabin pressure relief and dump valves).
- (c) Repressurization time to an airlock pressure of 3.5 psia: TBD seconds maximum.
- (d) Repressurization time to a cabin pressure of 4.7 psia: TBD seconds maximum.

SPECIFICATION NO. ESP 13-0100

To be Determined

ENVIRONMENTAL CONTROL SUBSYSTEM (SCHEMATIC)

FIGURE 21

SPECIFICATION NO. ESP 13-0100**3.4.7.1.1.2 Cabin Pressure Relief and Dump Valve Criteria. -**

- (a) Maximum leakage at 5.0 psia and 75 degrees Fahrenheit (both valves): 0.01 lbs/hour.
- (b) Depressurization time (5.0 psia to 0.08 psia with no inflow): 200 seconds maximum.
- (c) Maximum cabin to ambient pressure differential: 5.8 psi.

3.4.7.1.1.3 Oxygen Criteria. -

- (a) PLSS refill: 0.91 lbs/refill at 850 psia.
- (b) PLSS supplementary oxygen tank capacity: TBD usable fluid.

3.4.7.1.1.4 Space Suit Criteria. -

- (a) Maximum leakage: 0.04 lbs/hour/suit at 3.7 psi and 70 degrees Fahrenheit.
- (b) Minimum purge flow: TBD.
- (c) Suit Pressure Increase Rate: TBD.

3.4.7.1.2 Atmosphere Revitalization Section Performance. - This section shall provide ventilation and atmospheric conditioning for the cabin, airlock and suits. Atmospheric conditioning shall consist of the removal of carbon dioxide, odors, particulate matter, and excess water vapor.

3.4.7.1.2.1 Suit Pressure Drop. - The pressure drop of each suit, including both halves of the suit umbilical hose disconnect shall be 5.0 inches of water at suit inlet conditions of 12 CFM at 3.5 psia and 50 degrees Fahrenheit.

3.4.7.1.2.2 Suit Inlet Temperature. - The range of suit inlet temperatures, for the conditions listed in Table II, shall be as follows:

SPECIFICATION NO. ESP 13-0100

3.4.7.1.2.2 (Continued)

Suit Inlet Temperature	Conditions	
	Min. Heat Load	Max. Heat Load
Minimum	45°F	60°F
Maximum	60°F	80°F

3.4.7.1.2.3 Suit Ventilation Flow. - The minimum suit ventilation flow rates of the cabin recirculation assembly shall be 5 lbs/min with one cabin fan operating and 10 lbs/min with both cabin fans operating.

3.4.7.1.3 Heat Transport Section Performance. - This section shall provide active thermal control of electrical and electronic equipment and cabin and suit ventilating gases.

3.4.7.1.3.1 Coolant. - The coolant shall be a TBD solution.

3.4.7.1.3.2 Coolant Temperature. - Coolant temperature limits during steady state operation shall be as follows:

(a) Minimum: TBD degrees Fahrenheit.

(b) Maximum: TBD degrees Fahrenheit.

3.4.7.1.3.3 Coolant Flow Rate. - The nominal coolant flow rate shall be TBD.

3.4.7.1.3.4 Coolant Pressure Drop. - The maximum total pressure drop of the coolant loop shall be TBD psi.

3.4.7.1.3.5 Thermal Loads. - The structural, electrical and electronic heat loads imposed upon the section shall be as shown in Table II. The cold plate thermal load characteristics shall be as shown in Table III.

SPECIFICATION NO. ESP 13-0100

ECS THERMAL DESIGN CRITERIA

TABLE II

SPECIFICATION NO. ESP 13-0100

3.4.7.1.4 Water Management Section Performance. - This section shall provide for storage and distribution of water used in the Shelter for PLSS refilling metabolic consumption by the crew and evaporative cooling. In addition, this section shall provide for the utilization of the condensed water vapor removed by the Atmosphere Revitalization Section and the collection and distribution of fuel cell by-product water.

3.4.7.1.4.1 PLSS Water Refill. -

- (a) Water quantity per refill: 6.8 lbs
- (b) Minimum refill pressure: 0.5 psi above cabin pressure

3.4.7.1.4.2 Water Storage. - Usable water quantity of the Descent tank shall be 244.0 lbs minimum.

3.4.7.1.5 RTG Heat Utilization Section. - The RTG Heat Utilization Section shall distribute heat from the Radioisotope Thermoelectric Generator (RTG) to the structure of the vehicle, when the structure temperatures drop below acceptable limits. The design of the RTG Heat Utilization Section shall be based on the following:

- (a) Fluid - Distilled water.
- (b) Temperature - The fluid temperature limits shall be as follows:
 - (1) Maximum: 250 degrees Fahrenheit.
 - (2) Minimum: 40 degrees Fahrenheit.
- (c) Pressure - The maximum operating pressure shall be 30 psia.
- (d) Capacity - The RTG Heat Utilization Section shall be capable of transporting 500 BTU/hr from the RTG and distributing it to the vehicle's structure.

SPECIFICATION NO. ESP 13-0100

3.4.7.2 Design Requirements. --

3.4.7.2.1 Oxygen Supply and Pressurization Control Section. -
The Oxygen Supply and Pressurization Control Section shall consist of:

- (a) Oxygen Supply Control Module.
- (b) High Pressure Oxygen Control Assembly.
- (c) Oxygen Hose Assembly.
- (d) Cabin Pressure Switch.
- (e) Cabin Pressure Relief and Dump Valve.
- (f) PLSS Supplementary Tank.

3.4.7.2.1 Oxygen Supply Control Module. - The Oxygen Supply Control Module shall sense the suit loop pressure and replenish the suit loop oxygen from the Shelter oxygen tank to maintain the selected suit loop pressure. The Module shall also contain a cabin repressurization emergency O₂ valve to dump oxygen into the cabin upon an electrical signal command from the cabin pressure switch, or by manual control. The Module shall contain provisions for filtering oxygen before it enters the suit loop or the cabin, and a manual control valve for recharging the PLSS.

3.4.7.2.1.2 High Pressure Oxygen Control Assembly. - The High Pressure Oxygen Control Assembly shall filter and reduce the PLSS Supplementary Tank and main oxygen tank pressure to a level compatible to the suit loop oxygen regulators.

3.4.7.2.1.3 Oxygen Hose Assembly. - An Oxygen Hose Assembly shall be provided for refilling the PLSS.

3.4.7.2.1.4 Cabin Pressure Switch. - The cabin pressure switch shall sense the absolute pressure in the cabin. The switch shall provide a signal to activate or deactivate the cabin repressurization emergency O₂ valve. This valve shall maintain the cabin pressure at 5 psia. When the cabin repressurization emergency O₂ valve is activated, the cabin pressure switch shall provide a signal to close the suit diverter valve. When the cabin pressure is below 3.0 psia, the cabin pressure switch shall also provide another switch closure to energize the cabin fan control relay.

SPECIFICATION NO. ESP 13-0100

3.4.7.2.1.5 Cabin Pressure Relief and Dump Valve. - The cabin pressure relief and dump valve shall be a three position servo valve with manual overrides on the automatic actuation. When the valve handle is in automatic position the valve shall open to the ambient whenever the cabin pressure exceeds 5.3 psia. With the valve handle in manual closed position the valve shall remain closed irrespective of the cabin pressure. With the handle in the manual open position the valve shall open to the ambient and allow a rapid reduction of cabin pressure.

3.4.7.2.1.6 PLSS Supplementary Tank. - The PLSS Supplementary Tank shall be capable of storing high pressure oxygen for PLSS refills.

3.4.7.2.2 Atmosphere Revitalization Section Design Requirements. - The Atmosphere Revitalization Section shall consist of:

- (a) Suit circuit.
- (b) Cabin recirculation assembly.
- (c) Steam flex duct.

3.4.7.2.2.1 Suit Circuit. - The suit circuit shall consist of three umbilical hose assemblies, the suit circuit assembly, and the carbon dioxide partial pressure sensor.

3.4.7.2.2.1.1 Suit Umbilical Hose Assembly. - Three suit umbilical hose assemblies shall be provided to carry ventilating gas to and from the crewman's space suit and the suit circuit assembly. The suit umbilical hose assembly shall be sufficiently flexible to provide required crew mobility in both the pressurized and unpressurized modes of suit operation.

3.4.7.2.2.1.2 Suit Circuit Assembly. - The suit circuit assembly shall provide heat exchangers for rejection of all waste heat to the Heat Transport Section for cooling, and for transfer of heat from the Heat Transport Section to the suit circuit gas stream for warming. A water evaporator shall reject waste heat when the heat exchanger is inoperative. Excess moisture condensed in the suit circuit shall be delivered by water separators to the Water Management Section. The carbon dioxide level in the suit circuit shall be maintained within limits by absorption in lithium hydroxide, and odors shall be absorbed in activated charcoal. Recirculation

SPECIFICATION NO. ESP 13-0100

3.4.7.2.2.1.2 (Continued)

of gas through the suit circuit shall be provided by fans. The fans shall be capable of maintaining the pressure vessel integrity of the suit circuit in the event of any internal fan failure.

3.4.7.2.2.1.3 Carbon Dioxide Partial Pressure Sensor. - The carbon dioxide partial pressure sensor shall measure the partial pressure of carbon dioxide in the ventilating gas entering the suits. The sensor shall provide output signals to displays and telemetry which indicate the value of the partial pressure of carbon dioxide.

3.4.7.2.2.2 Cabin Recirculation Assembly. - The cabin recirculation assembly shall provide for transfer of heat between the cabin gas and the Heat Transport Section, by means of the Cabin Heat Exchanger. The heat exchanger shall provide for storage of condensed moisture and for evaporation of water when the heat exchanger discharge gas is not saturated. The cabin fans shall recirculate cabin gas through the heat exchanger to maintain cabin gas temperature within limits and to provide cabin ventilation. The cabin fans shall be designed to permit operation at sea level for check-out purposes.

3.4.7.2.2.3 Steam Flex Duct. - A flexible duct shall be provided to carry the steam discharged from the suit circuit water evaporator.

3.4.7.2.3 Heat Transport Section Design Requirements. - The Heat Transport Section shall consist of the following:

- (a) Dual Capacity Coolant Recirculation Assembly.
- (b) Automatic Pump Switch Control.
- (c) Coolant Regenerative Heat Exchanger.
- (d) Cabin Temperature Control Valve.
- (e) Suit Temperature Control Valve.
- (f) Coolant Water Evaporator.
- (g) Coolant Accumulator.

SPECIFICATION NO. ESP 13-0100

3.4.7.2.3 (Continued)

- (h) Radiators
- (i) Radiator Control Valve
- (j) Cabin Structure Temperature Sensor
- (k) Cold Plate Assemblies
- (l) Flex Lines
- (m) GSE Quick Disconnect
- (n) Interstage Disconnect

3.4.7.2.3.1 Dual Capacity Coolant Recirculation Assembly. - The Dual Capacity Coolant Recirculation Assembly shall recirculate the coolant in the coolant loop, provide for removal of foreign particles in the coolant stream, incorporate provisions for isolating a failed pump, and limit the coolant pressure by providing for overpressure by-pass. During the quiescent mode the coolant flow shall be supplied at a reduced circulation rate by a pump having a low power consumption. Coolant flow for recirculation during the manned phase shall be supplied at the nominal rate by a higher capacity pump.

3.4.7.2.3.2 Automatic Pump Switch Control. - The Automatic Pump Switch Control shall actuate the low power consumption pump whenever a signal is received from the cabin structure temperature sensor. In addition, the Automatic Pump Switch Control shall shut off the operating pump and actuate another pump when a signal is received from the pump differential pressure sensor indicating that pump differential pressure has fallen below allowable limits. The control shall be capable of being manually overridden to permit the crew to select any pump.

3.4.7.2.3.3 Coolant Regenerative Heat Exchanger. - The coolant regenerative heat exchanger shall provide for transfer of the heat rejected from the electronic equipment to the coolant entering the cabin heat exchanger for heating of the cabin gas.

SPECIFICATION NO. ESP.13-0100

3.4.7.2.3.4 Cabin Temperature Control Valve. - A cabin temperature control valve shall be provided to control the temperature of the coolant supplied to the cabin heat exchanger. The control valve shall sense the temperature of the coolant leaving the cabin heat exchanger. The valve shall respond mechanically to divert and modulate the flow of coolant through the coolant regenerative heat exchanger for temperature control of coolant entering the cabin heat exchanger. The valve shall include provisions for manual reset of the control temperature and provide for manual control in the event of sensor failure.

3.4.7.2.3.5 Suit Temperature Control Valve. - The suit temperature control valve shall permit the crew to manually control the temperature of the ventilating gas delivered to their spacesuits. The valve shall effect this control by controlling the flow of warm coolant through the suit circuit regenerative heat exchanger.

3.4.7.2.3.6 Main Coolant Water Evaporator. - A coolant water evaporator of porous plate design shall provide for rejection of waste heat from the Heat Transport Section coolant by evaporating water. Water evaporated shall be discharged to the Shelter ambient atmosphere. The coolant water evaporator shall be designed to preclude overcooling of the coolant.

3.4.7.2.3.7 Coolant Accumulator. - The coolant accumulator shall maintain coolant pressure above the coolant vapor pressure at all points in the coolant loop and absorb normal volumetric changes of the coolant mass. Coolant pressure shall be maintained mechanically and the accumulator shall provide an electrical signal in the event of excessive reduction of the coolant volume within the loop.

3.4.7.2.3.8 Cold Plate Assemblies. - The Cold Plate Section shall consist of the following:

- (a) Structural (strip) cold plates
- (b) Non-structural (flat) cold plates

All cold plates shall be designed to permit removal of the equipment for which they provide thermal control without disconnecting the cold plates from the Heat Transport Section plumbing.

SPECIFICATION NO. ESP 13-0100

3.4.7.2.3.8.1 Strip Cold Plates. - Strip cold plates shall provide both active thermal control and structural support for those electrical and electronic equipments which utilize the Electronic Replaceable Assembly (ERA) packaging concept. The strip cold plates shall contain a single flow passage through which the Heat Transport Section coolant shall be circulated. This passage shall contain fins as required to provide adequate heat transfer surface area. Strip cold plates shall be provided for the electrical and electronic equipment as shown in Table III.

3.4.7.2.3.8.2 Flat Cold Plates. - Flat cold plates shall provide active thermal control for those electrical and electronic equipments which utilize packaging concepts other than the ERA concept. The flat cold plates shall contain a single flow passage through which Heat Transport Section coolant shall be circulated. Flat cold plates shall be provided for the electrical and electronic equipment as shown in Table III.

3.4.7.2.3.9 GSE Quick Disconnects. - Self-sealing quick disconnects shall be provided for the recirculation of coolant through the loop by the GSE during ground operation of the Heat Transport Section.

3.4.7.2.3.10 Flex Lines. - Flex lines shall be provided to accommodate relative motion between the interstage disconnect halves and the adjacent hard line coolant plumbing.

3.4.7.2.3.11 Radiators. - The space Radiator design shall provide for rejection of waste heat from the Heat Transport Section coolant by controlled radiant exchange of heat between the Radiator surface and the Radiator environment. The Radiator shall be designed to experience large variations in Lunar thermal environment while maintaining the temperature of the heat transport fluid leaving the radiators within the acceptable limits.

SPECIFICATION NO. ESP 13-0100

TABLE III

SPECIFICATION NO. ESP 13-0100

3.4.7.2.3.12 Coolant Temperature Control Valve. - The Coolant Temperature Control Valve shall control the temperature of the coolant downstream of the radiators. The valve shall modulate the flow of coolant leaving the radiators through a regenerative heat exchanger whose hot side is directly upstream of the radiators. The valve shall include provisions for manual control in the event of sensor failure.

3.4.7.2.3.13 Radiator Regenerative Heat Exchanger. - The coolant Regenerative Heat Exchanger shall provide for transfer of the heat from the coolant upstream of the radiators to the coolant downstream of the radiators.

3.4.7.2.3.14 Radiator By-Pass Valve. - The Radiator by-pass valve shall enable the coolant to by-pass the radiators during the quiescent mode.

3.4.7.2.3.15 Cabin Structure Temperature Sensor. - The Cabin Structure Temperature Sensor shall send a signal to the condensate control valve control (Part of RTG Heat Utilization Section) and the Automatic pump switch control whenever the cabin structure temperature drops below the acceptable limit.

3.4.7.2.4 Water Management Section Design Requirements. - The Water Management section shall consist of the following:

- (a) Descent Stage Water Tank.
- (b) FCA Water Management Tank.
- (c) GSE Connections.
- (d) Water Control Assembly.
- (e) Water Hose Assembly.
- (f) Water Conditioning Assembly.

3.4.7.2.4.1 Descent Stage Water Tank. - The Descent Stage Water Tank shall provide adequate usable storage for water above Fuel Cell Assembly water production. The tank shall be spherical and shall provide positive expulsion of water by use of a bladder and standpipe design.

3.4.7.2.4.2 FCA Water Management Tank. - TBD.

3.4.7.2.4.3 GSE Connections. - The GSE Connections shall provide for evacuation, fill and pressurization of the water tanks. The disconnect half of the connector shall include protective capping against leakage due to failure of the self-sealing feature.

SPECIFICATION NO. ESP. 13-0100

3.4.7.2.4.4 Water Control Assembly. - The Water Control Assembly shall provide the following:

- (a) Prevent the flow of water from the Water Control Assembly to the Fuel Cell Assembly.
- (b) Prevent the flow of water from the Water Control Assembly to the water separator.
- (c) Prevent the flow of water from the Water Control Assembly to the Descent Stage Water Tank.
- (d) Prevent the flow of water from the water separator to the Fuel Cell Water Management Tank.
- (e) Control the flow of water from the Water Control Assembly to the Water Hose Assembly and the coolant water evaporator.
- (f) Control water pressure from the FCA Water Management Tank to the Water Hose Assembly and the coolant water evaporator.
- (g) Provide overboard relief in the event of a regulator failure.

3.4.7.2.4.5 Water Hose Assembly. - The Water Hose Assembly shall provide for the transfer of water from the Water Control Assembly to the water storage tanks of the PLSS.

3.4.7.2.4.6 Water Conditioning Assembly. - The Water Conditioning Assembly shall supply hot and cold water to the shutoff valve.

3.4.7.2.5 RTG Heat Utilization Section. - The RTG Heat Utilization section shall provide for the transport of a portion of the heat emitted by the Radioisotope Thermoelectric Generator (RTG). The heat shall be transferred through the RTG Heat Utilization equipment to the vehicle structure. The RTG Heat Utilization Section shall operate on signals from temperature sensors in the cabin structure.

GRUMMAN AIRCRAFT ENGINEERING CORPORATION

Bethpage, L. I., N. Y.
CODE IDENT 26512

SPECIFICATION NO. ESP. 13-0100

3.4.8 Crew Provisions Subsystem (CPS). - Crew Provisions Subsystem shall support the nominal and abort missions by providing the equipment or the volume for equipment (CFE and GFE) integrated into a cohesive pressurized cabin arrangement. Crew aids, lighting and marking on the exterior of the vehicle shall be provided to the extent required. The cabin arrangement shall be designed to reflect task requirements for the crew.

3.4.8.1 Crew Equipment Performance Requirements. -

3.4.8.1.1 Extravehicular Mobility Unit (EMU). - A self donnable and doffable EMU (CFE) shall be provided for environmental protection and life support of the crew in or outside the cabin. The EMU, in conjunction with the vehicle ECS, shall provide a secondary environmental and life support protection, necessary in the event of a pressure failure within the vehicle. In a pressurized mode the EMU shall not reduce the capability of the crew to adequately perform the tasks essential to crew safety and mission success.

3.4.8.1.2 Crewman Umbilicals. - Umbilicals shall provide the environment necessary for the crew. The umbilicals shall be routed to provide necessary mobility for crew tasks within the cabin. The required ECS umbilicals, housing the communication, electrical and instrumentation cables shall be assembled into one primary umbilical assembly for each crewman for use in intravehicular operation.

3.4.8.1.3 Ingress and Egress. - Crew ingress and egress routes to and from free space shall be free of protuberances or unprotected areas which would act as a snare or otherwise hamper crew transfer. Hand grips and foot holes shall be in accordance with human factors and cabin arrangement. This arrangement shall provide for crew egress - ingress to and from the lunar surface via an alighting ladder from the hatch to a platform located on the exterior surface. Hand and foot holds to assist in descending and ascending from the vehicle shall be provided. In addition, an air lock shall be provided to enable a crewman to egress - ingress the vehicle without depressurizing the cabin compartment.

3.4.8.1.4 Stowable Government Furnished Equipment. - As a minimum, the following GFE shall be stored aboard the Shelter:

SPECIFICATION NO. ESP 13-0100

3.4.8.1.4 (Continued)

- (a) Portable Life Support System (PLSS)
- (b) PLSS Calibration Unit
- (c) PLSS Spare Parts
- (d) Pressure Garment Assembly
- (e) Thermal Meteoroid Garment
- (f) Extravehicular Boots
- (g) Extravehicular/Intravehicular Gloves
- (h) Extravehicular Mittens
- (i) Suit Repair Kit
- (j) External Visor Assembly
- (k) Auxiliary PLSS Battery
- (l) Radiation Survey Meter
- (m) LiOH Cartridges
- (n) First Aid Kit
- (o) Water Probe
- (p) Food Packages (including disinfectant)
- (q) Emergency Oxygen System
- (r) Umbilical Stowage Fitting
- (s) Coupling Display Units

SPECIFICATION NO. ESP 13-0100

3.4.8.1.4 (Continued)

- (t) Eye Register and Reticule
- (u) Two Digit Readout for Reticule
- (v) Inflight Data Management Kit
- (w) EMU - Radiation Dosimeter
- (x) EMU - Bioinstrumentation
- (y) Constant Wear Garments
- (z) Liquid Cooled Garment
- (aa) Battery Charger (PLSS)
- (bb) EMU Spare Parts
- (cc) Hard Space Suits

3.4.8.1.5 Waste Management. - The Waste Management section shall operate in a shirt-sleeve environment with automatic and manual shutoff provision, and shall provide the following:

- (a) Transfer of urine from the EMU
- (b) A Feces Waste Management Device (GFE)

3.4.8.2 Cabin Arrangement Design Requirements. - The cabin arrangement shall provide for effective performance of the crew tasks by efficient storage of associated equipment and expendables, and the establishment of appropriate crew primary and secondary stations. The cabin shall consist of a 92 inch inside diameter cylindrical forward cabin and a 54 inch long cylindrical equipment tunnel with a total volume of approximately 250 cubic feet. The forward cabin, which accounts for about two-thirds of the total volume, shall contain the primary stations and most of

SPECIFICATION NO. ESP 13-0100

3.4.8.2 (Continued)

the controls and displays. The cabin arrangement and crew station shall accommodate the required ranges of crew sizes (10-90 percentile men) with respect to reach, body clearance, visibility, mobility, "cubical" size and body position or attitude.

3.4.8.2.1 Primary Station. - Two side by side flight stations shall be provided for crewmen. A design reference point (design eye) shall be established to orient flight station geometry for the required balance between external visibility, visual and physical access to controls and displays. Instrument panels, windows, glare shields and controllers shall be oriented with respect to this design reference point. The flight station shall be provided with the necessary floor to overhead height and body clearance to accept all crewmen in the 10-90 percentile anthropomorphic body size. It is not mandatory that the crewmen be indexed at the "design eye" in order to effectively perform the assigned tasks, therefore, no adjustment with respect to the floor will be operationally employed for this purpose.

3.4.8.2.2 Secondary Station. - A secondary station is located in the center aisle between the individual stations. The donning station shall be in the center aisle. A removable height adjusting PLSS supporting harness shall permit donning and doffing of the PLSS backpack. A recharge station shall be provided on the side of the tunnel for recharging the PLSS, water, battery and oxygen. This station shall be accessible from the forward cabin.

3.4.8.2.3 Lighting. -

3.4.8.2.3.1 Internal Lighting. - A primary and secondary means of control and display panel illumination shall be provided. These shall include integral and floodlighting by electroluminescent, incandescent

SPECIFICATION NO. ESP 13-0100

3.4.8.2.3.1 (Continued)

or self-luminous methods as required. Lighting shall be provided for illuminating the cabin areas.

3.4.8.2.3.2 External Lighting. - External lighting shall be provided as a visual aid for crewmembers.

3.4.8.2.4 Displays and Controls. - The displays and controls shall be mounted in panels and consoles consistent with the crew station and conforming to the human factor and geometry capability of the crewmen. The panel arrangement shall consist of tiered side panels, sloping to provide greater surface area, recessed protection of controls and displays, and to approximate normal inclination to the line of sight. A main panel shall be located between the forward windows which will permit visual and physical access by both crewmen in the primary station. Exposed areas of the panels or the displays shall not exceed a gloss level of 5 units as measured by ASTM Method D523 of Specification MIL-P-7788A. The panels and consoles shall be designed for efficient ground service maintainability.

3.4.8.2.5 Crew Aids. - Provisions or aids shall be included to permit safe transfer of crewmen and equipment in and out of the vehicle. Provisions shall also be provided for resting and sleeping during the mission.

- (a) Interior and exterior aids shall be provided to facilitate crew mobility. Hand holds, foot holes, alighting ladders, platforms and tether line attachments shall be used for this purpose.
- (b) A bunk, anchored at the floor and supported from above by cables, shall be provided for each crewman. The bunk shall be of a webbed type construction capable of supporting the crewman in either shirt-sleeve or EMU configuration. When not in use, the bunk with supporting cables shall be capable of being rolled or folded for storage.

SPECIFICATION NO. ESP 13-0100

3.4.8.2.5 (Continued)

(c) Flat seats, capable of swiveling to the primary areas shall be provided. The seats shall be stowable when not in use.

(d) Work Tables

3.4.8.2.6 Marking and Identification. - Markings for interior and exterior areas, coloring and identification, including nomenclature shall be provided as required to support the performance of tasks by crewmen and ground servicing personnel.

3.4.8.2.7 Inboard Profile Drawing. - The inboard profile drawing in Figure 22 depicts the arrangement of the equipment to support the crew in the performance of their duties.

~~CONFIDENTIAL~~

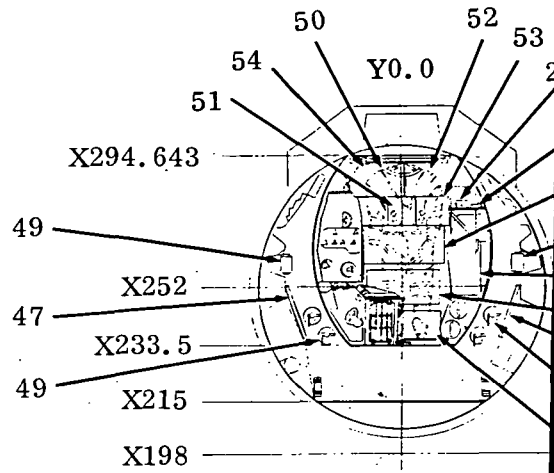

View Looking Aft At Z +

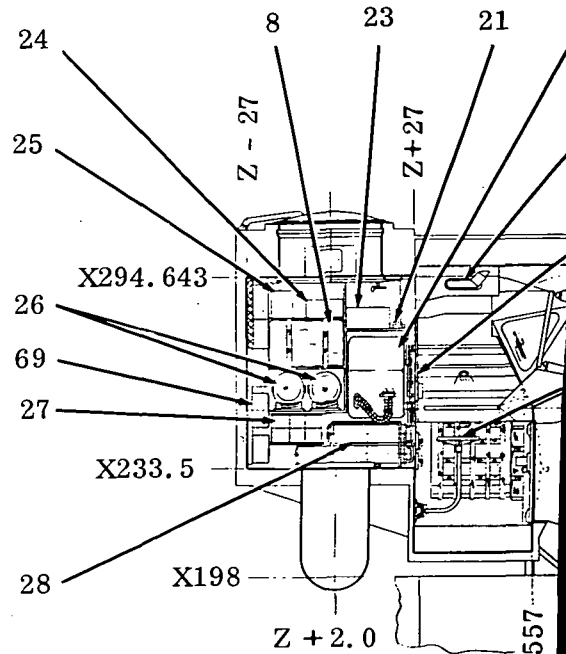

~~CONFIDENTIAL~~

141
①

~~CONFIDENTIAL~~

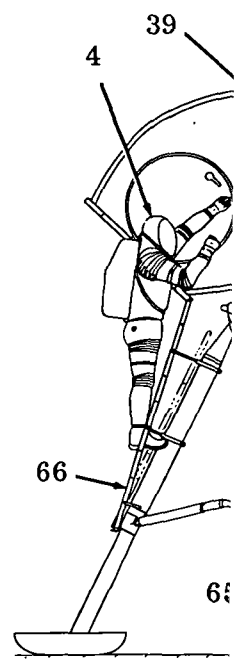
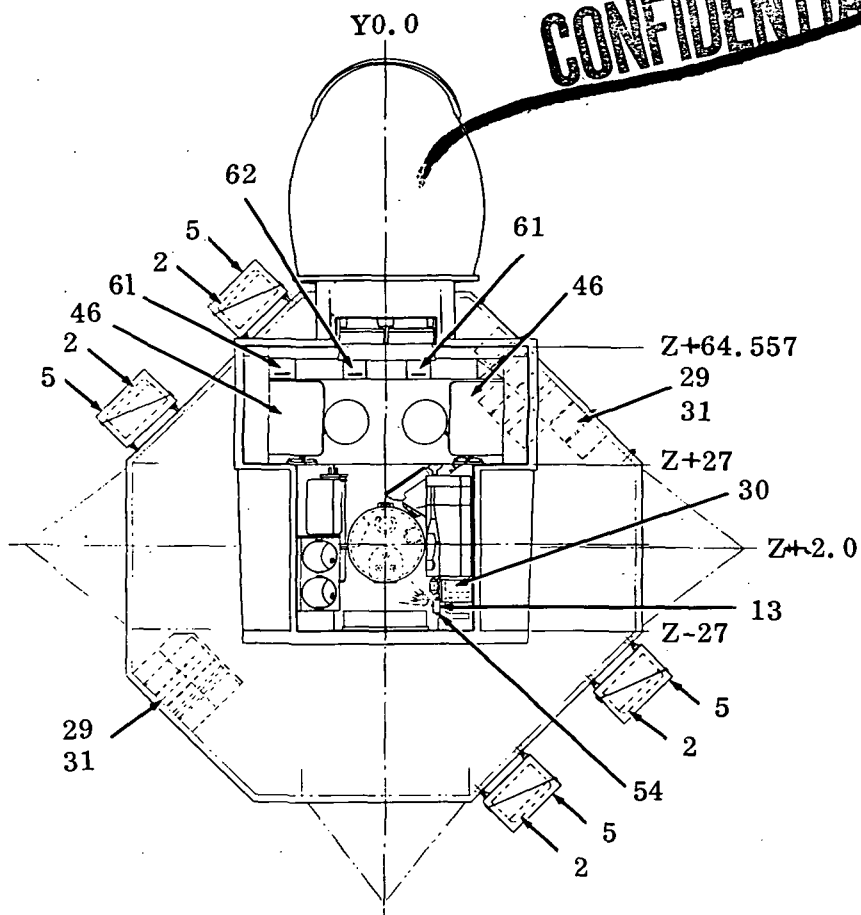

Plan View

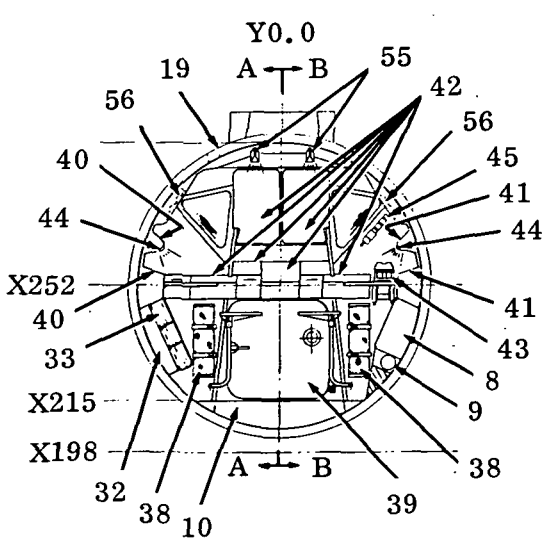
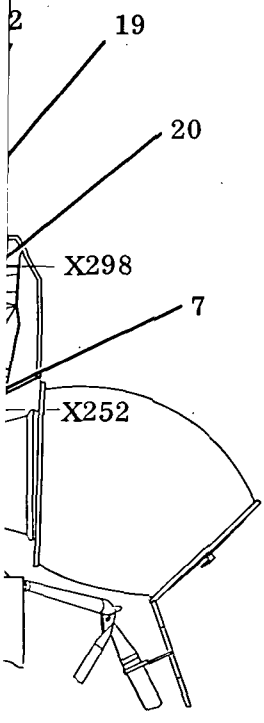

View Looking Fwd At Z+27.0

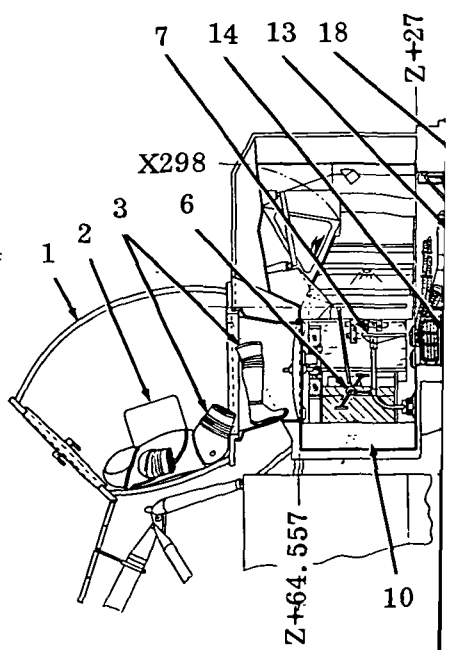

Section B-B View Looking

~~CONFIDENTIAL~~

141 (a)

~~CONFIDENTIAL~~

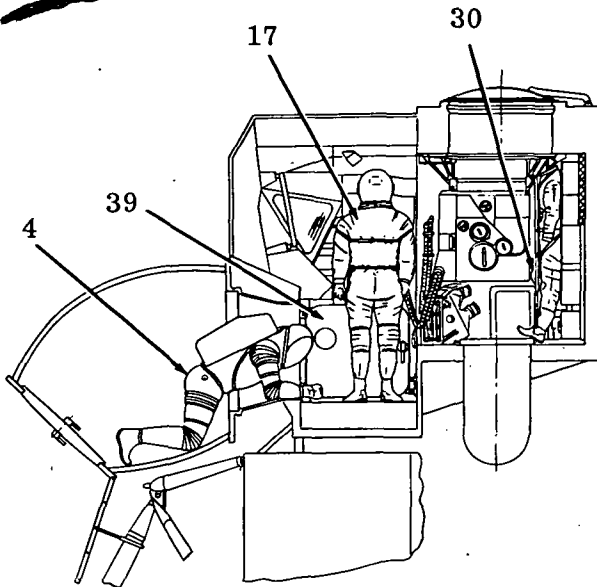
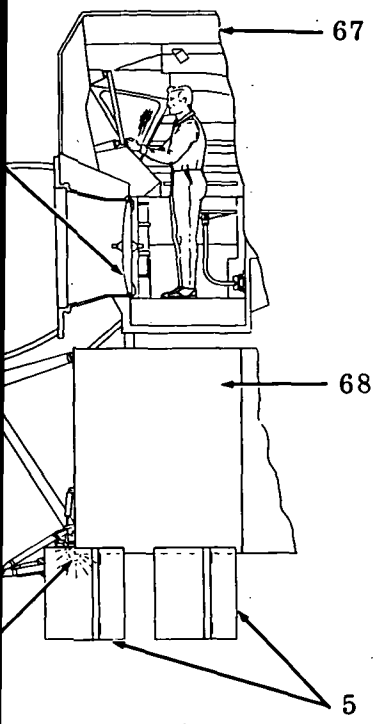

Entering Cabin Through Airlock

Entering Airlock

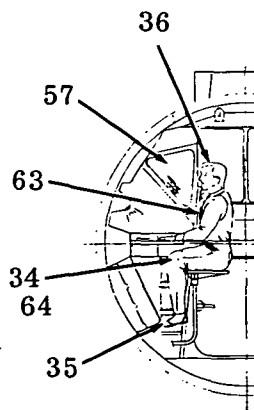
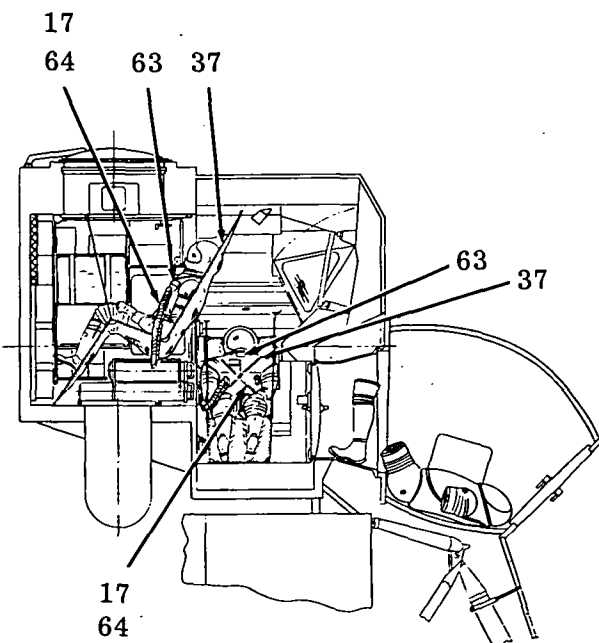
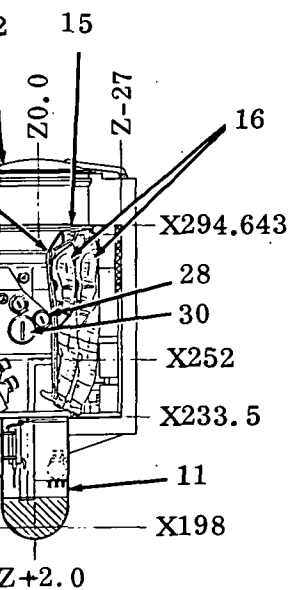

Crew At Work

utb'd - R. H. Side

Sleeping Arrangement
In Mid and Cabin Section

~~CONFIDENTIAL~~

14
(3)

~~CONFIDENTIAL~~

Key

1. Airlock (Expandable Type)
2. PLSS (6, Including Six Batteries & Six LiOH)
3. Hard Suit (Stored)
4. Hard Suit (Worn)
5. PLSS External Storage Facility (4)
6. Exercise Equipment - Bicycle Ergometer
7. Adjustable & Stowable Swivel Seat (2)
8. Anti-Meteoroid/Thermal Garment (2 Stored)
9. Suit Servicing Kit (2)
10. Food Storage (3.1 cu. ft.)
11. Waste Management System
12. Upper Thermal Hatch
13. ECS Pkg (Suit And Cabin)
14. Blower/Heat Exchanger
15. Upper Hatch (Docking)
16. Soft Suit (2, Stored)
17. Soft Suit (Worn)
18. Water-Cooled Garment (WCG, 2, Stored)
19. Docking Window
20. PLSS Recharging Umbilical (2)
Waste Management Urine Umbilical
21. PLSS Calibration Unit
22. Water Probe
23. EVA Boots (2 Pairs Stored)
24. Intravehicular Slippers (2 Pairs, Stored)
25. Exercise Equipment (Stored)
 - Bungee Cord
 - Hand Ergometer
26. Soft Suit Helmet (2, Stored)
27. PLSS Batteries (6, Stored)
28. PLSS LiOH Cartridge (6, Stored Internally)
29. PLSS LiOH Cartridge (26, Stored Externally)
30. ECS LiOH Cartridge (2, Stored Internally)
31. ECS LiOH Cartridge (12, Stored Externally)
32. Program Coupler Assembly Structure
33. Constant Wear Garments (CWG, 14, Stored)

10 20 30 40 50 60 70 80 90 100
SCALE - 1/20

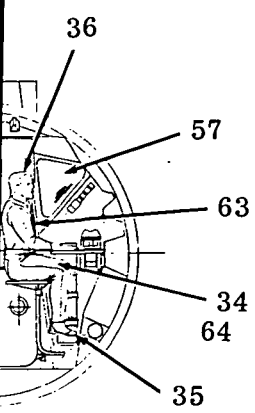

Work Stations

~~CONFIDENTIAL~~

141
④

34. CWG (Worn)
35. Intravehicle Slippers (Worn)
36. Crew (2) In CWG
37. Bunk (2, Deployed)
38. Bunks (Stored)
39. Front Hatch (Ingress/Egress)
40. L. H. Control Panels
41. R. H. Control Panels
42. Front Control Panels
43. Attitude Controller & Arm Rest
44. Work-Top Light (2)
45. Radiation Survey Meter
46. Work-Top (2) Deployed
47. Work-Top (Stored)
48. Voice Storage Recorder (2)
49. Emergency Oxygen Equipment (4)
50. Personal Hygiene Equipment (Stored)
51. Housekeeping Equipment (Stored)
52. Medical Equipment (Stored)
53. Recreation Equipment (Stored)
54. Mid-Section Dome Light
55. Cabin Section Flood Lights (2)
56. Circuit Breakers (L. & R. Side)
57. Windows (2)
58. LGS
59. CDU
60. PSA
61. Tissue Equivalent Ionization Chamber (Rate Meter, 2, Stored)
62. Tissue Equivalent Ionization Chamber (Rate Meter Charger, Stored)
63. Tissue Equivalent Ionization Chamber (Integrating, 2, Worn)
64. Passive Dosimeter (7 Per Man, Worn)
65. External Flood Light (2, Front And Rear)
66. Adjustable Ladder
67. Shelter
68. Descent Stage
69. Cold Plate

Fig. 22 Inboard Profile

GRUMMAN AIRCRAFT ENGINEERING CORPORATION

Bethpage, L. I., N. Y.
CODE IDENT 26512

SPECIFICATION NO. ESP 13-0100

3.4.9 Displays and Controls Subsystem (D&C). - The D&C equipment shall present information and accommodate inputs for the following purposes:

- (a) Prior to separation, a crewman shall monitor the Displays and Controls Subsystem and set those controls necessary to allow the Shelter to perform the unmanned landing and to operate during the quiescent mode.
- (b) During the manned phase the D&C shall provide the following:
 - (1) Operation of Shelter subsystem and management of subsystem condition.
 - (2) Management of Shelter stored propellants and energy sources.
 - (3) Alarm for hazardous conditions and Shelter subsystem malfunctions affecting the mission.

3.4.9.1 Performance Requirements. -

3.4.9.1.1 Engine/Thrust Control. -

<u>Control/Indicator</u>	<u>Function</u>
Attitude Controller (CDR)	The 3-axis Attitude Controller shall provide attitude command signals.

3.4.9.1.2 Circuit Breaker

CDR Panel and SE Panel	The circuit breakers within the vehicle shall provide electrical fault protection. Some circuit breakers shall serve as ON-OFF controls.
------------------------	--

3.4.9.1.3 Explosive Devices (ED). -

RCS Pressurization Switch	This switch shall activate all squib valves necessary to pressurize the Reaction Control Subsystem.
---------------------------	---

GRUMMAN AIRCRAFT ENGINEERING CORPORATION

Bethpage, L. I., N. Y.
CODE IDENT 26512SPECIFICATION NO. ESP 13-0100

3.4.9.1.3 (Continued)

<u>Control/Indicator</u>	<u>Function</u>
Master Arm Switch	This switch shall arm all explosive devices.
Descent Engine Pressurization Switch	This switch shall activate all squib valves necessary to pressurize the descent propulsion subsystem.
Landing Gear Deployment Switch	This switch shall activate the ED which extends the landing gear.
Landing Gear Status Indicator Flag	This flag indicates the stowed or deployed status of the landing gear.

3.4.9.1.4 Reaction Control Subsystem. -

<u>Control/Indicator</u>	<u>Function</u>
Thruster Pair Switches System B	Eight switches shall actuate a TCA isolation valve controlling the fuel and oxidizer flow to the TCA.
Temperature/Pressure Monitor Switch (Modified to Pressure Monitor)	This switch shall select: (a) helium, fuel and oxidizer tank pressure and temperature; (b) fuel and oxidizer tank pressure and temperature; (c) fuel and oxidizer manifold pressures on the pressure and temperature indicators.
Helium Regulator Switches System B	Four switches shall control solenoid operated shut off valve of system B, upstream of the pressure regulators in each helium leg.
Test Switch	This switch shall be used to isolate a leaking thrust chamber assembly, or to test the gaging assembly (in conjunction with the quantity monitor switch and the propellant quantity indicators).

GRUMMAN AIRCRAFT ENGINEERING CORPORATION

Bethpage, L. I., N. Y.
CODE IDENT 26512SPECIFICATION NO. ESP 13-0100

3.4.9.1.4 (Continued)

<u>Control/Indicator</u>	<u>Function</u>
Main Shut-off Switch System B	Two switches actuate latch type solenoid valves which control the flow of propellant downstream of the propellant tanks.
Pressure Indicator System B	This indicator shall display the pressure in the helium, fuel or oxidizer tanks or manifolds as selected by the monitor switch.
Oxidizer Quantity Indicator, Fuel Quantity Indicator (two digital displays)	These digital indicators shall display oxidizer and fuel quantities left in system A or B.
Regulator No. 1 Status; System B Regulator No. 2 Status System B (two 2-position flags)	Each of two 2-position flags shall indicate the open or closed status of its respective solenoid valve.
Main Shut-off Status System B	One 2-position flag shall indicate the open or closed status of its respective solenoid valves.
Thruster Pair Status Quad. No. 1, System B Quad. No. 2, System B Quad. No. 3, System B Quad. No. 4, System B	One 2-position flag shall indicate the open or closed status of its respective solenoid valves.

3.4.9.1.5 Flight Controls. -

<u>Control/Indicator</u>	<u>Function</u>
IMU Cage Switch	This switch shall provide an emergency function allowing recovery of the IMU to a zero position.
Elapsed Time Indicator	This indicator shall display Shelter mission elapsed time in hours, minutes and seconds.

GRUMMAN AIRCRAFT ENGINEERING CORPORATION

Bethpage, L. I., N. Y.
CODE IDENT 26512SPECIFICATION NO. ESP 13-0100

3.4.9.1.5 (Continued)

<u>Control/Indicator</u>	<u>Function</u>
Digital Event Timer	This indicator shall display time in minutes and seconds on a 4 digit display.
Elapsed Time Set Control	This control shall allow setting of the elapsed timer.
Timer Control Switch	This switch shall have momentary contacts for the start and stop positions.
Reset/Count Control Switch	This 3-position toggle switch shall determine the direction the digital event timer will count after it is manually started.
Slew Control Minutes Switch	This momentary toggle switch shall slew the minutes' digits of the digital event timer.
Slew Control Seconds Switch	This momentary toggle switch shall slew the seconds' digits of the digital event timer.

3.4.9.1.6 Main Propulsion. -

<u>Control/Indicator</u>	<u>Function</u>
Descent Regulator Switch (H_e)	This switch shall control a latch-type solenoid valve located upstream of the pressure regulator.
Fuel Pressure Meter Oxidizer Pressure Meter	This dual scale meter displays fuel and oxidizer pressure for the descent subsystem.

GRUMMAN AIRCRAFT ENGINEERING CORPORATION

Bethpage, L. I., N. Y.
 CODE IDENT 26512

SPECIFICATION N.O. ESP 13-0100

3.4.9.1.6 (Continued)

<u>Control/Indicator</u>	<u>Function</u>
Descent Regulator (H _e) Status No. 1 and No. 2	Two 2-position flags indicate the open or closed status of the respective solenoid valve.

3.4.9.1.7 GN & C Stabilization and Control. -

<u>Control/Indicator</u>	<u>Function</u>
Attitude Control Switch Pitch	Each of these switches shall select direct or pulse operation. These switches shall provide individual selection in each attitude axis.
Attitude Control Switch Roll	
Attitude Control Switch Yaw	
Attitude Control Mode Switch (Modified)	

3.4.9.1.8 Radar. -

<u>Control/Indicator</u>	<u>Function</u>
Signal Strength Meter	The meter displays various signals depending on the setting of the Test/Monitor switch.
Test/Monitor Switch (Modified)	Six position rotary switch for testing and monitoring of radar.

3.4.9.1.9 Communications. -

<u>Control/Indicator</u>	<u>Function</u>
Modulator Select Switch	This switch shall select phase modulated or frequency modulated transmission mode of the S-Band transmitter.
Transmitter/Receiver Select Switch	This switch shall select either of two redundant transmitter/receiver subassemblies.

GRUMMAN AIRCRAFT ENGINEERING CORPORATION

Bethpage, L. I., N. Y.
CODE IDENT 26512SPECIFICATION NO. ESP 13-0100

3.4.9.1.9 (Continued)

<u>Control/Indicator</u>	<u>Function</u>
Power Amplifier Select Switch	This switch shall select either of two redundant S-Band power amplifiers.
Voice Function Select Switch	This switch shall select either normal voice or backup voice function of the S-Band transmitter.
PCM/Key Function Select Switch	This switch shall select either the telemetry or Morse code keying function for transmission via the S-Band equipment.
Biomed Select Switch	This switch shall select biomedical data to be telemetered.
PCM Rate Select Switch	This shall select the high or low bit rate to be transmitted.
VHF Mode Select Switch	This switch shall be used in conjunction with the VHF transmitter/receiver select switch.
VHF A Squelch Control VHF B Squelch Control	These controls shall permit the adjustment of the threshold of the VHF A or B receiver squelch circuit.

3.4.9.1.10 Audio Control Panel (2 Identical Panels). -

<u>Control/Indicator</u>	<u>Function</u>
S-Band Switch	This switch shall tie the respective audio center into the S-Band transmitter/receiver circuitry.
ICS Switch	This switch shall tie the audio into the intercom circuitry.
Relay Switch	This switch shall tie the VHF into the S-Band transmitter/receiver circuit to provide voice communications between the Shelter, earth, EVA or CM.

GRUMMAN AIRCRAFT ENGINEERING CORPORATION

Bethpage, L. I., N. Y.
CODE IDENT 26512SPECIFICATION NO. ESP 13-0100

3.4.9.1.10 (Continued)

<u>Control/Indicator</u>	<u>Function</u>
VHF A Switch VHF B Switch	These switches shall tie the respective audio center into the VHF A or B transmitter/receiver circuit.
VOX Switch	This switch shall provide either voice operated relay activation or push-to-talk keying of transmitters.
VOX Sensitivity	This control shall adjust the level of voice input required to activate the voice operated relay.
S-Band Volume Control	This control shall adjust the level of the S-Band audio input to the headphone.
ICS Volume Control	This control shall adjust the level of the intercom audio input to the headphone.
VHF A Volume Control VHF B Volume Control	These controls shall adjust the level of the VHF A or B audio input to the headphone.
Master Volume Control	This control shall adjust simultaneously the level of all audio inputs to the headset through the respective audio center.

3.4.9.1.11 Communications Antennas. -

<u>Control/Indicator</u>	<u>Function</u>
Pitch Antenna Control	This control shall drive the S-Band antenna in the pitch axis.
Yaw Antenna Control	This control shall drive the S-Band antenna in the yaw axis.
Track Mode Select	This switch shall select either the auto or manual mode of track of the S-Band antenna.

GRUMMAN AIRCRAFT ENGINEERING CORPORATION

Bethpage, L. I., N. Y.
CODE IDENT 26512SPECIFICATION NO. ESP 13-0100

3.4.9.1.11 (Continued)

<u>Control/Indicator</u>	<u>Function</u>
WFF Antenna Select	This switch shall select the WFF antennas as well as a test position to check out ENU information exchange.
Signal Strength Meter	This meter shall monitor the S-Band signals received from the earth.
Antenna Pitch Meter	This meter shall display the pitch angles of the S-Band steerable antenna.
Antenna Yaw Meter	This meter shall display the yaw angle of the S-Band steerable antenna.
"No Track" Light	This component caution light indicates that the S-Band steerable antenna has broken track with the RF signal transmitted from earth.

3.4.9.1.12 Electrical Power Supplies. -

<u>Control Indicator</u>	<u>Function</u>
Battery No. 1 High Voltage Control Switch	Each 3-position toggle shall control the high voltage power output from the descent batteries.
Battery No. 2 High Voltage Control Switch	
Battery No. 3 High Voltage Control Switch	
Battery No. 1 Low Voltage Control Switch	Each 3-position toggle shall control the low voltage power output from the descent batteries.
Battery No. 2 Low Voltage Control Switch	
Battery No. 3 Low Voltage Control Switch	
AC Power Control Toggle	This 3-position toggle shall control AC power to the AC bus.
Battery Temperature Indicator	This meter shall indicate battery temperature in Fahrenheit.
Voltmeter	This meter shall indicate the voltage of any battery or bus in the EPS.

SPECIFICATION NO. ESP 13-0100

3.4.9.1.12 (Continued)

<u>Control/Indicator</u>	<u>Function</u>
Ammeter	This meter shall indicate the current drain of the batteries.
Over Temperature Light Reverse Current Light	This light shall warn of battery overheating.
Descent Battery No. 1 Status	These flags shall indicate the battery is on the line when the gray position is in view. The battery is off the line when the "barber-pole" position is in view.
Descent Battery No. 3 Status	
Fuel Cell Heaters	Displays TBD
Fuel Cell (EPS)	Displays TBD
RTG	Displays TBD
Reactance Storage	Displays TBD
RTG Switch	Displays TBD

3.4.9.1.13 Environmental Control. -

<u>Control/Indicator</u>	<u>Function</u>
Suit Circuit Fan Select Switch	This switch shall select suit fans.
Coolant Pump Select Switch	This switch shall select pump No. 1, 2 or 3 and shall enable an automatic shutoff of a malfunctioning pump.
Water, O ₂ Quantity Monitor Switch	This switch shall indicate the quantity of water or gaseous oxygen in percent.
CO ₂ Partial Pressure Indicator	This indicator shall display carbon dioxide partial pressure of the atmospheric revitalization section.

GRUMMAN AIRCRAFT ENGINEERING CORPORATION

Bethpage, L. I., N. Y.
CODE IDENT 26512SPECIFICATION NO. ESP 13-0100

3.4.9.1.13 (Continued)

<u>Control/Indicator</u>	<u>Function</u>
Cabin Pressure Indicator Suit Pressure Indicator (Double Movement)	This indicator shall display cabin interior pressure or EMU suit pressure.
Cabin Temperature Indicator Suit Temperature Indicator (Double Movement)	This indicator shall display cabin temperature or EMU suit circuit temperature.
Gaseous Oxygen Pressure Indicator Water, O ₂ Quantity Meter (Double Movement)	This indicator shall display gaseous oxygen pressure or total water in descent tank.
Glycol Pressure Indicator Glycol Temperature Indicator (Double Movement)	This indicator shall display either the pressure or the temperature of the glycol coolant in both the primary and secondary heat transport loops.
CO ₂ Component Caution Light	This light shall indicate the CO ₂ status of the primary LiOH canister.
Water Separator Component Caution Light	This light shall indicate the failure status of the operating water separator.
Suit Circuit Fan Component Caution Light	This light shall indicate the failure status of the selected suit fan.
Glycol Pump Component Caution Lights	Each of two lights shall indicate the failure status of its respective glycol pump.

3.4.9.1.14 Subsystem Lighting. -

<u>Control/Indicator</u>	<u>Function</u>
Annunciator Numeric Brightness Control	This control shall vary the brightness of all component caution lights, annunciator, and EL numeric displays.

GRUMMAN AIRCRAFT ENGINEERING CORPORATION

Bethpage, L. I., N. Y.
CODE IDENT 26512**SPECIFICATION NO.** ESP 13-0100

3.4.9.1.14 (Continued)

<u>Control/Indicator</u>	<u>Function</u>
Integral Lighting Control	This control shall vary the brightness of the low level integral lighting.
Flood Lighting Control	This control shall regulate the brightness of the floodlights.
Commander's Side Panel Control and System Eng. Side Panel Control	This control shall make or break the circuits from the integral lighting control and the flood lighting control.
Dome Light Control	This control shall regulate the brightness of the dome light.
Exterior Lighting Control	This switch shall control the docking and tracking lights on the vehicle.
Three Override Toggle Switches	Displays TBD
Lamp Slant Tone Test Switch	Displays TBD
DSKY	GFE computer display keyboard.

3.4.9.1.15 Caution and Warning. -

<u>Control/Indicator</u>	<u>Function</u>
Caution and Warning Displays	These displays shall consist of two master alarm lights, an array of caution and warning indicators, and component caution lights.
Master Alarm Lights Master Alarm Tone	One aviation red master alarm light shall be an audible tone heard through the headphones in conjunction with the master alarm lights.

GRUMMAN AIRCRAFT ENGINEERING CORPORATION

Bethpage, L. I., N. Y.
CODE IDENT 26512SPECIFICATION NO. ESP 13-0100

3.4.9.1.15 (Continued)

<u>Control/Indicator</u>	<u>Function</u>
Warning Array	Shall be an array of no more than 20 aviation red-lighted legends, located near the top of panel I.
Caution Array	Shall be an array of no more than 20 aviation yellow-lighted legends, located near the top of panel II.
Component Caution Lights	Shall be located on the control and display panels to aid in location of a particular malfunction. The face of these caution lights shall be circular and of the press-to-test type.
Caution & Warning Lights Test Switch	This switch shall provide a test for the bulbs in all the lights of caution/warning, master alarm, audible tone, and engine start and stop override pushbutton.

3.4.9.1.16 Heater Controls. -

<u>Control/Indicator</u>	<u>Function</u>
3 Descent Battery Heater Switches	These heaters shall control heat of the descent batteries.
RCS Quad No. 1 Heater Switch	These switches shall be used to control temperature of the four RCS clusters.
RCS Quad No. 2 Heater Switch	
RCS Quad No. 3 Heater Switch	
RCS Quad No. 4 Heater Switch	
Temperature Monitor Select Switch	This 6-position rotary switch shall provide monitoring of the RCS quad temperature.

SPECIFICATION NO. ESP 13-0100

3.4.9.1.16 (Continued)

<u>Control/Indicator</u>	<u>Function</u>
Temperature Indicator	This indicator shall display the temperature, in degrees Fahrenheit, of the quad selected by switch 18-S-10.
Landing Radar Temperature Select Switch	This toggle selects the range of temperature control desired for the automatic heating of the landing radar antenna assembly.
Landing Radar Heater Switch	This switch controls the heater assembly of the landing radar system.

3.4.9.2 Design Requirements. - The design of controls and displays shall conform to the following requirements:

- (a) Display range and readout accuracy shall not exceed the needs of the flight crew to manage the vehicle. Scale markings shall not permit readout accuracies of a more precise nature than the accuracy of the input signal.
- (b) All controls essential to crew safety shall permit satisfactory operation by a flight crew in pressurized space suits. Such considerations as appropriate location, spacing, size, and torque shall be included in this operation.
- (c) Status indicators (flags or lights) shall be employed to indicate valve positions where such valves are actuated by inputs from momentary toggle switches.
- (d) Time shared displays of parameters shall be employed when such parameters need not be monitored continuously or concurrently.
- (e) Percentage readouts shall be employed where specific quantities are not required by the crew.
- (f) Where feasible dual meters of the fixed scale, moving pointer type shall utilize a single scale, appropriate for both parameters displayed, centered between two pointers.

SPECIFICATION NO. ESP 13-0100

3.4.9.2 (Continued)

- (g) Scale graduations shall progress by 1, 5 or 2 units, in that order of preference, or decimal multiples thereof only.
- (h) All scale markings shall be equally spaced. The use of non-linear scales shall be avoided, if possible.
- (i) Heights, widths, and spacing of all nomenclature shall be as close as feasible to the preferred dimensions established by human engineering considerations. In no case shall these dimensions be smaller than the acceptable minimum established by these same considerations.
- (j) Abstract symbols and abbreviations shall not be used unless they are easily understood by the crew. A minimum of two letters shall be required when any abbreviation is employed and shall be standard between modules.
- (k) Interruption of power to any display shall be made immediately apparent to the crew.
- (l) Maximum torque, which is required of the flight crew for small valve control handles, shall not exceed 10 inch-lbs. A small valve control handle shall not exceed 2.25 inches in diameter and shall be the faucet type.
- (m) Where 20-30 inch-lbs control torques are required, control handles shall be not less than 3 inches in length.
- (n) Controls or displays shall be designed to avoid blind actuation by the flight crew.

3.4.10 Explosive Devices Subsystem (EDS). - The EDS shall consist of explosive devices and related components necessary to initiate and control the functions specified in 3.4.10.1.

3.4.10.1 Performance Requirements. - The EDS shall initiate and control the following functions:

- (a) Environmental Control Subsystem (ECS) water valve opening
- (b) Reaction Control Subsystem (RCS) pressurization

SPECIFICATION NO. ESP 13-0100

3.4.10.1 (Continued)

- (c) Landing gear deployment
- (d) Descent propulsion subsystem pressurization
- (e) Descent propulsion vent valve opening
- (f) Top hatch cover deployment

3.4.10.2 Design Requirements. - Electrical wiring from the Shelter/CM interface to the Shelter/Spacecraft LEM Adapter (SLA) shall be provided through the Shelter to conduct the signal for SLA/Shelter separation.

3.4.10.2.1 Power Supplies. -

3.4.10.2.1.1 Logic Power. - Logic d-c power shall be supplied by the system engineer bus and commander bus in the ascent stage. Explosive device power shall be controlled by a manual switch.

3.4.10.2.1.2 Transient Power Characteristics. -

- (a) The subsystem shall cause no transients under any conditions as specified below:
 - (1) Signal duration or signal interruption of greater than 10 microseconds and voltage variation greater than plus or minus 2 volts.
 - (2) Signal duration sufficient to fire a standard pyrotechnic device.
- (b) The subsystem shall operate satisfactorily when the logic bus voltage is maintained between 25 and 36.5 volts and with no logic bus voltage interruption greater than 500 microseconds during any 20 millisecond period.

SPECIFICATION NO. ESP 13-0100

3.4.10.2.1.3 Explosive Devices Power. - The electrical power for the firing of explosive devices shall be supplied by two silver-oxide-zinc batteries in the descent stage.

- (a) Battery Voltage - Open-circuit voltage shall be a maximum 37.8 volts. Nominal voltage shall be 23 volts while delivering 75 amperes. When the battery is completely discharged after delivering 75 amperes, the final voltage shall be 20 volts.
- (b) Battery Capacity - The battery shall be capable of delivering a current of 75 amperes for 36 seconds down to a final voltage of 20 volts during the first six cycles of discharge.
- (c) Battery Service Life. - The total number of complete cycles of discharge and recharge within the 60 to 100 degrees Fahrenheit temperature range shall be a minimum of six cycles.

3.4.10.2.2 Circuitry. -

- (a) Circuit Protection - Circuit protection for the EDS shall be provided by a system of high reliability circuit breakers and current limiting fuses.
 - (1) Circuit breakers shall be provided as follows:
 - a. To clear the logic busses of ground faults in the EDS.
 - b. To protect wiring from deterioration (including production of smoke or toxic fumes in the ascent stage cabin) caused by faults or overloads.
 - (2) Fused resistors shall be provided to limit current drain on the ED batteries due to vehicle wiring or ED firing circuit.
- (b) Explosive Device Circuits - Explosive device circuits shall be the only electrical load connected to the explosive device power bus and shall not be powered from the logic bus.
- (c) Isolation - Explosive device circuits and logic circuits shall be electrically and physically isolated from one another and their wiring shall be routed separately where possible.

SPECIFICATION N.O.: ESP 13-0100

3.4.10.2.2 (Continued)

- (d) Grounds and Returns - The ED circuits shall not be grounded. The logic and instrumentation circuit ground returns shall be separate and shall in no way cause the ED circuit to become grounded.
- (e) Shields - Firing circuit shields shall be electrically continuous with no physical discontinuities and grounding shall be consistent with the requirements of AFMTCP 80-2, General Range Safety Plan.
- (f) Operational Assurance - To assure operation of all functions controlled by the EDS, the design shall be "fail safe" in all respects. The EDS shall consist of two independent circuits to provide redundancy. There shall be no electrical or mechanical crossovers except for the common mechanical actuation of control switches. A single failure shall not be cause for function failure or mission abort.
- (g) Redundant Wiring - Redundant internal wiring shall be used where a loss of a single lead would cause premature initiation of a major function or loss of control of the function.
- (h) Timing - Timing requirements shall be held within plus or minus 5 percent maximum under all conditions specified herein.
- (i) Time Delays - Time delays shall be arranged to minimize the possibility of function initiation occurring before the termination of the specified time delay.
- (j) Transients - See paragraph 3.4.10.2.1.2.2.
- (k) Explosive Devices Shorting - The controller fire relay shall maintain a shunt across each explosive device circuit prior to firing. The firing circuit operation shall simultaneously remove this shunt and provide ED initiation. The shunt resistance shall be 2.5 ohms maximum.
- (l) Manual Capability - Manual capability shall be provided for selected functions as specified herein.

SPECIFICATION NO. ESP 13-0100

3.4.10.2.3 Explosive Device Requirements. - The modular concept shall be used in the design of all explosive devices and assemblies. Explosive charge assemblies of all types shall be separate from higher assemblies and from structural elements. Devices containing an integral Apollo Standard Initiator (ASI) and which would by their own energy or by initiating a chain of events, cause injury to people or damage to property, shall be capable of installation on the launch pad. Explosive devices having unique applications shall be designed to preclude mis-installation. Threaded cartridges having different output characteristics shall have different thread sizes. All high explosive charges such as a mild detonating fuse (MDF), shall be mounted in suitable charge holders which are separable from structural elements. Charge holders shall be designed to protect the explosive trains, to minimize and direct backblast, and to permit ease of installation at the launch site. The explosive charge shall be sealed from exposure to atmospheric and mission environments. Explosive trains consisting of more than one integrally assembled component shall have booster interfaces.

3.4.10.2.4 Explosive Devices. - The following explosive devices separately or in various combinations shall accomplish the previously specified functions.

- (a) Apollo Standard Initiator (ASI) - The ASI shall initiate all electrically actuated explosive functions required during the Shelter mission. This device is common usage with NAA.
- (b) Apollo Standard Detonator (ASD) - The ASD shall be used to detonate all high explosive charges in the Shelter. This device is common usage with NAA.
- (c) Mild Detonating Fuse (MDF) - The MDF shall be common usage with NAA.
- (d) ECS Water Valve - The ECS water valve shall be actuated by one or both of the two ASI's installed.
- (e) RCS Helium Pressurization - The RCS explosive valve shall be actuated by the single ASI installed.

SPECIFICATION NO. ESP 13-0100

3.4.10.2.4

(Continued)

- (f) Descent Engine Helium/Propellant Venting Valve - The venting explosive valves shall be actuated by one or both of the two ASI's installed.
- (g) Descent Propulsion Subsystem Pressurization Valve - The (DPS) explosive valves shall be actuated by one or both of the two ASI's installed.
- (h) Landing Gear Uplock - Each landing gear leg shall be secured in the retracted position by a single restraining device. This device shall have turn buckle type tension and preloading capability. It shall have a dual initiation mode either of which is capable of actuating the device. The device shall separate into two parts to release the landing gear. No parts shall be unattached after release.
- (i) Circuit Interrupter - Circuit interrupters shall be provided to terminate all signal and power leads running between the ascent and descent stages which are live at time of separation or which could subsequently become live due to activation of a circuit. These devices shall be initiated explosively approximately 10 milliseconds after stage command is received. They shall be actuated by either of the two ASI's.
- (j) Top Hatch Cover - The top hatch cover shall be secured in the retracted position by means of a single clamp. The clamp shall be fastened by two explosive bolts. The firing of either explosive bolt shall be capable of releasing the hatch cover.

SPECIFICATION NO. ESP 13-0100**4 QUALITY ASSURANCE PROVISIONS**

4.1 Quality Program. - A Grumman quality program shall be established in accordance with NASA Publication NPC 200-2. The quality program shall provide the general requirements necessary to ensure that the vehicle meets the quality requirements of the contract. These requirements shall include the establishment and maintenance of an effective quality program from the design conception to the delivery of a vehicle.

4.1.1 Identification and Traceability. - The quality program shall provide for identification and traceability control.

4.2 Reliability Program. - A Grumman reliability program shall be established in accordance with NASA Reliability Publication NPC 250-1.

4.3 Tests. -

4.3.1 Development Tests. - The development tests shall be as specified in 4.3.1.1 and 4.3.1.2.

4.3.1.1 Design Feasibility Tests. - Design feasibility tests shall be conducted for all new equipment and to that LEM equipment that has been redesigned or modified to the extent that performance or safety strength margins under selected environments are now in doubt. The tests shall be conducted to:

- (a) Achieve component and part selection.
- (b) Investigate the performance of breadboard models, components and subassemblies under selected environmental conditions.
- (c) Substantiate safety/strength margins and analytical assumptions.

4.3.1.2 Design Verification Tests. - Design verification tests shall be conducted for all new equipment and to that LEM equipment that has been redesigned or modified in order to verify the optimum design characteristics prior to qualification testing. These tests shall include all those conducted to substantiate the correctness of the design for its intended mission under simulated ground and flight environments and off design conditions.

SPECIFICATION NO. ESP-13-0100

4.3.1.2.1 Required Tests. - As a culmination to design verification, the specified vehicle equipments shall be subjected to the critical environments of an operational cycle followed by an overstress test. These tests shall fulfill the following essentials:

- (a) The tests shall be performed on production equipment.
- (b) Successful completion of these tests except overstressed tests shall be a prerequisite to the start of qualification tests. Completion of overstress tests shall precede the completion of qualification tests.
- (c) No failure, replacement of parts, maintenance or adjustments shall be permitted during the critical environments tests, except those adjustments which are included as part of the normal operations of the equipment under test.

4.3.1.2.1.1 Critical Environmental Tests. - The specified equipments shall be successfully subjected to the critical environments of an operational cycle. The critical environments shall be at mission levels. An operational cycle shall consist of all the environments and dynamic conditions to which the equipment will be exposed during the acceptance tests, handling, transportation and storage, prelaunch, launch, translunar, and lunar phases of the vehicle mission. Equipment subject to particular environments shall be subjected to applicable critical environmental tests.

4.3.1.2.1.2 Overstress Tests. - At the completion of the critical environmental tests, the equipment shall be tested to failure under systematically increasing dynamic and environmental stresses. Deviation of performance from the minimum acceptable operating mode shall constitute a failure. The equipment shall dwell long enough at each increment of overstress to stabilize conditions and complete an abbreviated operational test.

4.3.1.2.1.2.1 Selection of Stresses. - A failure mode prediction analysis shall provide the basis for the selection of critical stresses to be employed in the overstress tests. Only conditions from the launch and post-launch phase of the mission shall be used for the overstress tests. If the critical mission stresses are due to a combination of dynamic and environmental conditions, the tests shall be performed under that combination of environments. If the critical stresses are due to several dynamic and

SPECIFICATION NO. ESP 13-0100

4.3.1.2.1.2.1 (Continued)

environmental conditions which are not in combination in the mission, the test increments shall be performed with each condition imposed separately. Each increment of the test conditions shall be increased in proportion to their values at mission levels.

4.3.1.2.1.3 Analysis of Results. - An engineering analysis of the data generated by the overstress tests, including a correlation with the failure mode prediction analysis, shall be performed.

4.3.2 Qualification Tests. - Qualification tests shall be performed in compliance with the requirements of NASA Quality Publication NPC 200-2. Qualification tests of parts, components, subassemblies and higher levels of assembly shall be performed to demonstrate that the vehicle is capable of meeting the requirements specified in the individual End Item specification. Qualification tests shall be performed on two production equipments. One equipment shall be used for design limit tests and the other equipment shall be used for endurance tests. A qualification endurance test shall be performed on a selective basis on only those equipments identified for endurance testing as the result of analysis.

4.3.2.1 Qualification Testing Requirements. -

4.3.2.1.1 Applicability. - The qualification tests shall start at the lower levels of assembly and proceed to levels of higher assembly. As a general rule, it is not economically practical or feasible to conduct qualification tests on complete subsystems. Accordingly, most of the qualification tests shall be conducted on lower levels of assemblies to the degree necessary to provide confidence on a subsystem basis. This will be done by conducting tests at hardware levels such that when the total qualification program on a subsystem is completed all items of hardware and all operational modes will, as a minimum, be tested to an amount equivalent to a subsystem qualification test.

4.3.2.1.2 Purpose. - Qualification tests shall be designed to:

- (a) Locate significant failure modes.
- (b) Determine the effects of varied stress levels.
- (c) Determine the effects of combinations of tolerances and drift of design parameters, and

SPECIFICATION NO. ESP 13-0100

4.3.2.1.2 (Continued)

(d) Determine the effects of applicable combinations and sequences of environments and stress levels.

4.3.2.1.3 Environments. - Qualification testing shall include both natural and induced environments. Combined environments shall be used when applicable.

4.3.2.1.3.1 Qualification Criteria for Environments. -

4.3.2.1.3.1.1 Criteria for Imposing Environment. - The criteria for imposing environments during qualification testing shall be based on the concept that all vehicle equipment shall demonstrate their capability to withstand the worst case operational cycle environments, both natural and induced.

4.3.2.1.3.1.2 Natural Environments. - All natural environments shall be considered for inclusion such as: humidity, salt spray, rain, sand and dust, fungus, ozone, solar radiation, and pressure/vacuum.

4.3.2.1.3.1.3 Induced Environments. - All induced environments shall be considered for inclusion such as: acceleration, acoustics, shock, vibration, high temperature, low temperature, pressure/vacuum, oxygen, cabin contaminants (salt and humidity), and EMI/RFI.

4.3.2.1.3.1.4 Environmental Levels. - The environmental levels shall be derived from the most severe conditions that may be imposed during an operational cycle and shall be as defined in 3.1.2.4 and 3.1.2.8.

4.3.2.1.3.1.5 Testing. - Testing shall be performed on those equipments that have an inherent sensitivity to the particular environment. The sensitivity shall be based upon the item failure modes and the effects of the environment upon its endurance, strength, and operational characteristics.

4.3.2.1.3.1.6 Sensitivity. - If the sensitivity of the equipment to a particular environment cannot be positively determined, then the equipment shall be subjected to testing to that environment.

SPECIFICATION NO. ESP 13-0100

4.3.2.1.3.1.7 Particular Environment. - Testing to a particular environment may be waived when analysis demonstrates that the environmental level is reduced through reliable protective measures to a point where it is insignificant or where the inherent strength or design characteristic of the equipment renders it insensitive to the specified environmental level.

4.3.2.1.3.1.8 Sequence. - The sequence in which the environments shall be imposed during testing shall be as outlined below except that tests shall be planned to minimize the number of test set-ups, providing the test objectives are not severely compromised. Tests shall avoid facility and special test equipment overlap.

- (a) For endurance qualification, environments shall be imposed in the same sequence that will be experienced during a normal operational cycle.
- (b) For design limit qualification, the sequence shall be based upon its possibility of occurrence, the severity of the degradation effects and inter-reaction effects, where known. The most critical environments shall be imposed first.

4.3.2.1.4 Program Design. - In determining the number of equipments required for qualification, all prior development tests including integrated ground tests shall be considered. Portions of the development tests may be used to reduce the qualification tests required provided all qualification test requirements are met and prior NASA approval is obtained. Where redundancy in design exists, the qualification tests shall assure that each redundant component and mode will be included in the test program. Qualification test procedures and criteria shall be specified for each equipment which will undergo qualification testing, and the qualification tests will fully encompass the design requirements specified for that equipment.

4.3.2.1.5 Schedule. - Qualification tests supporting a particular flight vehicle shall be completed prior to that vehicle being delivered by the contractor.

4.3.2.1.6 Qualification Basis. - The minimum qualification shall include one set of equipment subjected to sequential, singly applied environments at design limit conditions (Design Limit Test), and another set subjected to one operational cycle and one subsequent mission cycle at nominal mission conditions (Endurance Test).

SPECIFICATION NO. ESP 13-0100

4.3.2.1.6.1 Qualification by Similarity. - Qualification by similarity may be accepted provided the following criteria are satisfied:

- (a) The equipment was qualified to environmental test requirements that meet or exceed those specified for the Shelter.
- (b) The equipment was fabricated by the same manufacturer with the same methods or processes and quality control.
- (c) The equipment was designed to specifications that satisfy all the requirements set forth for that item in Shelter specifications.

4.3.2.1.6.2 Requalification. - Requalification shall be performed when:

- (a) Design or manufacturing processes are changed to the extent that the original tests are invalidated.
- (b) Inspection, test, or other data indicate that a more severe environment or operational condition exists than that to which the equipment was originally qualified.
- (c) Manufacturing source is changed.

4.3.2.1.7 Procedures. -

- (a) Acceptance test shall precede all qualification tests.
- (b) Functional operation shall be required as applicable. During all qualification tests all interfaces shall be present or simulated.
- (c) Adjustments shall be permitted during an operational cycle only if they are part of a normal procedure.
- (d) Limited life items and single-shot devices may be replaced at the completion of satisfactory operation through their life requirement.

SPECIFICATION NO. ESP 13-0100

4.3.2.1.7 (Continued)

- (e) Any failure shall be cause for positive corrective action. The degree of retest in event of failure shall be agreed upon between the NASA and the contractor after evaluation of the failure. In the event of failure, the contractor shall immediately notify NASA.

4.3.2.1.8 Additional Testing. - Subsequent to the completion of the qualification tests further tests shall be conducted at conditions more severe than design limit. The purpose of these tests shall be to determine failure modes and actual design margins.

4.3.2.2 Design Limit Tests. - (To be determined)

4.3.2.3 Endurance Tests. - The second equipment shall be successfully subjected to the conditions of a complete operational cycle plus the conditions of the flight simulation phase of an operational cycle at mission levels.

4.3.2.4 Post-Qualification Tests. - At the completion of the qualification tests, the test units shall be subjected to the tests specified in 4.3.2.4.1 and 4.3.2.4.2 in order to increase confidence in equipment design life and strength. These tests shall be run on qualified equipment.

4.3.2.4.1 Overstress Tests. - The post-qualification testing of the design limit test unit shall consist of overstress tests in the same mode or condition as selected for the design verification overstress test (4.3.1.2.1.2), unless results of previous testing indicates otherwise.

4.3.2.4.2 Flight Simulation. - The post qualification testing of the endurance test unit shall consist of two additional flight simulations.

4.3.3 Test at Higher Levels. - Grumman uses the terms "flight ready" and "flight release" rather than "qualified" and "qualification" to describe subsystems test and higher level test to avoid confusion with the

SPECIFICATION NO. ESP 13-0100

4.3.3 (Continued)

generally accepted definition of qualification. Flight release does not connote demonstration of all Shelter development requirements but only those associated with a specific flight. The ground test program proceeds through a series of logical steps to verify, within constraints, that the Shelter will fulfill test requirements. These constraints are such that complete verification requires a test flight buildup before the mission is attempted. The successful completion of each ground or flight test (except the last) releases a constraint on a subsequent test. At a point specified in the ground or flight plan, subsystems will be ranked as "flight ready" for a specific flight.

4.3.4 Acceptance Test. - Acceptance tests shall demonstrate that the equipment is representative of that equipment used in the qualification tests. Acceptance test conditions shall not be more severe than expected flight conditions and shall include factors of safety and margins of life. Contract end-item test is equivalent to an acceptance test.

4.3.4.1 Applicability. - Acceptance testing shall include all inspections and tests which are used as a basis for acceptance by the contractor. It may include tests on parts, components or subsystems. These requirements shall apply to the acceptance of hardware by the contractor from the subcontractors and to the acceptance of in-house produced hardware by the prime contractor.

4.3.4.2 Program Design. -

- (a) Acceptance tests shall be performed on the equipment prior to delivery or upon completion of in-house manufacture.
- (b) Acceptance tests of equipment are to be technically integrated with the manufacturing tests and the vehicle checkout so that the total program is designed to provide assurance that each contract end-item is capable of fulfilling its required end-use.
- (c) Acceptance testing shall include functional tests, environmental exposures as required, and inspection techniques designed to:
 - (1) Locate manufacturing defects
 - (2) Locate handling damage

SPECIFICATION NO. ESP 13-0100

4.3.4.2 (Continued)

(c) (Continued)

(3) Provide assurance that no malfunction exists prior to shipping.

(4) Provide assurance that equipments conform to their performance specification and other approved performance criteria.

(d) Acceptance testing may include calibration or alignment or both.

(e) The degree, duration, and number of tests and checks shall be sufficient to provide assurance that each equipment possesses the required quality and performance without degradation to the item.

4.3.4.3 Procedure. -

(a) Selection of the acceptance test and checkout procedures shall be based upon the performance requirements of the item.

(b) Where possible, without degradation or destruction of the equipment, all normal, alternate, redundant, and emergency operational modes shall be demonstrated.

(c) The functional tests shall simulate end-use to the highest degree practicable without degradation of the operational or life characteristics of the item. Sampling plans may be employed when the tests are destructive or when the classification, characteristics, records, or non-critical application of the item indicates that less testing is required.

(d) If calibration of the equipment is necessary, then calibration and alignment shall be performed on the equipment in order to detect and adjust any variation in its accuracy prior to test. No adjustments shall be made during the performance of the test unless it represents a normal operating procedure.

SPECIFICATION NO. ESP 13-0100

4.3.4.3 (Continued)

- (e) Final inspection techniques shall include visual examination, measurements, non-destructive tests, and special procedures such as x-ray, infrared, ultrasonics, and optical alignment where required.

4.3.4.4 Environments. -

- (a) Each item shall be subjected to only those environmental tests necessary to reveal defects without overstressing or degradation.
- (b) Selection of the environments and stress levels shall be based upon design specifications or end use requirements or both, and if available, the results of development and qualification tests may be used to modify these environments or stress levels.
- (c) Environmental exposure shall be limited to the acceptance testing following manufacturing. Exposure to environments in excess of those specified for acceptance testing shall be cause for rejection.

4.3.4.5 Acceptance Basis. -

- (a) The acceptance of each item shall be determined by a comparison between the acceptance test results and the applicable specification requirements.
- (b) After completion of tests and inspections, execution of any repairs, modifications, or replacements shall necessitate a reinspection and retest to assure the acceptability of the change and its effects on related equipment. The extent of retest shall be determined jointly by the contractor and NASA or their delegated representatives.

4.3.4.6 Test Equipment. - The contractor shall provide for the selection, evaluation, approval, maintenance, and control of all inspection standards, gages, measuring and test equipment necessary to determine conformance with specification, drawing, and contract requirements.

GRUMMAN AIRCRAFT ENGINEERING CORPORATION

Bethpage, L. I., N. Y.
CODE IDENT 26512

SPECIFICATION NO. ESP 13-0100

4.3.5 Formal Engineering Acceptance Test (FEAT). - A formal engineering acceptance test will be performed on the vehicle prior to shipment, using ACE and other associated equipment, to verify compliance of operational and performance parameters with design requirements.

4.3.6 Electromagnetic Interference Test. - A test program to verify compliance to requirements imposed by paragraph 3.3.9 shall be conducted at all levels through the entire test program.

5 PREPARATION FOR DELIVERY

5.1 Preservation and Packaging. - Individual deliverable items shall be preserved and packaged for the maximum anticipated storage life. Preservation and packaging, in accordance with Grumman Specification LSP-14-009, shall maintain the cleanliness level established.

5.2 Packing. - Individual deliverable items shall be packed to withstand the selected mode of transportation and handling.

6 NOTES

GRUMMAN AIRCRAFT ENGINEERING CORPORATION

Bethpage, L. I., N. Y.
CODE IDENT 26512

SPECIFICATION NO. ESP. 13-0100

10 APPENDIX (TBD)

~~CONFIDENTIAL~~



Grumman Aircraft Engineering Corporation • Bethpage, New York

~~CONFIDENTIAL~~