



Available online at www.sciencedirect.com

SCIENCE @ DIRECT®

Consciousness and Cognition 12 (2003) 633–646

Consciousness
and
Cognition

www.elsevier.com/locate/concog

Emergence of self and other in perception and action: An event-control approach

J. Scott Jordan*

Department of Psychology, Illinois State University, Campus Box 4620, Normal, IL 61790-4620, USA

Received 27 February 2003

Abstract

The present paper analyzes the regularities referred to via the concept ‘self.’ This is important, for cognitive science traditionally models the self as a cognitive mediator between perceptual inputs and behavioral outputs. This leads to the assertion that the self causes action. Recent findings in social psychology indicate this is not the case and, as a consequence, certain cognitive scientists model the self as being epiphenomenal. In contrast, the present paper proposes an alternative approach (i.e., the event-control approach) that is based on recently discovered regularities between perception and action. Specifically, these regularities indicate that perception and action planning utilize common neural resources. This leads to a coupling of perception, planning, and action in which the first two constitute aspects of a single system (i.e., the distal-event system) that is able to pre-specify and detect distal events. This distal-event system is then coupled with action (i.e., effector-control systems) in a constraining, as opposed to ‘causal’ manner. This model has implications for how we conceptualize the manner in which one infers the intentions of another, anticipates the intentions of another, and possibly even experiences another. In conclusion, it is argued that it may be possible to map the concept ‘self’ onto the regularities referred to in the event-control model, not in order to reify ‘the self’ as a causal mechanism, but to demonstrate its status as a useful concept that refers to regularities that are part of the natural order.

© 2003 Elsevier Inc. All rights reserved.

1. Introduction

An examination of the relationship between concepts such as ‘self’ and ‘action’ quickly reveals the unique manner in which cognitive science has developed its conceptual scheme. Whereas other

* Fax: 1-309-438-5789.

E-mail address: jsjorda@ilstu.edu.

areas of science such as physics, chemistry and biology tend to map concepts (e.g., mitochondria, polymers, and quarks) onto discovered regularities, cognitive science tends to map discovered regularities onto folk-psychological concepts. As the number of discovered regularities in cognitive systems continues to increase however, concise one-to-one mappings prove increasingly difficult to achieve. As a result, the meaning of concepts such as ‘self’ get stretched to such an extent that cognitive scientists find themselves in disagreement over issues such as whether or not the ‘self’ is efficacious (Wegner, 2003), whether or not ‘goals’ exist (Metzinger & Gallese, 2003), and/or where in the brain the ‘self’ and ‘other’ might be represented (Decety & Chaminade, 2003).

In light of this conceptual ambiguity, the purpose of the present paper is to examine the regularities cognitive scientists traditionally refer to via the concept ‘self.’ The first part of this analysis will reveal that within the traditional cognitive framework, the concept ‘self’ does not fare very well and is ultimately regarded as an epiphenomenon. In the second part I propose that the demise of the concept ‘self’ may derive from cognitive science’s commitment to a folk-psychological conceptualization of perception and action in which the two are fundamentally modeled as ‘seeing’ and ‘doing,’ respectively. In the final section I propose an alternative approach that addresses this commitment to ‘seeing’ and ‘doing’ by focusing on regularities that have been recently discovered, as well as some that have been simply overlooked. In the end, the goal is to determine which regularities, if any, might successfully map onto the concept ‘self.’ This is not an ontological question. I am not attempting to determine whether or not the ‘self’ is a causal mechanism. Rather, I am attempting to determine whether or not there are any regularities the concept ‘self’ might map onto. If the answer proves to be yes, then it becomes unclear to what extent the notion of the ‘self’ as an epiphenomenon can, in fact, be true.

2. Regularities and the traditional cognitive framework

In the framework of traditional cognitive science, psychological systems are divided into functionally orthogonal halves; perception is an input function, action is an output function (Jordan, *in press*). Within this partitioning, the self is modeled as a pre-specifying/monitoring function that mediates between the two, and is referred to via terms such as ‘executive function’ and ‘central executive.’ This proposed function appeals to regularities entailed in both the first and third person perspective. As regards the first person perspective, the concept ‘self’ is often used to refer to regularities entailed in our phenomenal sense of agency. Wegner (2002) has examined these regularities extensively and discovered they are, in principle, the same as those underlying our third person use of the term ‘causality.’ Specifically, Wegner proposes that the regularities entailed in our phenomenal experience of agency (what he refers to as ‘will’) are Priority (an action must be preceded by a thought—i.e., pre-specified), Consistency (the thought must be consistent with the action), and Exclusivity (the action must have no other attributable cause). Thus, one ‘experiences’ oneself as having ‘caused’ an action to the degree the conditions of Priority, Consistency, and Exclusivity are met. Actions not accompanied by these conditions are not ‘felt’ to have been ‘caused’ by oneself. The concept ‘self’ then, is used in Wegner’s model to refer to regularities in phenomenology (i.e., first person experience).

As regards the third person perspective, the concept ‘self’ is used in traditional models to refer to regularities produced by others. According to the traditional account, the third person

perspective grants us access to regularities in another's actions. From these perceived (i.e., seen) limb patterns, we then generate cognitive inferences about intentions (Barresi & Moore, 1996; Premack & Woodruff, 1978). The concept 'self' then, when referring to another, is reserved for pre-specifying/monitoring functions internal to the other, that are assumed to mediate between the other's perceptions and actions.

At first glance, such an approach grants a lot of efficacy to the self because it models it as a mechanism that has the function of selecting and initiating (i.e., causing) one's actions. When social psychologists apply this model to their data however, they find that most if not all differences in behavior can be accounted for via externally caused automatic processes (Bargh & Chartrand, 1999; Wegner, 2002; Wegner & Wheatley, 1999), as opposed to conscious control (i.e., self) processes. Research by Bargh, Chen, and Burrows (1996) for example, indicates that subliminal stereotype activation produces increases in hostile behavior, and research by Chen and Bargh (1997) indicates such subliminal activation can lead one to unconsciously elicit increased hostility in another. In both of these cases, the 'self' does not seem to be involved in the selection of one's behaviors at all. Based on findings such as these, as well as others, Wegner (2002) argues that the experience of a causal self (i.e., a Will) may be an illusion. According to this account, behaviors are selected by unconscious automatic-processes (Shiffrin & Schneider, 1977), and the regularities in one's phenomenal sense of self constitute epiphenomena.

3. An alternative: The event-control approach

Lying at the core of the assertion that the 'self' is epiphenomenal, at least as regards one's actions, is the assumption that while the 'self' is folk-psychological concept that cognitive scientists have conceptualized incorrectly, 'perception' and 'action' are not. In other words, by explicitly asserting that actions are caused by automatic perceptual processes, one implicitly asserts the functional orthogonality between perception and action inherent in traditional cognitive models. Perception then, is an input function that maps directly onto the folk-psychological notion of 'seeing,' while action is an output function that maps directly onto the folk-psychological notion of 'doing.' The problem is, more and more data indicate that perception and action are not coupled in this manner.

Neurophysiological findings obtained over the last decade indicate that perception and action-planning share common neural mechanisms. Examples include the 'visual-and-motor neurons' (e.g., Taira, Mine, Georgopoulos, Murata, & Sakata, 1990) found in monkey parietal cortex, and the 'mirror neurons' (e.g., Di Pellegrino, Fadiga, Fogassi, Gallese, & Rizzolatti, 1992) located in the premotor cortex. Mirror neurons become active when a monkey both performs a given action and observes a similar action performed by an experimenter (Di Pellegrino et al., 1992; Rizzolatti, Fadiga, Fogassi, & Gallese, 2002). These findings point to populations of neurons that are involved in the *detection* and *specification* of distal events. In short, they are involved in both perception and planning.

Research in cognitive psychology also supports this idea. The Theory of Event Coding (Hommel, Müsseler, Aschersleben, & Prinz, 2001; Prinz, 1992, 1997) for example, asserts that perception and action planning share resources, and that both take place in a distal frame of reference. As a result, action plans refer to *distal events*, not limb movements, and generating a

plan alters perception and its relationship to one's actions. Support for this theory derives from studies in which subjects are asked to identify the spatial value (i.e., left or right) of a briefly presented arrow stimulus that is presented while subjects plan either a left or right button press (for an overview see Müsseler & Wühr, 2001). These studies indicate that subjects are better able to identify the direction of the arrow stimulus if it is presented alone, as opposed to being presented in the midst of an action plan. Further, if presented during an action plan (i.e., make a right or left button press), stimulus identification is better when the direction of the stimulus arrow is opposite that of the planned action (e.g., left-pointing stimulus arrow presented during the planning of a right key-press).

Collectively, these neurophysiological and cognitive-behavioral findings support the assertion that the systems used to specify distal events (i.e., what we commonly call action planning) share resources with those used to detect such events (i.e., what we commonly call perception). Given this dual functionality, one might propose a coupling of perception and action in which the perception/planning system is modeled as a *distal-event* system. In what follows, I describe a series of experiments that was motivated by this model and was designed to investigate how a distal-event system might be coupled with action.

3.1. *Spatial-perception, spatial-action, and event control*

It has been known for some time that if subjects are asked to indicate the vanishing point of a moving stimulus, the perceived vanishing point is displaced beyond the actual vanishing to an extent that varies directly with stimulus velocity (Hubbard, 1995). Kerzel, Jordan, and Müesseler (2001) found that if participants are allowed to track the moving stimulus via eye movements (i.e., the Pursuit condition), the usual displacement beyond the vanishing point obtains. If however, they are asked to fixate a non-moving stimulus during the presentation of the moving stimulus (i.e., the Fixation condition), the perceived final location is not displaced. Jordan, Stork, Knuf, Kerzel, and Müsseler (2002) found that these action-related differences are due to the *effect* one plans in relation to the moving stimulus, not the actions used to attain the planned effect. Specifically, they replicated the Fixation condition of the Kerzel et al. study, save for the following: (1) the stimulus trajectory was circular (i.e., around the fixation point) as opposed to linear, and (2) the disappearance of the stimulus was produced by the participants via a button press. If participants were instructed to press the button in order to make the moving stimulus vanish (i.e., the Intention condition), the perceived vanishing point was not displaced, regardless of stimulus velocity. If however, they were instructed to press the button in response to the onset of the moving stimulus (i.e., the Cue condition), the perceived vanishing point was located *behind* the actual vanishing point in the direction of the stimulus' initial position, and the magnitude of the displacement did not vary with velocity.

These data are rather consistent with the notion that perception and action-planning share resources, for in both conditions the perceived vanishing point was attracted to the stimulus location specified in the action plan (i.e., the final and initial positions in the Intention and Cue conditions, respectively), despite the fact participants produced the same actions in both conditions (i.e., fixated centrally and produced a button press). This suggests an alternative approach to coupling of perception and planning, for though the traditional approach makes strong distinctions between the two, these data indicate the two are, to some extent, entailed in the same

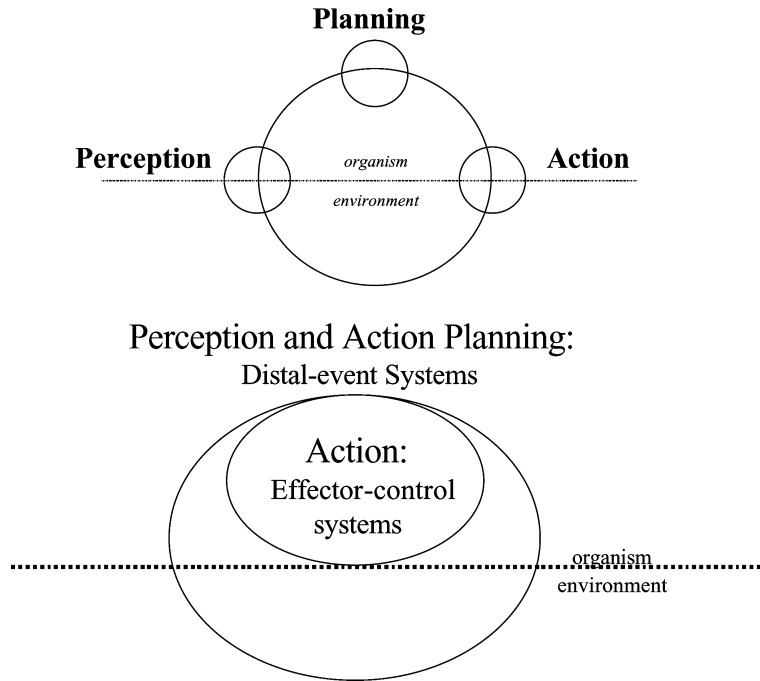

Fig. 1. (Top) Traditional coupling of perception, planning, and action in cognitive systems. Perception and action constitute functionally orthogonal halves of the organism, with the former serving an input function and the latter, an output function. (Bottom) Coupling of perception, planning, and action according to the notion of event control. Perception and action planning share common resources and are both inherently distal. The two are coupled with action as synergistically coupled control loops, with the distal-event system having the ability to constrain, as opposed to cause, effector-control systems (i.e., action).

process—the *distal-event* system. This also leads to a different approach to the coupling of ‘planning’ and ‘action,’ for what the distal-event system specifies in this model is not action (i.e., limb movement), but rather, the distal event that limb movements are to produce. This suggests that planning and action are coupled more in terms of ‘constraint’ than in terms of ‘cause.’ In other words, the distal-event system does not cause actions via direct causal links. Rather, the distal-event system constrains the distal events towards which effector-control systems (i.e., actions) are directed. Described in this fashion, psychological concepts (i.e., perception, self, and action) find themselves mapped onto synergistically coupled control loops rather than functionally independent aspects of a single loop (see Fig. 1).

3.2. Neurophysiology and event control

Though this approach to coupling may sound new, it has actually been alluded to implicitly in the neurophysiological community for some time. Fig. 2 represents the neuroanatomical organization of what is commonly referred to as the motor-control hierarchy. In this model, the function of the association cortex is to pre-specify a distal event the system is to achieve. The model illustrates the following (1) limb movements are controlled predominately via spinal/cerebellar

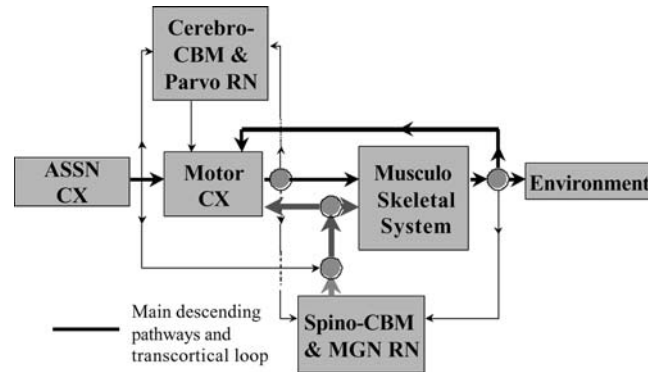

Fig. 2. The motor control hierarchy.

feedback loops, and (2) via the network's recursive architecture, the association cortex is able to 'constrain' (i.e., not 'cause') the activity of these lower level loops. Actual limb movements therefore, are 'caused' (i.e., controlled) via lower level loops. Rather, via the recursive nature of the network's architecture, the association cortex is able to 'constrain' the activity of the motor cortex, but the actual limb movements themselves are 'caused' (i.e., controlled) by lower level loops. This is consistent with the notion that the distal-event system 'constrains' actions but does not 'cause' them. If one starts to lose one's balance, the distal-event system does not regain the balance. Rather, the distal-event system detects an unexpected change in one's relationship to the environment, and the lower level control loops actually do the work of offsetting disturbances to balance.

Additional support for the notion of 'constraining' versus 'causing' action derives from recent findings that indicate there are several other systems that have access to motor cortex (Clark, 2001; Rossetti & Pisella, 2001). Thus, at the same time the distal-event system is modulating and constraining activity in the motor cortex, a host of other systems are doing the same. The limb patterns that ultimately emerge from this dynamic interaction therefore, cannot be attributed to one particular system, but rather, always reflect a dynamic compromise among multiple systems. In this sense then, the best any system can ever do is modulate (i.e., constrain) effector-control systems (i.e., action).

4. Regularities, self, and other in event control

The discovery that perception and action-planning share common resources constitutes a regularity in cognitive systems that is not accounted for in traditional models. As a result, the existence of such regularities makes it difficult to sustain the folk-psychological notion of perception as 'seeing' and action as 'doing.' To 'see' is to simultaneously 'plan.' What does this imply for the concept 'self'? As a first step, it invites a re-examination of what it is that one plans (i.e., pre-specifies). The traditional notion asserts that 'actions' are pre-specified, while the notion of event control asserts that 'distal events' (i.e., outcomes in the world) are pre-specified. Though the differences may seem more semantic than scientific, the difference nonetheless leads to a rather revealing question: What is the spatial location of the events that are pre-specified? *Pre-specified*

action refers to events that reside within limb patterns, while *pre-specified distal events* refers to events that reside in the environment. This latter claim is, of course, a basic assumption of the Theory of Event Coding—action plans refer to the distal events the limb movements (i.e., actions) are to produce (Hommel et al., 2001).

4.1. *Inferring another's intentions*

If the first-person spatial referent of a pre-specification is a distal event, what about the third person perspective? Are the inferred intentions of others inferred pre-specifications of limb patterns or inferred pre-specifications of distal events? In what follows, I describe an experiment (Jordan & Hershberger, 1989) that seems to shed light on this issue. The experiment was originally conducted to investigate the phenomenon of perceived intentionality in others. However, the results prove to be consistent with the idea that the inferred intentions (i.e., pre-specifications) of another refer to the distal event the other is working to produce.

Jordan and Hershberger (1989) asked participants to observe an individual who was interacting with items on a computer monitor. Specifically, the individual (i.e., the controller) was attempting to keep a letter 'X' situated in the middle of the screen. Unbeknownst to the participants, the position of the X was continuously disturbed by a computer program. A letter 'O' was also on the screen, somewhat below the X, and the O's location was determined solely by the position of the computer mouse. Thus, as the controller moved the mouse back and forth to offset computer generated disturbances to the position of X, the position of X actually changed very little, while the position of O varied directly with the controller's mouse movements. The position of the X (i.e., a distal event) was what the controller was pre-specifying, while the position of the O represented the actions (i.e., limb movements) the controller was using to keep X in its pre-specified location.

The purpose of the experiment was to determine the conditions under which participants would falsely experience the position of O as the controller's intention. Thus we manipulated both the controller's and the participants' form of participation. The controller participated in one of two ways. In the Continuous condition, he controlled the position of X non-stop for 3 min. In the Discontinuous condition, he removed his hand from the mouse during the second of the three minutes. During this second minute, the O remained stationary (because the mouse was not moving) while the X moved back and forth in a random pattern (because the computer disturbance was not being offset by mouse movements). This, of course, afforded participants an opportunity to see what happened on the computer monitor when the controller was not controlling.

Observers also participated in one of two ways. In the Passive condition, they simply observed the controller for 3 min. In the Active condition, they interacted with him, and they did so via a joystick whose movements influenced the position of either the X or the O. Observers could switch between the two letter options via a switch setting at any time during the 3-min session. By completely crossing these two variables (i.e., controller and observer participation) we were able to assess which of the two had the greater impact on the observer's perceived intentionality.

At the beginning of each session, participants were told their task was to determine what the controller was doing. In other words, which of the two letters best represented the controllers' behavior. After the session, the participants indicated their answer and then answered two more questions, one about the X and one about the O. Specifically, observers were asked to indicate

whether the letter in question represented the controller's voluntary, intentional behavior, his involuntary unintentional behavior, or neither. In every condition, more than 50% of participants selected O as (1) best representing the controller's behavior, and (2) representing his voluntary intentional behavior. This percentage varied significantly between conditions however, as participants gained access to more information about the controller's relationship to the letters. Both manipulations (i.e., Continuous/Discontinuous and Passive/Active) resulted in main effects, with a significantly larger percentage of participants selecting X in the Discontinuous and Active cells. There was no interaction between the two variables however, which indicates that each manipulation had its own unique effect on the observer's perceived intentionality. Specifically, the Continuous/Discontinuous manipulation revealed what happened to the letters when the controller was not engaged, while the Passive/Active manipulation revealed what happened when the participants themselves were engaged. The combination of these two sources of information in the Active/Disengaged condition produced the smallest percentage of participants selecting O.

These data shed light on the nature of inferred intentions (i.e., third person inferences about the intentions of another) because they reveal that what participants 'saw' the controller causing was a distal event (i.e., the position of a letter), not limb movements. Even when participants selected O as best representing the controller's behavior, they also identified it as representing voluntary, intentional behavior. In other words, what they experienced was the controller attempting to move the O back and forth across the screen. Thus, the inferred intention referred to a distal event, not a pattern of limb movement. The idea here is that the regularities referred to via the third person usage of the concept 'self' do not exist within the skin of the other, but rather, at a larger scale that entails both the other and the environmental effects the other is working to produce. To be sure, regularities do exist within another's limb movements. The concept 'self' however, tends to be reserved for the larger-scale regularities entailing others and their environmental effects.

4.2. *Anticipating another's intentions*

If it is truly the case that inferences regarding the intentions of others refer to distal events, it may also be the case that anticipations regarding what another *will* do might also refer to distal events. If this is so, then perception should be influenced by whether one does a task alone or with another. This is because the event-control approach also asserts that perception and action planning share resources. Thus, any factor that has to be incorporated into one's distal-effect plans, including the anticipated events of another, should give rise to changes in perception. To test this idea, Jordan and Knoblich (in press) completed a variant of the Jordan et al. (2002) paradigm regarding perceived vanishing points. Specifically, participants moved a dot stimulus back and forth across a computer monitor as quickly as possible and they controlled the dot by pressing buttons (i.e., a right one and a left one) that increased or decreased the dot's velocity, depending on its direction of travel. If the dot was moving to the right, a right press increased its velocity to the right, while a left press decreased its velocity to the right. In order to move the dot back and forth across the screen, participants had to decelerate it (i.e., brake it) before it reached the edge of the screen. At an unpredictable moment during the braking phase, the dot vanished, and participants were asked to use the computer mouse to move a cursor to the perceived vanishing point. (To control for effects of stimulus velocity on perceived vanishing point, we

programmed the dot to vanish when the velocity reached a certain value.) Participants completed the task either alone (i.e., the Individual condition) or as a member of a pair (i.e., the Group condition). To increase the need for anticipation, we manipulated the impact of the button presses. Specifically, High-impact presses produced relatively large changes in dot velocity, while Low-impact presses produced relatively little change. Fig. 3 illustrates the results.

The first thing to note about Fig. 3 is that in all conditions the perceived vanishing point is beyond the actual vanishing point (i.e., it is greater than zero). As was the case in the Jordan et al. (2002) study, continuous tracking requires the incorporation of anticipated target locations in one's planning. Thus, since perception and action planning share resources, the anticipatory content of the plan biases the perceived vanishing point in the direction of the anticipation. The next thing to notice about Fig. 3 is the Impact effect. Specifically, High-impact presses gave rise to less perceptual displacement than Low-impact presses. This is because in the High-impact condition, participants could anticipate more deceleration per button press than in the Low-impact condition. These High-impact action plans (i.e., planned distal events) therefore, entailed less anticipated dot movement than Low-impact plans. Thus, when the dot unexpectedly vanished, High-impact plans gave rise to less perceptual displacement.

The Impact effect is, of course, completely consistent with the findings of the Jordan et al. (2002) study. What is unique about the Jordan and Knoblich study is the finding that the magnitude of the perceived displacement varies as a function of the participant's social context. Specifically, perceived displacement is highest when one does the task with another and the dot vanishes while the other is attempting to brake, and it is lowest when one does the task alone. According to the distal-event approach the reason for these differences has to do with need to incorporate potential interference into one's action plans. While braking in the Individual condition, one can be rather certain one will not interfere with oneself. While braking in the Group-act condition however, one has control over the dot but can never be certain whether or not the other will produce a conflicting button press. The need to incorporate this potential effect of the other into one's plans causes an increase in the magnitude of the perceptual displacement (due to

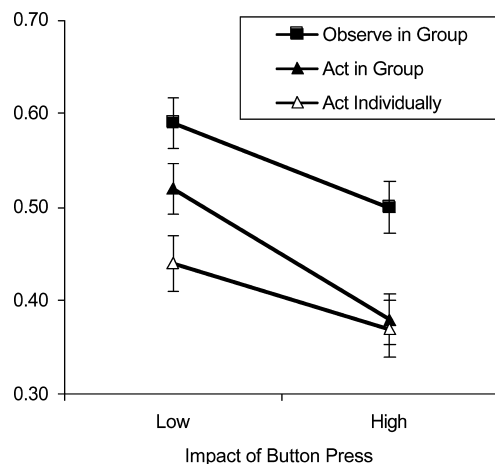

Fig. 3. Perceptual displacement scores in the Individual, Group-act, and Group-observe conditions as a function of Impact.

perception and action planning sharing resources). Finally, in the Group-observe condition, one has to give up control of the dot (i.e., has to allow the other to brake it), yet must stay engaged in the task in order to know when to take control of it. Under these conditions, one's plans are even more uncertain. As a result they entail more anticipation and give rise to greater perceptual displacements.

Collectively, these findings support the notion of event control and its assertions that (1) pre-specification (i.e., planning) is in terms of distal events, and (2) perception and event-planning share resources. The data also support the assertion that anticipation regarding another actor is incorporated into one's own action plans in terms of the distal events one anticipates the other will produce. Thus, both inferences and anticipations about another refer, not to actions, but to the distal events the other is producing or may produce, respectively.

4.3. Experiencing another

A final implication of event control is that experiencing another might also be in terms of the distal events the other works to produce, for if perception and planning share common resources, then seeing is, to some extent, planning. This implies that the experience of another is inherently laden with planning (i.e., intentional) content. Though this implication may seem far-fetched, there are cognitive scientists who have tried to say much the same thing. Kinsbourne (2002) for example, in his account of infant imitation, states that, "...infant imitation is neither deliberate nor reflex. It is the infant perceiving (enactively) the other's facial gesture. The action of perception activates the infants own corresponding movement patterns" (p. 316). And while defining 'enactive' perception, Kinsbourne states, "Percepts are encoded enactively, that is, in terms of the response possibilities that they afford" (p. 311). Though Kinsbourne appears to accept, to some degree, the notion of perceiving as 'seeing,' he nonetheless attempts to define 'seeing' in a way that imbues it with planning (i.e., action activating) content. Rizzolatti et al. (2002) make a somewhat similar appeal when they conceptualize mirror neurons as 'resonators,' whose purpose is to, "...generate a representation of what another individual is doing" (p. 258). The advantage of the term 'resonator' in this case is that it addresses the fact that the activity of mirror neurons entails both 'seeing' and 'planning' content. As they 'resonate' to the activities of conspecifics, the resonance simultaneously serves as detection (i.e., perception) and planning (i.e., pre-specification). Collectively then, the above-mentioned findings seem to indicate that inferring the intentions of another, anticipating the intentions of another, and experiencing another all refer to distal events. In short, we experience others in the same format we experience ourselves—in terms of the distal events either we, or they, work to produce.

5. Concluding remarks

In this paper I have proposed an approach (i.e., the event-control approach) that models perception and pre-specification (i.e., planning) as (1) sharing common resources, and (2) being synergistically coupled with effector control systems (i.e., action). This differs from the traditional approach, which models (1) perception and action as functionally orthogonal, and (2) planning and action as sharing direct causal links. These differences prove important to the

concept 'self,' for while the latter model leads to the 'self' being epiphenomenal (because pre-specification does not 'cause' action), the former asserts that pre-specifications refer to distal events (i.e., not actions) and can therefore only constrain (i.e., not 'cause') action. As a result of these differences, it seems the notion of event-control might make it possible to map the concept 'self' onto the notion of a distal-event system. To be sure, the purpose of doing so is not to make a case for the causality of the self. Rather, the purpose is to make the case that there do exist regularities in the natural order to which the concept 'self' can be appropriately applied. Using the concept 'self' to refer to such regularities is a much different enterprise than modeling 'the self' mechanistically as a potential cause of one's actions. In the former, one takes the concept for what it is—a concept. In the latter, one reifies the concept and attempts to determine whether or not the 'mechanism' is efficacious. Given that the latter approach leads one to the conclusion that regularities that actually do exist in the natural order (i.e., the phenomenal sense of agency and inferred intentions of others) are ultimately epiphenomenal, the former approach seems the more coherent bet.

But is this sufficient? Don't most organisms produce distal events? If so, does the concept 'self' map onto all organisms? If we answer 'yes' the term 'self' quickly loses its descriptive utility. If we answer 'no' however, we then have to divide the animal kingdom into those that qualify and those that do not. In contrast to these extreme options, the notion of event control implies that the issue of whether or not the concept 'self' can be coherently mapped onto an organism should be treated more as a gradient than a dichotomy, and the dimension underlying the gradient should be the type of distal events an organism can pre-specify, monitor, and produce (i.e., control). Fig. 4 illustrates this idea.

The dimension that varies in Fig. 4 is the spatio-temporal distality of the events an organism can control. This is meant to be an elaboration of Fig. 1, which modeled perception and action as synergistically coupled control loops that afford one the ability to pre-specify, monitor and produce (i.e., control) distal events via the constraint of effector control systems. The additional loop in Fig. 4 (i.e., the virtual-effect loop) is meant to model the human ability to generate and evaluate virtual events (i.e., thoughts) that can ultimately constrain the events the lower level loops work to control. As an example, one can generate and evaluate a plan to catch a flight to the Bahamas. Up until the moment one is actually seated in the plane, the event 'catch a flight to the Bahamas' is a virtual event. Regardless of its 'virtual' status however, the plan is fully capable of constraining one toward producing events in one's immediate environment such as buying tickets, packing clothes, and driving to the airport. And once one is engaged in producing such events, these plans (e.g., 'buy a ticket') are fully capable of constraining one's immediate relationship to the environment. Fig. 4 then, replaces the traditional single-loop model of psychological functionality (i.e., Fig. 1) with a hierarchy of nested control systems, each of which is responsible for pre-specifying, monitoring, and producing outcomes at a different level of scale.

Given that these systems are all coupled and function simultaneously, one can be said to be controlling (i.e., pre-specifying, monitoring, and producing) multiple events at the same time. The temptation of course is to identify one particular loop with the 'self.' It may be the case however that the phenomenal regularities referred via the concept 'self' can find themselves attached to different levels of event control at different moments in time. A beginning pianist for example, probably has a strong sense of self attached to his/her attempt to control the

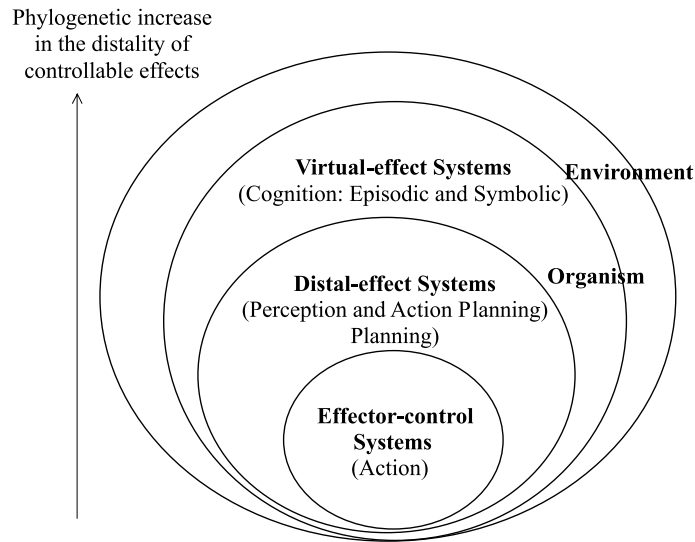

Fig. 4. Event-control hierarchy. The traditional psychological functions of action, perception and cognition are modeled as synergistically coupled levels of event control, as opposed to separate functions of a single control loop (i.e., Fig. 1). This adds a third loop (i.e., the Virtual-effect systems) to the two loops depicted in Fig. 1 (bottom). This model takes into account recently discovered common resources between perception and action-planning, and also illustrates the 'constraining' relationship between planning and action, as opposed to the 'causal' relationship assumed in traditional models. According to this model, a first-person sense of 'self' is fluid, and can find itself attached to different levels of event control at different moments.

relationship between finger positions and keys. Pre-specifying, monitoring, and producing these relationships constitutes the task at hand. For an expert pianist however, who has long since automated the control of finger–key relationships, the sense of self is perhaps most intimately tied to the control of the flow of emotions provoked by the piece. This notion is consistent with Vallacher, Wegner, and Somoza's (1989) theory of action identification. Basically, this theory asserts there exists a hierarchy of 'identities' an actor can ascribe to an action (e.g., identifying the pressing of keys on a piano as "playing a scale" versus "playing a sonata"), and that during any given action, only one of these possible identities is prepotent for the actor. If this is the case, and one's sense of self is contextualized by the chosen action identity (i.e., the pre-specified level of event control), then the sense of self is dynamic and fluid, and pinning it down to one particular level of event control (i.e., identity) seems difficult, if not impossible. Despite its fluidity however, there do seem to be levels of event control that are more appropriately referred to via the concept 'self.' Specifically, I will close the present paper by proposing that the concept 'self' seems most appropriately applied to events that one controls with another. For during such control, one must be able to specify, monitor, and produce one's own events in relation to the anticipated events of the other. These pre-specified, anticipated events are of course, virtual. And in the act of distinguishing them we generate an intentional relation between agents. In this relation, the sense of self is simultaneously most independent and dependent. It is most independent in the sense that it finds itself most clearly defined, yet most dependent because the clarity emerges in relation to another.

Acknowledgments

I thank Bernhard Hommel and William Banks for their insightful comments on an earlier version of the manuscript.

References

- Bargh, J., & Chartrand, T. (1999). The unbearable automaticity of being. *American Psychologist*, *54*(7), 462–479.
- Bargh, J., Chen, M., & Burrows, L. (1996). Automaticity of social behavior: Direct effects of trait construct and stereotype activation on action. *Journal of Personality and Social Psychology*, *71*, 230–244.
- Barresi, J., & Moore, C. (1996). Intentional relations and social understanding. *The Behavioral and Brain Sciences*, *19*(1), 107–122.
- Chen, M., & Barch, J. (1997). Nonconscious behavioral confirmation processes: The self-fulfilling consequences of automatic stereotype activation. *Journal of Experimental Social Psychology*, *33*, 541–560.
- Clark, A. (2001). *Mindware*. New York, Oxford: Oxford University Press.
- Decety, J. & Chaminade, T. (2003). When the self represents the other: A new cognitive neuroscience view on psychological identification. *Consciousness and Cognition*, *12*.
- Di Pellegrino, G., Fadiga, L., Fogassi, V., Gallese, V., & Rizzolatti, G. (1992). Understanding motor events: A neurophysiological study. *Experimental Brain Research*, *91*, 176–180.
- Hommel, B., Müsseler, J., Aschersleben, G., & Prinz, W. (2001). The theory of event coding (TEC). A framework for perception and action planning. *Behavioral and Brain Sciences*, *24*, 849–937.
- Hubbard, T. (1995). Environmental invariants in the representation of motion: Implied dynamics and representational momentum, gravity, friction, and centripetal force. *Psychonomic Bulletin & Review*, *2*(3), 322–338.
- Jordan, J. S. (in press). The embodiment of intentionality. In W. Tschacher (Ed.), *Dynamical systems approaches to embodied cognition*. Berlin: Springer.
- Jordan, J. S., & Hershberger, W. A. (1989). The behavioral illusion: The misperception of volitional action. In W. A. Hershberger (Ed.), *Volitional action: Conation and control* (pp. 371–386). North Holland: Elsevier.
- Jordan, J. S. & Knoblich, G. (in press). Spatial perception and control. *Psychonomic Bulletin & Review*.
- Jordan, J. S., Stork, S., Knuf, L., Kerzel, D., & Müsseler, J. (2002). Action planning affects spatial localization. In W. Prinz & B. Hommel (Eds.), *Attention and performance XIX: Common mechanisms in perception and action* (pp. 158–176). Oxford: Oxford University Press.
- Kerzel, D., Jordan, J. S., & Müsseler, J. (2001). The role of perceptual anticipation in the localization of the final position of a moving target. *Journal of Experimental Psychology: Human Perception and Performance*, *27*(4), 829–840.
- Kinsbourne, M. (2002). The role of imitation in body ownership and mental growth. In A. Meltzoff & W. Prinz (Eds.), *The imitative mind* (pp. 311–330). New York, Oxford: Oxford University Press.
- Metzinger, T., & Gallese, V. (2003). The emergence of a shared action ontology: Building blocks for a theory. *Consciousness and Cognition*, *12*.
- Müsseler, J., & Wühr, P. (2001). Response-evoked interference in visual processing. In W. Prinz & B. Hommel (Eds.), *Common mechanisms in perception and action: Attention and performance XIX* (pp. 520–537). New York, Oxford: Oxford University Press.
- Premack, D., & Woodruff, G. (1978). Does the chimpanzee have a theory of mind? *The Behavioral and Brain Sciences*, *1*(4), 515–526.
- Prinz, W. (1992). Why don't we perceive our brain states? *European Journal of Cognitive Psychology*, *4*(1), 1–20.
- Prinz, W. (1997). Perception and action planning. *European Journal of Cognitive Psychology*, *9*, 129–154.
- Rizzolatti, G., Fadiga, L., Fogassi, L., & Gallese, V. (2002). From mirror neurons to imitation: Facts and speculations. In A. Meltzoff & W. Prinz (Eds.), *The imitative mind*. New York, Oxford: Oxford University Press.
- Rossetti, Y., & Pisella, L. (2001). Several different 'vision for action' systems: A guide to dissociating and integrating dorsal and ventral functions. In W. Prinz & B. Hommel (Eds.), *Common mechanisms in perception and action: Attention and performance XIX* (pp. 62–119). New York, Oxford: Oxford University Press.

- Shiffrin, R. M., & Schneider, W. (1977). Controlled and automatic human information processing: II. Perceptual learning, automatic attending, and a general theory. *Psychological Review*, 84, 127–190.
- Taira, M., Mine, S., Georgopoulos, A. P., Murata, A., & Sakata, H. (1990). Parietal cortex neurons of the monkey related to the visual guidance of hand movement. *Experimental Brain Research*, 83, 29–36.
- Vallacher, R. R., Wegner, D. M., & Somoza, M. P. (1989). That's easy for you to say! Action identification and speech fluency. *Journal of Personality and Social Psychology*, 56(2), 199–208.
- Wegner, D. M. (2002). *The illusion of conscious will*. London: MIT Press.
- Wegner, D. M. (2003). Voluntary in voluntariness: Thought suppression and the regulation of the experience of will. *Consciousness and Cognition*, 12.
- Wegner, D. M., & Wheatley, T. (1999). Apparent mental causation: Sources of the experience of will. *American Psychologist*, 54, 480–491.