

MODULAR ELECTRONICS LEARNING (MODEL) PROJECT



MULTI-TRANSISTOR AMPLIFIERS

© 2020-2025 BY TONY R. KUPHALDT – UNDER THE TERMS AND CONDITIONS OF THE
CREATIVE COMMONS ATTRIBUTION 4.0 INTERNATIONAL PUBLIC LICENSE

LAST UPDATE = 18 FEBRUARY 2025

This is a copyrighted work, but licensed under the Creative Commons Attribution 4.0 International Public License. A copy of this license is found in the last Appendix of this document. Alternatively, you may visit <http://creativecommons.org/licenses/by/4.0/> or send a letter to Creative Commons: 171 Second Street, Suite 300, San Francisco, California, 94105, USA. The terms and conditions of this license allow for free copying, distribution, and/or modification of all licensed works by the general public.

Contents

1	Introduction	3
1.1	Recommendations for students	3
1.2	Challenging concepts related to multi-stage amplifier circuits	5
1.3	Recommendations for instructors	6
2	Case Tutorial	7
2.1	Example: detailed analysis of current mirror	8
2.2	Example: one amplifier stage loading another	11
2.3	Example: multi-stage transistor amplifier with negative feedback	15
2.4	Example: simple push-pull power amplifier stage	17
3	Tutorial	21
3.1	Amplifier gain comparisons	22
3.2	Paired transistors	23
3.3	Cascaded stages	26
3.4	Push-pull amplifiers	30
3.5	Differential pairs	38
3.6	Current mirrors	41
3.7	Active loading	46
3.8	Typical audio power amplifier design	53
4	Animations	57
4.1	Animation of an NPN BJT turning on	58
4.2	Animation of class-B crossover distortion	73
5	Questions	95
5.1	Conceptual reasoning	99
5.1.1	Reading outline and reflections	100
5.1.2	Foundational concepts	101
5.1.3	Discrete analysis of a bipolar AND gate	103
5.1.4	Discrete analysis of a bipolar OR gate	105
5.1.5	Model 324 differential amplifier qualitative analysis	107
5.1.6	Identifying component functions	108
5.1.7	Audio amplifier evaluation	110

5.1.8	Direct versus capacitive stage coupling	112
5.1.9	Transformer stage coupling	113
5.1.10	Compensating capacitor	114
5.1.11	Paralleled transistors	115
5.1.12	Volume control location	117
5.1.13	Push-pull amplifier with phase splitter	118
5.1.14	Transformer-coupled push-pull amplifier	119
5.1.15	Cascode amplifier	120
5.1.16	Direct-coupled amplifier with negative feedback	121
5.2	Quantitative reasoning	123
5.2.1	Miscellaneous physical constants	124
5.2.2	Introduction to spreadsheets	125
5.2.3	Audio amplifier quiescent values	128
5.2.4	Approximating voltage gain	130
5.2.5	Ideal load impedance	131
5.2.6	Current mirror calculations	132
5.3	Diagnostic reasoning	133
5.3.1	General amplifier troubleshooting tips	134
5.3.2	Diagnostic strategy for a two-stage audio amplifier	135
5.3.3	Divide and conquer	136
5.3.4	Effects of faults on quiescent voltages	137
5.3.5	Amplifier signal clipping	138
5.3.6	Symmetrical amplifier signal clipping	139
5.3.7	Push-pull amplifier distortion	140
5.3.8	Amplifier simulation program	142
A	Problem-Solving Strategies	145
B	Instructional philosophy	147
C	Tools used	153
D	Creative Commons License	157
E	References	165
F	Version history	167
	Index	169

Chapter 1

Introduction

1.1 Recommendations for students

Transistors are incredibly useful electronic components, but their limitations are such that for most applications it is impossible for any *single* transistor to provide suitable amplification. It is for this fundamental reason that most amplifiers rely on *multiple* transistors to satisfy all necessary performance requirements.

Important concepts related to multi-transistor amplifiers include **BJT behavior, gain, phase shift, beta ratio, PN junction behavior, saturation, filter networks, signal coupling, transformers, capacitive reactance, negative feedback, voltage divider networks, sources versus loads, sinking versus sourcing, crossover distortion, biasing, differential pair networks, Kirchhoff's Voltage Law, Kirchhoff's Current Law, comparators and operational amplifiers, operational classes** for amplifier circuits, and **current mirrors**.

Here are some good questions to ask of yourself while studying this subject:

- How might an experiment be designed and conducted to measure the gain of an amplifier circuit? What hypotheses (i.e. predictions) might you pose for that experiment, and what result(s) would either support or disprove those hypotheses?
- What are some of the advantages and disadvantages of the different “common” terminal amplifier types?
- How is voltage gain determined for a given transistor amplifier?
- How is current gain determined for a given transistor amplifier?
- How do Darlington and Sziklai pair configurations work to boost current gain?
- What condition(s) must be met to saturate a BJT in its “on” state?
- What are some different methods to couple the stages in a multi-stage amplifier circuit?
- What distinct advantage does the *cascode* amplifier enjoy over others?

- What distinguishes the different “classes” of amplifier operation from one another?
- Why are even-numbered harmonics typically present in the distortion caused by single-transistor amplifiers?
- Why are odd-numbered harmonics typically present in the distortion caused by push-pull transistor amplifiers?
- What is crossover distortion in push-pull amplifiers?
- How is crossover distortion typically mitigated in push-pull amplifiers?
- What is distinctive about the differential pair amplifier, compared to some of the others?
- By what principle(s) is current regulated through the active transistor of a current mirror circuit?
- Why is active loading employed in some transistor amplifiers?
- Where exactly is “current mirroring” employed in the model 339 IC comparator?
- Where exactly is “current mirroring” employed in the model 741 IC operational amplifier?
- Where exactly is “active loading” employed in the model 339 IC comparator, and what purpose does it serve?
- Where exactly is “active loading” employed in the model 741 IC operational amplifier, and what purpose does it serve?

1.2 Challenging concepts related to multi-stage amplifier circuits

The following list cites concepts related to this module's topic that are easily misunderstood, along with suggestions for properly understanding them:

- **Signal inversion** – some transistor circuits have an “inverting” characteristic in which a rising input signal results in a falling output signal. This is not necessarily obvious upon first inspection, but a good way to make the concept clearer is to run “thought experiments” on the circuit with multiple values of V_{in} , computing the value of V_{out} for each scenario, and seeing for yourself the effect one signal has on the other.
- **Common terminals in amplifier configurations** – BJT amplifier circuits are often categorized as being “common-emitter”, “common-collector”, or “common-base”, and it is usually unclear why this is so. One approach is to simplify these circuits to show them as *grounded-emitter*, *grounded-collector*, and *grounded-base*, respectively.
- **Gain calculations** – gain for any amplifier is most properly calculated as the ratio of output *change* to input *change*, not necessarily the ratio of output to input. For example, voltage gain is calculated as $A_V = \frac{\Delta V_{out}}{\Delta V_{in}}$, the “Delta” (Δ) symbols representing “change in” the designated variable(s). $\frac{\Delta V_{out}}{\Delta V_{in}}$ is equivalent to $\frac{V_{out}}{V_{in}}$ if and only if the amplifier in question outputs zero when the input is zero (i.e. when the transfer function is *purely linear* rather than merely being *affine*), which for simple one-transistor amplifiers is almost never true.
- **Energy efficiency** – Energy efficiency is defined as the ratio of energy directed out of a system toward useful work versus total energy put in to that system. In the context of an electronic amplifier, energy efficiency is the ratio of energy directed to the load versus total energy required to power the amplifier. The difference between load power and total power in is usually manifest as heat (thermal losses).

1.3 Recommendations for instructors

This section lists realistic student learning outcomes supported by the content of the module as well as suggested means of assessing (measuring) student learning. The outcomes state what learners should be able to do, and the assessments are specific challenges to prove students have learned.

- **Outcome** – Demonstrate effective technical reading and writing

Assessment – Students present their outlines of this module’s instructional chapters (e.g. Case Tutorial, Tutorial, Historical References, etc.) ideally as an entry to a larger Journal document chronicling their learning. These outlines should exhibit good-faith effort at summarizing major concepts explained in the text.

- **Outcome** – Apply the concepts of Ohm’s Law, Kirchhoff’s Voltage and Current Laws, and principles of bipolar junction transistors to amplifier circuit analysis

Assessment – Compute quiescent (DC) signal values for a given amplifier circuit; e.g. pose problems in the form of the “Audio amplifier quiescent values” Quantitative Reasoning question.

Assessment – Compute voltages and currents within a given current mirror circuit; e.g. pose problems in the form of the “Current mirror calculations” Quantitative Reasoning question.

- **Outcome** – Identify the functions of components from a schematic diagram

Assessment – Identify the purpose of each component within a multi-stage amplifier circuit’s schematic diagram; e.g. pose problems in the form of the “Identifying component functions” and “Audio amplifier evaluation” Conceptual Reasoning questions.

- **Outcome** – Compute amplifier voltage gain values

Assessment – Approximate voltage gain values for an amplifier circuit based on given component values; e.g. pose problems in the form of the “Approximating voltage gain” Quantitative Reasoning question.

Chapter 2

Case Tutorial

The idea behind a *Case Tutorial* is to explore new concepts by way of example. In this chapter you will read less presentation of theory compared to other Tutorial chapters, but by close observation and comparison of the given examples be able to discern patterns and principles much the same way as a scientific experimenter. Hopefully you will find these cases illuminating, and a good supplement to text-based tutorials.

These examples also serve well as challenges following your reading of the other Tutorial(s) in this module – can you explain *why* the circuits behave as they do?

2.1 Example: detailed analysis of current mirror

Current mirror networks are intended to duplicate one current by another, but their real-life behavior is never perfectly so. Here we will analyze a simple current mirror circuit in more detail than is customary, accounting for a realistic transistor beta (β) value:

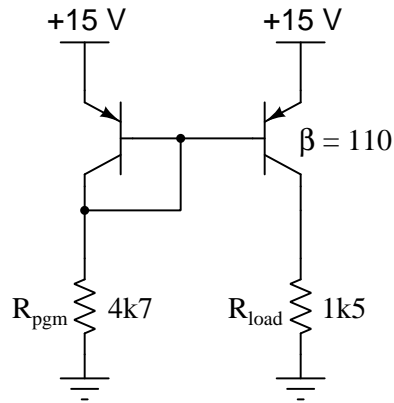

First we will determine the voltage dropped across R_{pgm} based on the assumption of a 0.7 Volt drop across both PN junctions. This leaves 14.3 Volts across R_{pgm} which in turn results in a programming current of 3.043 milliAmperes:

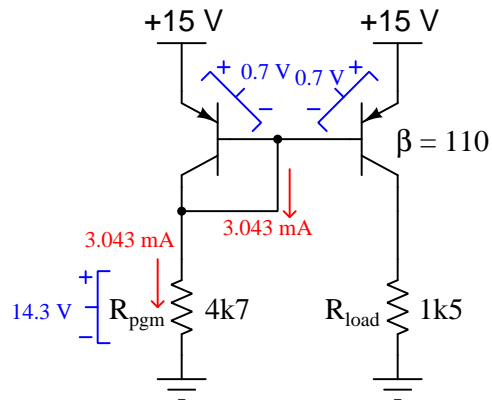

The entirety of this programming current goes through the “shorting jumper” that’s used to turn the left-hand transistor into a simple diode (single effective PN junction), but at the wire junction between the two transistors this current divides into smaller portions as shown here (with the unknown transistor base current simply labeled x):

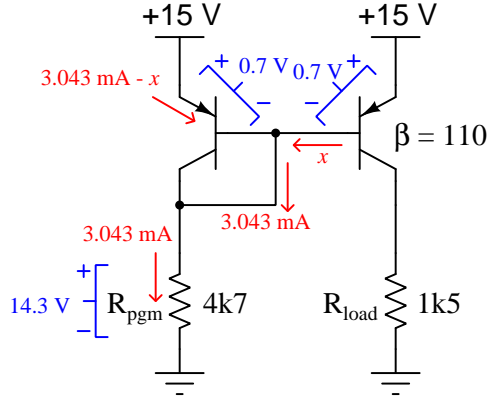

Voltage is dropped across any PN junction in accordance with the Shockley diode equation, and since the base-emitter terminal pair of both transistors are paralleled with each other it means both base-emitter PN junctions must see this same exact voltage (which we earlier approximated as 0.7 Volts):

$$I = I_S \left(e^{\frac{qV}{nKT}} - 1 \right)$$

If both base-emitter PN junctions are chemically identical (same n and same I_S) and are at the same temperature (same T), then having equal voltages (V) must result in equal currents (I) through those two PN junctions. This means the active transistor (on the right-hand side) must also have an emitter current equal to $3.043 \text{ mA} - x$ just like the transistor-turned-diode on the left:

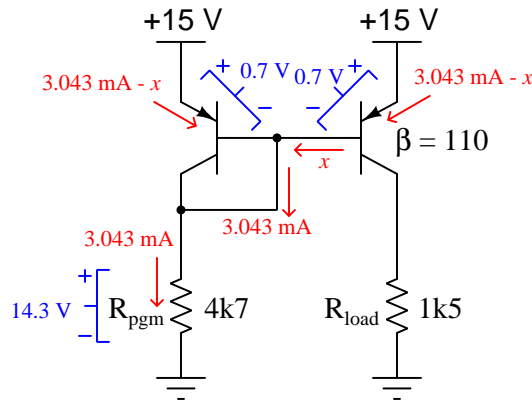

Beta (β) is defined as the ratio of collector to base current ($\beta = \frac{I_C}{I_B}$), but we may also use Beta to relate emitter to base currents by showing $\beta + 1 = \frac{I_E}{I_B}$. Knowing this, we may relate Beta to the emitter and base currents expressed algebraically:

$$I_B = x \quad I_E = 3.043 \text{ mA} - x \quad \beta + 1 = \frac{I_E}{I_B}$$

$$\beta + 1 = \frac{3.043 \text{ mA} - x}{x}$$

$$111 = \frac{3.043 \text{ mA} - x}{x}$$

$$111x = 3.043 \text{ mA} - x$$

$$111x + x = 3.043 \text{ mA}$$

$$112x = 3.043 \text{ mA}$$

$$x = \frac{3.043 \text{ mA}}{112}$$

$$x = I_B = 27.166 \mu\text{A}$$

Now that we know the value of the active transistor's base current, we may use Beta again to calculate its collector and emitter currents, and with that we now know all current values within this current mirror circuit, including the load current which must be 2.9882 milliAmperes:

$$I_C = \beta I_B = 2.9882 \text{ mA} \quad I_E = (\beta + 1)I_B = 3.0154 \text{ mA}$$

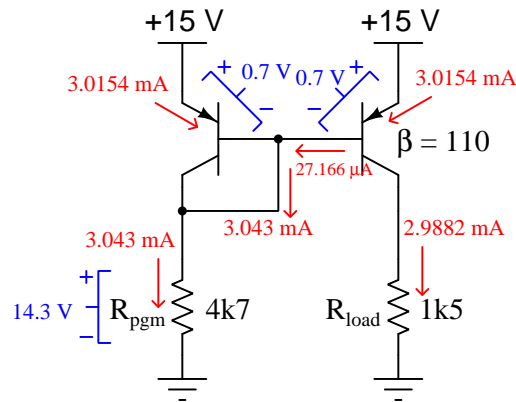

2.2 Example: one amplifier stage loading another

In this SPICE simulation we show a common-emitter amplifier appropriate for boosting the voltage of an audio signal from the output jack of a music player (e.g. an MP3 audio player), the amplitude of the raw audio signal typically in the range of hundreds of millivolts peak:

Circuit schematic diagram (with node numbers listed):

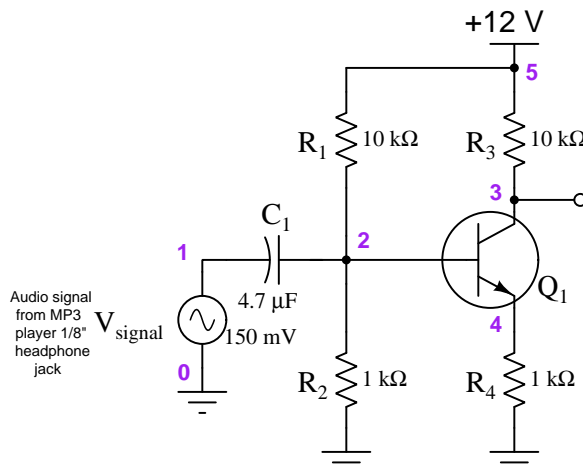

SPICE netlist:

```
* SPICE simulation of C-E audio amplifier
vcc 5 0 dc 12
vsignal 1 0 sin (0 150e-3 2e3 0 0)
r1 2 5 10e3
r2 2 0 1e3
r3 3 5 10e3
r4 4 0 1e3
c1 1 2 4.7e-6
q1 3 2 4 qmod
.model qmod npn bf=40
.tran 10u 102m 100m uic
.plot tran v(1) v(2) v(3)
.end
```

An important detail of this SPICE analysis appears in the `tran` (transient) analysis card of the netlist, where we specify the interval time duration (10 microseconds) followed by the “stop” time (102 milliseconds) followed by the “start” time (100 milliseconds). We intentionally delay the plotting of results until SPICE has performed the first 100 milliseconds of the analysis to give the

input capacitor and bias resistor network enough time for the capacitor's DC voltage to reach a stable value. Then, we plot for 2 milliseconds' worth of time (from 100 ms to 102 ms) in order to show four full cycles of the 2 kHz audio waveforms. In this case, we model the audio signal source as a sine wave with a peak voltage of 150 milliVolts, showing signals at nodes 1 (V_{signal}), 2 (biased V_{signal}), and 3 (amplifier output) with reference to ground:

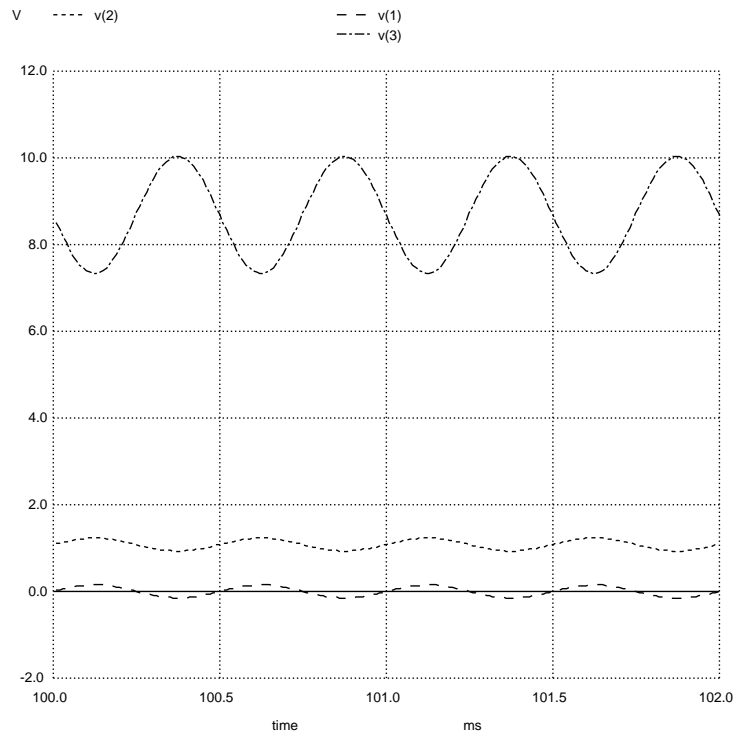

Estimating from the graph showing the amplifier's output voltage at node 3 ($v(3)$), we see approximately 1.35 Volts peak AC.

The output impedance of a common-emitter amplifier is simply the value of the collector resistor (R_3 in this circuit). Thus, from the perspective of the amplifier's output terminal, the Thévenin equivalent network consists of a 1.35 Volt (peak) AC source with a 10 k Ω series resistance:

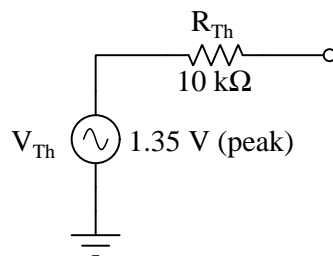

In this next SPICE simulation, we combine the common-emitter amplifier with a common-collector Darlington pair stage in order to lower the amplifier's over-all output impedance from 10 k Ω to something much lower:

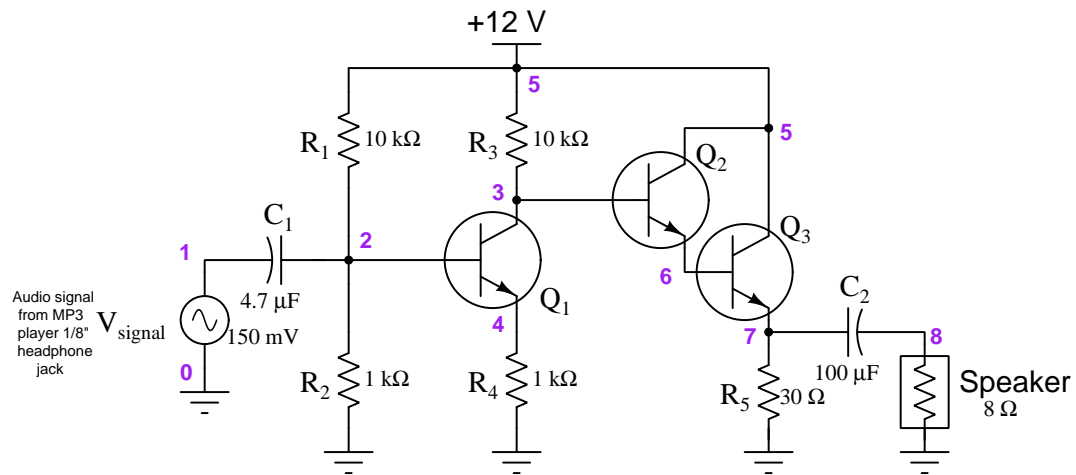

SPICE netlist:

```
* SPICE simulation of C-E audio amplifier with Darlington output stage
vcc 5 0 dc 12
vsignal 1 0 sin (0 150e-3 2e3 0 0)
r1 2 5 10e3
r2 2 0 1e3
r3 3 5 10e3
r4 4 0 1e3
c1 1 2 4.7e-6
q1 3 2 4 qmod
q2 5 3 6 qmod
q3 5 6 7 qmod
r5 7 0 30
c2 7 8 100e-6
rspeaker 8 0 8
.model qmod npn bf=40
.tran 10u 102m 100m uic
.plot tran v(1) v(3) v(8)
.end
```

The SPICE analysis shows an AC signal amplitude at node 3 that is significantly less than before when it was an unloaded single-stage amplifier circuit:

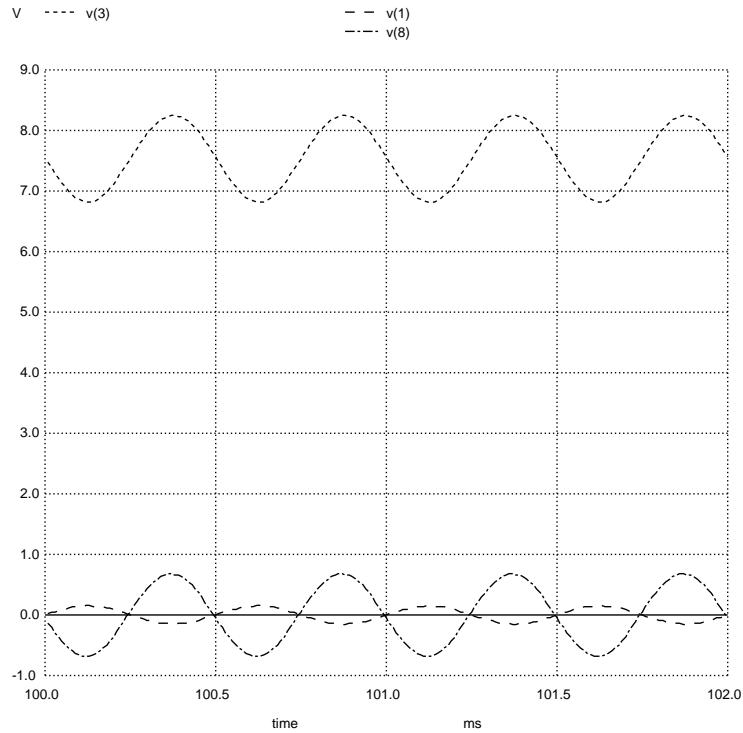

Instead of $v(3)$ being approximately 1.35 Volts peak, it is now approximately 0.70 Volts peak. This “sag” in the first stage’s output voltage may be explained in terms of Thévenin equivalent modeling, if we connect the Thévenin equivalent network previously shown for the first stage’s output terminal to a Thévenin equivalent network modeling the Darlington pair’s input impedance (equal to $(\beta + 1)^2$ times the combined parallel resistance of R_5 and speaker, assuming the capacitor’s reactance is low enough to be negligible):

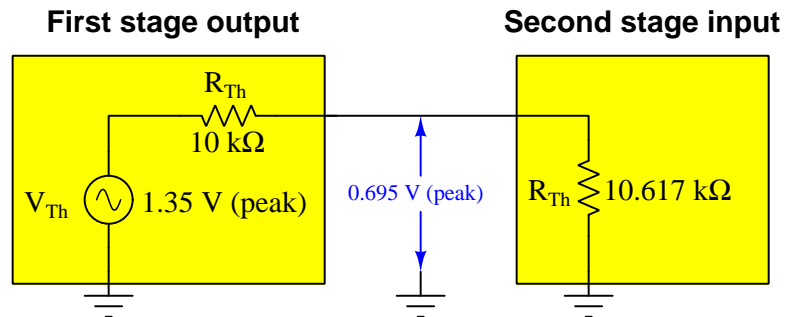

2.3 Example: multi-stage transistor amplifier with negative feedback

Single-stage transistor amplifiers are well-known for their somewhat unpredictable voltage gain behavior due to uncontrollable variations in transistor gain (beta for BJTs, and transconductance for FETs). However, if multiple stages are cascaded to produce a very high voltage gain, then negative feedback may be used to diminish that high voltage gain to a more reasonable (and much more stable!) value.

The following circuit shows how this may be done, using three grounded-emitter BJT amplifier stages to provide very high voltage gain and the inverting characteristic necessary for negative feedback:

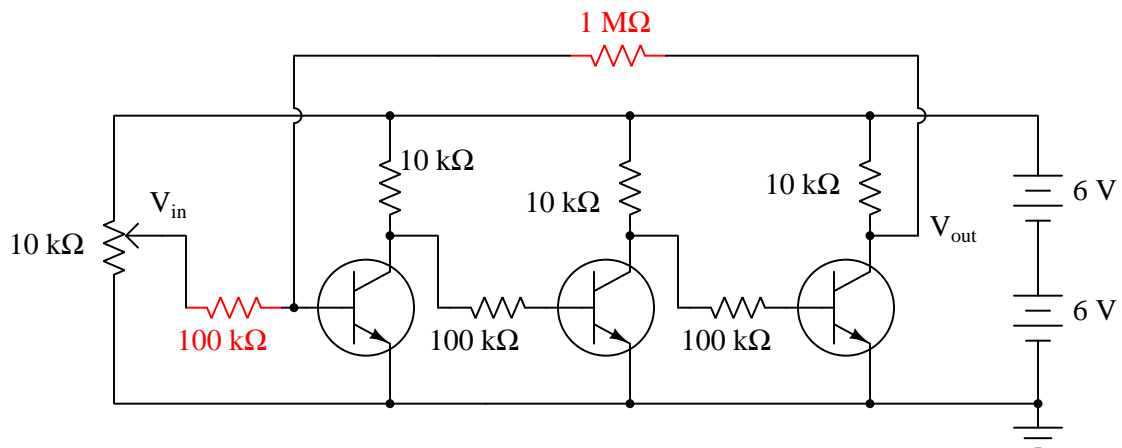

The $1\text{ M}\Omega$ feedback resistor in conjunction with the $100\text{ k}\Omega$ “input” resistor yield a 10:1 ratio, translating into a voltage gain value that is nearly exactly 10.

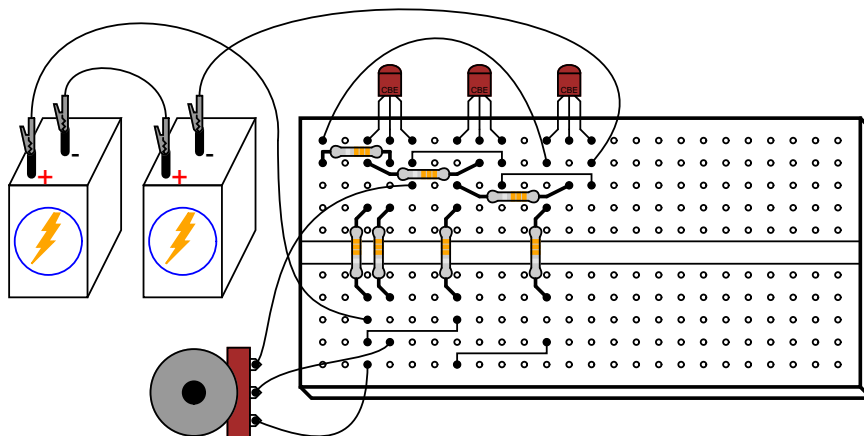

Each stage of this amplifier circuit is *inverting*, in that a rising input signal causes the output signal to fall. Over-all, the entire amplifier is also inverting because there is an odd number of these inverting stages cascaded – we could have just as readily coupled five common-emitter stages together, or seven, or nine, and still maintained the inverting characteristic we need. This characteristic is important because we want the feedback to be *negative* in sign: the output signal's direction must fight against the causal input signal's direction in order to bring stability to the circuit.

Although the notion of building an amplifier circuit to have an extremely high gain and then intentionally reducing that gain by way of negative feedback may seem counter-productive, the result is that the over-all gain becomes much more stable and the amplification becomes much more linear than with no feedback at all. As the transistors heat and cool, or if one must be replaced with another having slightly different characteristics, the strategy of arbitrarily high voltage gain intentionally scaled down via negative feedback results in those individual transistor variations having very little effect on the whole circuit's idealized performance.

This non-intuitive concept lies at the heart of Harold Black's 1920's era innovation, developed at a time when telephone repeater amplifiers used vacuum tubes as amplifying elements. These early tube circuits were notoriously unstable, the tubes' operating characteristics changing significantly as they aged. Black's application of negative feedback to the problem of electronic amplifier stability was revolutionary, and still holds merit with today's solid-state amplifier circuitry.

Operational amplifiers are perhaps the best and most common electronic application of this concept. Being integrate-circuit (IC) modules designed to provide extremely high voltage gain on their own, "opamps" are designed to be used in conjunction with negative feedback resistor networks like this to provide highly accurate and stable gains. This discrete transistor amplifier demonstrates the fundamental concept, but without the use of any integrated circuitry.

2.4 Example: simple push-pull power amplifier stage

This example circuit shows just how simple it is to construct a functional push-pull power amplifier for audio-frequency application using commonly-available electronic components:

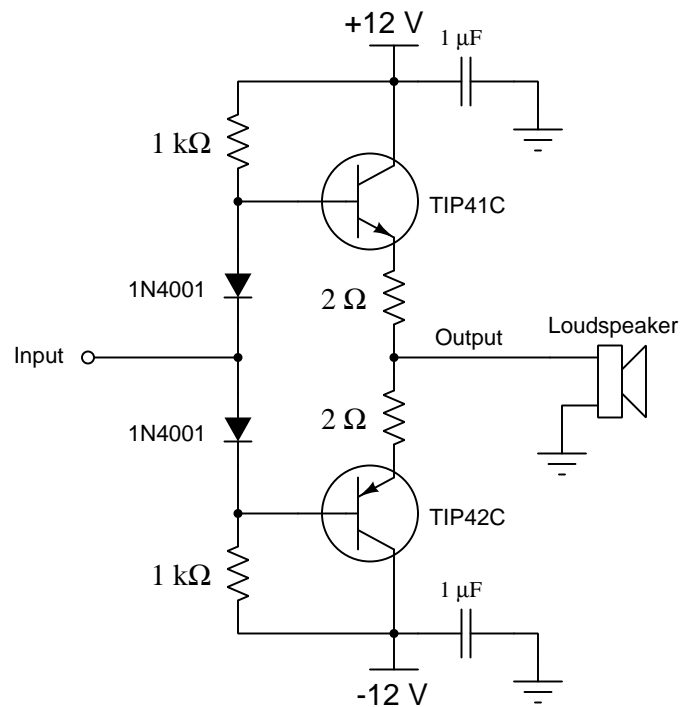

The two decoupling capacitors (1 microFarad each) are quite important, as they stabilize the split DC power rail voltages. Attaching heat sinks to the two power transistors is recommended for extended-duration tests. But short-duration tests at full power for a minute or two should be possible without any augmented cooling.

The breadboarded circuit takes up little space, even with care taken to separate the metal tabs of the two power transistors so they do not make electrical contact. This precaution is especially important in this push-pull amplifier circuit because the metal tabs of the TIP41 and TIP42 power transistors are each electrically common to those transistors' respective collector terminals. If the two metal tabs were to ever touch, it would create a direct short-circuit between the +12 and -12 Volt DC power rails:

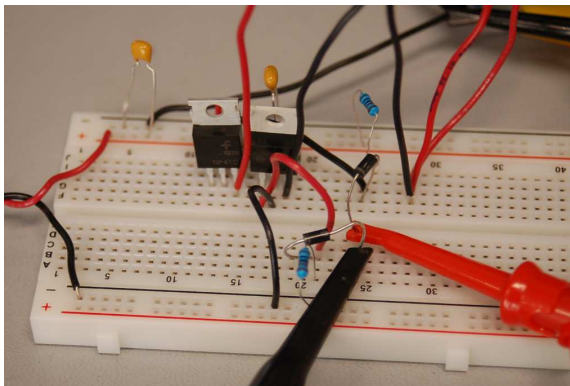

An oscilloscope comparison of input (blue) and output (yellow) signals at approximately 417 Hz shows a voltage gain of slightly less than unity (1), which is what we expect for a common-collector amplifier of any style:

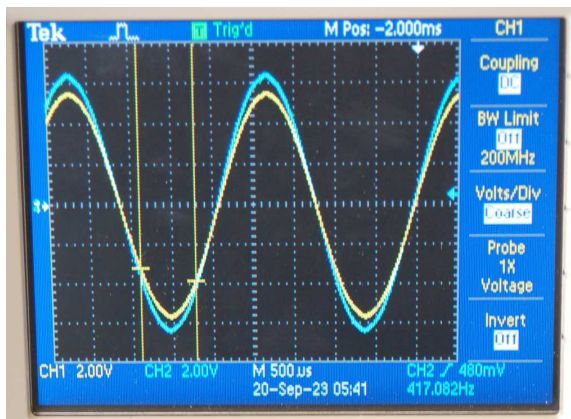

Current draw from the +12/-12 Volt split DC power supply during this test is approximately 155 milliAmperes while driving a small loudspeaker. With the signal generator turned off the quiescent current decreases to approximately 89 milliAmperes proving that the amplifier runs in class AB mode. This modality also explains why there is no perceptible crossover distortion in the output waveform.

A good practice to follow when testing this amplifier is to use DC coupling on both oscilloscope channels so that you will be able to see any DC bias present in either the input or the output signal. Problems with the biasing network, with either transistor's function, and other issues will be easier

to identify if the signals display on the oscilloscope with any DC offset. Leaving the oscilloscope's channels configured for AC coupling hides any bias from view, making such determinations more complicated during troubleshooting and testing.

An interesting test to conduct on this amplifier is to decrease the DC power supply voltage(s) to a point where the amplifier cannot match the signal level of the input. Here, we've decreased the +V and -V DC power supply rail voltages down far enough where the amplifier is only able to reach +5 Volts on the positive peaks and -5 Volts on the negative peaks, symmetrically "clipping" the sine wave:

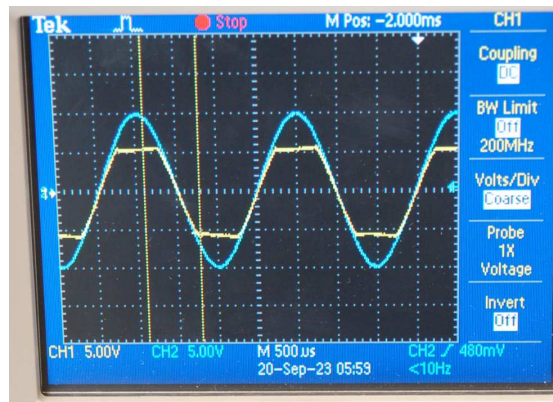

For a typical audio power amplifier this form of distortion would be undesirable as it noticeably distorts the waveform and generates a wide range of harmonic frequencies that interfere with how the signal is supposed to sound. In some applications, though, such as electric guitar amplifiers, such "clipping" is precisely what gives that instrument its characteristic timbre. Electric guitar players even have the ability to select how much "overdrive" they wish on their guitar's signal so produce varying degrees of (intentional) distortion!

Chapter 3

Tutorial

Single transistors are useful as amplifiers, but they are limited. Some single-transistor amplifier circuit designs yield high voltage gain, some high current gain, some are inverting, some are non-inverting, some exhibit high impedances, others low impedances. Each design has its own advantages and disadvantages, and with these unique characteristics comes the challenge of finding an appropriate amplifier design for any particular application. Many practical applications require combinations of traits not found in any one single-transistor circuit design, and for this reason most electronic amplifiers utilize multiple transistors to achieve what one could not.

This Tutorial will begin with a brief review of single-transistor amplifier circuits and then immediately proceed into amplifier configurations using multiple transistors.

3.1 Amplifier gain comparisons

First, we will review the three basic BJT amplifier configurations, each one defined by the particular transistor terminal “common”¹ to both input and output voltages:

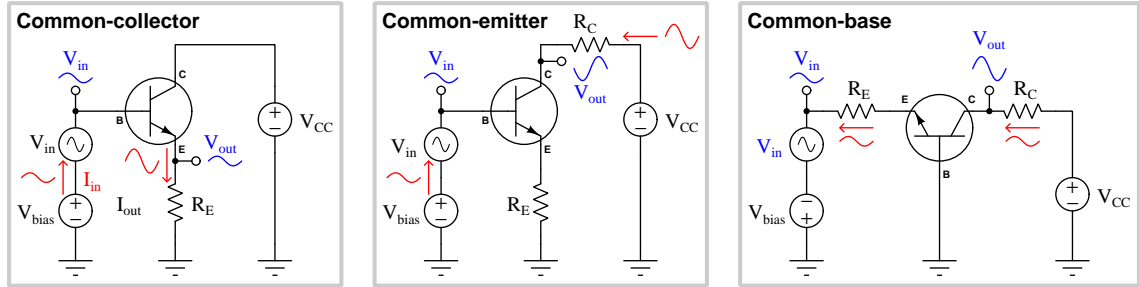

Amplifier configuration	AC voltage gain	AC current gain
Common-collector	≈ 1 maximum	$\beta + 1$ maximum
Common-emitter	$\approx -\frac{R_C}{R_E}$ maximum	β maximum
Common-base	$\approx \frac{R_C}{R_E}$ maximum	≈ 1 maximum

Note how the common-emitter configuration is the only amplifier circuit with a “negative” or “inverting” voltage gain. This means the output voltage signal will be phase-shifted by 180° from the input voltage signal. For the other two amplifier configurations, there is no phase shift between V_{out} and V_{in} and as such they have “positive” or “non-inverting” voltage gains.

Gain values are shown as “maximum” because the practical gain depends on the load resistance connected between the output terminal and ground. Values and formulae specified in the table are valid only for cases where the load is one of the circuit resistances (e.g. R_C for the common-emitter and common-base, R_E for the common-collector) and nothing else is connected to the output terminal. Any connected load resistance will tend to drive voltage gain and current gain to lower values. A noteworthy exception to this rule is voltage gain for the common-collector amplifier, which remains very nearly 1 with or without external load resistance.

¹This makes sense when you short all DC voltage sources (V_{bias} and V_{CC}) in each circuit as you would when applying Superposition, Thévenin’s, or Norton’s theorems. In the common-collector configuration, for example, the collector terminal becomes electrically common with ground once V_{CC} is shorted, and it is clear then how we may rightfully call it a “common collector” configuration. The common-emitter configuration is the most difficult one to see, since even with the DC sources shorted the emitter terminal still isn’t exactly *common* to ground – however, that amplifier will still function if R_E is eliminated, and in that case we may see how the emitter terminal is common to both input and output voltages.

3.2 Paired transistors

Perhaps the simplest way to combine transistors for greater effect is to *pair* them in such a way that they behave as a single transistor with greater gain. A popular configuration is the *Darlington pair* shown below:

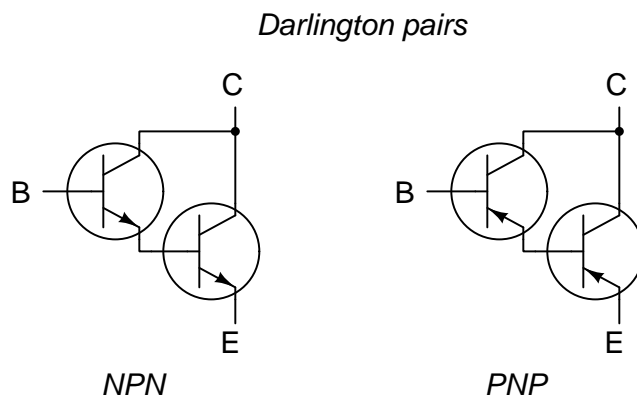

Darlington pairs consist of two similar-type (i.e. both NPN or both PNP) bipolar junction transistors, arranged so that the emitter terminal of the “front” transistor drives the base terminal of the “final” transistor. In this way, the over-all current gain far surpasses the current gain of either transistor separately. For example, a Darlington pair with transistors having individual beta (β) ratios of 100 and 20, respectively, would exhibit an over-all “super-beta” ratio of $(100+1) \times 20 = 2020$.

A popular use for Darlington pairs includes pairing a small-signal transistor (front) with a power transistor (final), since most power transistors have relatively low beta ratios and could benefit from the “super-beta” performance offered by the Darlington pair configuration. It is even possible to combine three or more BJTs in similar fashion for even more current gain.

A variation on this theme is the *Sziklai pair* configuration using complementary BJT types:

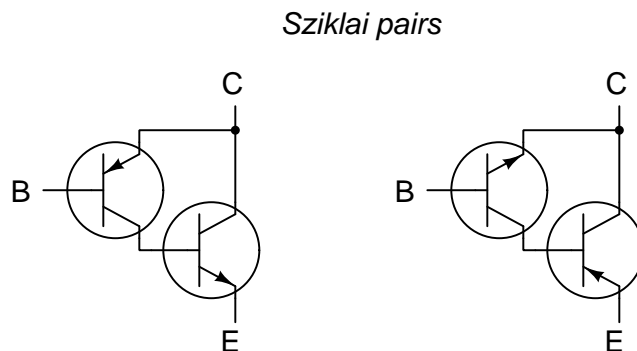

As with most innovations, every new advantageous design usually suffers some disadvantage(s) as well, and Darlington/Sziklai pairs are no exception to this rule. While “stacking” BJTs in this manner offers large increases in effective β , it comes at the price of increased delay and greater effective base-emitter voltage drop. The increased delay time is fairly evident upon inspection: the final transistor cannot turn on or off until the front transistor feeding it turns on or off (respectively), and so the two transistors’ on-delay times and off-delay times add to create greater over-all on-delay times and off-delay times. The increased V_{BE} is also evident if we apply Kirchoff’s Voltage Law to an active Darlington pair:

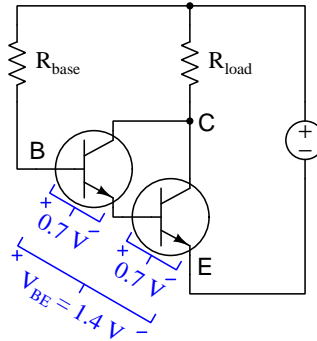

Another (potential) disadvantage with the Darlington pair, more of a concern in on/off switching circuits than analog amplifier circuits, is that the final transistor cannot become saturated fully “on” in the same way the front transistor can. Consider this analysis showing collector-emitter voltage drops in simple transistor switching circuits:

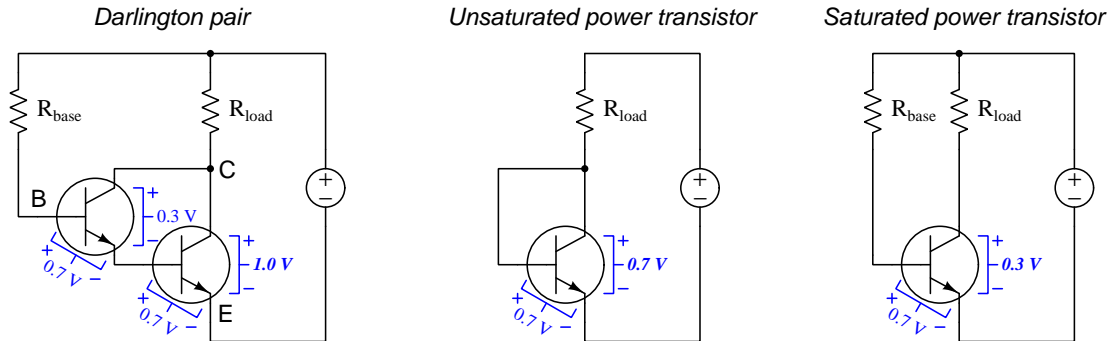

In the Darlington pair circuit, the final (power) transistor must drop more than 0.7 Volts between collector and emitter: its own 0.7 Volt V_{BE} drop *plus* the V_{CE} drop of the front transistor. This additional collector-emitter voltage drop results in more power dissipation at the power transistor for any given amount of collector (load) current. The difference in voltage drop between these three configurations may not seem like much, being mere fractions of a Volt, but as a *percentage* they tell us the unsaturated single-transistor circuit will only dissipate 70% as much heat as the Darlington pair’s power transistor, and the saturated single-transistor circuit will dissipate a mere 30% as much heat as the Darlington pair.

Paired transistors find popular application for power-switching circuits, some manufactured in rather large sizes as transistor *modules*. The following photograph shows one such module, with two Darling-ton-pair transistor arrays contained within:



This particular module has a metal back surface (not visible in the photograph), designed to contact a larger heat sink for power dissipation purposes. Its maximum ratings are impressive: 600 Volts maximum V_{CE} (collector-to-emitter voltage drop), 100 Amperes maximum I_C (collector current), and properly heat-sunk it has a maximum power dissipation rating of 620 Watts.

BJTs designed for high-power applications are notorious for exhibiting low β ratios. When stacked as a Darlington pair, though, the current gains of the two transistors multiply to produce a much larger “super-beta” ratio. This module happens to exhibit a total β ratio in excess of 250 at room temperature and at a collector current of 4 Amperes, far greater than any single BJT could be expected to deliver at these voltage and current ratings. A high β such as this permits the transistor module to control electric power to a large load (e.g. multi-horsepower electric motor) while being “driven” by relatively low-power control signals.

3.3 Cascaded stages

A simple means of employing multiple transistors to create an amplifier with performance ratings exceeding that of a single-transistor amplifier is to cascade entire amplifier sub-circuits to form a *multi-stage* amplifier. The following example shows how this may be done with two common-emitter amplifier stages:

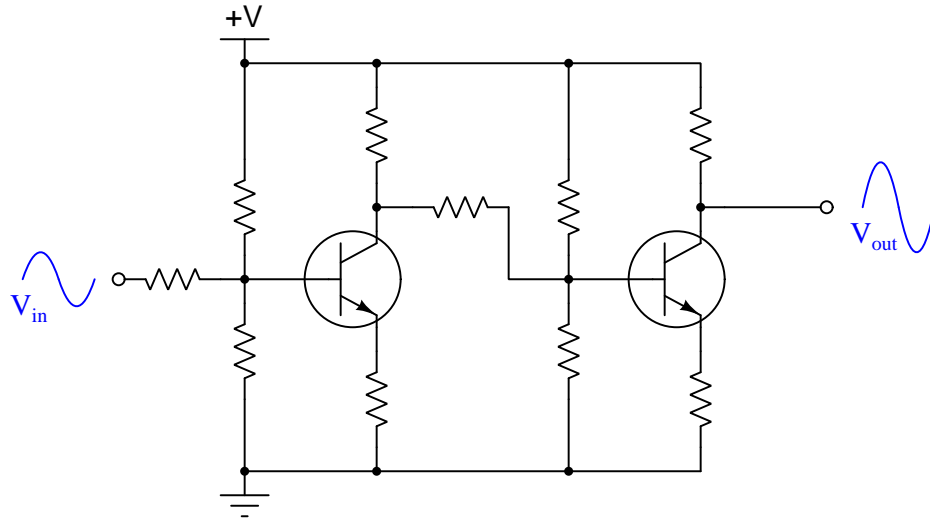

Note the “non-inverting” characteristic of this two-stage amplifier circuit, where the output signal is in-phase with the input signal. Each common-emitter stage has an “inverting” characteristic, and the cascading of these two stages makes the over-all characteristic non-inverting.

The middle resistor in this amplifier – drawn horizontally – serves the purpose of *coupling* the two stages together. This resistive connection between the first and second stages is called *direct coupling* and it allows the over-all amplifier circuit to convey DC signals from input to output. A disadvantage of direct coupling, though, is that any changes or drift in the biasing of one stage will affect the bias of the other stage.

A solution to the problem of interacting biasing is to use some other means of signal-coupling between stages that blocks DC signals. One such solution is to use a capacitor for the task:

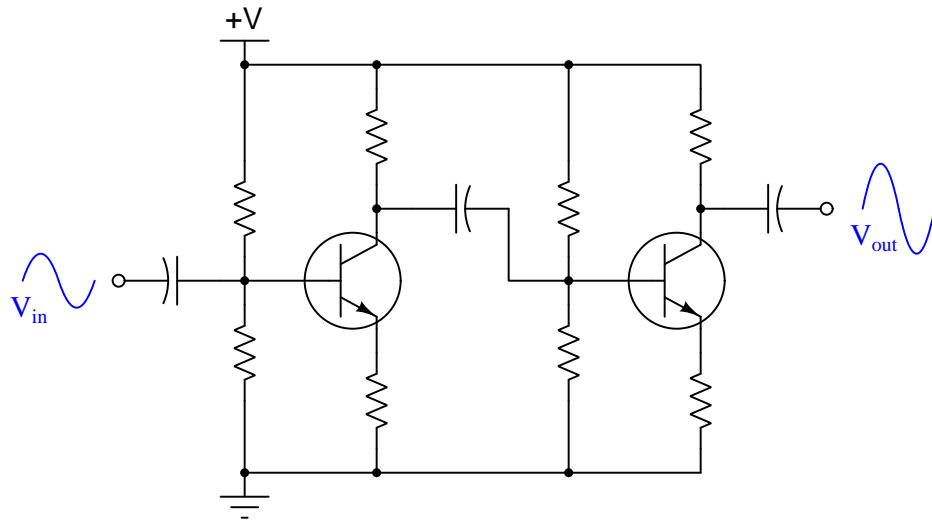

Functioning as a high-pass filter, this capacitor and its surrounding resistances act to couple AC signals from the output of the first stage to the input of the second stage, while blocking any DC (quiescent) signals so that drift in one stage will not upset the biasing of the other. This coupling capacitor's value must be chosen for negligible reactance over the anticipated signal frequency range ($X_C = \frac{1}{2\pi fC}$).

A similar solution utilizes a *signal transformer* to couple the output of the first stage to the input of the second, since transformers operate on the principle of electromagnetic induction which requires a *varying* magnetic field and therefore cannot convey any steady-state signal:

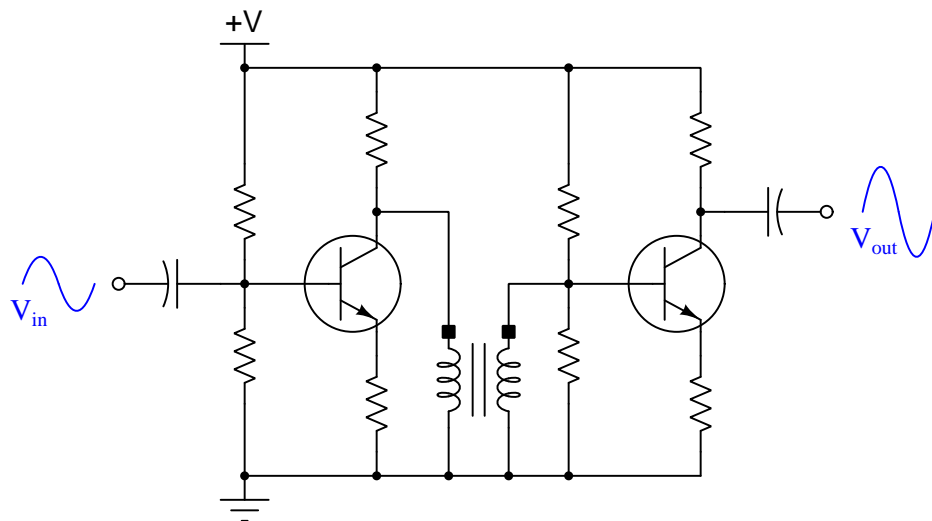

Of course, it is possible to cascade amplifier types other than common-emitter. For example, consider the following two-stage BJT amplifier where a common-emitter first stage cascades to a common-collector second stage, thereby combining the high voltage gain of the C-E configuration with the high current gain of the C-C configuration:

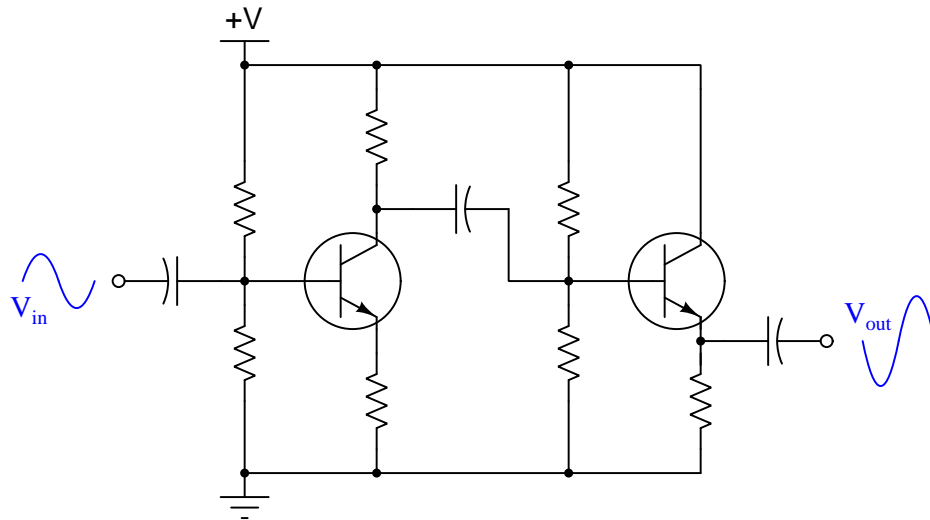

Note how the over-all amplifier's characteristic is *inverting*, since its C-E stage is inverting and its C-C stage is non-inverting.

An interesting multi-stage transistor amplifier commonly used for high-frequency applications is the *cascode* design, combining a common-emitter stage with a common-base stage:

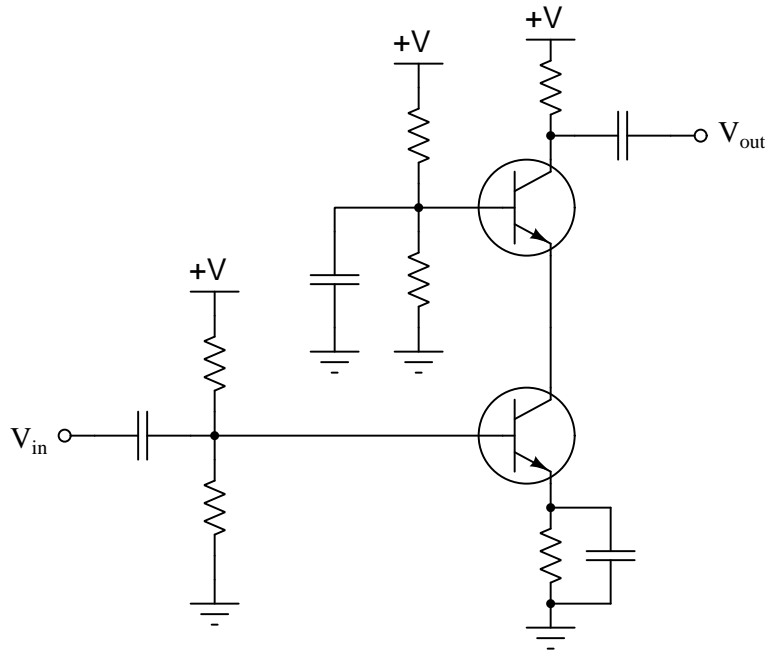

Here the upper transistor is the common-base stage and the lower transistor is the common-emitter (with a bypassed R_E). Common-emitter amplifiers are versatile because they offer both voltage gain and current gain, but at very high frequencies their voltage gains suffer due to the parasitic capacitance between the collector and base terminals acting as a pathway for *negative feedback*². Common-base amplifiers are immune to this effect because their base terminals are essentially grounded and therefore bear no AC signal voltage in reference to ground, and are therefore able to provide high voltage gains even at very high signal frequencies. However, common-base amplifiers always exhibit low current gain, and here is where the common-emitter stage in a cascode amplifier helps: it makes up in current gain what the common-base stage lacks.

Again, this is the very purpose of cascading transistor amplifier stages to make more complex amplifiers: to combine the best features of single-transistor amplifier circuits to form a larger amplifier meeting *all* desired performance criteria.

²This capacitance exists in a BJT operating in its “active” (i.e. current-regulating) mode where the base-emitter junction is reverse-biased and a depletion region exists between those two layers. This capacitance acts as a coupling mechanism for AC signals to pass from the collector terminal to the base terminal, and this natural signal coupling has a diminishing effect on voltage gain because the collector and base terminal voltages (with respect to ground) are inverted from each other. Hence, variations in V_C tend to *counteract* variations in V_B , the result being that the transistor is prevented from “seeing” the full force of the signal applied to the base terminal which in turn diminishes its output signal amplitude. While negative feedback can be a very useful principle, here the natural negative feedback resulting from base-collector capacitance attenuates what could otherwise be a strong voltage gain for the amplifier circuit.

3.4 Push-pull amplifiers

Single-stage transistor amplifiers typically operate as *class-A* circuits, the label “class-A” referring to the fact that the one transistor continuously operates in its “active” mode. This is necessary to maintain signal fidelity. One way to view the transistor’s function in an amplifier circuit is to see it as an active element of a *voltage divider*:

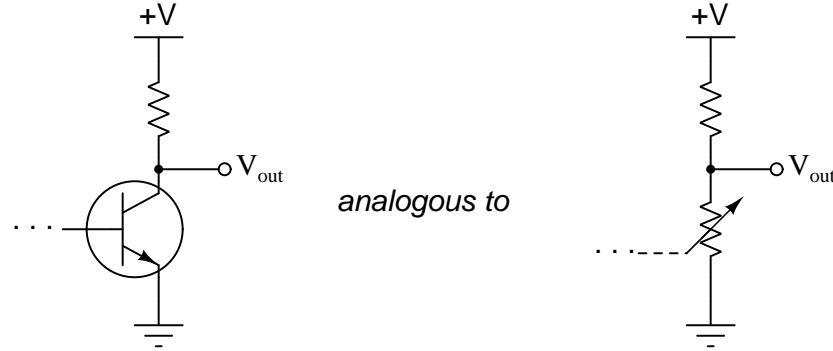

If ever the transistor were to turn fully on (i.e. saturate with respect to base current) or turn fully off (cutoff), the output voltage would reach its limit. This would make it impossible for V_{out} to progress any further, forcing any AC wave-shape extending beyond that limit to become “clipped”.

Clearly, then, class-A operation is necessary for reproducing AC signal wave-shapes through single-transistor amplifiers, and maintaining signal integrity is important for most electronic signal applications. However, maintaining the transistor in a state of electrical conduction throughout the wave’s cycle means some of the power supply’s current does no useful work but rather passes through the transistor and dissipates energy in the form of heat. Thus, class-A amplifier circuits exhibit poor energy efficiency³.

³Efficiency is computed as the ratio of useful outcome to expended effort. For an electronic amplifier, energy efficiency is the ratio of useful energy delivered to the load divided by total energy taken from the DC source.

A related problem of class-A amplification is asymmetrical sourcing and sinking capability. If we view the final common-collector stage of an amplifier circuit when it sources current to a load versus when it sinks current from a load the reason for this asymmetry becomes apparent:

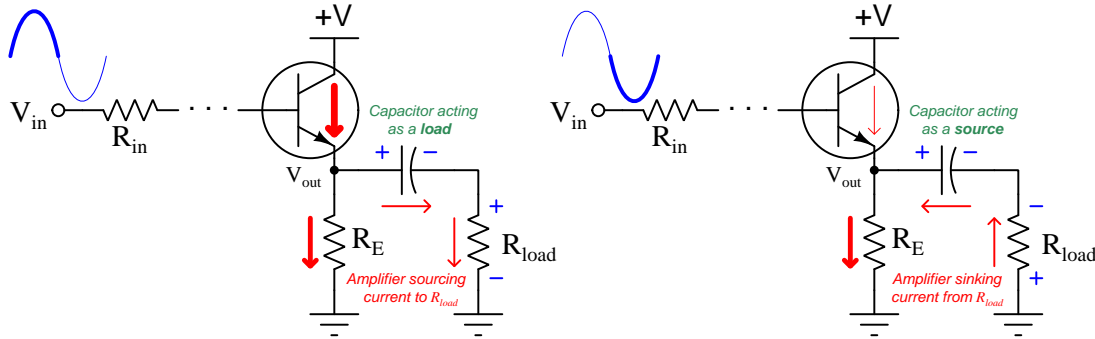

In the left-hand diagram, the input signal is in its positive half-cycle, causing the NPN transistor to become more conductive which increases V_{out} and *sources* current to R_{load} . In the right-hand diagram, the input signal is in its negative half-cycle, causing the NPN transistor to become less conductive which decreases V_{out} and *sinks* current from R_{load} . The transistor, being a modulated (i.e. *electronic*) device, has the ability to vary its conductivity across a wide range, from virtually no resistance to infinite resistance, but in this configuration it can only source current. The emitter resistor, by contrast, always has a fixed resistance value, but can only sink current. With completely different sourcing and sinking mechanisms, a single-transistor amplifier such as this can never “push” and “pull” current equally well: the transistor merely varies the degree to which it “pushes” while the resistor constantly “pulls”.

We may express this asymmetry more precisely by noting the output impedance of this amplifier circuit in each of the half-cycles of the signal waveform. When the transistor is fully on, the load is sourced current by the amplifier with an effective output impedance of $R_E \parallel \frac{R_{in}}{\beta+1}$. If beta (β) is reasonably high, this output impedance will generally be quite small, which means the amplifier acts as a “stiff” voltage source able to output a given voltage with little to impede current sourced to the load. However, when we imagine the transistor turning off to sink as much current from the load (actually, from the output coupling capacitor) as possible, the effective output impedance simply becomes R_E , a larger value than R_E in parallel with $\frac{R_{in}}{\beta+1}$ which was the impedance when the transistor was actively conducting current. In other words, *the amplifier’s output impedance varies with the signal’s value*, and for this reason it cannot sink current as effectively as it can source current. Simply put, this single-transistor amplifier cannot be as “stiff” of a voltage source when sinking current as it is when sourcing current.

When we analyze the effects of this asymmetry on a test signal, we generally find the amplified output signal exhibits *even-numbered harmonics*, especially the second harmonic. Viewed on an oscilloscope, this means one half of the waveform has a slightly different shape than the other half. Viewed on a spectrum analyzer, this means a pure sine-wave input signal (consisting of a single-frequency peak) gets distorted into a spectrum having multiple peaks with a particularly strong second-harmonic peak.

One solution to this problem is a different configuration of amplifier called a *push-pull* using a pair of transistors connected in common-collector fashion, one transistor dedicated to sourcing (“pushing”) current and the other dedicated to sinking (“pulling”) current:

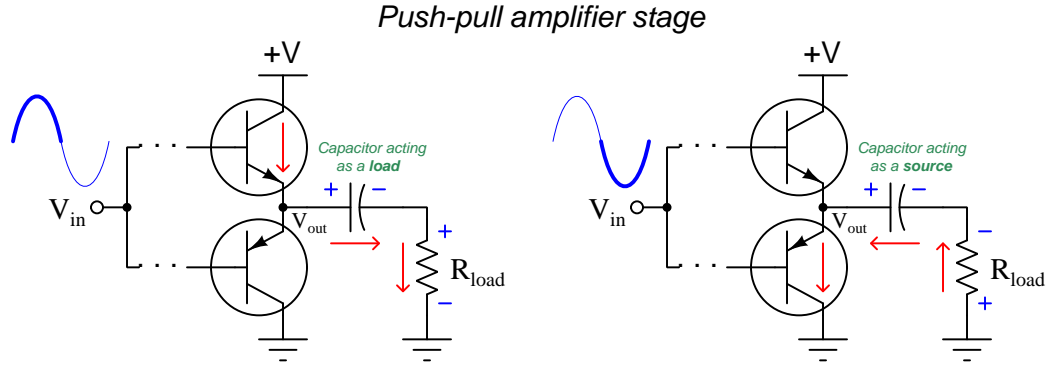

Having two transistors available to alternately source and sink current means we may modify this push-pull amplifier circuit to use a “split” DC power supply and thereby eliminate the need for the output capacitor:

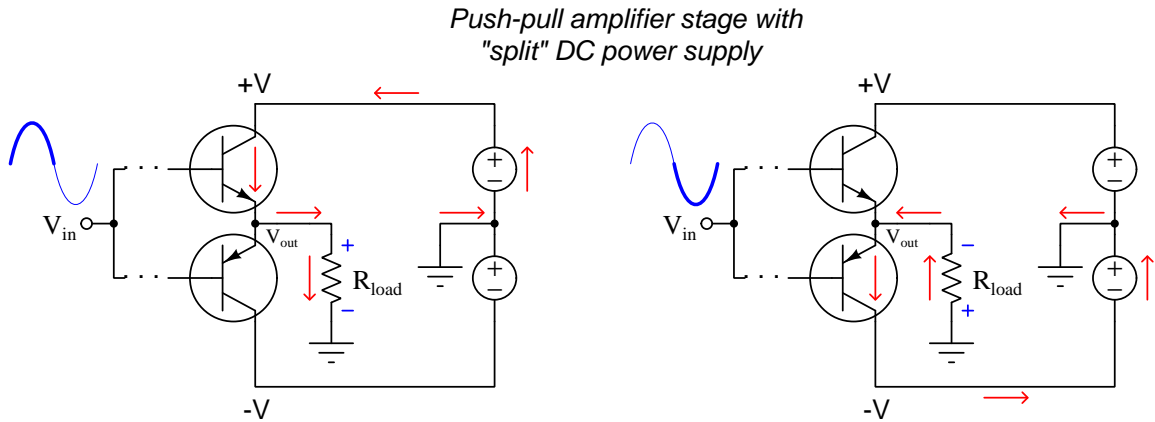

With two transistors working as a complementary pair, one is able to entirely cut off while the other passes only as much current as R_{load} requires at any given time. The amplifier’s output impedance remains constant throughout the signal’s state, and there is also a significant reduction in wasted energy with no current uselessly passing straight from the +V power supply rail to ground.

If we bias the two transistors of a push-pull amplifier such that each conducts exactly half the time (one during the positive half-cycle and the other during the negative half-cycle), we instead say these transistors exhibit *class-B* operation. In class-B operation, the amplifier has symmetrical sourcing and sinking capability, and dissipates less energy in the form of transistor heat than a class-A amplifier.

Not surprisingly, this class-B push-pull amplifier design has its own unique limitations. Chief among them is a problem called *crossover distortion* which occurs if the transistor biasing is imperfect and causes them to conduct less than 50% of the time. This means there will be a brief moment in time during every zero-crossing of the AC signal when neither transistor conducts, and at that time the amplifier neither sources nor sinks current to R_{load} . This naturally happens only at one brief instant in time (the zero-crossing point), but imperfect biasing can cause the push-pull amplifier to remain “off” for slightly longer. The result is a “dead spot” in the output waveform at every zero-crossing. This form of distortion generates *odd-numbered harmonics* in the output signal. A flip-book animation of this phenomenon may be viewed in section 4.2 beginning on page 73.

Achieving class-B operation is a matter of properly biasing the push-pull transistors. The following schematic diagrams show ineffective (left) and effective (right) methods for doing so:

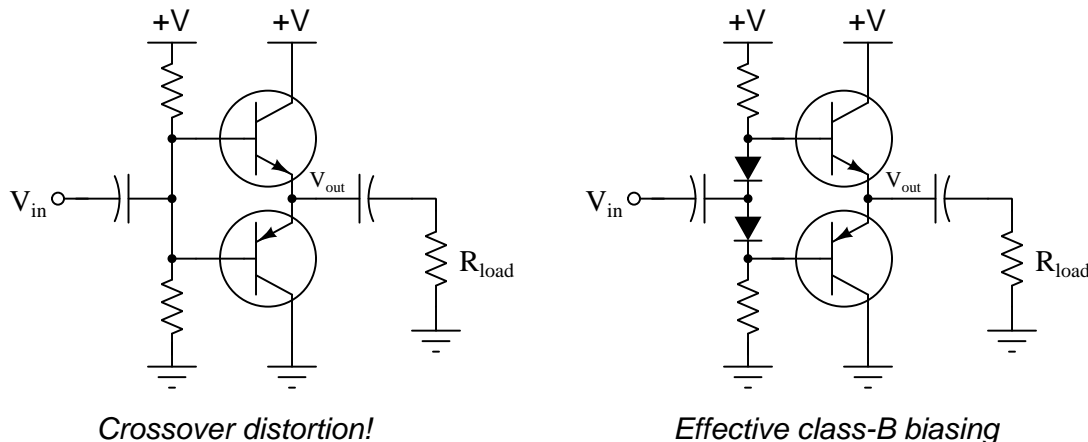

The amplifier on the left is guaranteed to distort the signal because the upper transistor will not begin to conduct until its base rises 0.7 Volts above the output terminal, and the lower transistor will not begin to conduct until that same point’s potential falls 0.7 Volts below the output terminal’s potential. This means the input signal voltage must traverse a “distance” of 1.4 Volts (from +0.7 Volts above V_{out} to -0.7 Volts below V_{out}) while neither transistor conducts. The right-hand amplifier circuit, with its two diodes⁴ inserted in the biasing network, ensures the two transistors’ base terminals always remain approximately 1.4 Volts apart, the upper and lower transistors both ready to conduct at a moment’s notice whenever the input signal rises above or falls below “center”.

In order to further mitigate the “dead spot” resulting in crossover distortion, some push-pull amplifier circuits include an additional source of voltage drop in the biasing network (e.g. a third diode or resistor resulting in slightly more than 1.4 Volts). This ensures the two transistors will never simultaneously turn off, but comes at the price of some simultaneous conduction which wastes

⁴A clever trick to ensure these diodes’ combined voltage drop is (very nearly) equal to the power transistors’ V_{BE} voltage drops is to use identical power transistors as diodes instead of using normal diodes, connecting just their base and emitter terminals and leaving their collectors floating. If this extra pair of power transistors are attached to the same heat sinks as the actual power transistors, their temperatures will be equal and thus their PN-junction voltage drops should be nearly equal as well. Thus, the biasing network will always maintain a comparable voltage drop to that of the two active power transistors’ base-emitter drops under all operating conditions.

energy by passing some current through both transistors (from +V to ground) without doing useful work at the load. This inefficiency is not as bad as class A operation⁵, though, and so we call this slight over-biasing of the push-pull pair *class AB*.

A common variation on this theme uses a current-regulating network⁶ to send a constant current through resistors to create the approximately 1.4 Volt difference necessary between the two power transistors' base terminals:

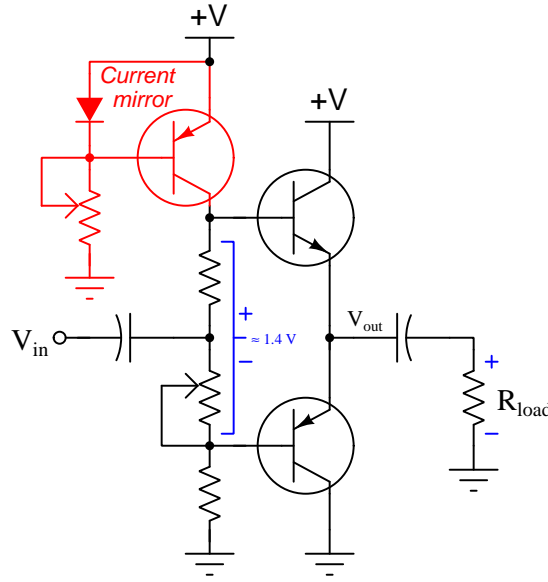

The potentiometer in this circuit acts as a variable resistance that may be adjusted to reduce crossover distortion, setting the bias voltage necessary to achieve good class-B or class-AB operation. A network known as a *current mirror* (described in section 3.6 beginning on page 41) functions to regulate DC current at a fixed value through the two biasing resistors despite any changes in their resistance. This constant-current regulation makes bias voltage directly proportional to the adjusted resistance by Ohm's Law ($V_{bias} = IR_{bias}$).

⁵It should be mentioned that it is actually possible to bias a push-pull amplifier circuit such that it operates in class A mode, although this would be *terribly* inefficient!

⁶In this circuit, the network regulating current through the bias resistors at some fixed value is called a *current mirror*. These are explained in more detail in a future section of this Tutorial. For now, all you need to know is that the current mirror network's transistor works to stabilize DC current at some fixed value despite changes in resistance.

An alternative push-pull amplifier design uses identical power transistors rather than complementary, and uses an additional amplifier stage called a *phase splitter* to drive each of the power transistors:

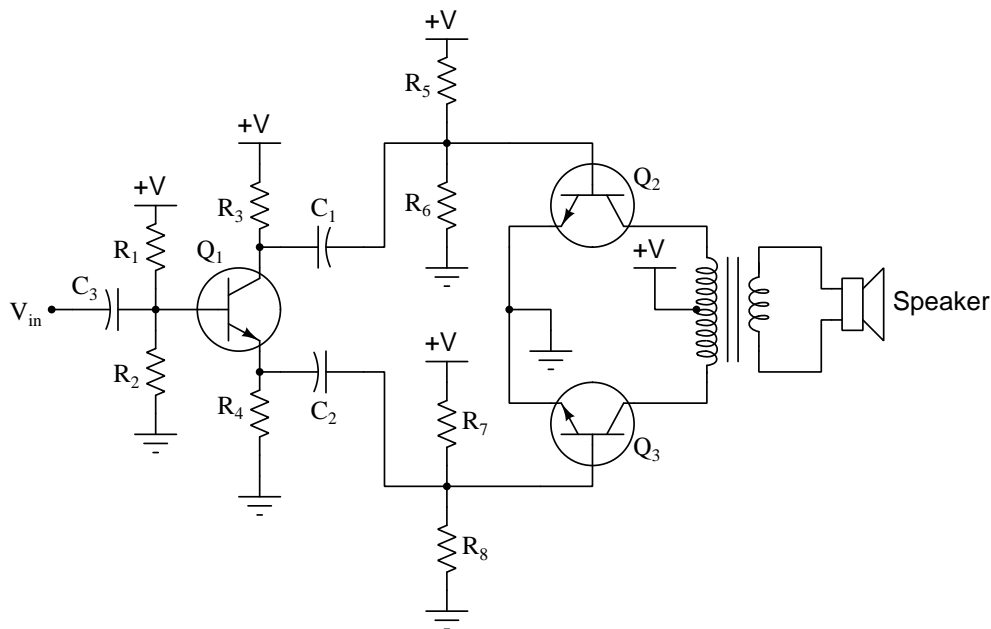

Here, Q_2 and Q_3 are both NPN power transistors, each one driven by signals coming off the collector and emitter terminals, respectively, of transistor Q_1 which operates as the phase splitter with equal-sized resistors R_3 and R_4 . The equal R_3 and R_4 resistor sizes allow Q_1 to operate as a common-collector amplifier (from the perspective of its emitter as the output terminal) and as a common-emitter amplifier (from the perspective of its collector as the output), both having an AC voltage gain of 1. The sole purpose of this “phase-splitting” stage is to generate inverted and non-inverted signal waveforms of equal amplitude to alternately drive the two power transistors. The center-tapped output transformer conveys energy from the primary winding⁷ to the secondary winding to present true AC to the load, in this case an audio speaker. Bias resistors R_1 and R_2 maintain the phase-splitting transistor Q_1 in class-A operation, while bias resistors R_5 and R_6 maintain Q_2 in class B operation, and resistors R_7 and R_8 maintain Q_3 in class B operation as well.

Unlike the complementary (PNP + NPN) push-pull circuits explored previously which are common-collector operating with a voltage gain of nearly one, this circuit’s power transistors are connected in common-emitter configuration⁸ which gives it the ability to have a voltage gain greater than one. It should be noted that the phase-splitter stage must have a voltage gain precisely equal to one (1) in order to drive the two power transistors equally. Any voltage gain offered by this amplifier must come from the power transistors and/or the transformer winding turns ratio.

⁷Actually, one-half of the primary winding at any given moment in time.

⁸In this particular case, *unswamped* common-emitter for maximum voltage gain.

One of the advantages of push-pull power amplification is the ability of the power transistors to periodically turn off rather than to have to conduct current all the time as is the case with single-transistor amplifiers operating in a class A regime. During its “off” time a transistor dissipates no energy because its current is zero, giving it time to cool down from its last period of conduction, as well as reducing total heat dissipation of the amplifier for greater energy efficiency. In class B mode, each of the two power transistors spends exactly half the time on and the other half the time off while amplifying a continuous waveform. In class AB mode this ratio is biased slightly for greater “on” time and lesser “off” time, sacrificing some energy efficiency for reduced crossover distortion.

A design of push-pull power amplifier intended specifically for music reproduction exploits the variations in audio volume typical during most musical recordings, especially⁹ classical (orchestral) music. This design uses four power transistors as well as four DC power supply rail voltages, its operating mode referred to as *class G*:

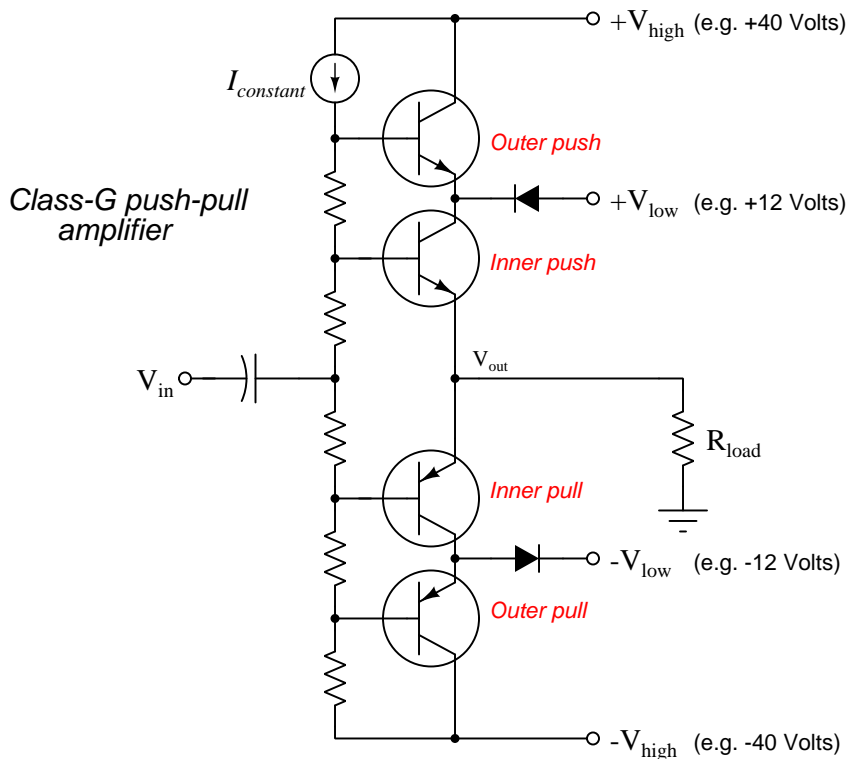

In a class-G amplifier the two “outer” power transistors actually spend the majority of their

⁹Many forms of modern music have their volume *compressed* during the *mastering* step of the production process, whereby the variations in volume between quieter and louder portions of a performance are artificially minimized. In other words, compression automatically increases gain during quieter periods and decreases gain during louder periods, so that the end-result is a recording with a more-constant volume from start to finish. This is typically done with rock music to enhance its perceived loudness. Lesser degrees of compression are usually applied to speech recordings, to aid in legibility as the speaker’s vocal volume (as well as mouth-to-microphone distance) naturally varies.

time completely off¹⁰, only turning on when necessary to aid the “inner” power transistors to source current to or sink current from the load. Meanwhile, the inner transistors operate from a relatively low-voltage set of DC power supply rails which means they don’t have to drop as much voltage and therefore dissipate less energy in heat. When amplifying music at low volumes, the two inner transistors do all the work while the outer transistors remain in their idle (off) states. Only when the music volume peaks do the outer transistors begin to turn on to provide elevated rail voltages to the inner transistors.

¹⁰This is also known as *class C* operation, and so this “class G” amplifier could be alternatively designated as a “class-BC” amplifier because the outer transistors operate in class C mode while the inner transistors operate in class B.

3.5 Differential pairs

Another type of amplifier circuit utilizing multiple transistors is called a *differential pair*. This amplifier is unique in that it receives *two* input signals rather than just one. A differential pair using two NPN transistors is shown here:

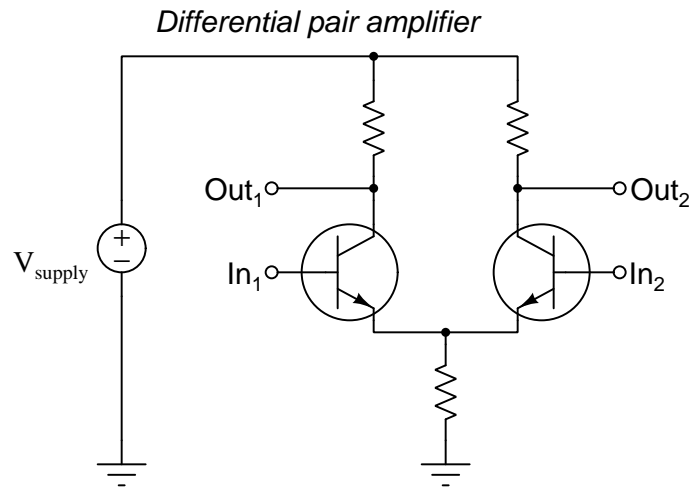

This circuit is really nothing more than two common-emitter amplifiers with a shared emitter resistor. In fact, if one input is left floating (i.e. not connected to anything) the other input and its respective output terminal is just that: a simple common-emitter amplifier with a voltage gain approximately equal to $\frac{R_C}{R_E}$:

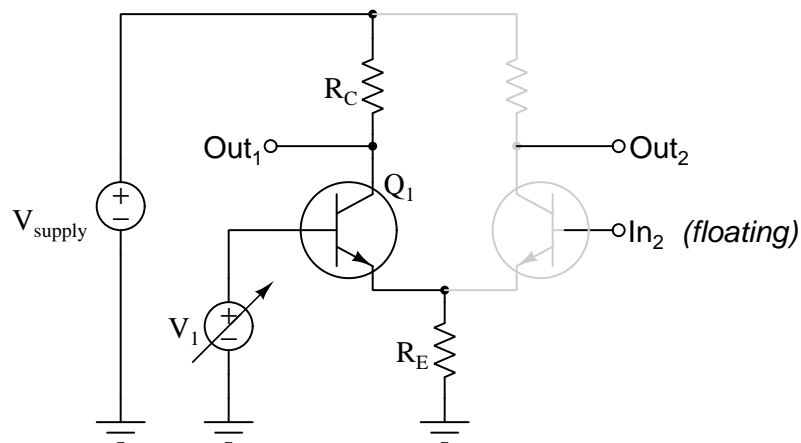

As V_1 increases, transistor Q_1 turns on to a greater degree, passing more current. This increases the voltage dropped across both R_E and R_C , and with R_C dropping more voltage the output terminal experiences less voltage with respect to ground (applying Kirchhoff's Voltage Law with V_{supply} assumed to be constant). In other words, V_1 has an *inverting* effect on the voltage at terminal Out_1 ,

just as we would expect for a common-emitter amplifier. With In_2 floating, the other transistor is fully “off” and passes no current, leaving Out_2 at full supply potential and unaffected by V_1 .

If, however, we connect a fixed-voltage signal source to the second input terminal (of sufficient magnitude to partially turn on transistor Q_2) and re-run our “thought experiment”, we see something more interesting behavior from this differential pair circuit:

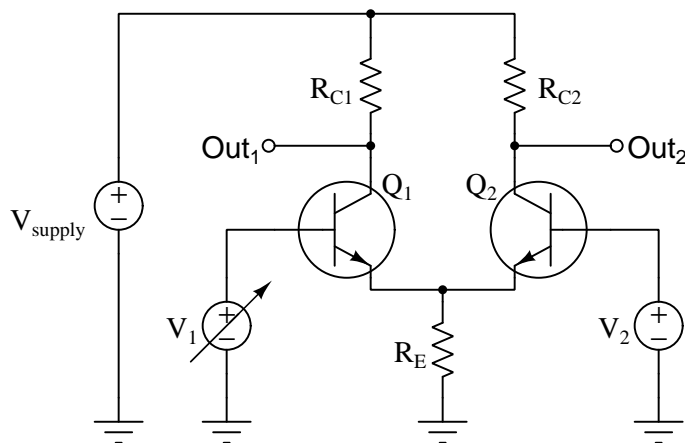

As V_1 increases, transistor Q_1 again turns on to a greater degree, increasing voltage drops across R_E and R_{C1} and consequently causing Out_1 's terminal voltage to decrease as before. The increased voltage drop across the shared emitter resistor, however, now affects the other transistor (Q_2) because it has been biased by V_2 to be partially on. With V_2 fixed, an increased voltage drop across R_E leaves less voltage to forward-bias Q_2 's base-emitter junction (once again applying Kirchhoff's Voltage Law). This causes transistor Q_2 's to restrict collector current, which in turn causes R_{C2} to drop less current and makes the potential at Out_2 increase. In summary, an increase at V_1 causes Out_1 's voltage to decrease and Out_2 's voltage to increase, all voltages measured with respect to ground).

Examining the interaction between the two halves of the differential pair circuit with greater scrutiny, we will find it helpful to characterize transistors Q_1 and Q_2 in terms of “common” amplifier configurations. We have already noted Q_1 functions as a common-emitter amplifier *from the perspective of terminal Out_1* . However, from the perspective of terminal Out_2 it is a much more complex relationship. In our thought experiment we left input voltage V_2 at some fixed magnitude sufficient to make Q_2 partially conduct, which makes V_2 a bias voltage for Q_2 . We also noted that changes in voltage dropped across R_E caused by changes in input signal V_1 affected Q_2 . From the perspective of R_E , transistor Q_1 is a *common-collector* amplifier for signal V_1 , also known as a *voltage follower*: as V_1 increases, V_{RE} increases by an almost identical amount. This increased voltage drop across R_E as a result of V_1 increasing acts as an input signal to transistor Q_2 . With V_2 acting as a constant “bias” and V_{RE} acting as an input signal for Q_2 , transistor Q_2 functions as a *common-base* amplifier from the perspective of output terminal Out_2 . Recall that common-base amplifiers are noninverting and have voltage gains approximately equal to $\frac{R_C}{R_E}$ (the same as common-emitter amplifiers). Therefore, we would expect Out_2 's voltage to rise as much as Out_1 's signal falls for any increase in V_1 . Since the two halves of the differential pair are symmetrical (i.e. identical transistors and collector resistors), fixing V_1 and varying V_2 should manifest the exact same effects, except on *opposite* output terminals.

Illustrating the effects of input voltage changes on the two output signal voltages for a differential pair, using up and down arrows to represent increase and decrease, respectively:

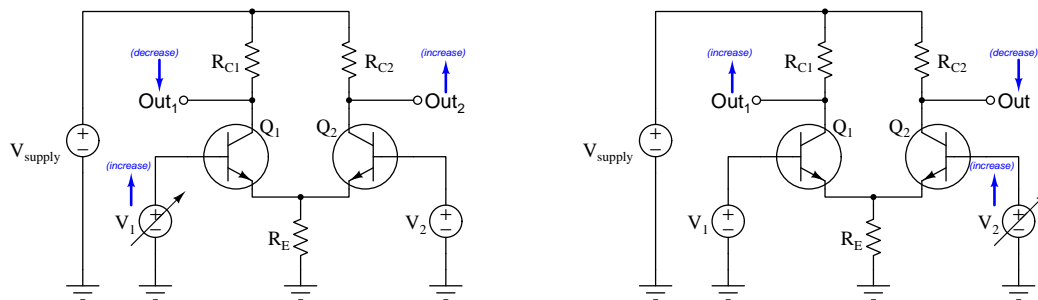

Differential-pair amplifiers usually provide just one output terminal, the inputs labeled *inverting* and *noninverting* in honor of their effects on that single output. When cascaded to additional amplifier stages for greater voltage gain, differential pair amplifiers become so useful that they merit their own schematic diagram symbol – a triangle shape with + and – labels marking the noninverting and inverting input terminals, respectively:

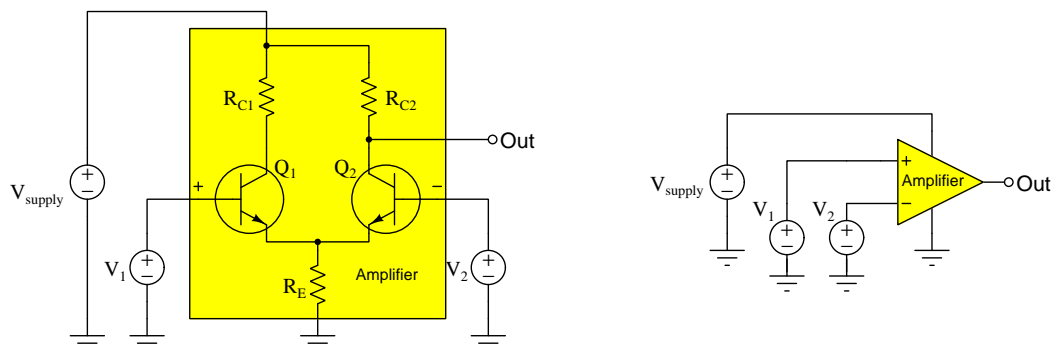

If designed to operate in saturated mode (i.e. the output voltage switches between fully positive and fully negative depending on which input signal is greater) this circuit is called a *comparator*. If designed to operate in active mode where the output voltage is an analog signal capable of varying continuously between the power supply “rail” limits, it is called an *operational amplifier*. The same triangle symbol represents both types of differential amplifiers.

Both comparators and operational amplifiers commonly exhibit incredibly high voltage gains. For a comparator this makes immediate sense: we need the differential voltage gain to be very large in order to force its output voltage to saturate fully + or fully – with the slightest difference in voltage between the inverting and noninverting input terminals. Although a high differential voltage gain may not be immediately appreciated for operational amplifiers, it will be seen later that this is an extremely valuable property because it allows us to employ *negative feedback* to achieve extremely precise amplification.

3.6 Current mirrors

A type of BJT circuit useful for enhancing the performance of general-purpose amplifier circuits and interesting in its own right is the *current mirror*, so-called because one of its transistors acts to regulate current through it to a value matching the current sent through the other transistor. An elementary form of current mirror circuit uses a diode and bipolar junction transistor thermally bonded to each other as shown in the following schematic diagram:

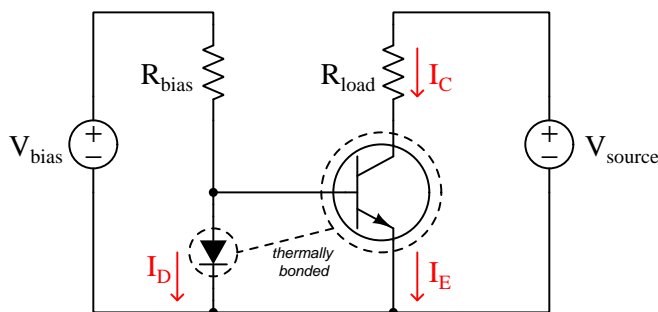

Current mirror circuits exploit the *Shockley diode equation*, which describes the amount of current passing through a PN junction as a function of voltage and temperature:

$$I = I_S \left(e^{\frac{qV}{nKT}} - 1 \right)$$

Where,

I = Forward-bias current through the diode, Amperes

I_S = Reverse-bias saturation current¹¹ through the diode, Amperes

e = Euler's constant (≈ 2.71828)

V = Voltage applied to the PN junction externally, Volts

q = Elementary charge of an electron (1.602×10^{-19} Coulombs)

n = Ideality factor (1 for a perfect junction)

k = Boltzmann's constant ($1.3806504 \times 10^{-23}$ J / K)

T = Absolute temperature (Kelvin), 273.15 more than degrees Celsius

In the current mirror circuit shown, the diode's PN junction is connected in parallel with the transistor's base-emitter PN junction, which ensures those two semiconductor junctions experience the exact same voltage. The fact that they are thermally bonded to each other ensures they experience the exact same temperature too. If all other factors are equal (which may be ensured by careful manufacturing of the integrated circuit on a common silicon die), this means the amount of current through each of those junctions must be equal as well as described by the Shockley diode equation. The diode's current (I_D) is a function of V_{bias} and R_{bias} , which means load current (I_{load})

¹¹A very small amount of current will still flow in the reverse-biased condition, due to so-called *minority carriers* in the P and N halves of the diode. This tiny current, usually in the range of *nano-Amperes* is referred to as the *reverse saturation current* because its value does not increase appreciably with greater reverse-bias voltage but rather "saturates" or "plateaus" at a constant value. This saturation current, while fairly independent of applied voltage, varies greatly with changes in device *temperature*.

will be regulated by the transistor at that same value. Thus, load current follows or “mirrors” the diode’s current.

A practical modification to this circuit replaces the diode with a transistor identical to the first. The new transistor’s base and collector terminals are “short-circuited” by a jumper wire so that only its base-emitter junction is active, ensuring it will function purely as a diode with properties identical to the other transistor’s base-emitter junction. As with the simpler diode-based current mirror circuit, $I_{load} \approx I_{pgm}$ load despite changes in load resistance and/or V_{source} :

A current mirror circuit

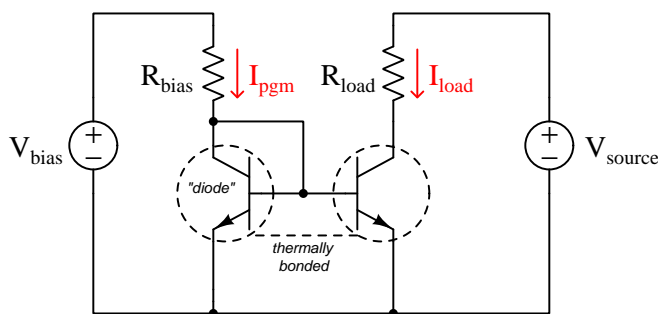

A SPICE analysis shows load voltage as a function of V_{supply} over a range of 0 to 20 Volts:

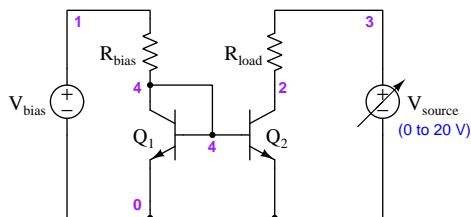

```
* Current mirror
vsouce 3 0 dc
vbias 1 0 dc 5
rbias 1 4 1000
q1 4 4 0 bjt
q2 2 4 0 bjt
rload 3 2 2200
.model bjt npn
+ is=15f bf=220
.dc vsouce 0 20 0.1
.print dc v(3,2)
.end
```

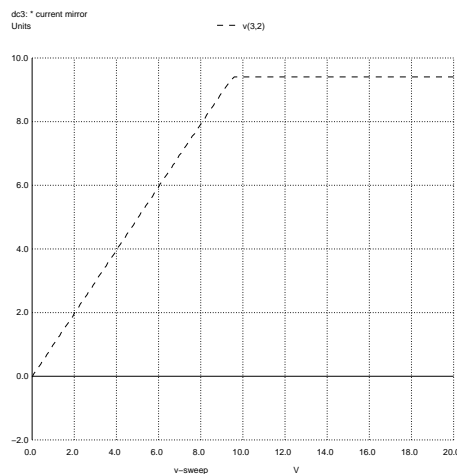

Note how the plot climbs linearly as V_{supply} increases from 0 Volts to approximately 9.5 Volts, but then suddenly levels off. This level portion of the curve shows load current being regulated at a constant value. The fact that load resistor voltage (and therefore load resistor current) is constant only after the supply voltage reaches a certain minimum value is worthy of discussion. A current mirror circuit is not a true *source* in that the transistors cannot provide energy to motivate current through the load. All Q_2 is able to do is *restrict* current to the “programmed” value, with V_{source}

being the actual energy source for this current. With a V_{bias} of 5 Volts and R_{bias} of 1 k Ω , the “programming” current will be approximately 4.3 mA. Mirrored by transistor Q_2 , 4.3 mA becomes the load current value as well, and with a 2.2 k Ω load resistance value this requires an absolute minimum of 9.46 Volts supplied by V_{supply} ($V = IR = (4.3 \text{ mA})(2200 \Omega) = 9.46 \text{ V}$). Any amount of source voltage in excess of 9.46 Volts will be dropped across the collector-emitter terminals of Q_2 as it regulates load current at 4.3 mA and the load drops a constant 9.46 Volts.

If a set of BJTs are constructed on an integrated circuit with paralleled base and emitter terminals, one programming current is able to set the regulation value for an arbitrary number of loads. With each regulating transistor receiving the exact same base-emitter voltage as dropped by the “diode” transistor, each load’s current will be regulated to that same “programming” current value:

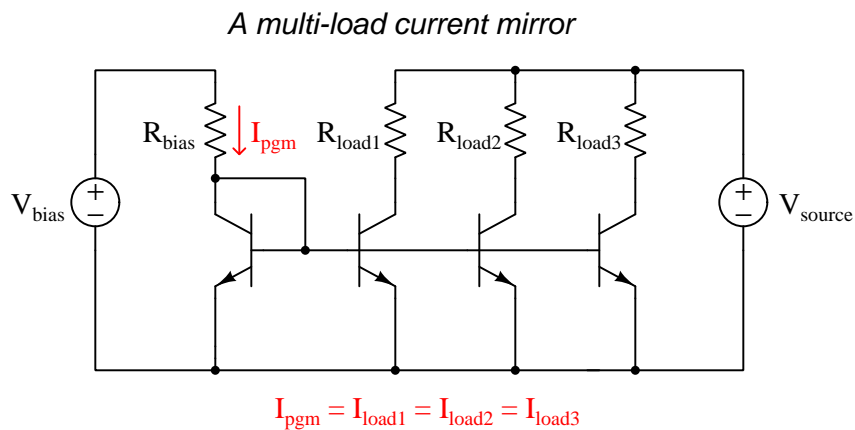

BJT current mirrors may be made in both *sourcing* and *sinking* versions, to suit different loads:

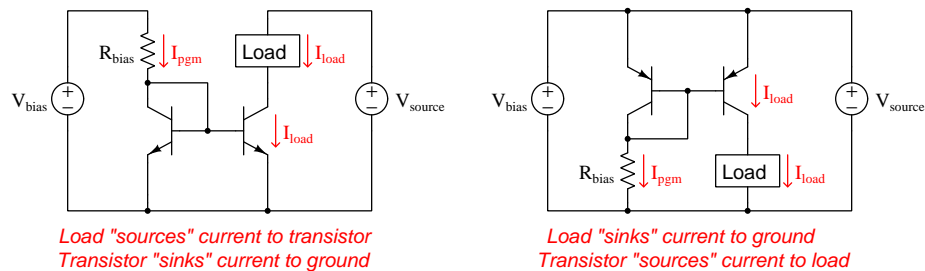

Many different variations of current mirror circuits exist. Below is one such variant, using *two* bipolar junction transistors connected as simple diode PN junctions to establish a near-constant voltage reference which then drive the current-regulating transistor in conjunction with a resistor (R_{set}) to establish the programmed current value:

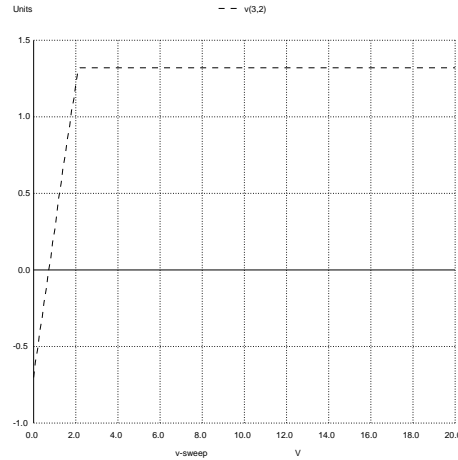
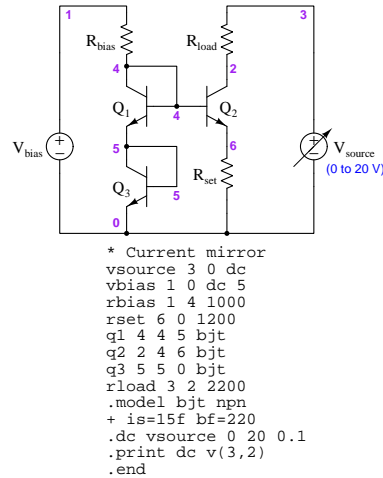

In this simulation the value of R_{set} is 1200 Ohms, and it should see approximately the same voltage drop that exists across transistor Q_3 (functioning as a simple PN diode junction). That (approximate) 0.7 Volt drop divided by 1200 Ohms yields an expected Q_2 emitter current of 583.33 microAmperes, which when passing through the load resistance value of 2200 Ohms should drop approximately 1.2833 Volts between nodes 3 and 2. The SPICE simulation reports R_{load} 's voltage as 1.322 Volts which is fairly close to that predicted value, and most importantly this 1.322 Volt drop is constant over a wide range of V_{source} 's 0-20 Volt sweep, thereby proving the current-regulating characteristic of this circuit.

One advantage of this current mirror circuit over the elementary version shown at first is that this one is less dependent on precise matching between the current-regulating transistor (Q_2) and the first transistor-diode (Q_1) to achieve equality between the program and load currents. In the resistor-based current mirror the load current depends largely on the voltage of transistor-diode Q_2 and resistor R_{set} rather than depending on two transistors having precisely equal characteristics.

Another current mirror design variation is the *Wilson current mirror*, named after its inventor George R. Wilson. In this design an extra transistor is added to the elementary current mirror form with the intention of minimizing the circuit's *static error*, defined as the difference between program current and load current:

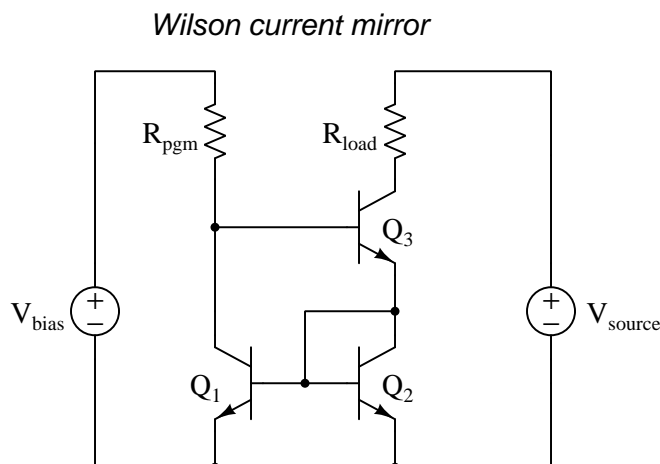

An easy way¹² to analyze this circuit and contrast it against our elementary current mirror is to assume all its transistors have $\beta + 1$ values of 100 so that 1 microAmpere of base current guarantees 100 microAmperes of emitter current (i.e. a beta value of 99). This makes most of the current values whole-numbers and the mathematical relationships therefore easier to see:

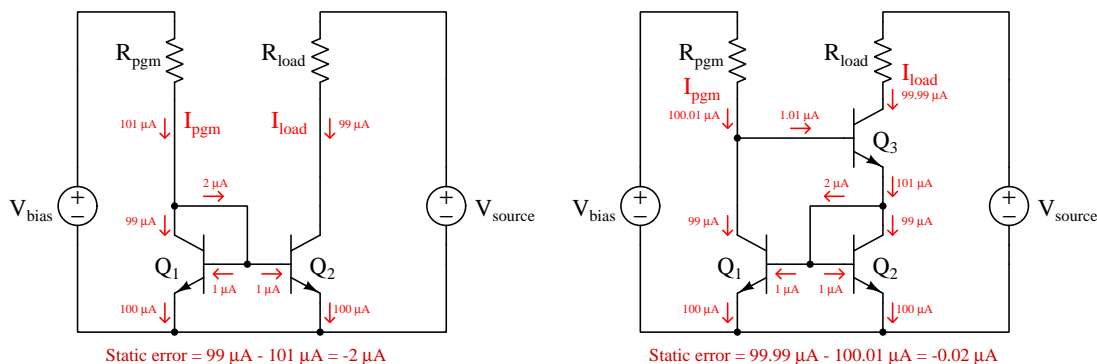

Comparing the elementary current mirror's static error (left) against the Wilson current mirror's (right), we see that the addition of the third transistor to the Wilson current mirror circuit reduces static error by a factor of $\beta + 1$ over the elementary version. Even if Q_3 's beta were not equal to the other transistors', its contribution to the circuit would still dramatically improve performance!

¹²The rationale behind this problem-solving technique is to permit whole-numbered mental calculations of base, emitter, and collector currents at transistors Q_1 and Q_2 , so that our subsequent application of Kirchhoff's Current Law to calculate program and load currents would also be simplified. We could have used *any* beta values and *any* current values at all to prove the concept, but these particular values are just easier to compute.

3.7 Active loading

Simple transistor amplifiers such as the *common-emitter* configuration achieve voltage gain by passing a controlled current through one or more fixed resistances. In the case of a swamped-emitter common-emitter amplifier, the voltage gain will be approximately equal to the ratio of collector to emitter resistance ($\frac{R_C}{R_E}$):

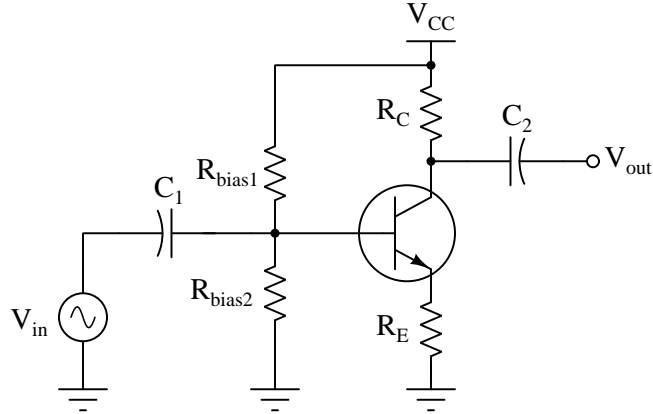

Practical considerations limit the range of resistor values one may use in such an amplifier. Voltage gain is not the only consideration in an amplifier's design, and choosing R_C values that are too large and/or R_E values that are too small in an effort to maximize voltage gain will at some point make stable biasing of the amplifier (for a particular class of operation such as class-A) difficult if not impossible.

If we substitute a *current regulator* in place of the fixed-value collector resistor, we will find that voltage gain may be dramatically boosted while maintaining reasonable quiescent (DC) currents necessary for good biasing. Compare the following schematic diagrams:

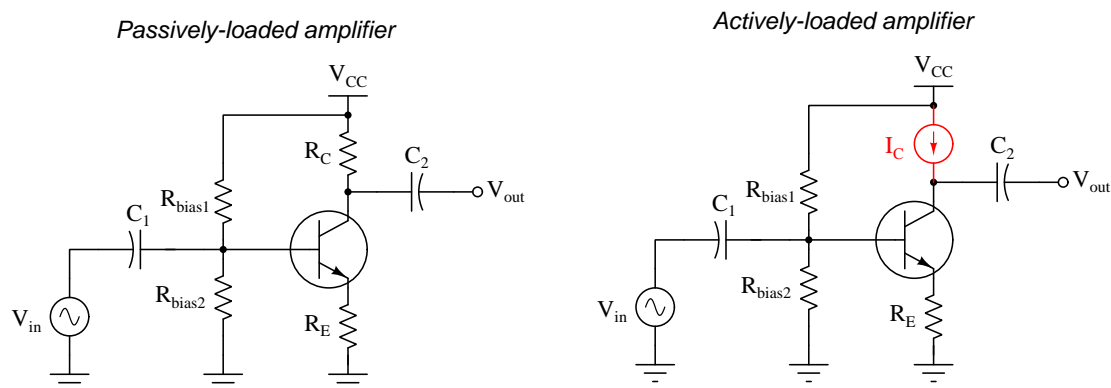

The gain-boosting behavior of the current regulator (I_C) becomes apparent if we run a simple thought experiment: imagine V_{in} increasing in a positive direction such that it turns on each transistor more than they were before. This input stimulus, of course, injects more charge carriers into the base region of both transistors and makes them more conductive. In the passively-loaded circuit this additional conductivity allows greater collector current, which in turn drops proportionately more voltage across R_C and causes V_{out} to fall closer to ground potential, as one would expect with an amplifier having an “inverting” characteristic. In the actively-loaded circuit, however, the current regulator (I_C) opposes any increase in collector current caused by increased transistor conductivity, and *does so by effectively acting as an extremely high resistance value*. As a result of this active opposition to changes in collector current, the actively-loaded amplifier exhibits a much sharper decrease in V_{out} than the passively-loaded circuit. That is to say, the same V_{in} increase to both amplifiers results in a much larger V_{out} change in the actively-loaded circuit than in the passively-loaded circuit; i.e. the actively-loaded circuit has a much greater voltage gain.

We see the same gain-boosting characteristic if we run another “thought experiment” by which we decrease V_{in} for both amplifiers. In both cases this makes the transistors less conductive and causes V_{out} to rise. However, this V_{out} increase is more pronounced in the actively-loaded amplifier because once again the current regulator (I_C) opposes any attempt to change collector current, this time by effectively acting as a very low resistance value in an effort to maintain collector current at its former (higher) value. By doing so, V_{out} rises much closer to full V_{CC} potential than in the passively-loaded circuit, which merely follows Ohm’s Law with the fixed-value R_C .

Another way to grasp the behavior of active loading in a transistor amplifier circuit is to envision the current-regulator as a self-adjusting resistance within a voltage divider, the other major resistance in that divider being the amplifying transistor itself. If the passively-loaded amplifier is analogous to a voltage divider with one variable resistance, then the actively-loaded amplifier is analogous to a voltage divider with *two* variable resistances:

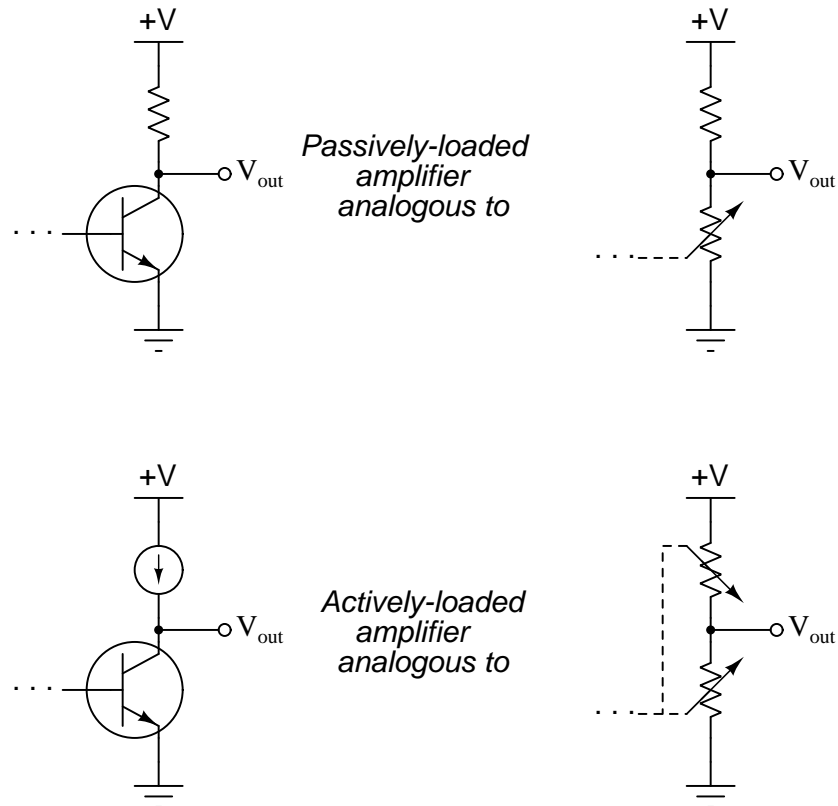

The current regulator's effective resistance complements the effective resistance of the transistor: when the transistor acts to pass more current, the current regulator fights back by trying to hold current at the same value, which is to say passing less current than the transistor desires.

Fulfilling the role of current regulator in an actively-loaded amplifier is usually a *current mirror* such as that shown below:

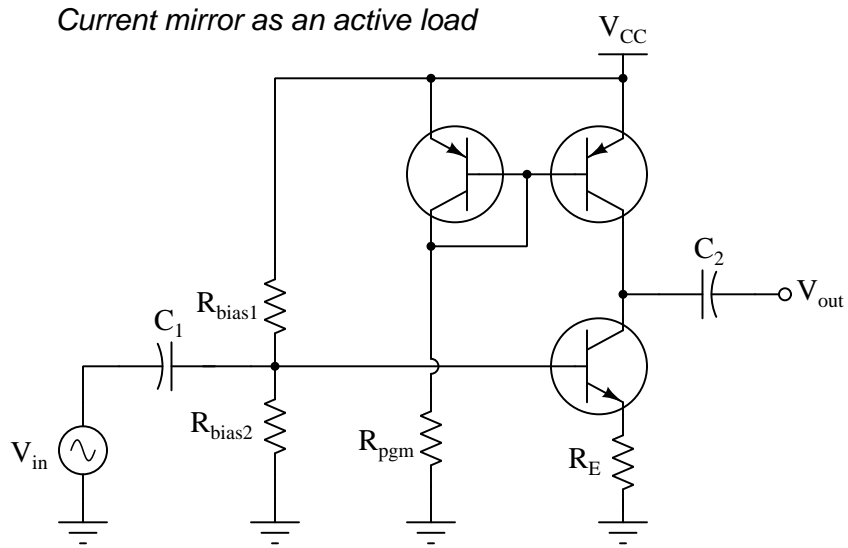

Here, the “programming” resistor R_{pgm} becomes an essential element of the amplifier’s biasing, as it directly controls the quiescent collector current value of the amplifying transistor.

Differential-pair amplifiers benefit greatly from active loading. Plain differential pair circuits such as those shown in the previous section exhibit poor common-mode rejection¹³, and have voltage gain values too low to be immediately useful as either comparators or as operational amplifiers. The circuit's performance is usually augmented by *current mirrors* as shown in the next schematic, and to facilitate good matching between all the transistor pairs the circuit is usually fashioned on an *integrated circuit* (IC) on a single wafer of silicon:

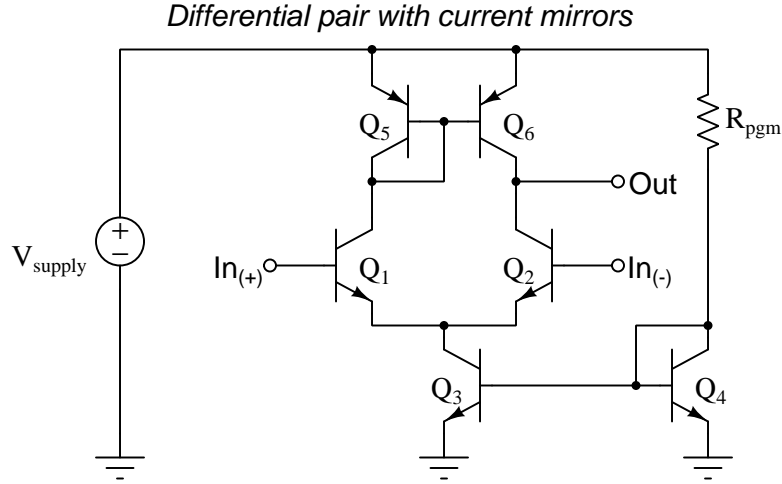

Current passing through the “programming” resistor R_{pgm} creates a voltage drop across Q_4 's base-emitter PN junction which biases Q_3 , causing the latter transistor to function as a current regulator passing approximately the same amount of current as through R_{pgm} . With a nearly constant current assured through Q_3 , any variations in current through Q_1 and Q_2 are forced to be complementary by Kirchhoff's Current Law. If a rise in voltage at $In_{(+)}$ causes current to rise through Q_1 , Q_3 's tendency to regulate current means Q_2 will be *robbed* of current by the same degree, forcing a more pronounced effect at the Out terminal.

The current mirror formed by Q_5 and Q_6 enhance differential voltage gain even more by accentuating the effects of any imbalance in voltage signals between $In_{(+)}$ and $In_{(-)}$. Once again imagining a rise in voltage at $In_{(+)}$ with respect to ground causing Q_1 's current to increase, Q_6 will try to match that current increase through Q_2 by becoming more conductive. This, on its own, will force the output voltage to rise even without any response from Q_2 . Putting all these effects together results in a differential pair circuit with far greater differential voltage gain than before.

¹³An ideal differential-input amplifier responds only to the *differential voltage* between its two input terminals, and not to the *common-mode voltage* between either terminal and ground. However, the simple differential pair is unfortunately affected by both which means it does a poor job of rejecting (i.e. ignoring) changes in common-mode voltage while responding to differential signals.

In an effort to decrease input bias current we may replace transistors Q_1 and Q_2 with *Darlington pairs*, which is often how we find the input stages of IC comparators and operational amplifiers constructed:

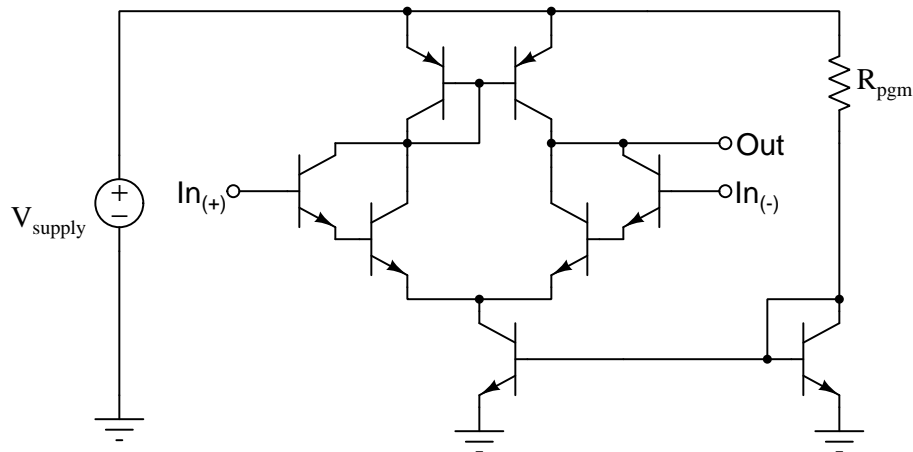

Additionally, single-ended amplifier stages may be added to this circuit to increase voltage gain and output current-drive ability. When one examines the internal circuitry of comparators and operational amplifiers alike, we always find additional stages of amplification beyond the augmented differential pair. Consider for example the model 339 comparator:

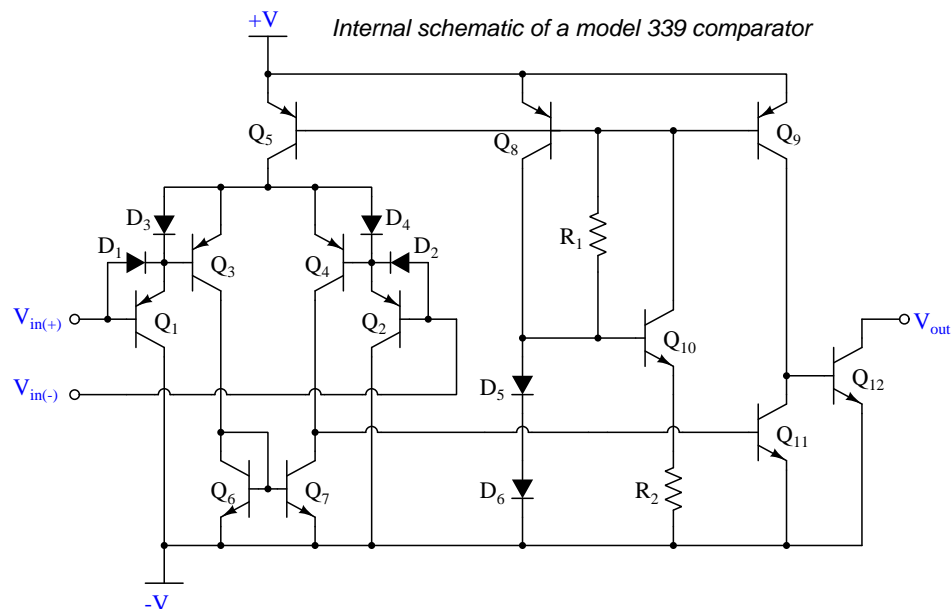

Here, the augmented differential pair embodies most of the comparator (Q_1 through Q_7). The gain-boosting and output drive stages are found in transistors Q_9 , Q_{11} , and Q_{12} . "Programming" of

fixed-current regulation is the responsibility of diodes D_5 and D_6 , transistor Q_{10} , and resistor R_2 , the two diodes forming an (approximate) 1.4 Volt drop which together with the 0.7 Volt base-emitter drop of transistor Q_{10} establishes a constant voltage across resistor R_2 . That, in turn, “programs” a constant collector current through Q_{10} which is split three ways through the bases of transistors Q_5 , Q_8 , and Q_9 .

Examining a more sophisticated differential amplifier circuit next, we see a schematic diagram for the venerable model 741 operational amplifier:

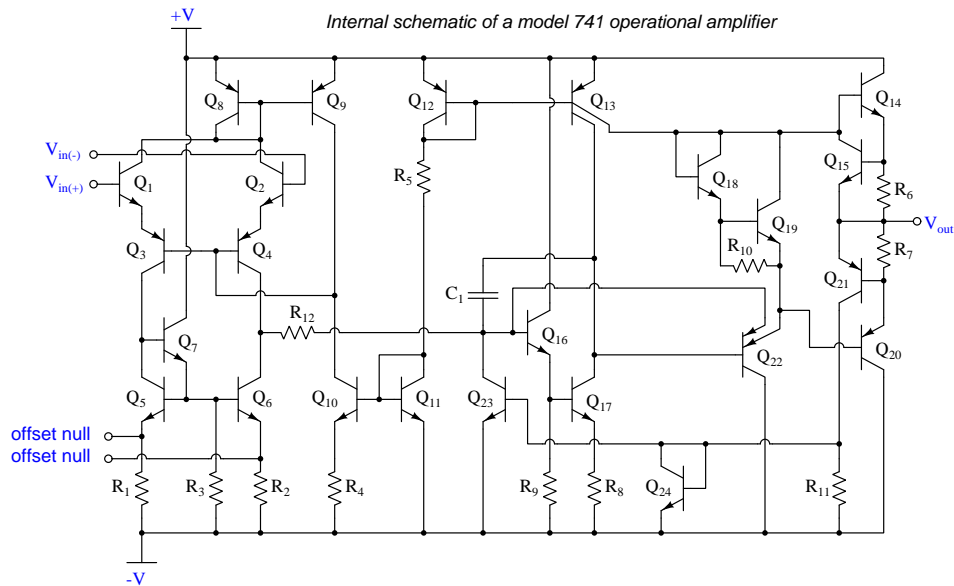

The long horizontal wire connecting to the base of Q_{16} is what bridges the differential input stage to the gain-boosting stage. The final output stage consists of the four transistors to the far-right of the diagram. Current-mirror programming is primarily the function of resistor R_5 .

3.8 Typical audio power amplifier design

Amplifiers intended to boost signal power for the purpose of audio reproduction are commonly found in consumer electronic devices such as portable radios, stereo and home entertainment systems, etc. While many different design variations exist, a common topology¹⁴ consists of three distinct amplifier stages coupled together. A typical audio power amplifier is shown below in block-diagram form:

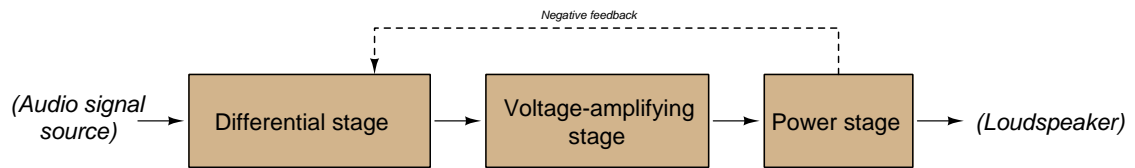

A simplified schematic-diagram version appears next:

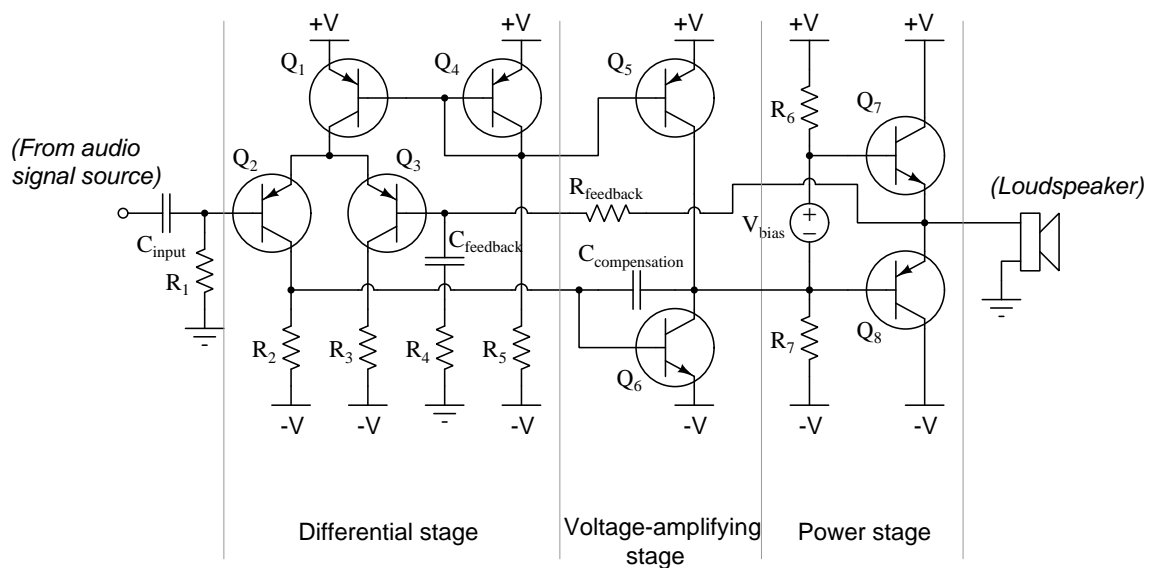

Note the incorporation of several amplifier concepts in this one circuit:

- Differential pair (Q_2 and Q_3) amplifies the difference between the audio input signal and the “feedback” signal.
- Current mirror (Q_4 and Q_5 “program” the current, while Q_1 and Q_5 duplicate that current for active-loading of the differential pair as well as Q_6).
- Common-emitter amplification for high voltage gain (Q_6 with active loading).

¹⁴This term (topology) refers to the general *shape* or configuration of a circuit.

- Push-pull, common-collector amplification (power transistors Q_7 and Q_8).
- Class B/AB biasing (V_{bias} set to achieve desired hand-off between power transistors Q_7 and Q_8 during the zero-crossing portion of the AC signal).
- AC coupling of the input signal (through $C_{coupling}$) to eliminate any DC that might otherwise bias the differential pair stage.
- Negative feedback ($R_{feedback}$, R_4 , and $C_{feedback}$) works to re-inject a fraction of the load voltage back to the other input of the differential pair stage. This has the effect of reducing over-all voltage gain as well as (most importantly) stabilizing the amplifier's gain throughout a wide range of operating conditions including variations in DC supply voltage, changes in signal frequency, changes in device temperature, etc. Another benefit of this negative feedback is that it naturally forces the output to zero Volts when the audio input signal is zero Volts – in other words, the final transistors' bias automatically “centers” so that there should be negligible DC bias on the output signal driving the loudspeaker.
- Compensation capacitor ($C_{compensation}$) intentionally attenuates voltage gain at high frequencies to help prevent self-oscillation of the amplifier. This is another example of negative feedback in action, feeding part of Q_6 's collector signal to its base terminal in order to intentionally degrade the voltage gain of that stage.
- Split DC power supply (while not strictly an amplifier concept, this form of power supply allows push-pull driving of loudspeaker current while maintaining DC coupling to that load).

As mentioned, this schematic is *simplified* from how a real manufactured audio power amplifier might be designed. If you examine a professional-grade audio power amplifier circuit you will likely find additions such as:

- Interesting networks of diodes, transistors, and/or resistors designed to provide the V_{bias} class B/AB biasing summarized by V_{bias} in the simplified schematic
- Paired transistors (either Darlington or Sziklai pairs) for increased current gain in any of the stages
- Paralleled power transistors in the final stage for greater current capacity
- Emitter resistors on the power transistors to help stabilize DC biasing for more reliable class B/AB operation
- Active loading on top *and* bottom of differential pair stage transistors
- Decoupling capacitors on the DC power supply rails to stabilize those voltages
- Series inductor on the output terminal to improve stability when driving some types of loudspeaker with capacitive crossover (filter) networks
- Fuses on the power supply rails (and perhaps on the output terminal too) for overcurrent protection
- More stages for finer control of voltage amplification

- Alternative-design current regulator networks (other than simple current mirrors)
- Integrated-circuit (IC) differential and/or voltage gain stages, rather than building each and every stage using discrete transistors
- MOSFET power transistors instead of BJT, with appropriate biasing networks
- Thermally-controlled power transistor biasing to decrease conduction angle (i.e. amount of time spent “on”) as the transistors become hot
- AC rather than DC coupling between stages

Chapter 4

Animations

Some concepts are much easier to grasp when seen in *action*. A simple yet effective form of animation suitable to an electronic document such as this is a “flip-book” animation where a set of pages in the document show successive frames of a simple animation. Such “flip-book” animations are designed to be viewed by paging forward (and/or back) with the document-reading software application, watching it frame-by-frame. Unlike video which may be difficult to pause at certain moments, “flip-book” animations lend themselves very well to individual frame viewing.

4.1 Animation of an NPN BJT turning on

Bipolar junction transistors are naturally “off” devices, having no continuous channel of conductive semiconductor material joining emitter and collector terminals. Instead the NPN or PNP sandwich interrupts that path with two series-opposed PN junctions. However, when the base-emitter PN junction is forward-biased by an external source, majority charge carriers from the emitter region are drawn into the thin and lightly-doped base region where some of them travel out the base but most carry past into the depletion region of the base-collector PN junction to be swept into the collector region. For an NPN transistor this means electrons from the N-type emitter region will be injected into the P-type base region (as “minority” type carriers there) before most of them get swept into the N-type collector region.

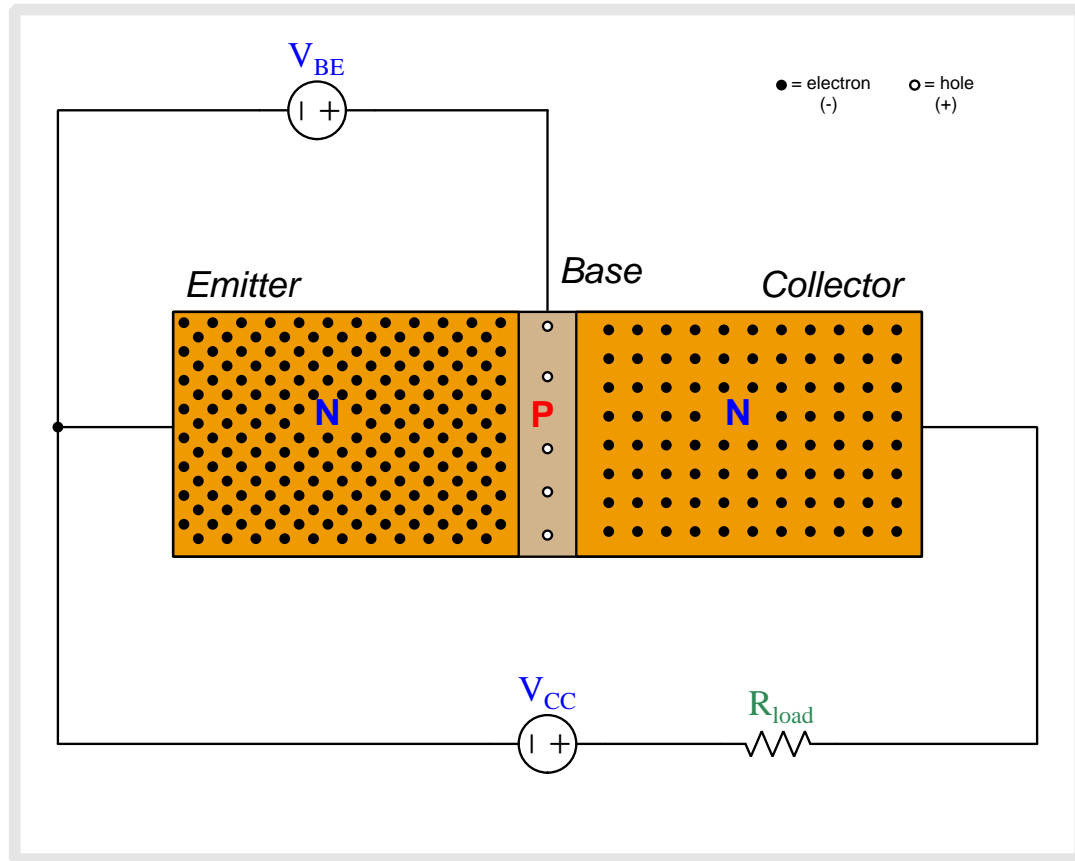

Above we see an NPN bipolar junction transistor connected to two sources. V_{BE} applies a controlling voltage between the base and emitter. V_{CC} is the voltage source which will drive current through the load resistor once the transistor begins to conduct.

The N-doped emitter region is heavily doped and therefore contains many free electrons (negatively-charged) as mobile charge carriers. The collector region is also doped as an N-type semiconductor but the dopant concentration is less than that of the emitter. The P-doped base region is the least-doped of them all with just a few holes (positively-charged) as mobile charge carriers. Note that when load current begins to flow, its direction will be shown in *conventional flow notation* which is the same direction in which holes move but is opposite to the direction free electrons move.

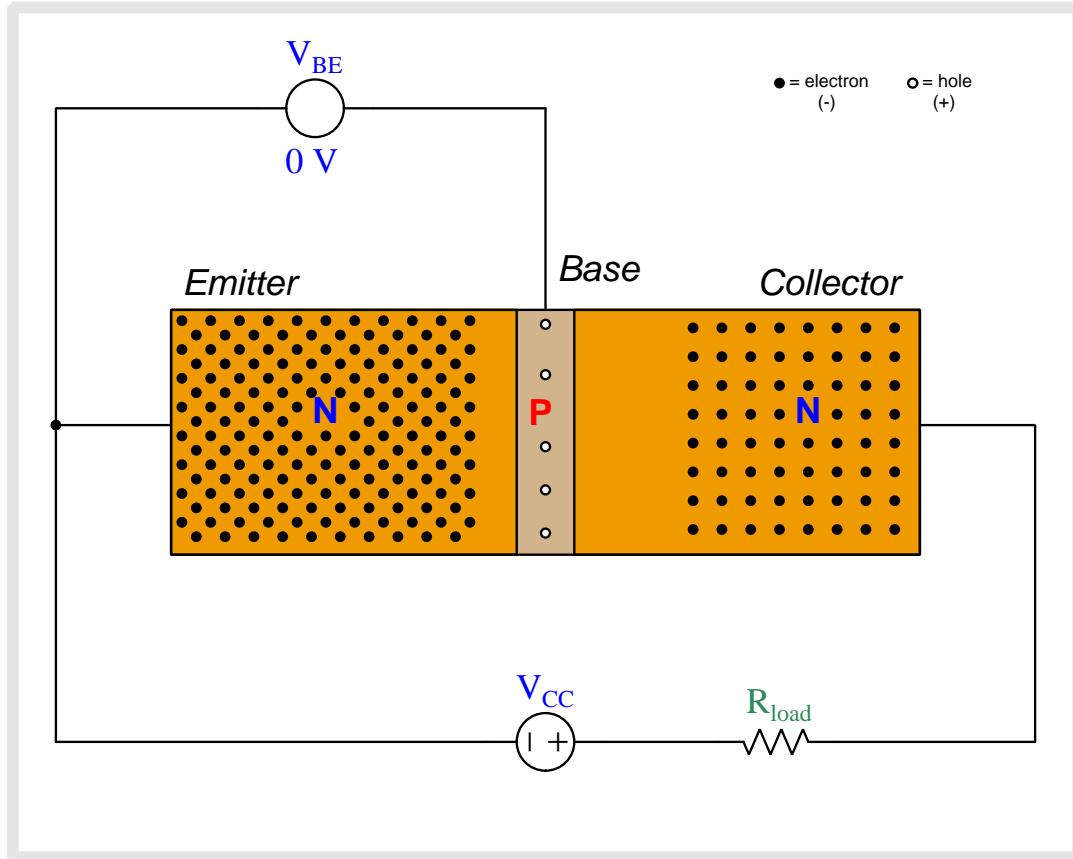

Note the depletion regions shown as areas with no free charge carriers, the base-collector depletion region being wider than the base-emitter depletion region due to the applied reverse-bias potential of V_{CC} .

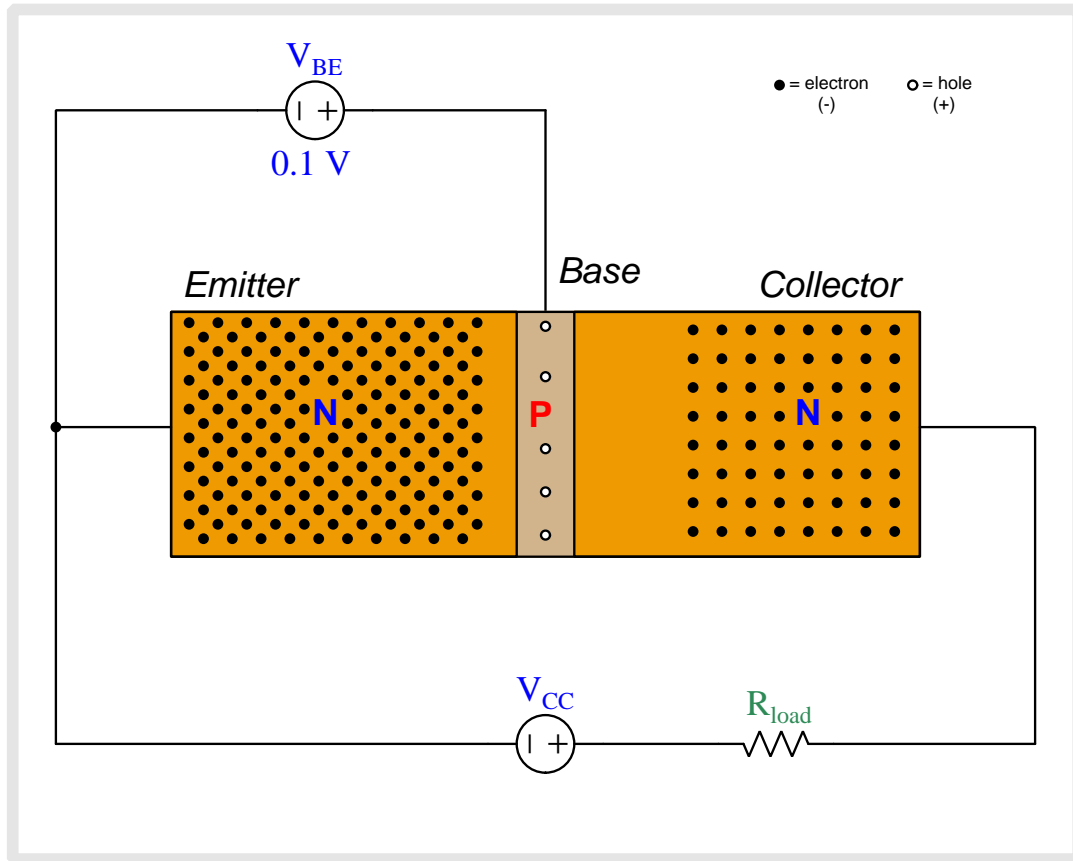

As we begin to apply a base-to-emitter voltage with the base positive and emitter negative, that applied potential difference drives the emitter and base regions' respective charge carriers toward each other, collapsing the base-emitter depletion region.

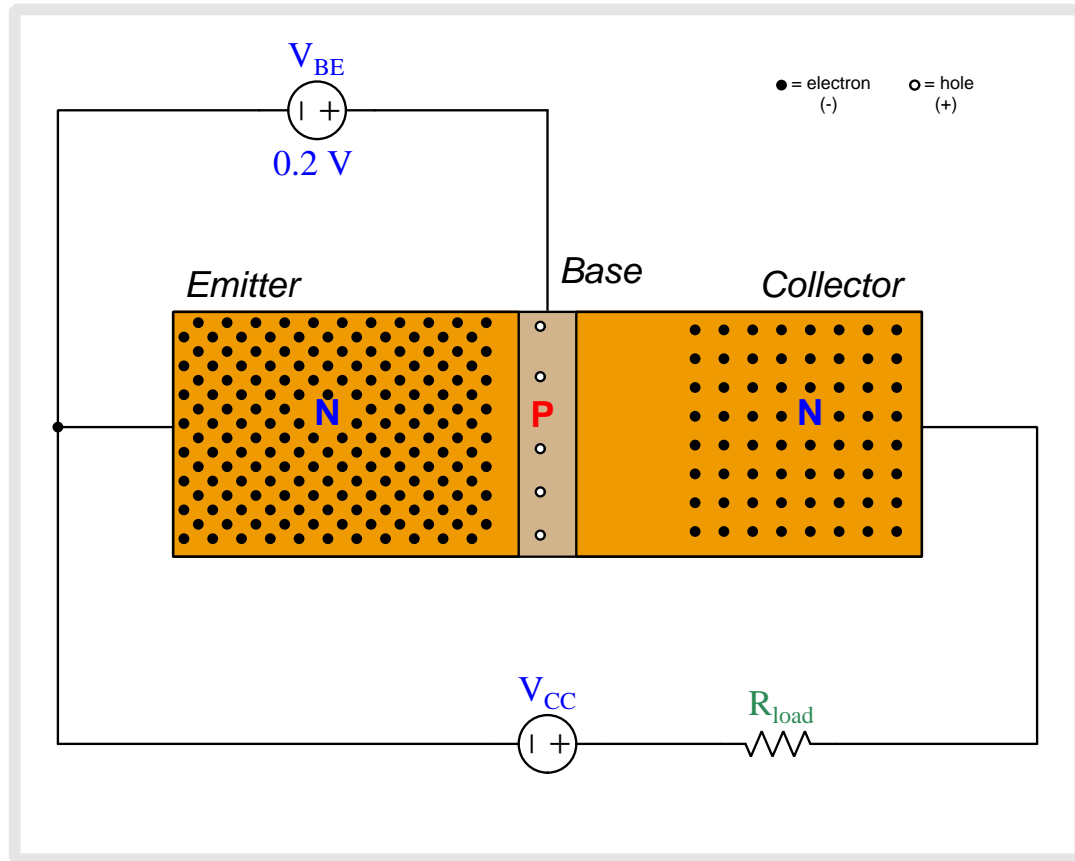

As we begin to apply a base-to-emitter voltage with the base positive and emitter negative, that applied potential difference drives the emitter and base regions' respective charge carriers toward each other, collapsing the base-emitter depletion region.

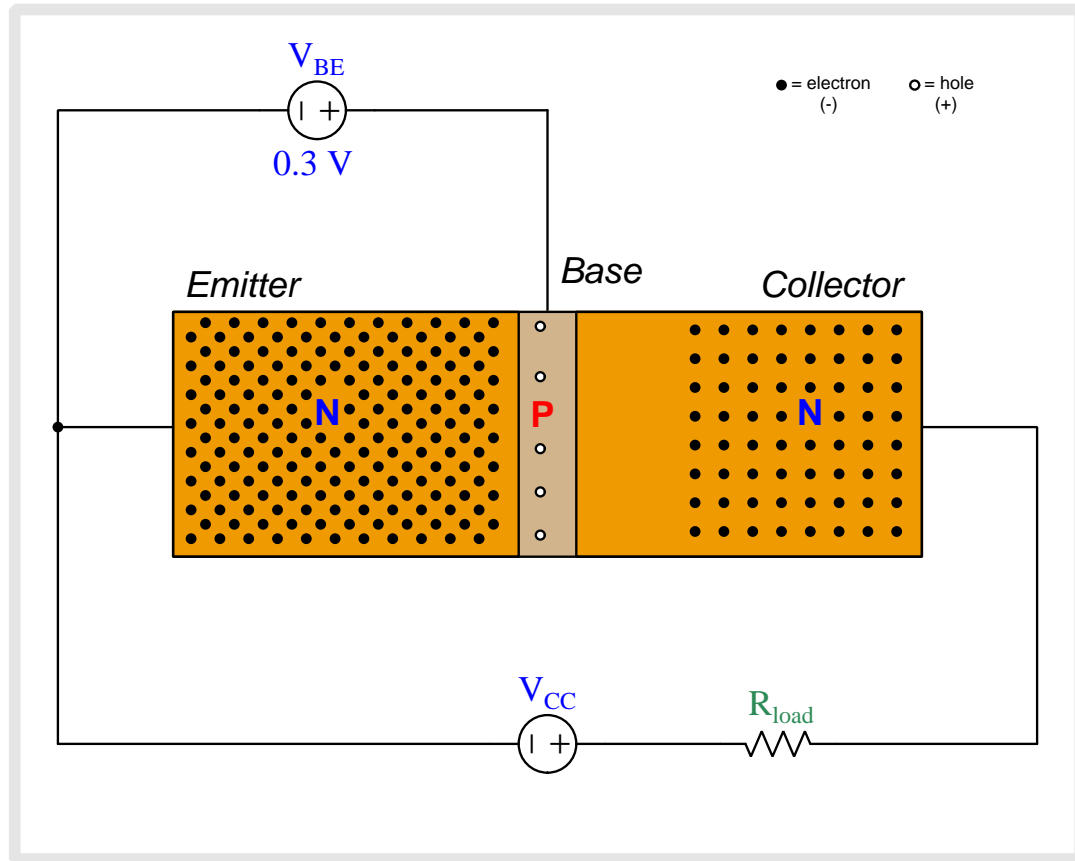

As we begin to apply a base-to-emitter voltage with the base positive and emitter negative, that applied potential difference drives the emitter and base regions' respective charge carriers toward each other, collapsing the base-emitter depletion region.

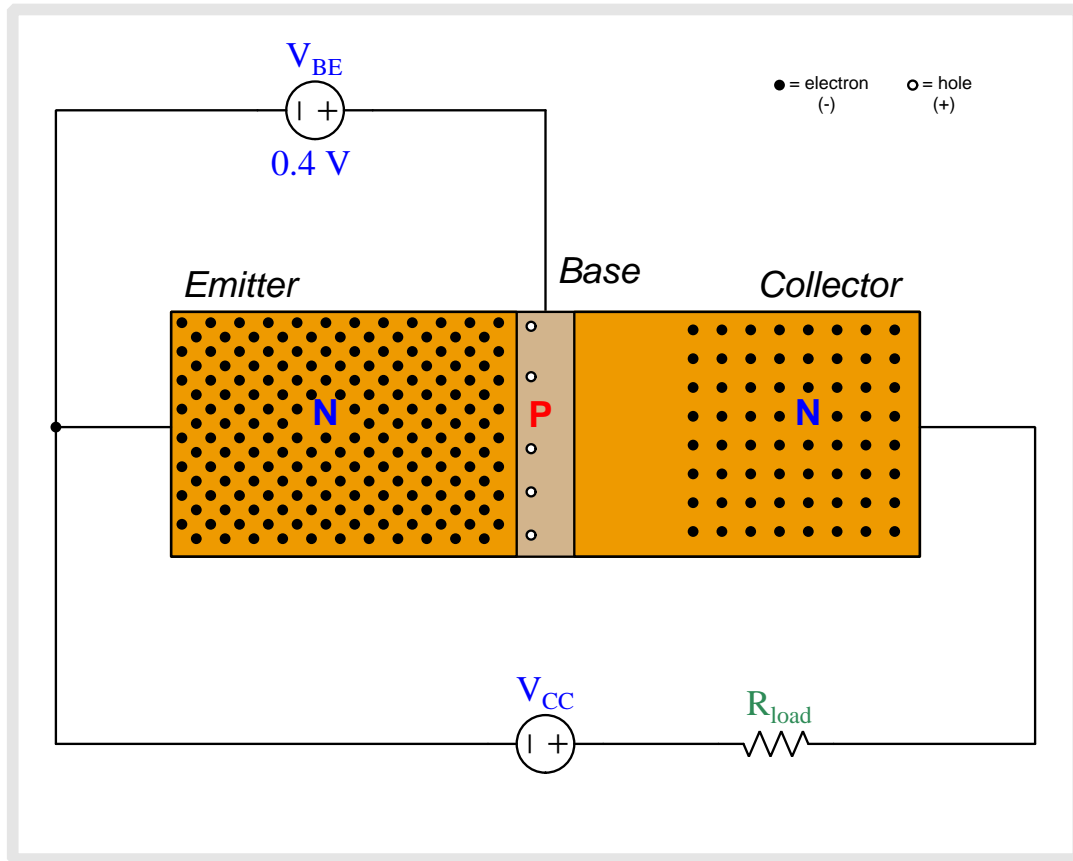

As we begin to apply a base-to-emitter voltage with the base positive and emitter negative, that applied potential difference drives the emitter and base regions' respective charge carriers toward each other, collapsing the base-emitter depletion region.

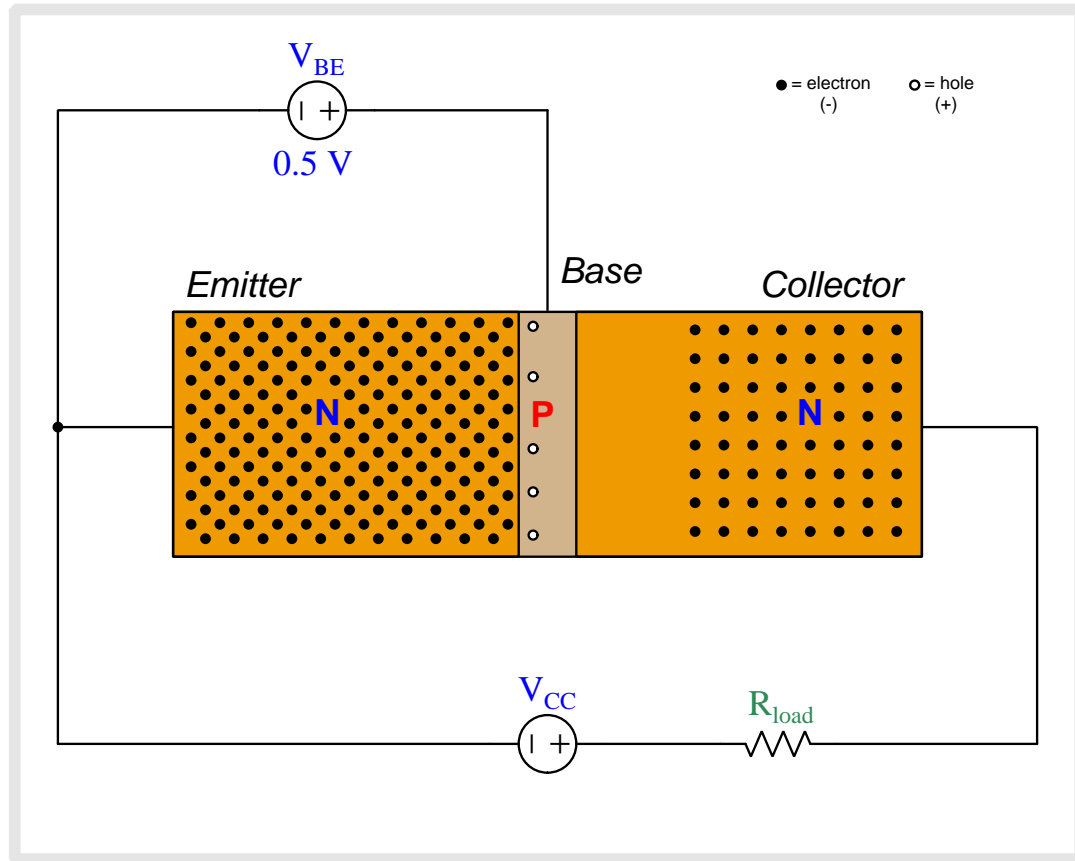

As we begin to apply a base-to-emitter voltage with the base positive and emitter negative, that applied potential difference drives the emitter and base regions' respective charge carriers toward each other, collapsing the base-emitter depletion region.

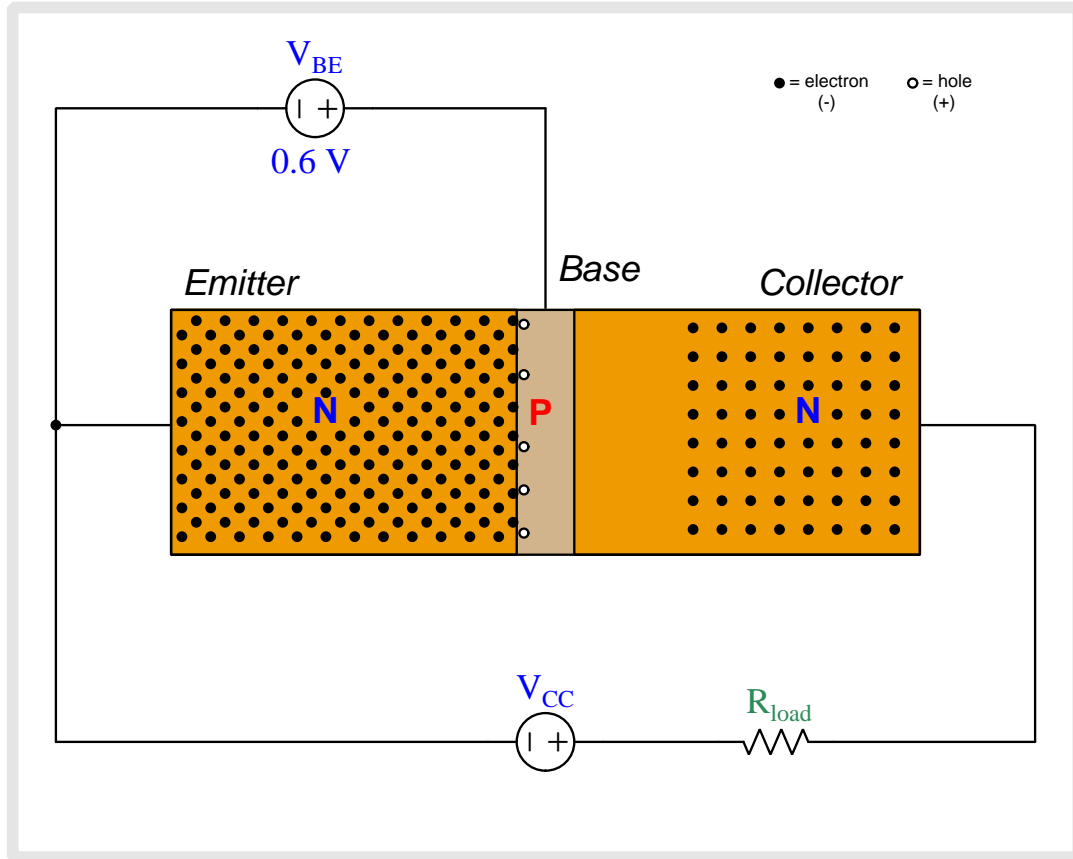

As we begin to apply a base-to-emitter voltage with the base positive and emitter negative, that applied potential difference drives the emitter and base regions' respective charge carriers toward each other, collapsing the base-emitter depletion region.

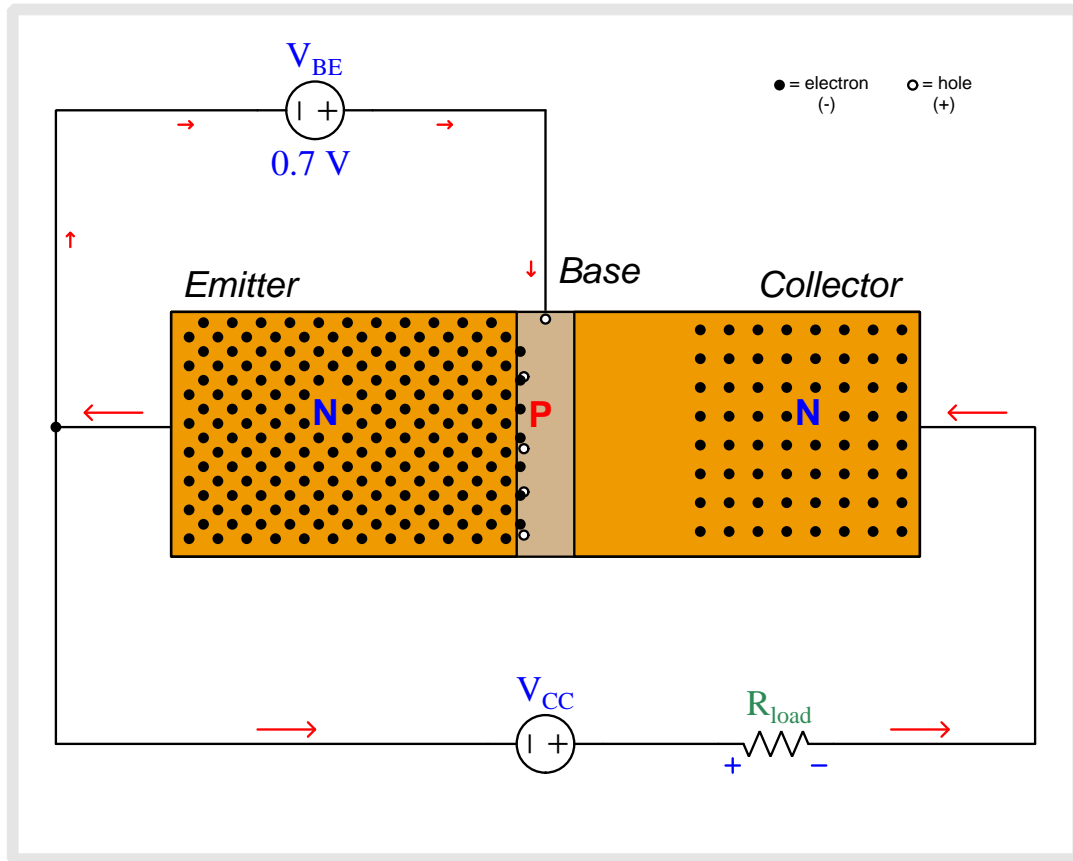

Now there is enough base-to-emitter voltage to fully collapse the base-emitter depletion region which allows base current to flow through the V_{BE} source. New holes enter into the base region from the base terminal to replenish any holes that have combined with electrons from the emitter region. Most of the emitter-injected electrons do *not* combine with holes, though, because the lightly-doped base region provides few holes to combine with. Therefore, most of the electrons injected into the base region from the emitter region begin to drift toward the collector.

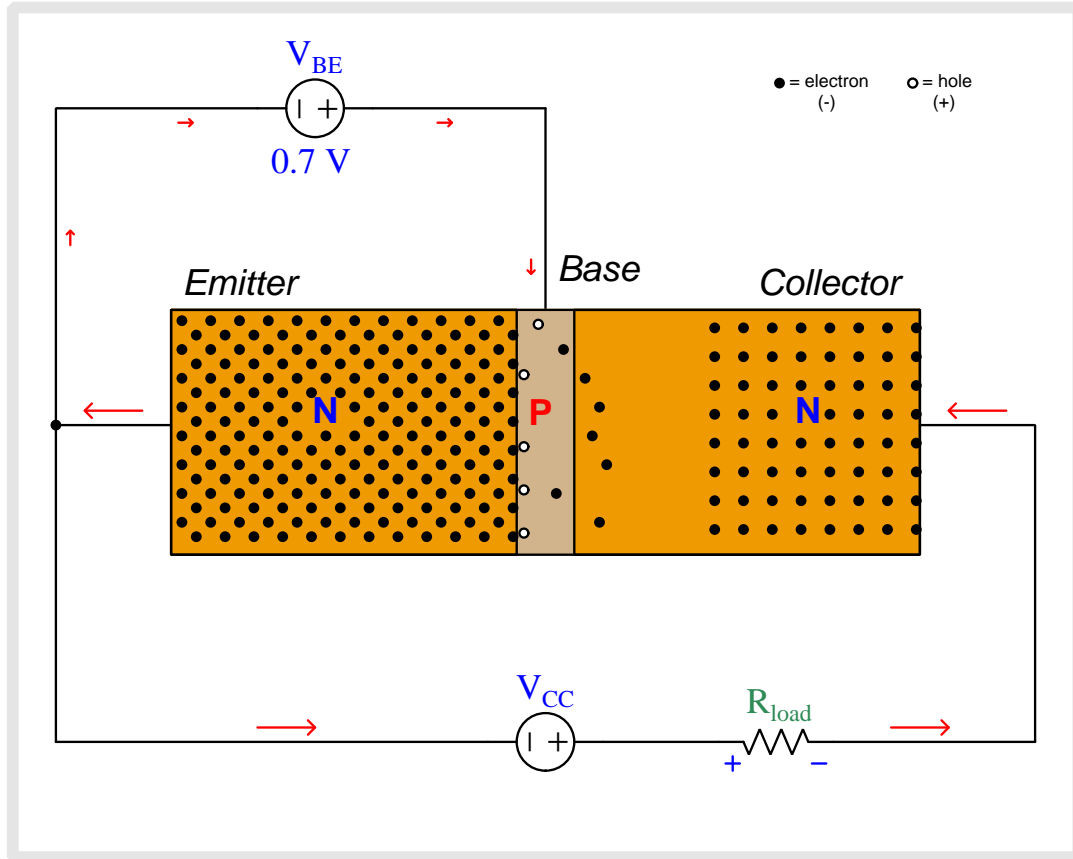

The electric field imposed by V_{CC} across the base-collector PN junction quickly “sweeps” electrons toward the collector terminal, constituting current through the load resistor.

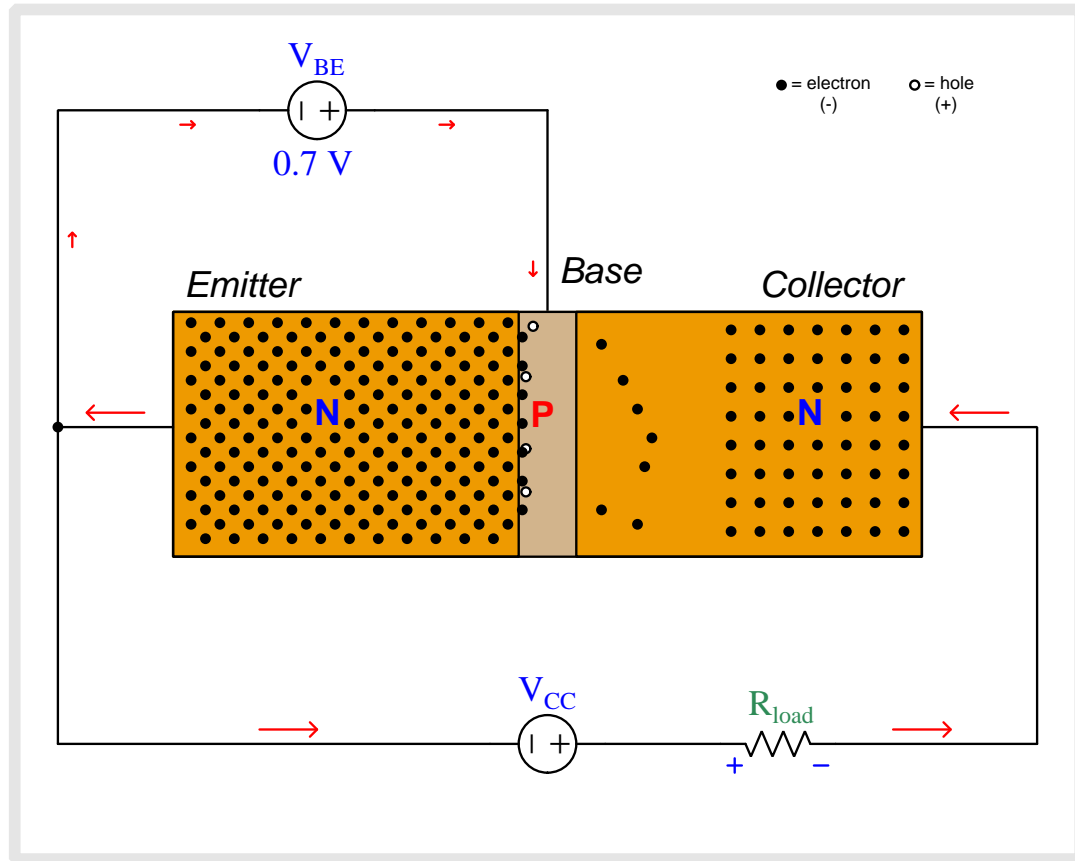

The electric field imposed by V_{CC} across the base-collector PN junction quickly “sweeps” electrons toward the collector terminal, constituting current through the load resistor.

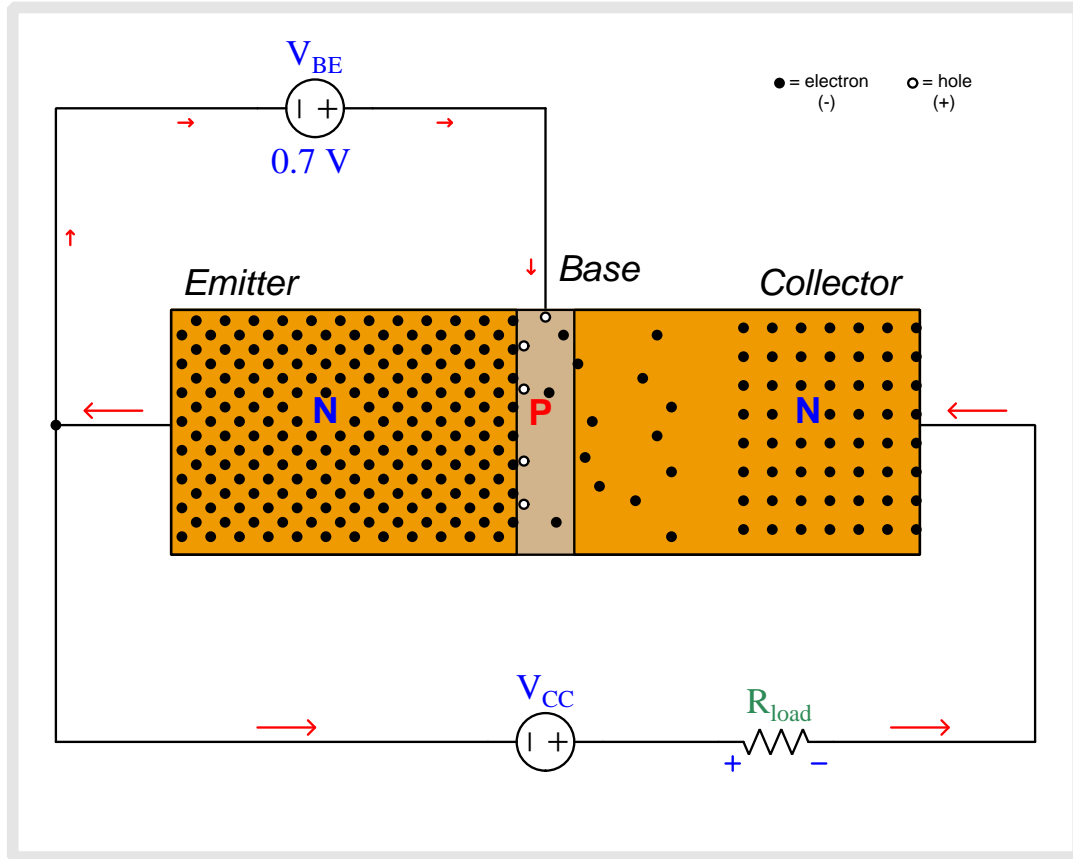

The electric field imposed by V_{CC} across the base-collector PN junction quickly “sweeps” electrons toward the collector terminal, constituting current through the load resistor.

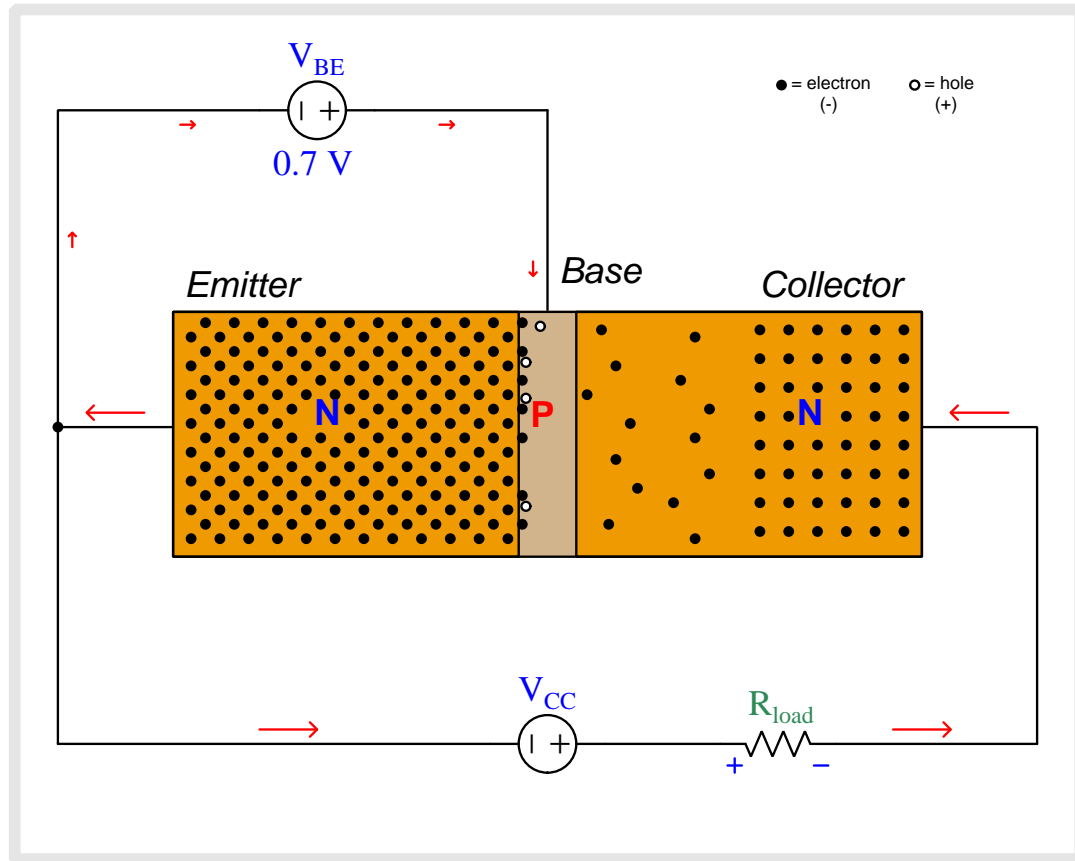

The electric field imposed by V_{CC} across the base-collector PN junction quickly “sweeps” electrons toward the collector terminal, constituting current through the load resistor.

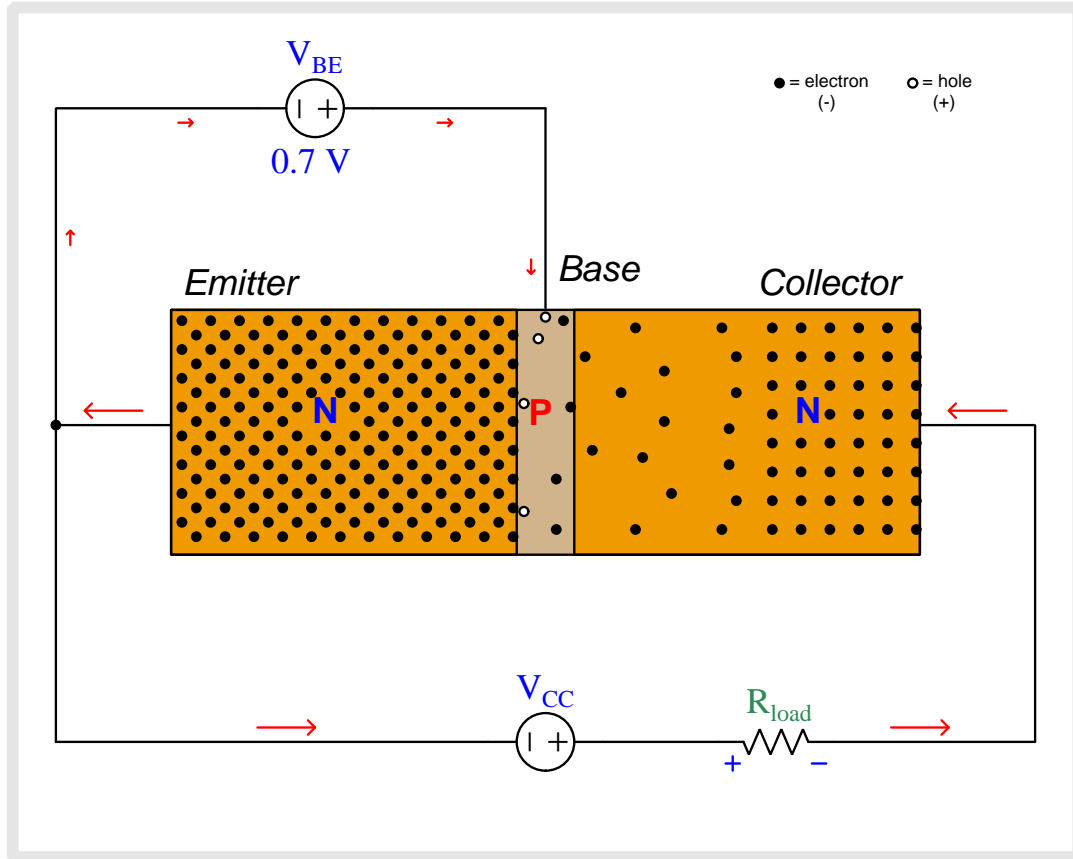

The electric field imposed by V_{CC} across the base-collector PN junction quickly “sweeps” electrons toward the collector terminal, constituting current through the load resistor.

4.2 Animation of class-B crossover distortion

The following animation shows an *improperly-biased* push-pull amplifier exhibiting crossover distortion. Ideally, the two transistors should “hand off” to one another seamlessly as the signal passes through zero, but as a result of improper biasing there is a substantial period of time at each zero-crossing point where both transistors remain off, neither sourcing nor sinking load current.

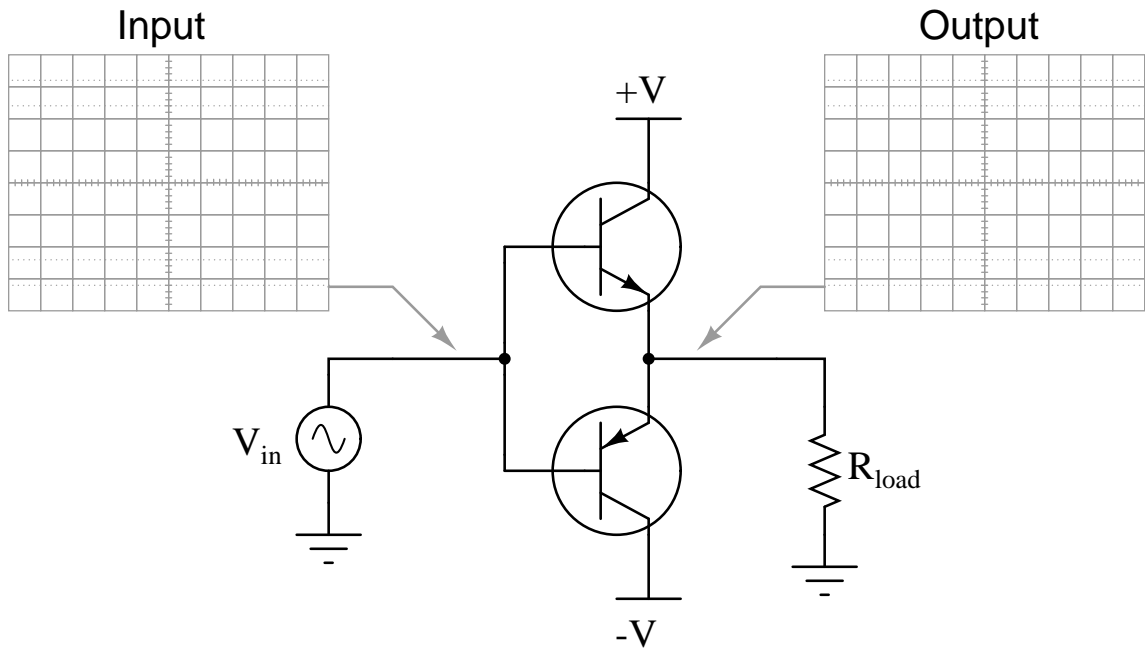

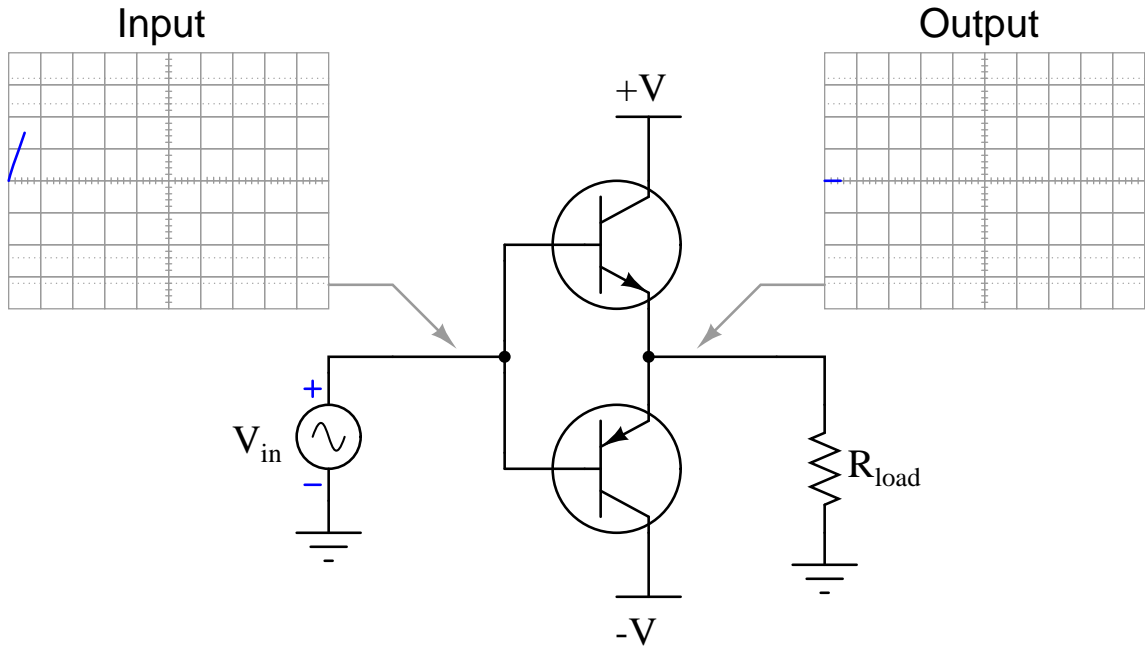

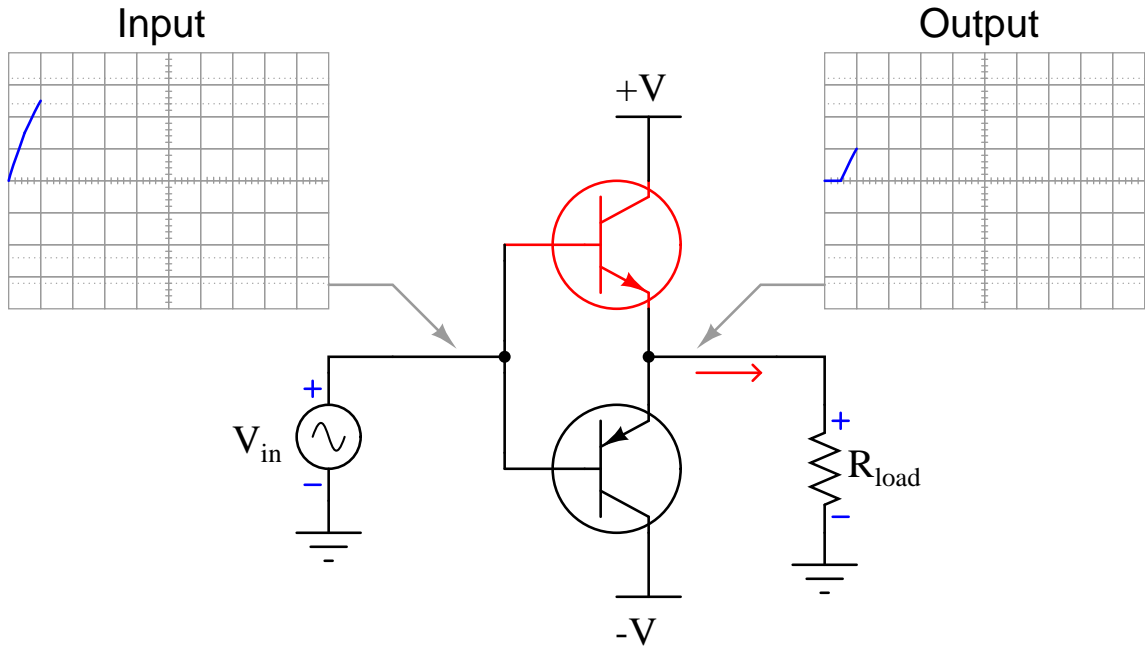

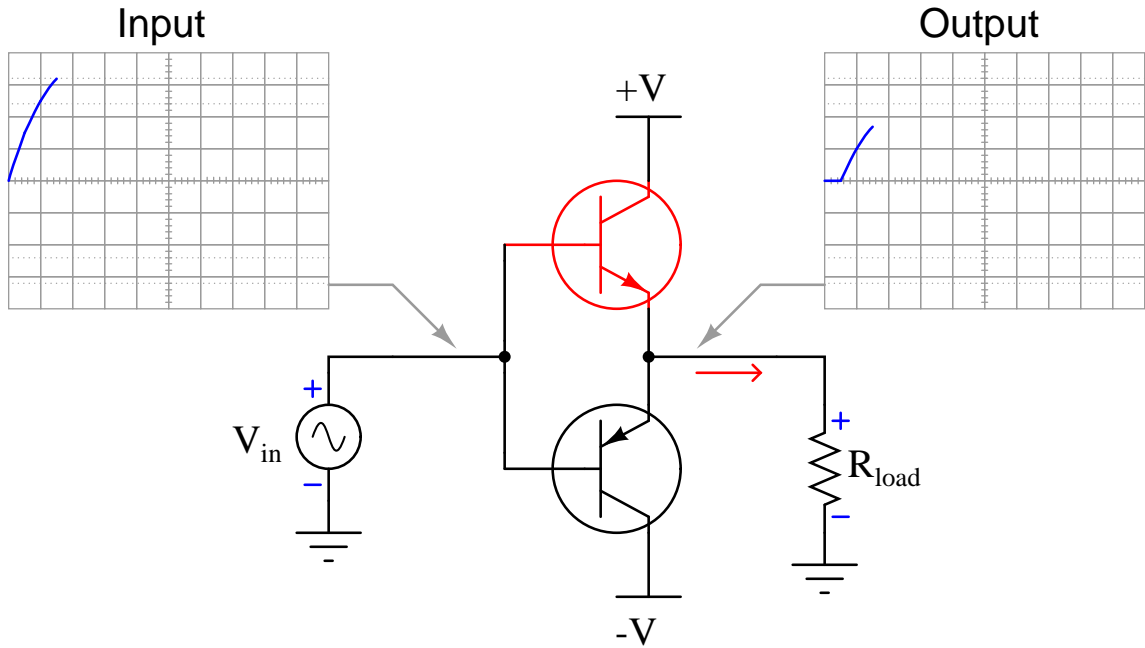

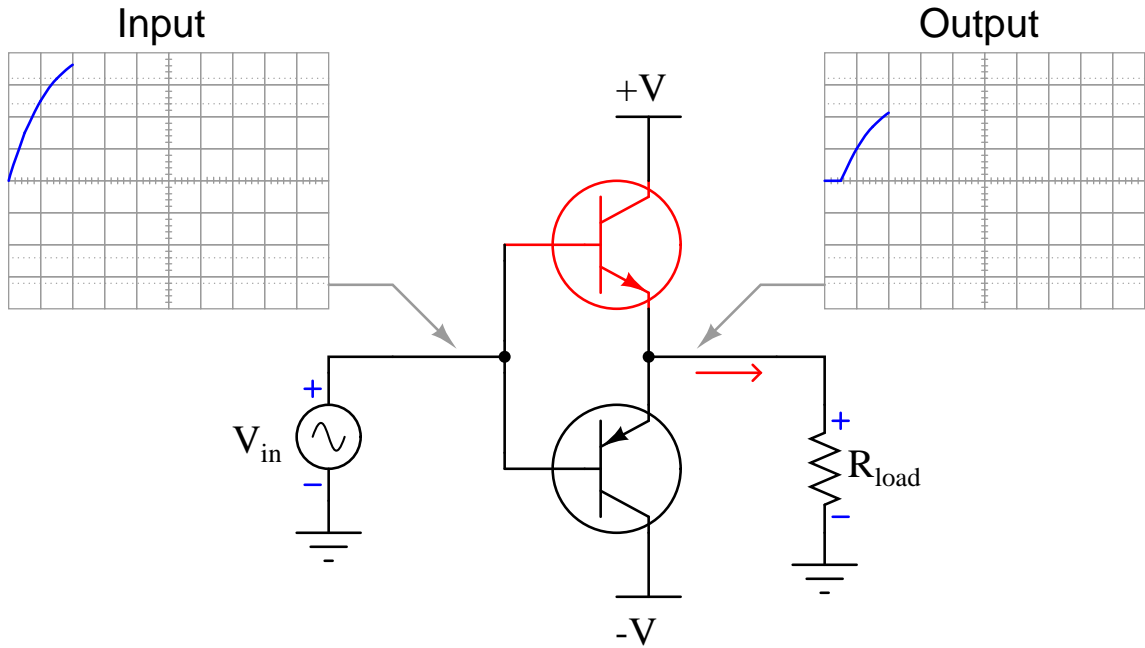

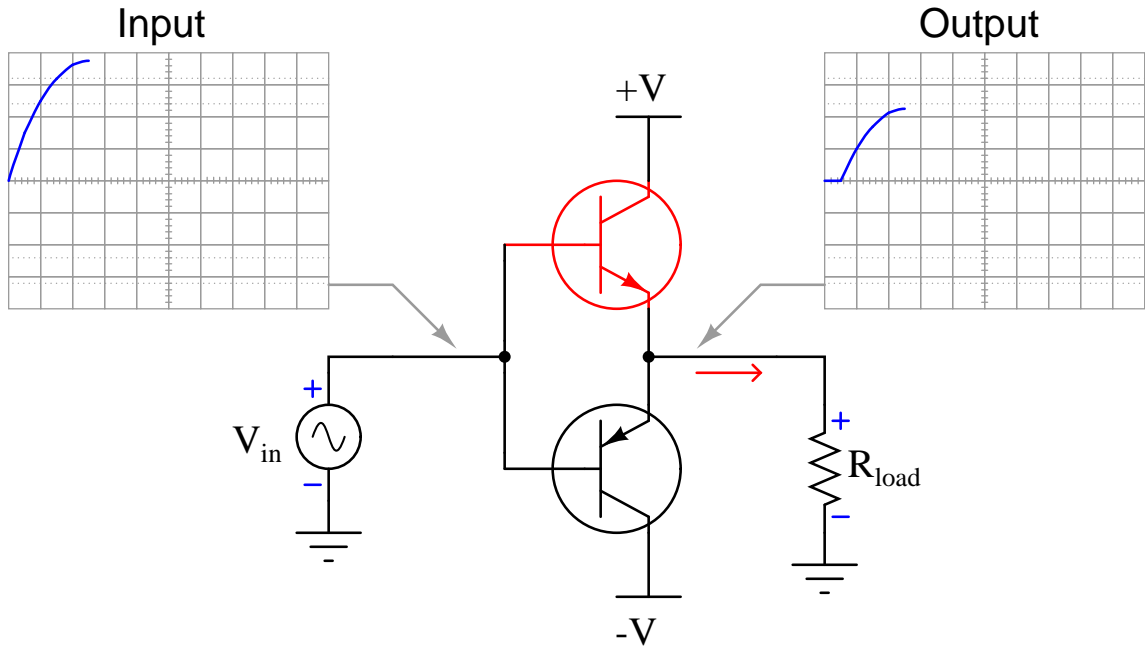

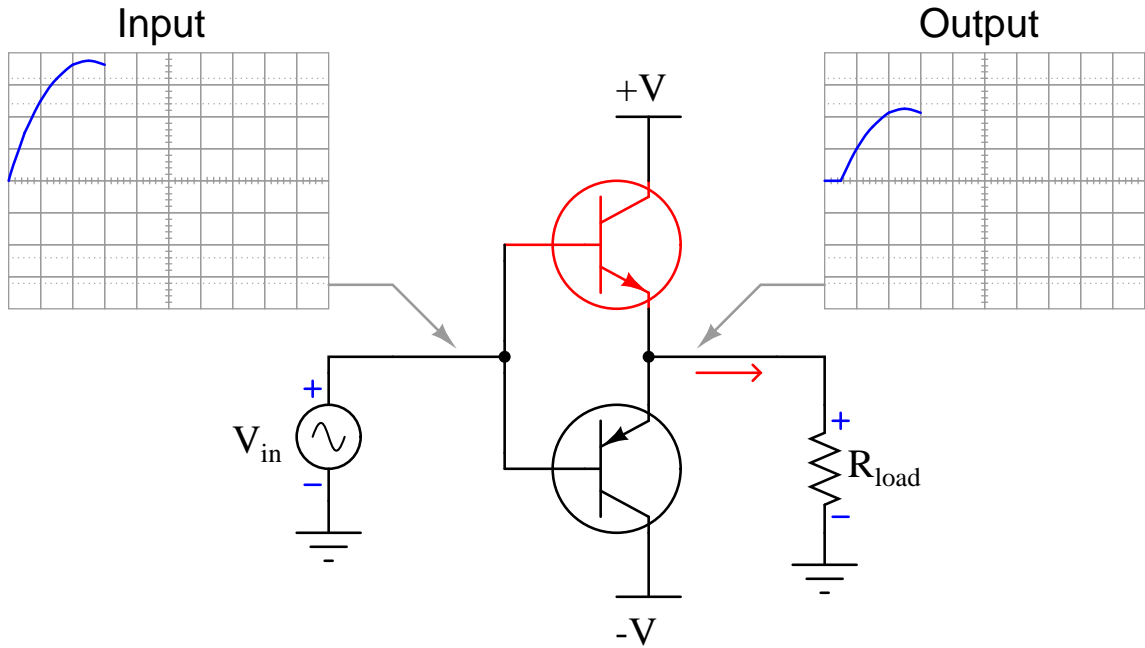

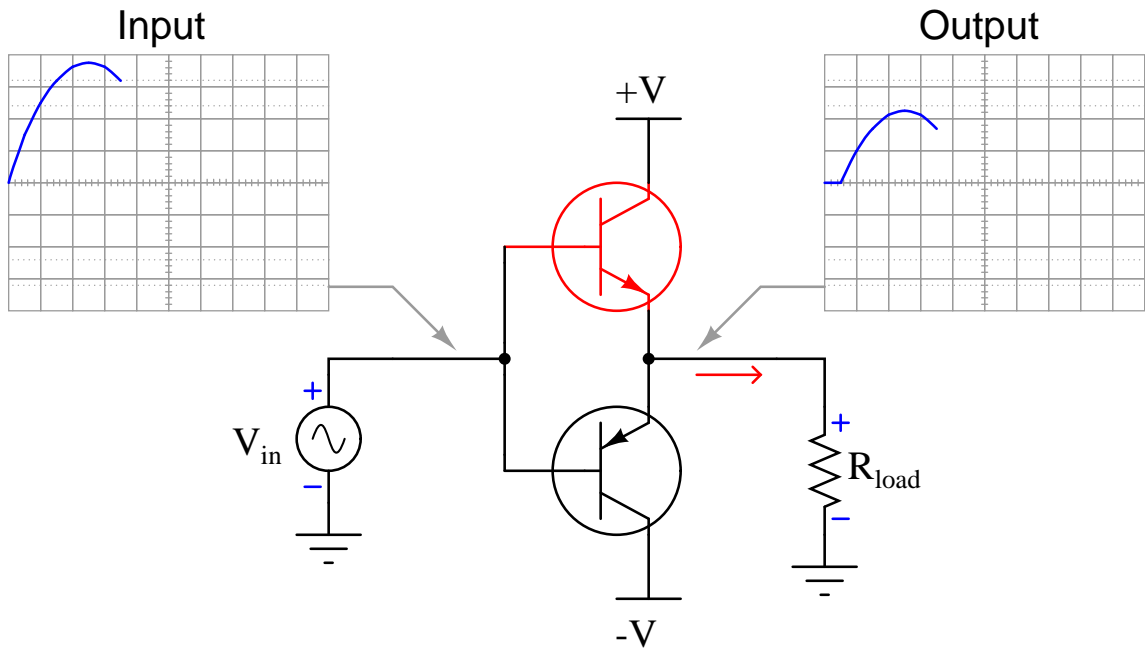

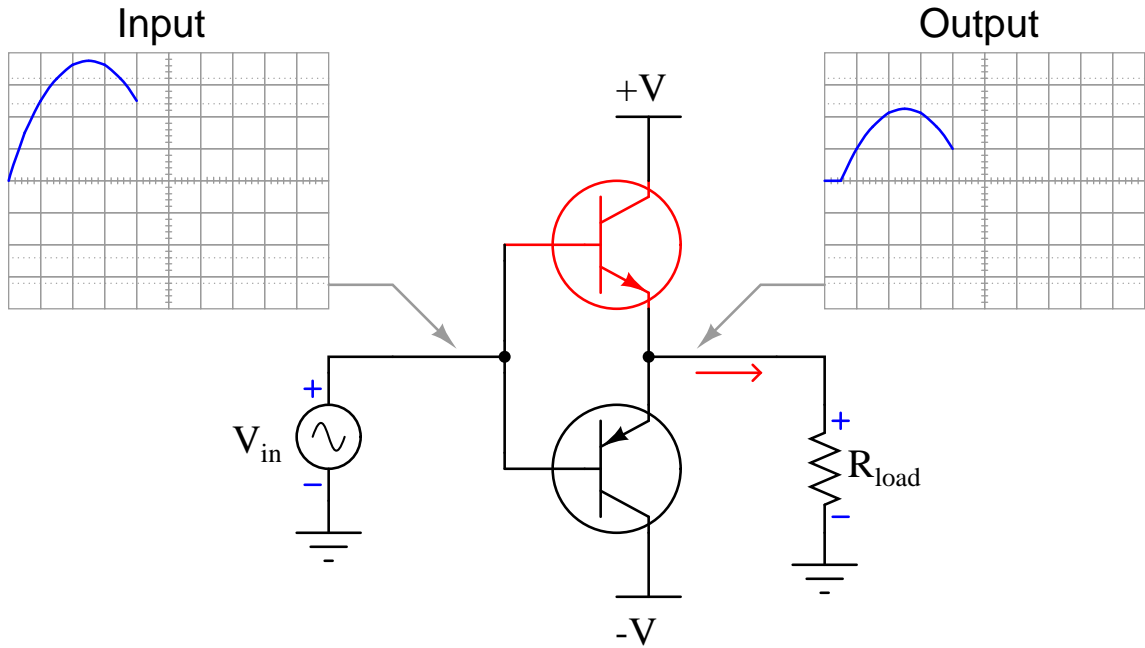

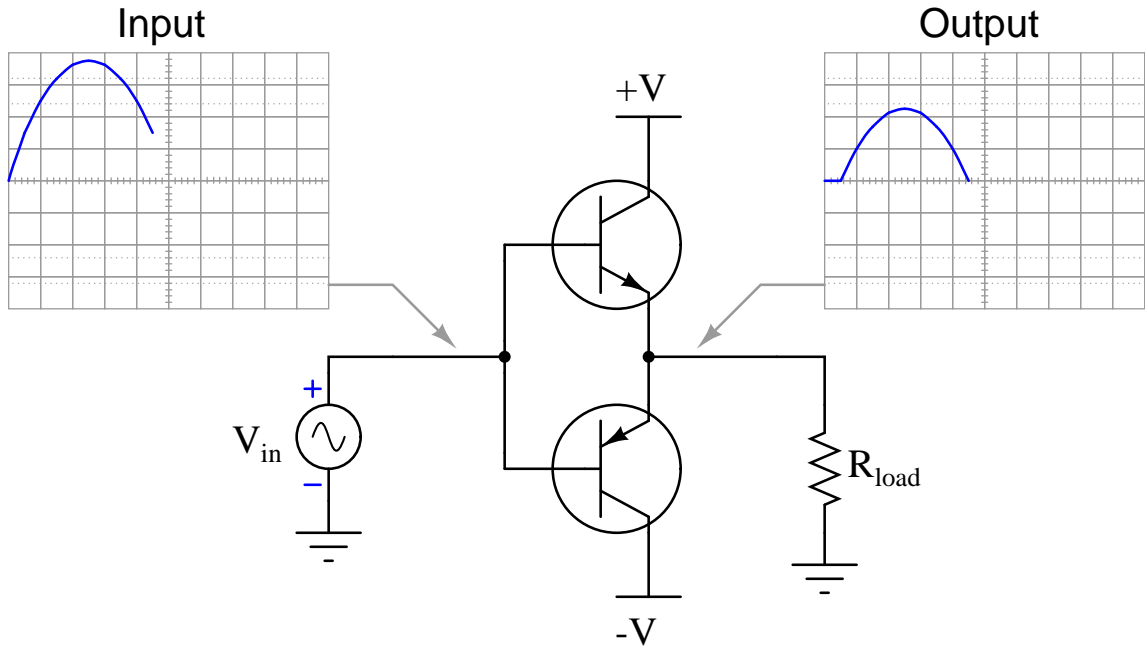

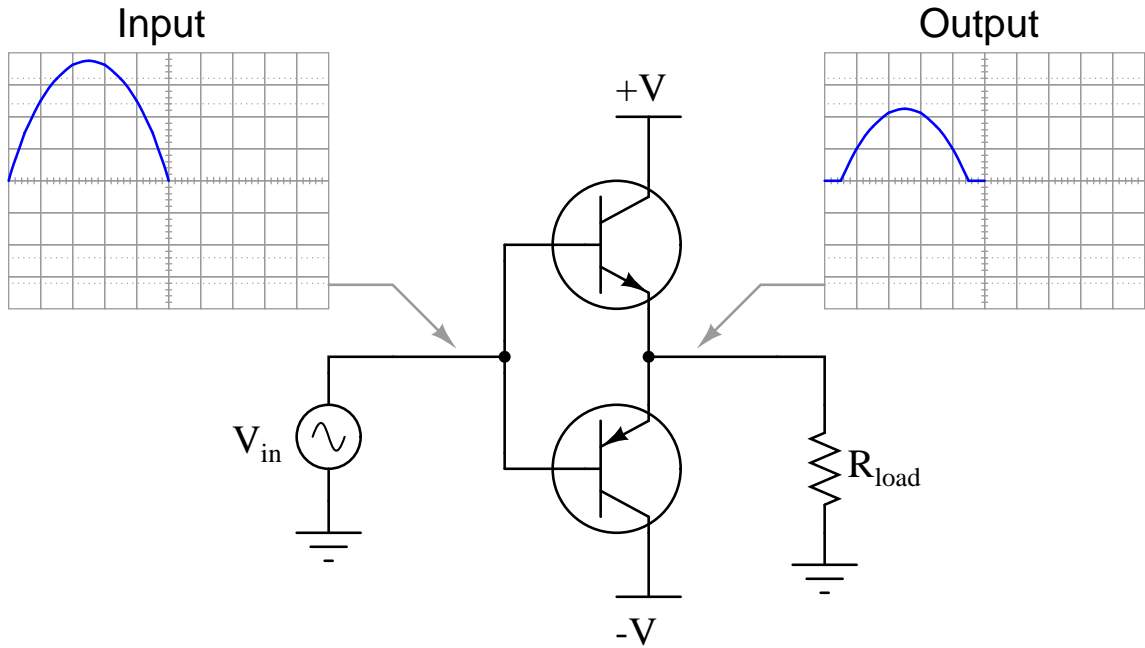

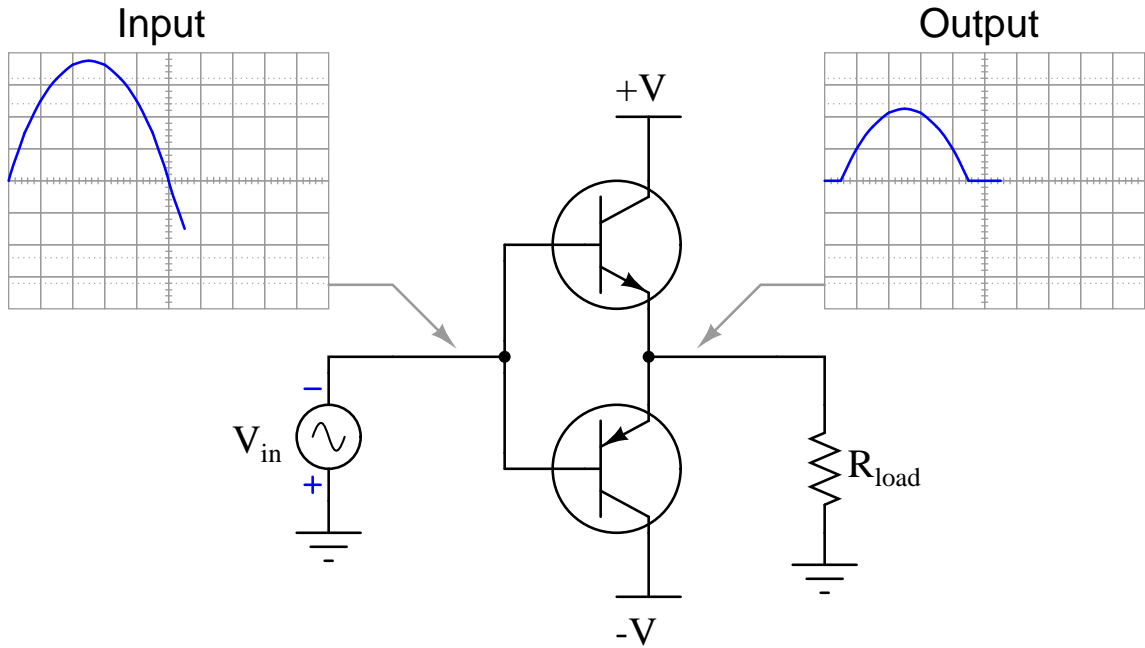

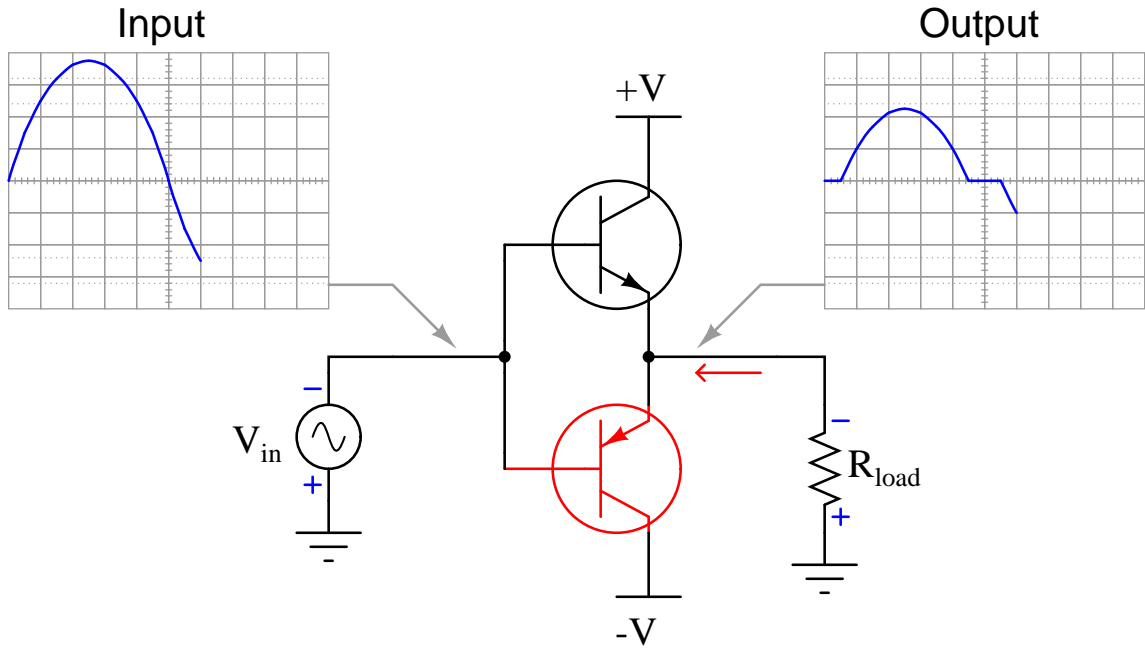

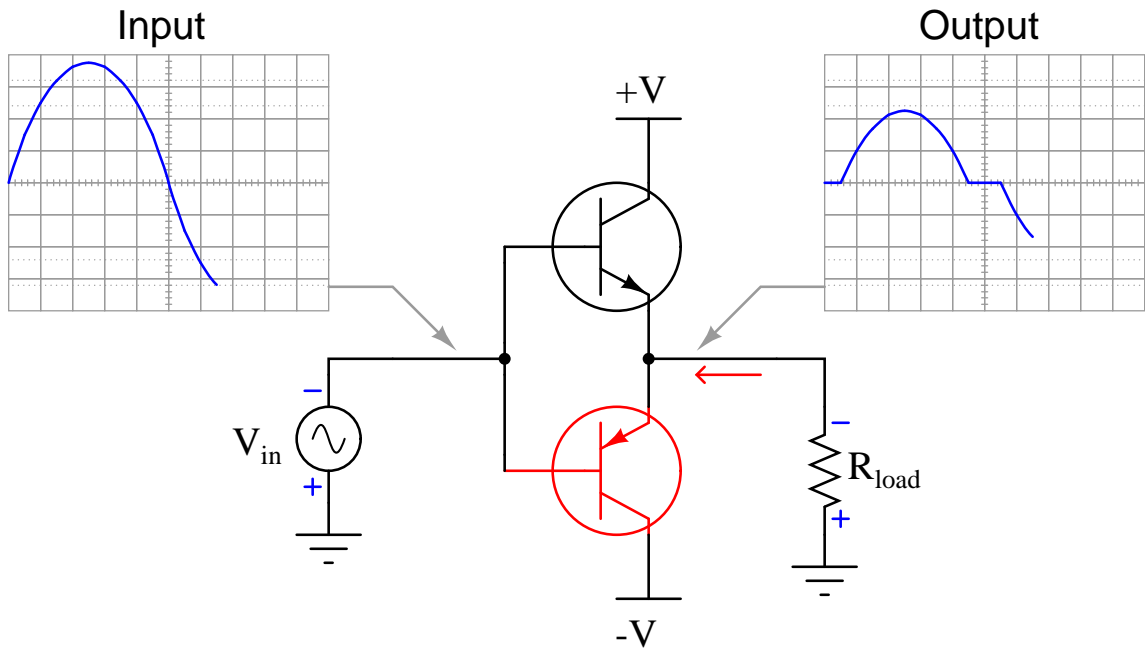

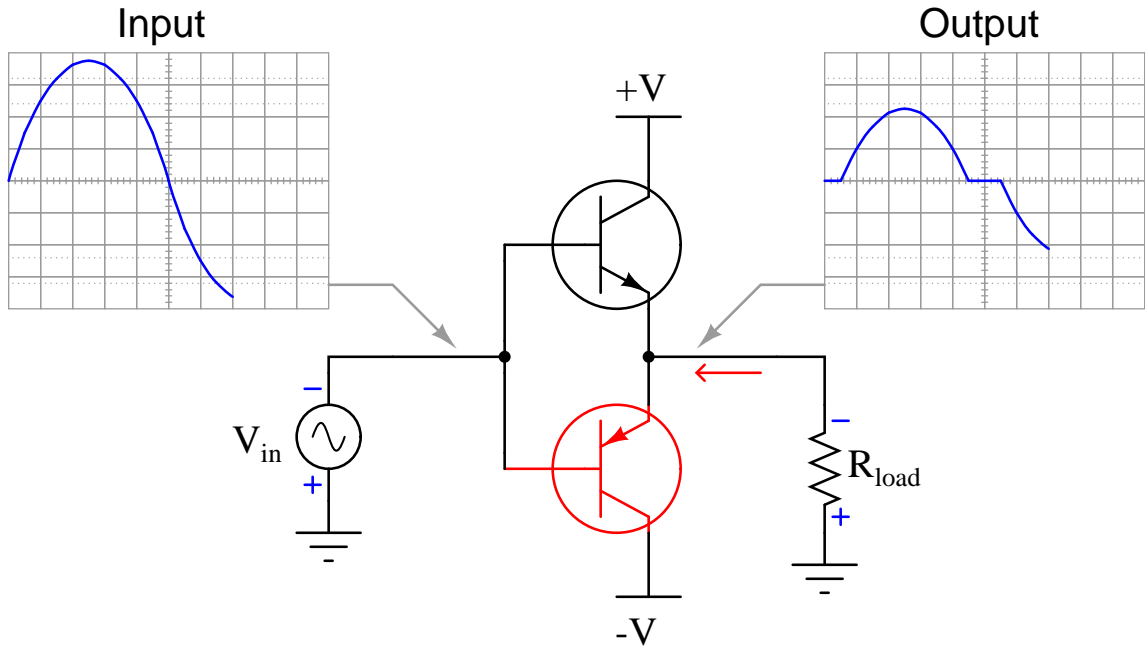

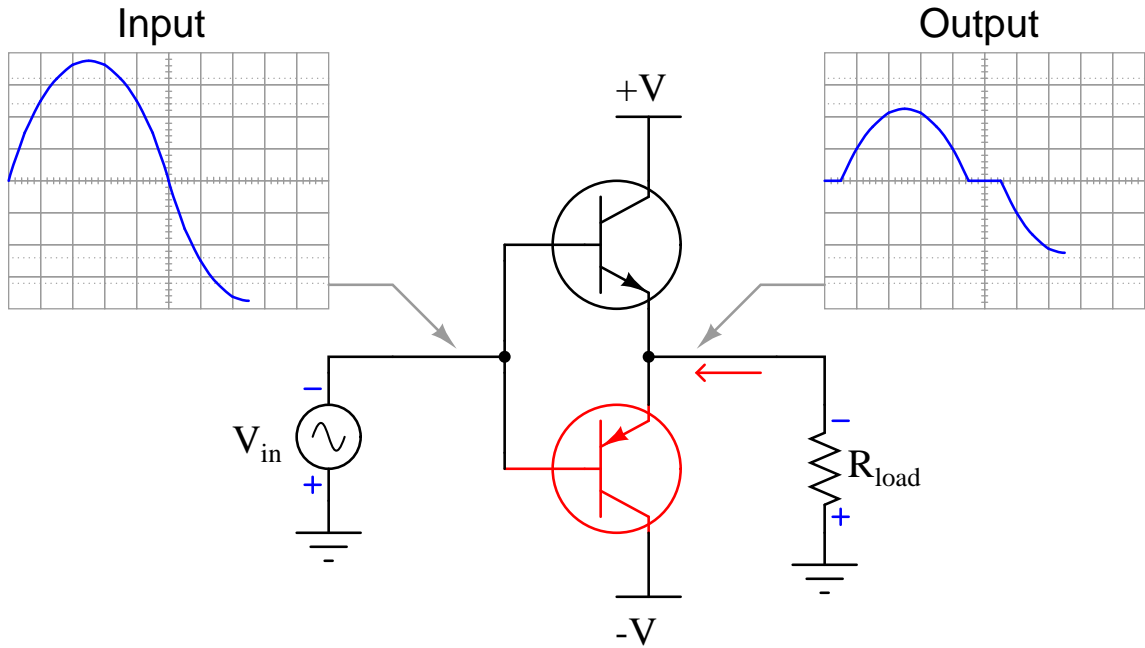

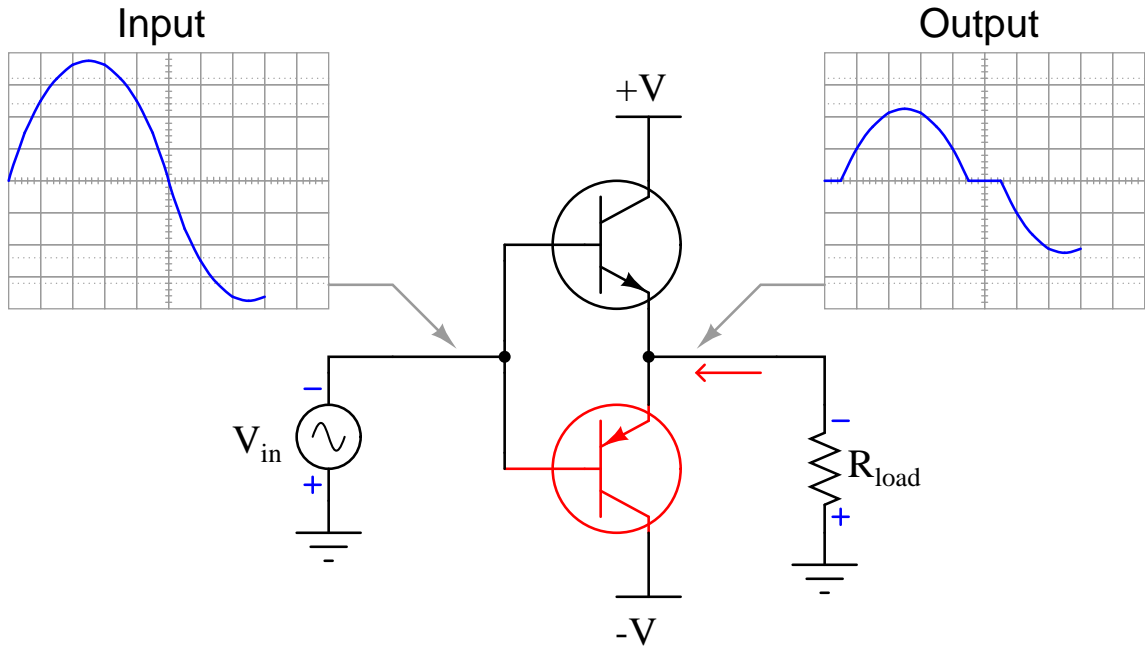

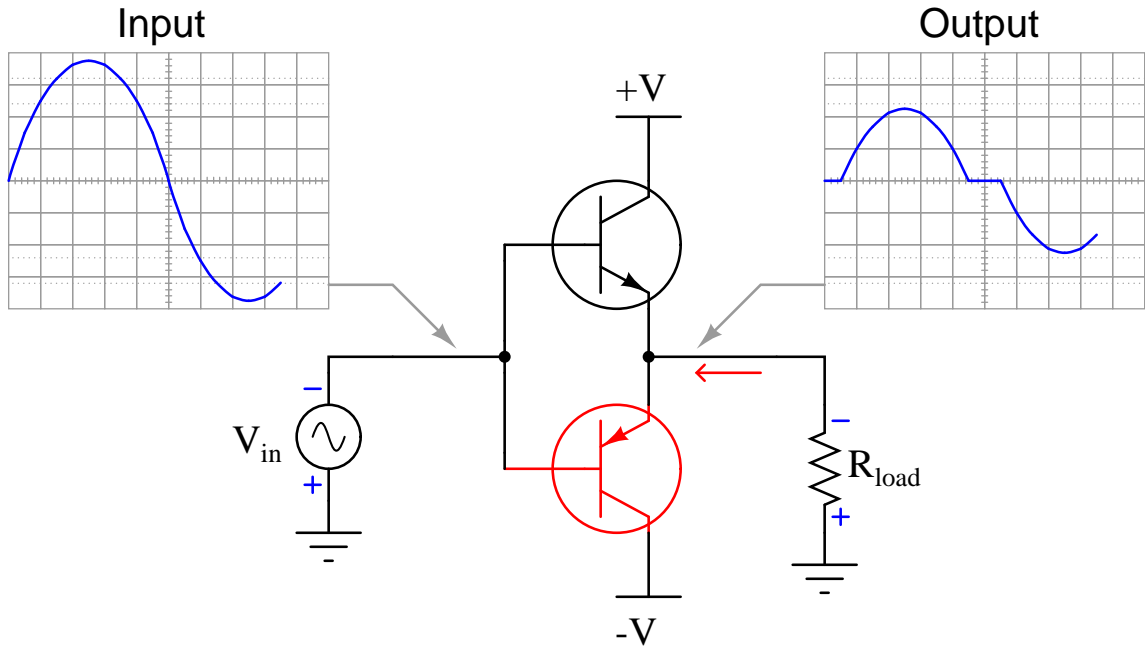

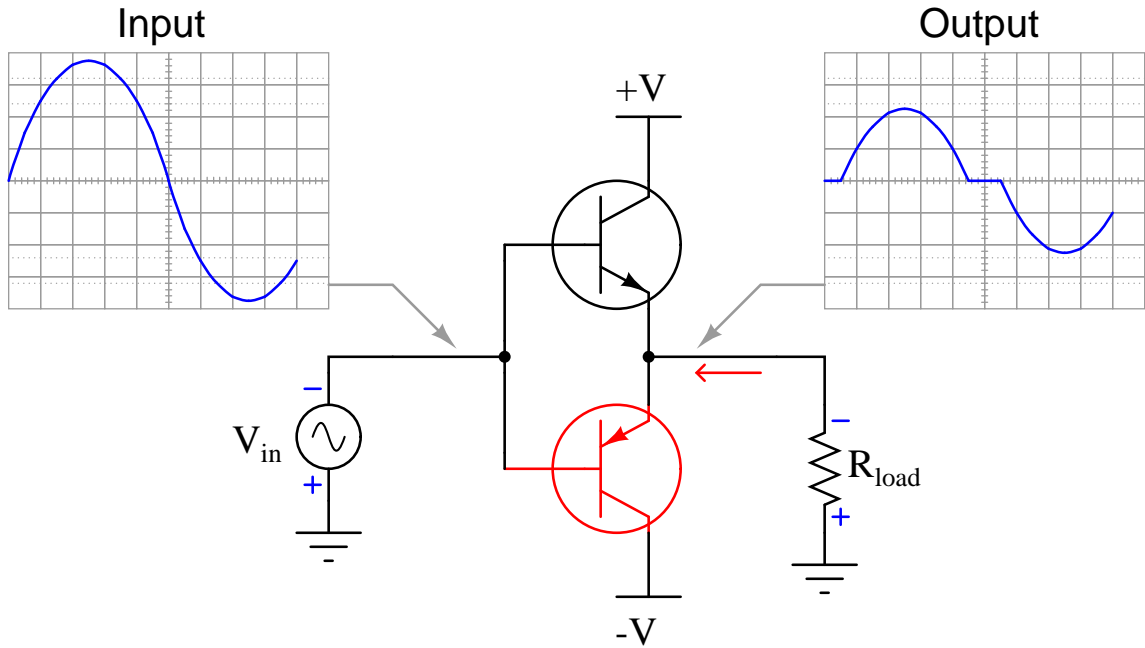

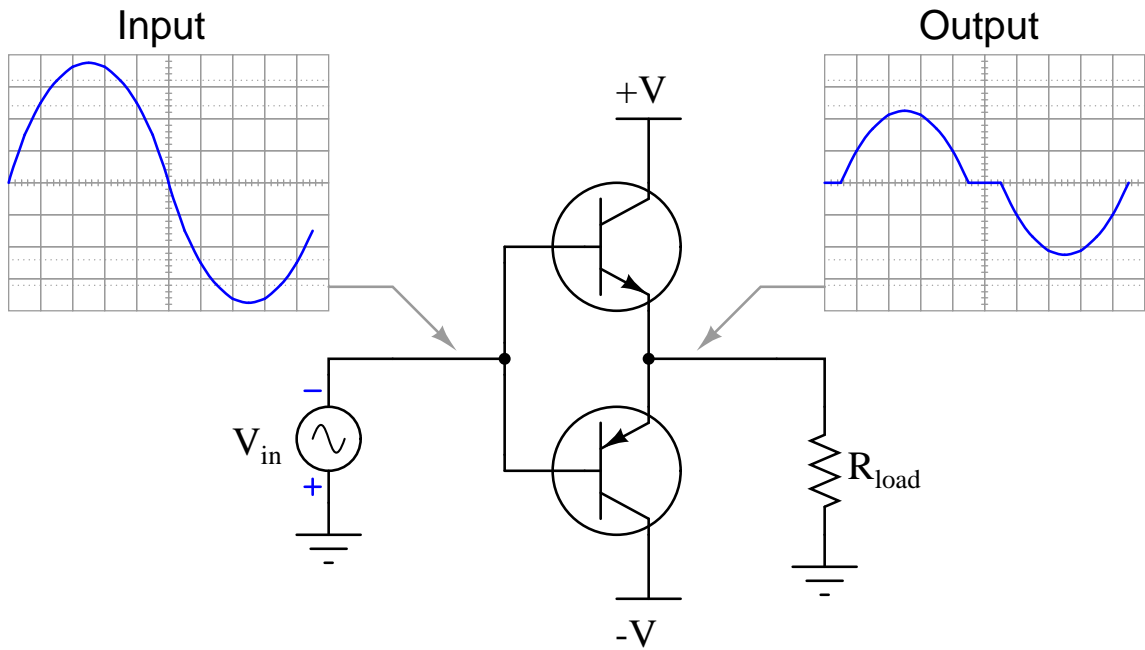

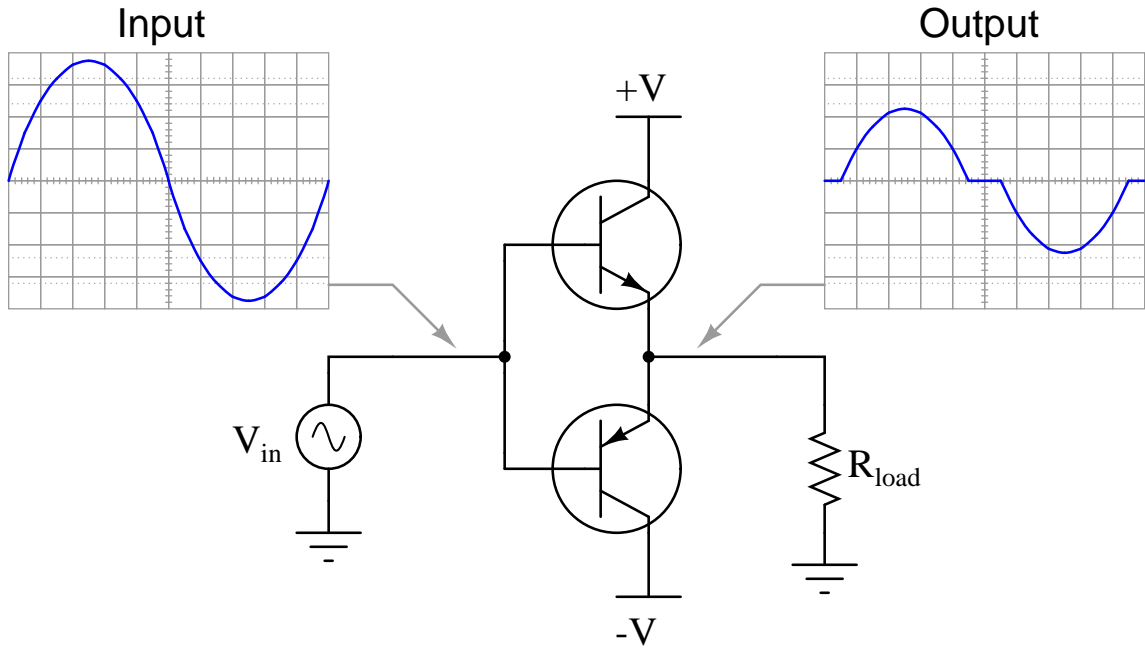

Chapter 5

Questions

This learning module, along with all others in the ModEL collection, is designed to be used in an inverted instructional environment where students independently read¹ the tutorials and attempt to answer questions on their own *prior* to the instructor's interaction with them. In place of lecture², the instructor engages with students in Socratic-style dialogue, probing and challenging their understanding of the subject matter through inquiry.

Answers are not provided for questions within this chapter, and this is by design. Solved problems may be found in the Tutorial and Derivation chapters, instead. The goal here is *independence*, and this requires students to be challenged in ways where others cannot think for them. Remember that you always have the tools of *experimentation* and *computer simulation* (e.g. SPICE) to explore concepts!

The following lists contain ideas for Socratic-style questions and challenges. Upon inspection, one will notice a strong theme of *metacognition* within these statements: they are designed to foster a regular habit of examining one's own thoughts as a means toward clearer thinking. As such these sample questions are useful both for instructor-led discussions as well as for self-study.

¹Technical reading is an essential academic skill for any technical practitioner to possess for the simple reason that the most comprehensive, accurate, and useful information to be found for developing technical competence is in textual form. Technical careers in general are characterized by the need for continuous learning to remain current with standards and technology, and therefore any technical practitioner who cannot read well is handicapped in their professional development. An excellent resource for educators on improving students' reading prowess through intentional effort and strategy is the book *Reading For Understanding – How Reading Apprenticeship Improves Disciplinary Learning in Secondary and College Classrooms* by Ruth Schoenbach, Cynthia Greenleaf, and Lynn Murphy.

²Lecture is popular as a teaching method because it is easy to implement: any reasonably articulate subject matter expert can talk to students, even with little preparation. However, it is also quite problematic. A good lecture always makes complicated concepts seem easier than they are, which is bad for students because it instills a false sense of confidence in their own understanding; reading and re-articulation requires more cognitive effort and serves to verify comprehension. A culture of teaching-by-lecture fosters a debilitating dependence upon direct personal instruction, whereas the challenges of modern life demand independent and critical thought made possible only by gathering information and perspectives from afar. Information presented in a lecture is ephemeral, easily lost to failures of memory and dictation; text is forever, and may be referenced at any time.

GENERAL CHALLENGES FOLLOWING TUTORIAL READING

- Summarize as much of the text as you can in one paragraph of your own words. A helpful strategy is to explain ideas as you would for an intelligent child: as simple as you can without compromising too much accuracy.
- Simplify a particular section of the text, for example a paragraph or even a single sentence, so as to capture the same fundamental idea in fewer words.
- Where did the text make the most sense to you? What was it about the text's presentation that made it clear?
- Identify where it might be easy for someone to misunderstand the text, and explain why you think it could be confusing.
- Identify any new concept(s) presented in the text, and explain in your own words.
- Identify any familiar concept(s) such as physical laws or principles applied or referenced in the text.
- Devise a proof of concept experiment demonstrating an important principle, physical law, or technical innovation represented in the text.
- Devise an experiment to disprove a plausible misconception.
- Did the text reveal any misconceptions you might have harbored? If so, describe the misconception(s) and the reason(s) why you now know them to be incorrect.
- Describe any useful problem-solving strategies applied in the text.
- Devise a question of your own to challenge a reader's comprehension of the text.

GENERAL FOLLOW-UP CHALLENGES FOR ASSIGNED PROBLEMS

- Identify where any fundamental laws or principles apply to the solution of this problem, especially before applying any mathematical techniques.
- Devise a thought experiment to explore the characteristics of the problem scenario, applying known laws and principles to mentally model its behavior.
- Describe in detail your own strategy for solving this problem. How did you identify and organized the given information? Did you sketch any diagrams to help frame the problem?
- Is there more than one way to solve this problem? Which method seems best to you?
- Show the work you did in solving this problem, even if the solution is incomplete or incorrect.
- What would you say was the most challenging part of this problem, and why was it so?
- Was any important information missing from the problem which you had to research or recall?
- Was there any extraneous information presented within this problem? If so, what was it and why did it not matter?
- Examine someone else's solution to identify where they applied fundamental laws or principles.
- Simplify the problem from its given form and show how to solve this simpler version of it. Examples include eliminating certain variables or conditions, altering values to simpler (usually whole) numbers, applying a limiting case (i.e. altering a variable to some extreme or ultimate value).
- For quantitative problems, identify the real-world meaning of all intermediate calculations: their units of measurement, where they fit into the scenario at hand. Annotate any diagrams or illustrations with these calculated values.
- For quantitative problems, try approaching it qualitatively instead, thinking in terms of “increase” and “decrease” rather than definite values.
- For qualitative problems, try approaching it quantitatively instead, proposing simple numerical values for the variables.
- Were there any assumptions you made while solving this problem? Would your solution change if one of those assumptions were altered?
- Identify where it would be easy for someone to go astray in attempting to solve this problem.
- Formulate your own problem based on what you learned solving this one.

GENERAL FOLLOW-UP CHALLENGES FOR EXPERIMENTS OR PROJECTS

- In what way(s) was this experiment or project easy to complete?
- Identify some of the challenges you faced in completing this experiment or project.

- Show how thorough documentation assisted in the completion of this experiment or project.
- Which fundamental laws or principles are key to this system's function?
- Identify any way(s) in which one might obtain false or otherwise misleading measurements from test equipment in this system.
- What will happen if (component X) fails (open/shorted/etc.)?
- What would have to occur to make this system unsafe?

5.1 Conceptual reasoning

These questions are designed to stimulate your analytic and synthetic thinking³. In a Socratic discussion with your instructor, the goal is for these questions to prompt an extended dialogue where assumptions are revealed, conclusions are tested, and understanding is sharpened. Your instructor may also pose additional questions based on those assigned, in order to further probe and refine your conceptual understanding.

Questions that follow are presented to challenge and probe your understanding of various concepts presented in the tutorial. These questions are intended to serve as a guide for the Socratic dialogue between yourself and the instructor. Your instructor’s task is to ensure you have a sound grasp of these concepts, and the questions contained in this document are merely a means to this end. Your instructor may, at his or her discretion, alter or substitute questions for the benefit of tailoring the discussion to each student’s needs. The only absolute requirement is that each student is challenged and assessed at a level equal to or greater than that represented by the documented questions.

It is far more important that you convey your *reasoning* than it is to simply convey a correct answer. For this reason, you should refrain from researching other information sources to answer questions. What matters here is that *you* are doing the thinking. If the answer is incorrect, your instructor will work with you to correct it through proper reasoning. A correct answer without an adequate explanation of how you derived that answer is unacceptable, as it does not aid the learning or assessment process.

You will note a conspicuous lack of answers given for these conceptual questions. Unlike standard textbooks where answers to every other question are given somewhere toward the back of the book, here in these learning modules students must rely on other means to check their work. The best way by far is to debate the answers with fellow students and also with the instructor during the Socratic dialogue sessions intended to be used with these learning modules. Reasoning through challenging questions with other people is an excellent tool for developing strong reasoning skills.

Another means of checking your conceptual answers, where applicable, is to use circuit simulation software to explore the effects of changes made to circuits. For example, if one of these conceptual questions challenges you to predict the effects of altering some component parameter in a circuit, you may check the validity of your work by simulating that same parameter change within software and seeing if the results agree.

³*Analytical* thinking involves the “disassembly” of an idea into its constituent parts, analogous to dissection. *Synthetic* thinking involves the “assembly” of a new idea comprised of multiple concepts, analogous to construction. Both activities are high-level cognitive skills, extremely important for effective problem-solving, necessitating frequent challenge and regular practice to fully develop.

5.1.1 Reading outline and reflections

“Reading maketh a full man; conference a ready man; and writing an exact man” – Francis Bacon

Francis Bacon’s advice is a blueprint for effective education: reading provides the learner with knowledge, writing focuses the learner’s thoughts, and critical dialogue equips the learner to confidently communicate and apply their learning. Independent acquisition and application of knowledge is a powerful skill, well worth the effort to cultivate. To this end, students should read these educational resources closely, journal their own reflections on the reading, and discuss in detail their findings with classmates and instructor(s). You should be able to do all of the following after reading any instructional text:

☑ Briefly **SUMMARIZE THE TEXT** in the form of a journal entry documenting your learning as you progress through the course of study. Share this summary in dialogue with your classmates and instructor. Journaling is an excellent self-test of thorough reading because you cannot clearly express what you have not read or did not comprehend.

☑ Demonstrate **ACTIVE READING STRATEGIES**, including verbalizing your impressions as you read, simplifying long passages to convey the same ideas using fewer words, annotating text and illustrations with your own interpretations, working through mathematical examples shown in the text, cross-referencing passages with relevant illustrations and/or other passages, identifying problem-solving strategies applied by the author, etc. Technical reading is a special case of problem-solving, and so these strategies work precisely because they help solve any problem: paying attention to your own thoughts (metacognition), eliminating unnecessary complexities, identifying what makes sense, paying close attention to details, drawing connections between separated facts, and noting the successful strategies of others.

☑ Identify **IMPORTANT THEMES**, especially **GENERAL LAWS** and **PRINCIPLES**, expounded in the text and express them in the simplest of terms as though you were teaching an intelligent child. This emphasizes connections between related topics and develops your ability to communicate complex ideas to anyone.

☑ Form **YOUR OWN QUESTIONS** based on the reading, and then pose them to your instructor and classmates for their consideration. Anticipate both correct and incorrect answers, the incorrect answer(s) assuming one or more plausible misconceptions. This helps you view the subject from different perspectives to grasp it more fully.

☑ Devise **EXPERIMENTS** to test claims presented in the reading, or to disprove misconceptions. Predict possible outcomes of these experiments, and evaluate their meanings: what result(s) would confirm, and what would constitute disproof? Running mental simulations and evaluating results is essential to scientific and diagnostic reasoning.

☑ Specifically identify any points you found **CONFUSING**. The reason for doing this is to help diagnose misconceptions and overcome barriers to learning.

5.1.2 Foundational concepts

Correct analysis and diagnosis of electric circuits begins with a proper understanding of some basic concepts. The following is a list of some important concepts referenced in this module's full tutorial. Define each of them in your own words, and be prepared to illustrate each of these concepts with a description of a practical example and/or a live demonstration.

Thought experiments as a problem-solving strategy

Amplification

BJT principles

Common-collector amplifier

Common-emitter amplifier

Common-base amplifier

Signal inversion

Beta

Kirchhoff's Voltage Law

Kirchhoff's Current Law

Parasitic effect

Energy

Energy dissipation

Saturation

Reactance

Electromagnetic induction

Transformer

Biasing

Negative feedback

Sourcing

Sinking

Efficiency

Phase

Differential voltage signal

Current mirror

5.1.3 Discrete analysis of a bipolar AND gate

Digital *logic gate* circuits are essentially specialized multi-stage transistor amplifiers designed to amplify signals that are discrete (i.e. either “high” or “low”). As such, their internal operation lends itself well to “limiting cases” analysis where we only consider extreme conditions in order to simplify a complex problem. Analyzing the internal schematics of TTL logic gates is excellent practice for analyzing multi-stage BJT amplifier circuits, which is why this question has been included in this particular module.

Identify the on/off states of the following transistors within this two-input Bipolar (TTL) AND gate (either *on* or *off*) for all combinations of input states. An “AND” gate is one that outputs a “high” state only if *all* its input terminals are also in “high” states. Note that one row of the table has already been completed for you:

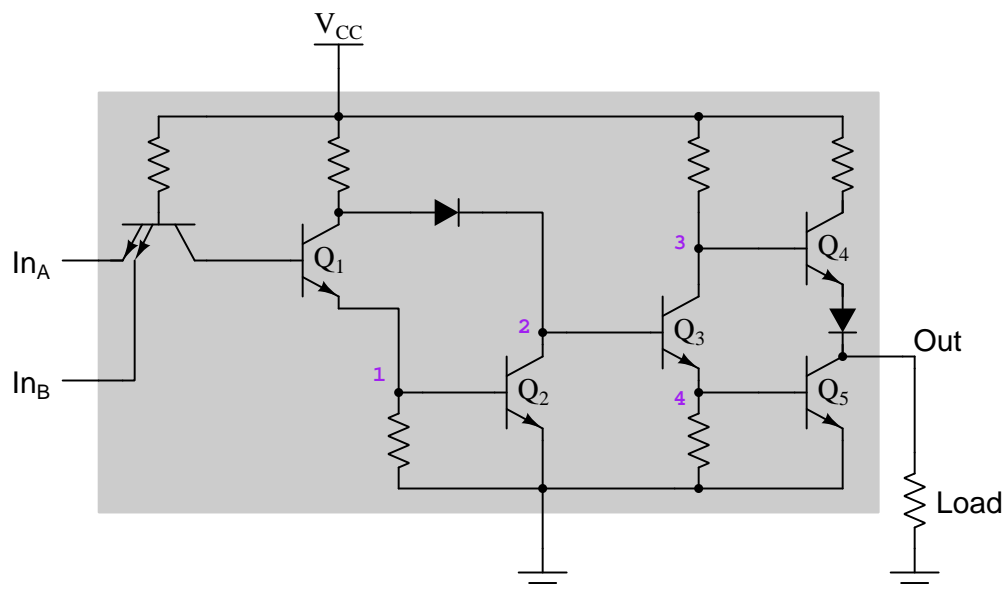

In_A	In_B	Q_1	Q_2	Q_3	Q_4	Q_5
0	0					
0	1					
1	0					
1	1	On	On	Off	On	Off

Note: remember that the double-emitter “transistor” is not really an amplifier in this circuit, but rather is merely a “steering diode” network. IC manufacturers do this because it is easier for them to “copy and paste” bipolar transistor structures in their IC layouts than to build in sets of individual diode junctions.

Challenges

- The unlabeled transistor is not actually functioning as a transistor, but rather represents the *steering diode* network for the gate's input. Explain how this "transistor" is able to function the same as a set of three diodes.
- How does the fact that knowing this is an AND gate assist you in your analysis of its internal states?

5.1.4 Discrete analysis of a bipolar OR gate

Digital *logic gate* circuits are essentially specialized multi-stage transistor amplifiers designed to amplify signals that are discrete (i.e. either “high” or “low”). As such, their internal operation lends itself well to “limiting cases” analysis where we only consider extreme conditions in order to simplify a complex problem. Analyzing the internal schematics of TTL logic gates is excellent practice for analyzing multi-stage BJT amplifier circuits, which is why this question has been included in this particular module.

Identify the on/off states of the following transistors within this two-input Bipolar (TTL) OR gate (either *on* or *off*) for all combinations of input states. An “OR” gate is one that outputs a “high” state if *any one or more* of its inputs are “high”, and outputs a “low” state only if *all* inputs are “low”. Note that one row of the table has already been completed for you:

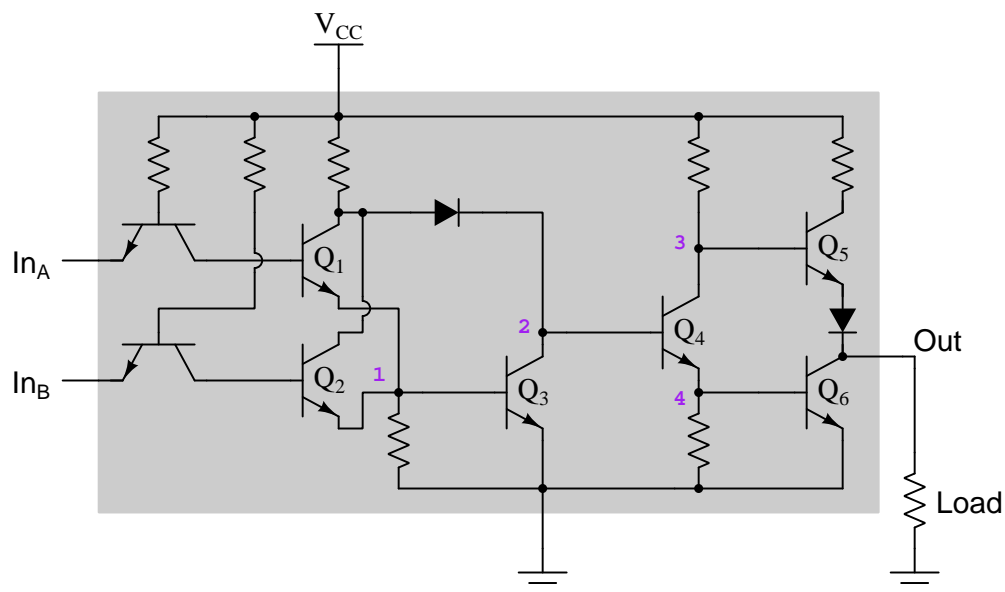

In_A	In_B	Q_1	Q_2	Q_3	Q_4	Q_5	Q_6
0	0						
0	1						
1	0						
1	1	On	On	On	Off	On	Off

Note: remember that the two “transistors” connecting to the input terminals are not really amplifiers in this circuit, but rather serve as “steering diode” networks. IC manufacturers do this because it is easier for them to “copy and paste” bipolar transistor structures in their IC layouts than to build in sets of individual diode junctions.

Challenges

- The unlabeled transistors are not actually functioning as transistors, but rather represent the *steering diode* networks for the gate's inputs. Explain how each of these "transistors" is able to function the same as a pair of diodes.
- How does the fact that knowing this is an OR gate assist you in your analysis of its internal states?

5.1.5 Model 324 differential amplifier qualitative analysis

The following schematic diagram is a simplified version of the integrated circuit (IC) comprising a differential amplifier manufactured under the part number LM324:

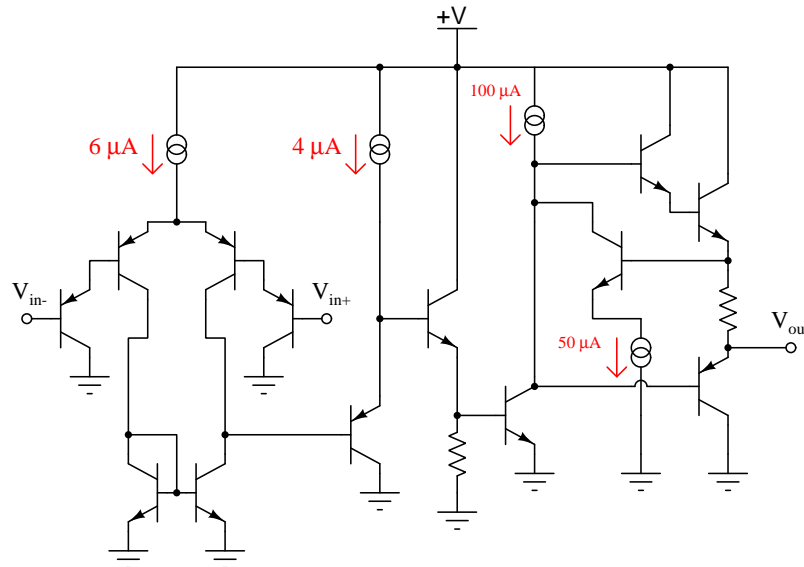

Qualitatively determine what will happen to the output voltage (V_{out}) if the voltage on the inverting input (V_{in-}) increases, and the voltage on the noninverting input (V_{in+}) remains the same (all voltages are positive quantities, referenced to ground). Explain what happens at every stage of this amplifier circuit (voltages increasing or decreasing, currents increasing or decreasing) with this change in input voltage.

Challenges

- Explain how you could apply the “limiting cases” problem-solving technique to this circuit.
- Identify the function of the double-circle symbols in this simplified diagram.
- Identify any current mirrors in this circuit, and explain their purpose.

5.1.6 Identifying component functions

Amplifier #1

Describe the function of each component in this two-stage amplifier circuit:

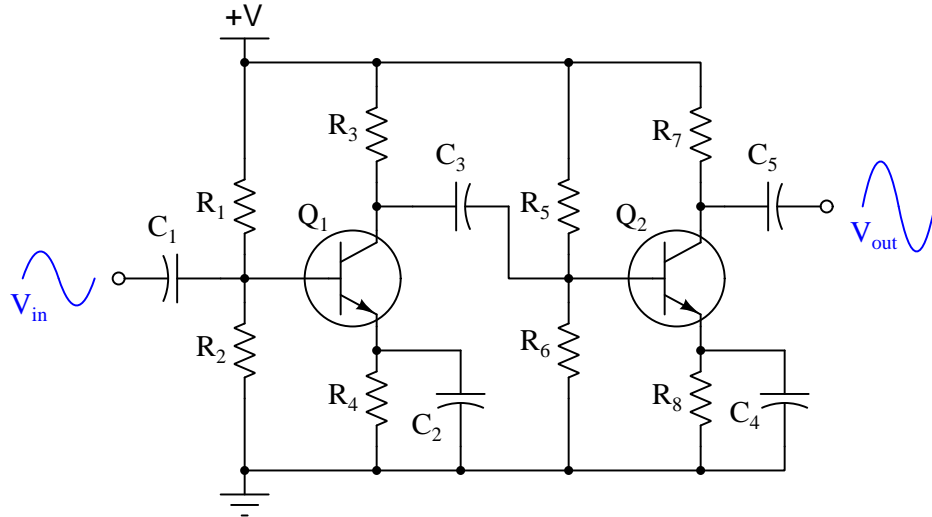

Also, be prepared to explain what the effect of any one component's failure (either open or shorted) will have on the output signal.

Amplifier #2

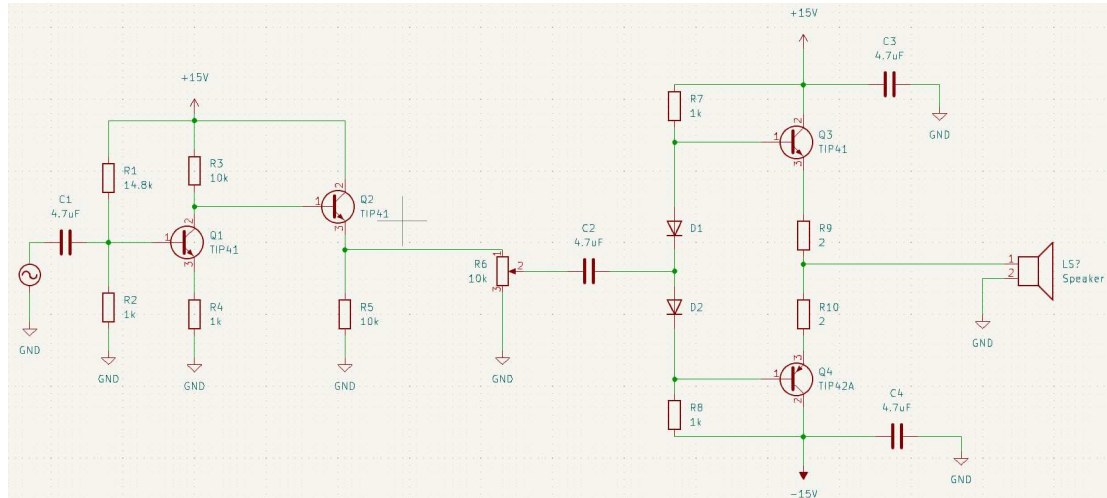

Challenges

- Identify the class (A, B, C, etc.) of each amplifier stage, if possible.

5.1.7 Audio amplifier evaluation

In order to successfully troubleshoot any electronic circuit to the component level, one must have a good understanding of each component's function within the context of that circuit. Transistor amplifiers are no exception to this rule. The following schematic shows a simple, two-stage audio amplifier circuit:

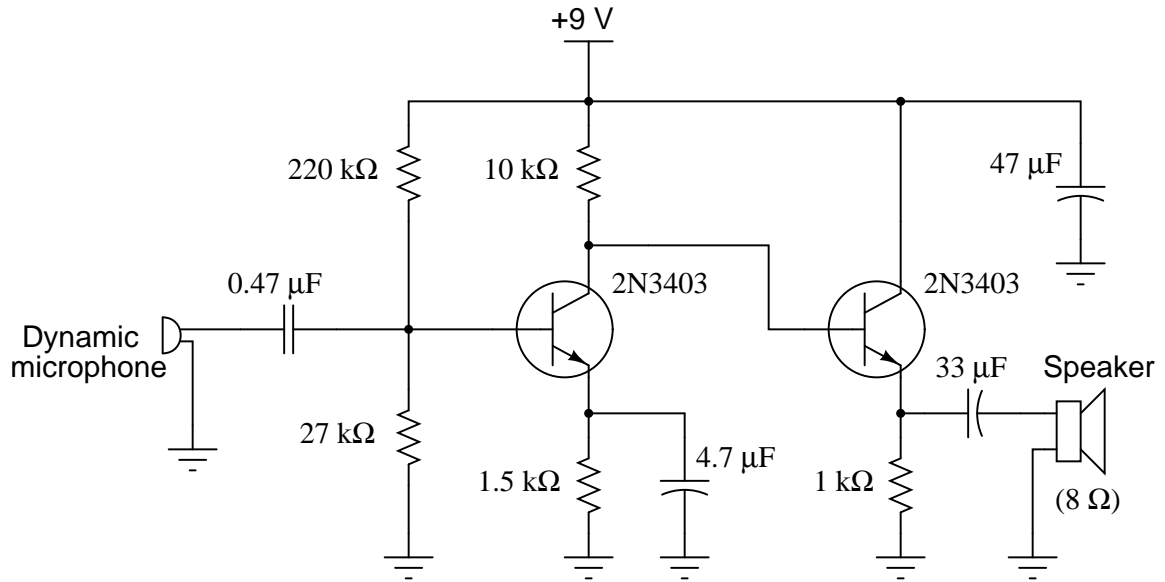

Identify the role of the following components in this audio amplifier circuit:

- The $0.47 \mu\text{F}$ capacitor connected to the microphone
- The $220 \text{ k}\Omega$ and $27 \text{ k}\Omega$ resistor pair
- The $4.7 \mu\text{F}$ electrolytic capacitor connected across the $1.5 \text{ k}\Omega$ resistor
- The $33 \mu\text{F}$ electrolytic capacitor connected to the speaker
- The $47 \mu\text{F}$ electrolytic capacitor connected to the power supply rail

Additionally, answer the following questions concerning the circuit's design:

- What configuration is each stage (common-base, common-collector, common-emitter)?
- Why not just use one transistor stage to drive the speaker? Why is an additional stage necessary?
- What might happen if the $47\ \mu\text{F}$ “decoupling” capacitor were not in the circuit?
- Why does the second stage of the amplifier not need its own voltage divider to set bias voltage as the first stage does?

Challenges

- Identify a practical application for this circuit.

5.1.8 Direct versus capacitive stage coupling

The first amplifier circuit shown here is *direct-coupled*, while the second is *capacitively coupled*.

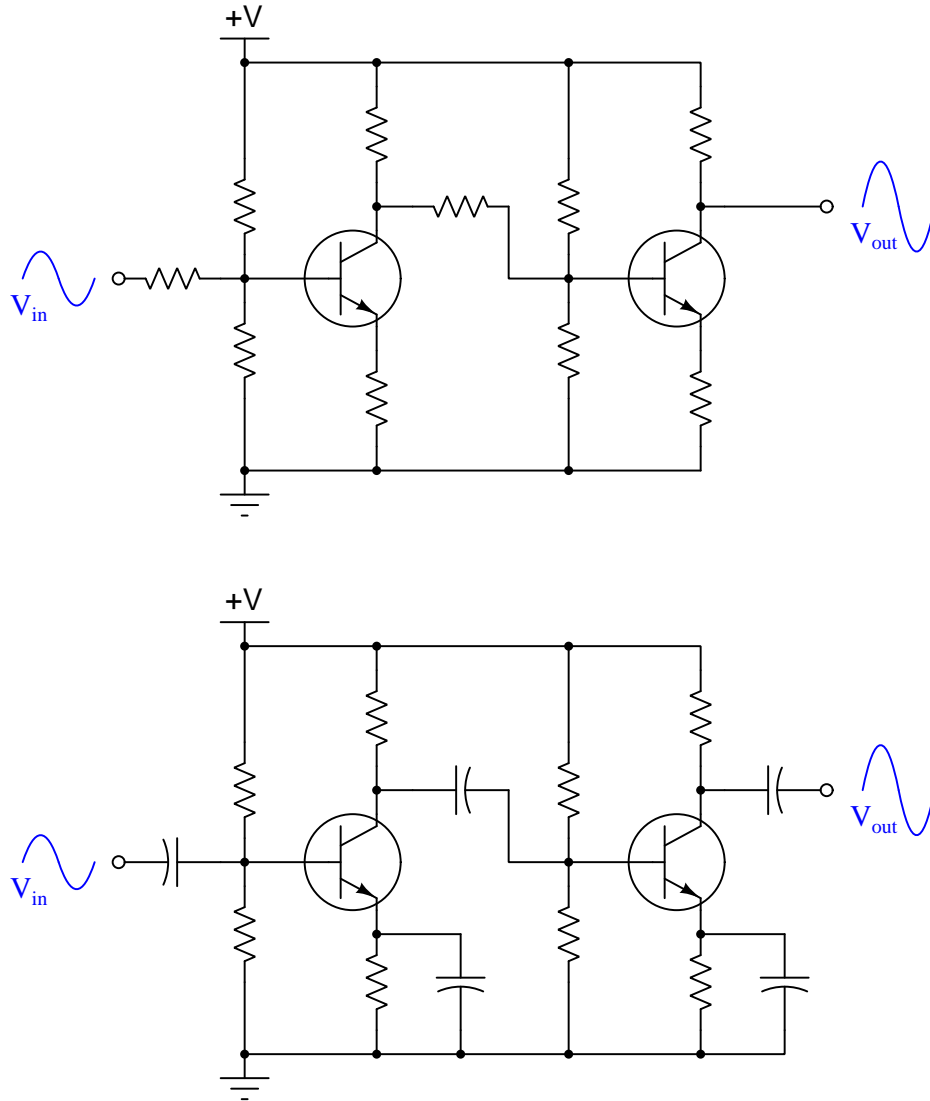

Which of these two designs would be more suitable for use in a DC voltmeter circuit (amplifying a measured DC voltage)? What applications would the *other* amplifier design be suited for?

Challenges

- In each of these amplifier circuits, identify the point at which the signal's phase becomes shifted

by 180° . In other words, show where the voltage signal becomes inverted, and then inverted again, so that the output is in phase with the input.

5.1.9 Transformer stage coupling

This two-stage transistor amplifier circuit is *transformer-coupled*:

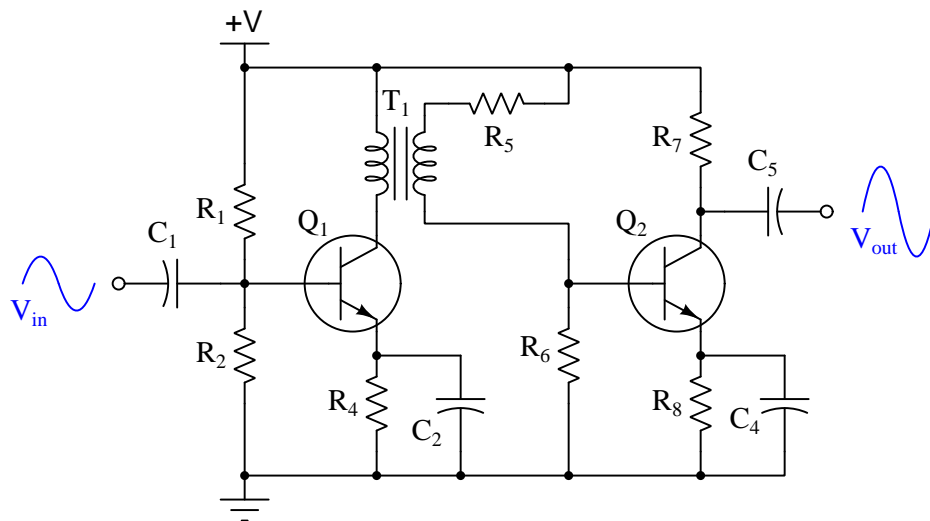

What advantage(s) does a transformer-coupled amplifier have over circuits using other methods of coupling? Are there any disadvantages to using a transformer for signal coupling between transistor stages? Explain in detail.

Challenges

- Label the transformer's polarity using "dot" notation in order to achieve zero inversion of signal from input to output (as shown).

5.1.10 Compensating capacitor

One of the disadvantages of capacitively-coupled amplifier circuits is poor low-frequency response: as the input signal frequency decreases, all capacitive reactances increase, leading to a decreased voltage gain. One solution to this problem is the addition of a capacitor in the collector current path of the initial transistor stage:

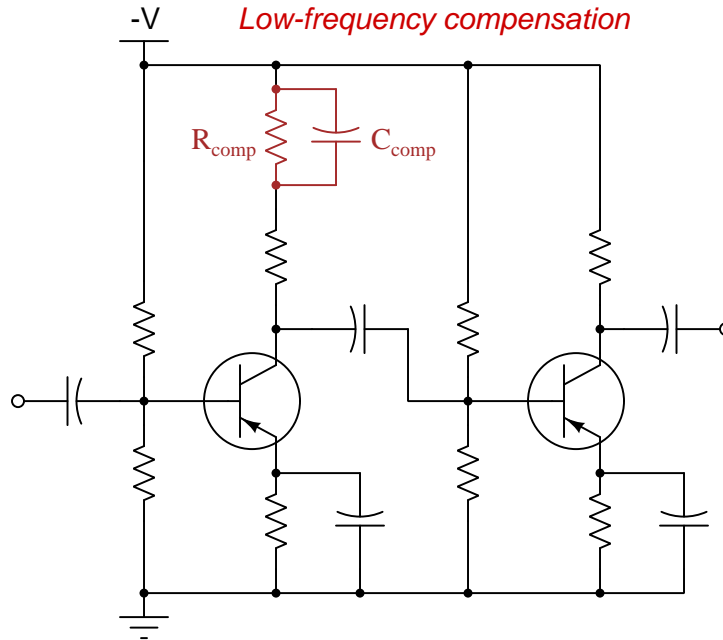

Explain how the presence of this “compensating” capacitor helps to overcome the loss of gain normally experienced as a result of the other capacitors in the circuit.

Challenges

- What will be the effect of the compensating capacitor failing shorted?
- What will be the effect of the compensating resistor failing open?

5.1.11 Paralleled transistors

In some applications where transistors must amplify very high currents, bipolar transistors are paralleled together so that their current ratings add:

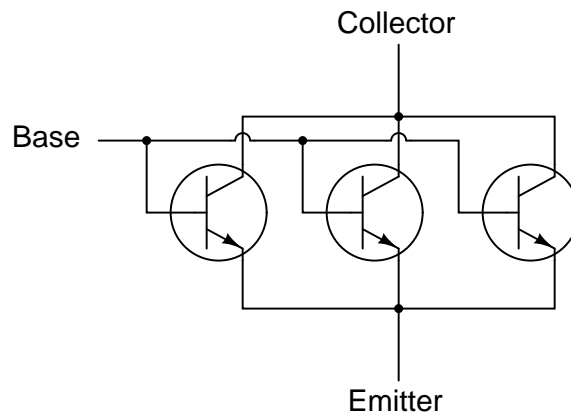

However, if transistors are directly paralleled as shown, reliability problems may develop. A better way of “ganging” multiple transistors together is to connect a low-value *swamping resistor* to each emitter terminal:

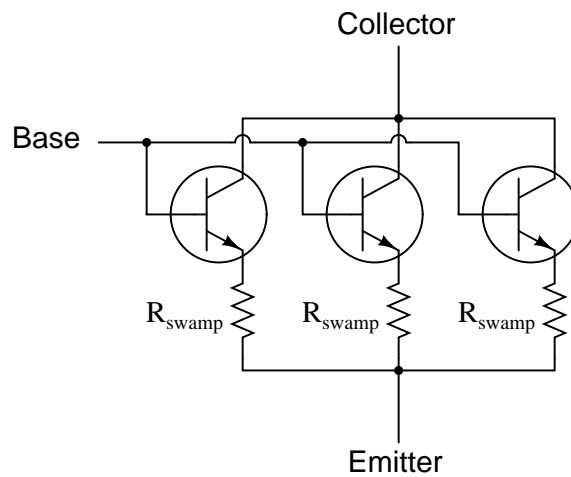

Explain what purpose these resistors serve in a paralleled transistor network. A hint is that the same technique is recommended for paralleling rectifying diodes as well. Also what exactly does “swamping” mean, anyway?

However, if we use MOSFETs instead of BJTs, we do not have to use swamping resistors:

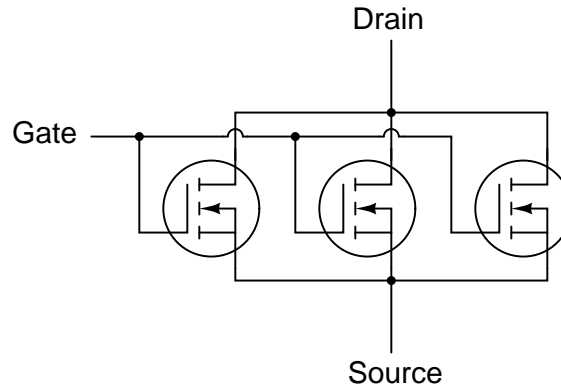

Explain why MOSFETs do not require swamping resistors to help evenly distribute current, while BJTs do.

Challenges

- How would a triplet of paralleled transistors (without swamping resistors) fare if one of the three transistors happened to exhibit a greater β value than the others?

5.1.12 Volume control location

Suppose two engineers were debating where to place a potentiometer in this audio amplifier circuit, to be used as a volume control:

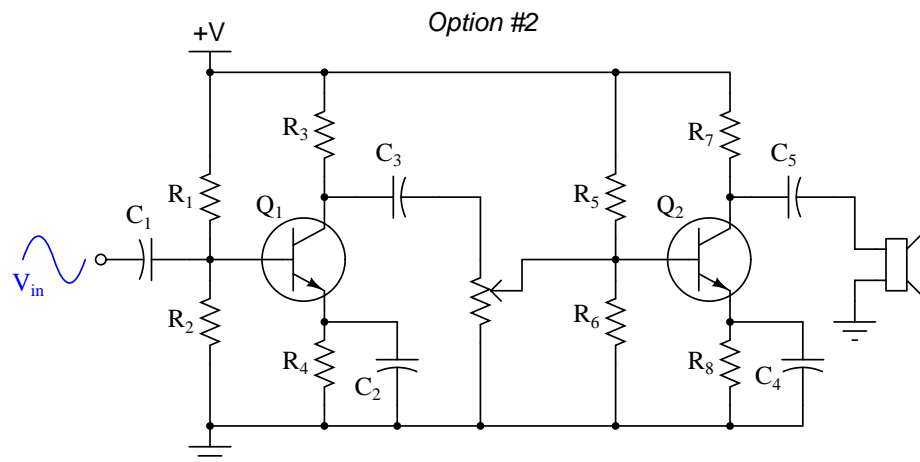
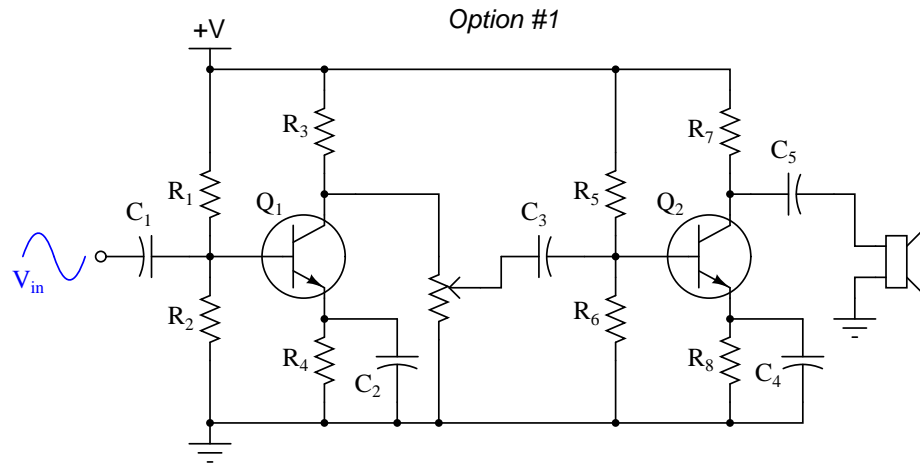

Which option would be better, and why? What ill effects could result from locating the potentiometer in the wrong place in this circuit?

Challenges

- Identify other valid locations for a volume-control potentiometer in this amplifier circuit.

5.1.13 Push-pull amplifier with phase splitter

One design of push-pull audio amplifier uses two identical transistors and a center-tapped transformer to couple power to the load (usually a speaker, in an audio-frequency system):

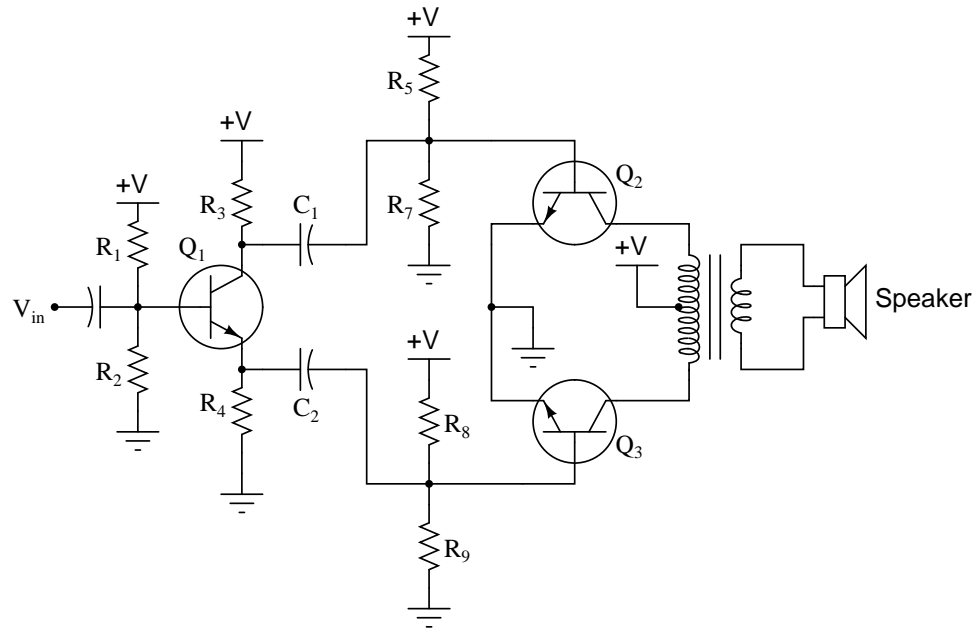

Unlike complementary-pair push-pull amplifier circuits, this circuit absolutely requires a preamplifier stage called a *phase splitter*, comprised here by transistor Q_1 and resistors R_3 and R_4 .

Explain what the purpose of the “phase splitter” circuit is, and why it is necessary to properly drive the power transistors Q_2 and Q_3 .

Challenges

- Typically, the collector and emitter resistors of the phase splitter circuit (R_3 and R_4 in this example) are equally sized. Explain why.

5.1.14 Transformer-coupled push-pull amplifier

Examine this push-pull audio amplifier circuit:

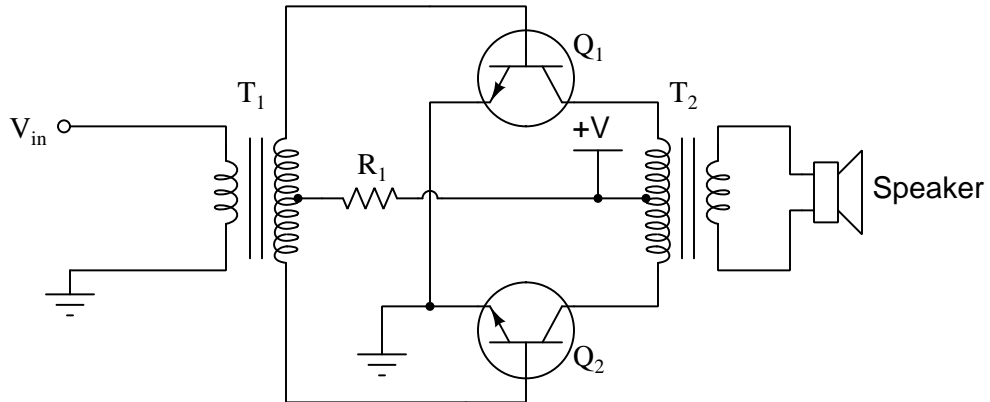

Answer the following questions about this circuit based on your analysis of it:

- How is phase splitting accomplished in this circuit?
- What is the purpose of resistor R_1 ?
- What would happen if resistor R_1 failed open?
- What would happen if the wire connecting the base of transistor Q_2 to the input transformer (T_1) were to fail open?

Challenges

- ???.
- ???.
- ???.

5.1.15 Cascode amplifier

A common wideband transistor amplifier circuit is the *cascode* design, using common-emitter and common-base transistor stages:

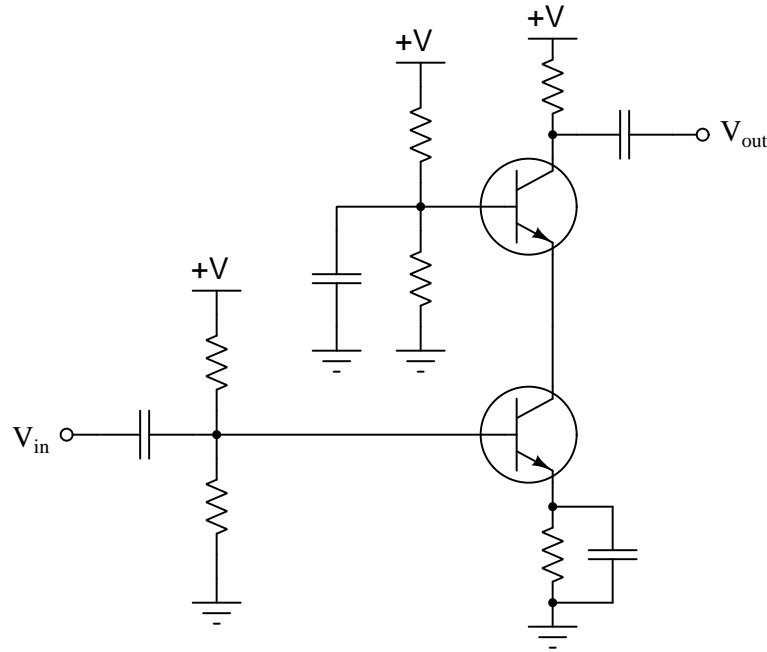

What advantage(s) does the cascode amplifier have over “normal” single- or multi-stage amplifier designs? What, specifically, makes it well suited for high-frequency applications, such as RF (Radio Frequency) signal amplifiers?

Challenges

- Re-design this circuit to use PNP transistors instead of NPN.

5.1.16 Direct-coupled amplifier with negative feedback

Suppose the following three-stage transistor amplifier were constructed:

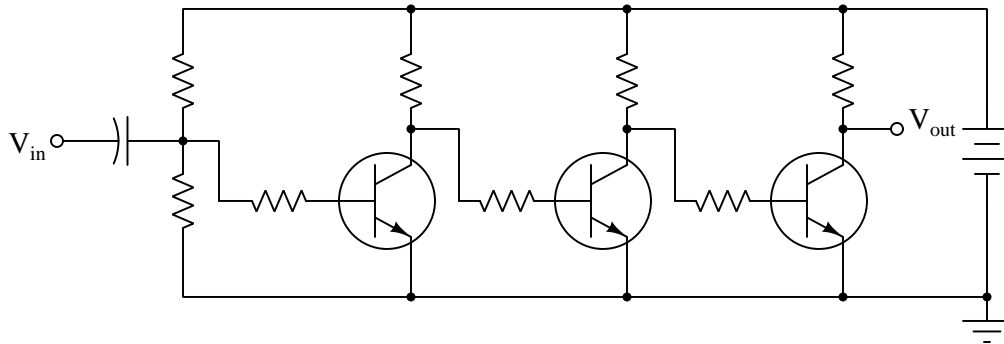

With no emitter swamping resistors anywhere in this circuit, the voltage gain of each stage is guaranteed to be large, but unstable as well. With three stages arranged like this, one feeding into the next, the final voltage gain will be very large, and very unstable.

However, if we add another resistor to the circuit ($R_{feedback}$), something very interesting takes place. Suddenly, the amplifier circuit's overall voltage gain is decreased, but the stability of this gain becomes much improved:

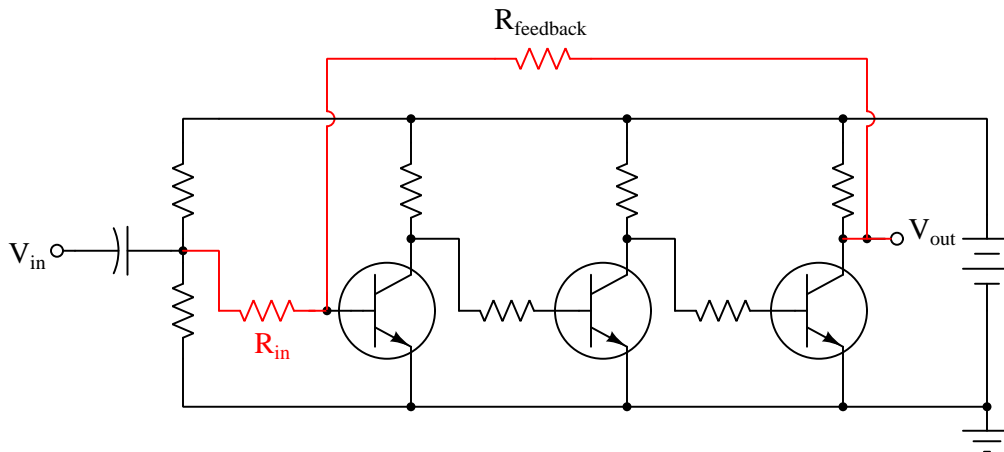

Interestingly, the voltage gain of such a circuit will be nearly equal to the quotient of the two highlighted resistors, $R_{feedback}$ and R_{in} :

$$A_V \approx \frac{R_{feedback}}{R_{in}}$$

This approximation holds true for large variations in individual transistor gain (β) as well as temperature and other factors which would normally wreak havoc in the circuit with no feedback resistor in place.

Describe what role the feedback resistor plays in this circuit, and explain how the addition of negative feedback is an overall benefit to this circuit's performance. Also, explain how you can tell this feedback is *negative* in nature ("degenerative").

Challenges

- How much effect do you suppose the replacement of a transistor with a slightly different β or r'_e parameter would affect each circuit?

5.2 Quantitative reasoning

These questions are designed to stimulate your computational thinking. In a Socratic discussion with your instructor, the goal is for these questions to reveal your mathematical approach(es) to problem-solving so that good technique and sound reasoning may be reinforced. Your instructor may also pose additional questions based on those assigned, in order to observe your problem-solving firsthand.

Mental arithmetic and estimations are strongly encouraged for all calculations, because without these abilities you will be unable to readily detect errors caused by calculator misuse (e.g. keystroke errors).

You will note a conspicuous lack of answers given for these quantitative questions. Unlike standard textbooks where answers to every other question are given somewhere toward the back of the book, here in these learning modules students must rely on other means to check their work. My advice is to use circuit simulation software such as SPICE to check the correctness of quantitative answers. Refer to those learning modules within this collection focusing on SPICE to see worked examples which you may use directly as practice problems for your own study, and/or as templates you may modify to run your own analyses and generate your own practice problems.

Completely worked example problems found in the Tutorial may also serve as “test cases⁴” for gaining proficiency in the use of circuit simulation software, and then once that proficiency is gained you will never need to rely⁵ on an answer key!

⁴In other words, set up the circuit simulation software to analyze the same circuit examples found in the Tutorial. If the simulated results match the answers shown in the Tutorial, it confirms the simulation has properly run. If the simulated results disagree with the Tutorial’s answers, something has been set up incorrectly in the simulation software. Using every Tutorial as practice in this way will quickly develop proficiency in the use of circuit simulation software.

⁵This approach is perfectly in keeping with the instructional philosophy of these learning modules: *teaching students to be self-sufficient thinkers*. Answer keys can be useful, but it is even more useful to your long-term success to have a set of tools on hand for checking your own work, because once you have left school and are on your own, there will no longer be “answer keys” available for the problems you will have to solve.

5.2.1 Miscellaneous physical constants

Note: constants shown in **bold** type are *exact*, not approximations. Values inside of parentheses show one standard deviation (σ) of uncertainty in the final digits: for example, the magnetic permeability of free space value given as $1.25663706212(19) \times 10^{-6}$ H/m represents a center value (i.e. the location parameter) of $1.25663706212 \times 10^{-6}$ Henrys per meter with one standard deviation of uncertainty equal to $0.0000000000019 \times 10^{-6}$ Henrys per meter.

Avogadro's number (N_A) = **6.02214076** $\times 10^{23}$ **per mole** (mol⁻¹)

Boltzmann's constant (k) = **1.380649** $\times 10^{-23}$ **Joules per Kelvin** (J/K)

Electronic charge (e) = **1.602176634** $\times 10^{-19}$ **Coulomb** (C)

Faraday constant (F) = **96,485.33212...** $\times 10^4$ **Coulombs per mole** (C/mol)

Magnetic permeability of free space (μ_0) = $1.25663706212(19) \times 10^{-6}$ Henrys per meter (H/m)

Electric permittivity of free space (ϵ_0) = $8.8541878128(13) \times 10^{-12}$ Farads per meter (F/m)

Characteristic impedance of free space (Z_0) = $376.730313668(57)$ Ohms (Ω)

Gravitational constant (G) = $6.67430(15) \times 10^{-11}$ cubic meters per kilogram-seconds squared (m³/kg-s²)

Molar gas constant (R) = **8.314462618...** **Joules per mole-Kelvin** (J/mol-K) = 0.08205746(14) liters-atmospheres per mole-Kelvin

Planck constant (h) = **6.62607015** $\times 10^{-34}$ **joule-seconds** (J-s)

Stefan-Boltzmann constant (σ) = **5.670374419...** $\times 10^{-8}$ **Watts per square meter-Kelvin⁴** (W/m²·K⁴)

Speed of light in a vacuum (c) = **299,792,458 meters per second** (m/s) = 186282.4 miles per second (mi/s)

Note: All constants taken from NIST data "Fundamental Physical Constants – Complete Listing", from <http://physics.nist.gov/constants>, National Institute of Standards and Technology (NIST), 2018 CODATA Adjustment.

5.2.2 Introduction to spreadsheets

A powerful computational tool you are encouraged to use in your work is a *spreadsheet*. Available on most personal computers (e.g. Microsoft Excel), *spreadsheet* software performs numerical calculations based on number values and formulae entered into cells of a grid. This grid is typically arranged as lettered columns and numbered rows, with each cell of the grid identified by its column/row coordinates (e.g. cell B3, cell A8). Each cell may contain a string of text, a number value, or a mathematical formula. The spreadsheet automatically updates the results of all mathematical formulae whenever the entered number values are changed. This means it is possible to set up a spreadsheet to perform a series of calculations on entered data, and those calculations will be re-done by the computer any time the data points are edited in any way.

For example, the following spreadsheet calculates average speed based on entered values of distance traveled and time elapsed:

	A	B	C	D
1	Distance traveled	46.9	Kilometers	
2	Time elapsed	1.18	Hours	
3	Average speed	= B1 / B2	km/h	
4				
5				

Text labels contained in cells A1 through A3 and cells C1 through C3 exist solely for readability and are not involved in any calculations. Cell B1 contains a sample distance value while cell B2 contains a sample time value. The formula for computing speed is contained in cell B3. Note how this formula begins with an “equals” symbol (=), references the values for distance and speed by lettered column and numbered row coordinates (B1 and B2), and uses a forward slash symbol for division (/). The coordinates B1 and B2 function as *variables*⁶ would in an algebraic formula.

When this spreadsheet is executed, the numerical value 39.74576 will appear in cell B3 rather than the formula = B1 / B2, because 39.74576 is the computed speed value given 46.9 kilometers traveled over a period of 1.18 hours. If a different numerical value for distance is entered into cell B1 or a different value for time is entered into cell B2, cell B3’s value will automatically update. All you need to do is set up the given values and any formulae into the spreadsheet, and the computer will do all the calculations for you.

Cell B3 may be referenced by other formulae in the spreadsheet if desired, since it is a variable just like the given values contained in B1 and B2. This means it is possible to set up an entire chain of calculations, one dependent on the result of another, in order to arrive at a final value. The arrangement of the given data and formulae need not follow any pattern on the grid, which means you may place them anywhere.

⁶Spreadsheets may also provide means to attach text labels to cells for use as variable names (Microsoft Excel simply calls these labels “names”), but for simple spreadsheets such as those shown here it’s usually easier just to use the standard coordinate naming for each cell.

Common⁷ arithmetic operations available for your use in a spreadsheet include the following:

- Addition (+)
- Subtraction (-)
- Multiplication (*)
- Division (/)
- Powers (^)
- Square roots (sqrt())
- Logarithms (ln() , log10())

Parentheses may be used to ensure⁸ proper order of operations within a complex formula. Consider this example of a spreadsheet implementing the *quadratic formula*, used to solve for roots of a polynomial expression in the form of $ax^2 + bx + c$:

$$x = \frac{-b \pm \sqrt{b^2 - 4ac}}{2a}$$

	A	B
1	x_1	= (-B4 + sqrt((B4^2) - (4*B3*B5))) / (2*B3)
2	x_2	= (-B4 - sqrt((B4^2) - (4*B3*B5))) / (2*B3)
3	a =	9
4	b =	5
5	c =	-2

This example is configured to compute roots⁹ of the polynomial $9x^2 + 5x - 2$ because the values of 9, 5, and -2 have been inserted into cells B3, B4, and B5, respectively. Once this spreadsheet has been built, though, it may be used to calculate the roots of *any* second-degree polynomial expression simply by entering the new a , b , and c coefficients into cells B3 through B5. The numerical values appearing in cells B1 and B2 will be automatically updated by the computer immediately following any changes made to the coefficients.

⁷Modern spreadsheet software offers a bewildering array of mathematical functions you may use in your computations. I recommend you consult the documentation for your particular spreadsheet for information on operations other than those listed here.

⁸Spreadsheet programs, like text-based programming languages, are designed to follow standard order of operations by default. However, my personal preference is to use parentheses even where strictly unnecessary just to make it clear to any other person viewing the formula what the intended order of operations is.

⁹Reviewing some algebra here, a *root* is a value for x that yields an overall value of zero for the polynomial. For this polynomial ($9x^2 + 5x - 2$) the two roots happen to be $x = 0.269381$ and $x = -0.82494$, with these values displayed in cells B1 and B2, respectively upon execution of the spreadsheet.

Alternatively, one could break up the long quadratic formula into smaller pieces like this:

$$y = \sqrt{b^2 - 4ac} \quad z = 2a$$

$$x = \frac{-b \pm y}{z}$$

	A	B	C
1	x_1	= (-B4 + C1) / C2	= sqrt((B4^2) - (4*B3*B5))
2	x_2	= (-B4 - C1) / C2	= 2*B3
3	a =	9	
4	b =	5	
5	c =	-2	

Note how the square-root term (y) is calculated in cell C1, and the denominator term (z) in cell C2. This makes the two final formulae (in cells B1 and B2) simpler to interpret. The positioning of all these cells on the grid is completely arbitrary¹⁰ – all that matters is that they properly reference each other in the formulae.

Spreadsheets are particularly useful for situations where the same set of calculations representing a circuit or other system must be repeated for different initial conditions. The power of a spreadsheet is that it automates what would otherwise be a tedious set of calculations. One specific application of this is to simulate the effects of various components within a circuit failing with abnormal values (e.g. a shorted resistor simulated by making its value nearly zero; an open resistor simulated by making its value extremely large). Another application is analyzing the behavior of a circuit design given new components that are out of specification, and/or aging components experiencing drift over time.

¹⁰My personal preference is to locate all the “given” data in the upper-left cells of the spreadsheet grid (each data point flanked by a sensible name in the cell to the left and units of measurement in the cell to the right as illustrated in the first distance/time spreadsheet example), sometimes coloring them in order to clearly distinguish which cells contain entered data versus which cells contain computed results from formulae. I like to place all formulae in cells below the given data, and try to arrange them in logical order so that anyone examining my spreadsheet will be able to figure out *how* I constructed a solution. This is a general principle I believe all computer programmers should follow: *document and arrange your code to make it easy for other people to learn from it.*

5.2.3 Audio amplifier quiescent values

Often times, component failures in transistor circuits will cause significant shifting of DC (quiescent) parameters. This is a benefit for the troubleshooter, as it means many faults may be located simply by measuring DC voltages (with no signal input) and comparing those voltages against what is expected. The most difficult part, though, is determining what DC voltage levels to expect at various points in an amplifier circuit.

Examine this two-stage audio amplifier circuit, and estimate the DC voltages at all the points marked by bold letters and arrows (**A** through **G**), with reference to ground. Assume that conducting PN junctions will drop 0.7 Volts, that loading effects on the voltage divider are negligible, and that the transistor's collector and emitter currents are virtually the same magnitude:

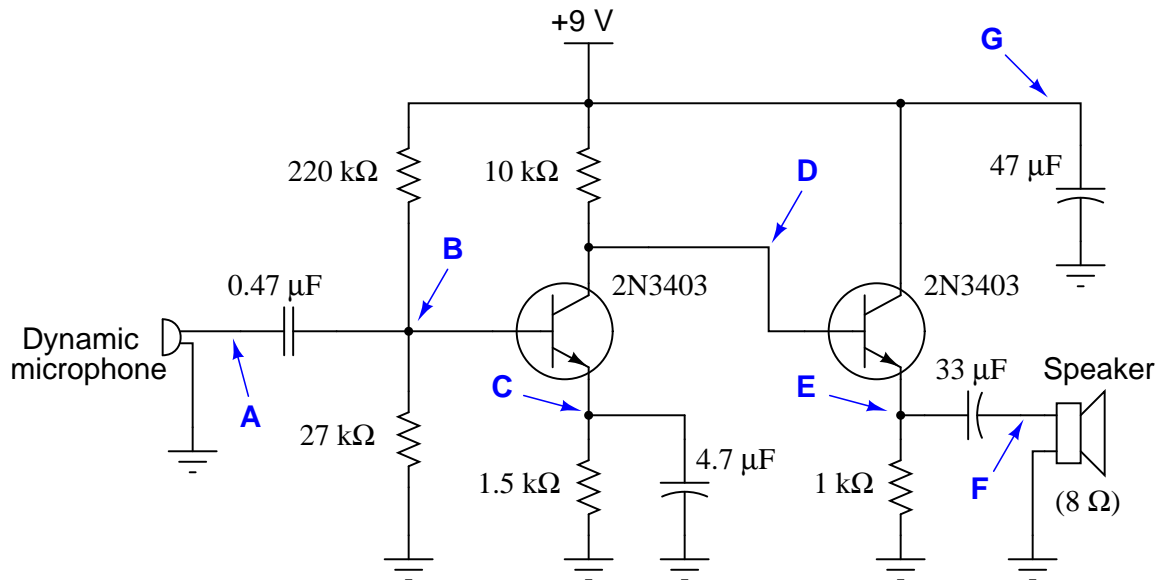

$$V_A \approx$$

$$V_B \approx$$

$$V_C \approx$$

$$V_D \approx$$

$$V_E \approx$$

$$V_F \approx$$

$$V_G \approx$$

Challenges

- Explain why some of these voltages may be precisely known, while all the other DC voltages in this circuit are approximate. Why is this helpful to know when troubleshooting a faulted amplifier circuit?
- Identify a practical application for this circuit.

5.2.4 Approximating voltage gain

Estimate the AC voltage gain of this amplifier circuit:

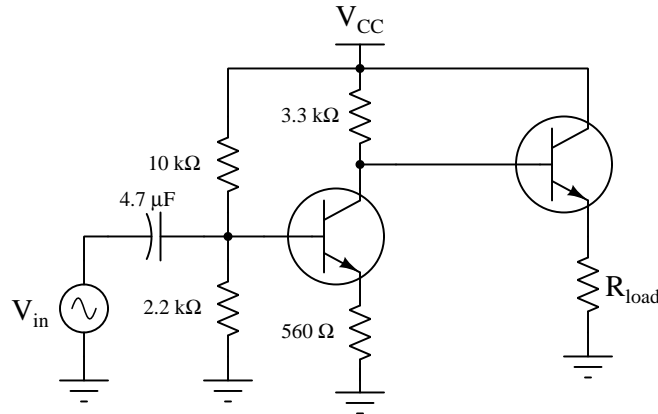

Also, identify whether or not this amplifier will *invert* the phase of the input signal.

Now, identify the component values determining this amplifier's over-all voltage gain:

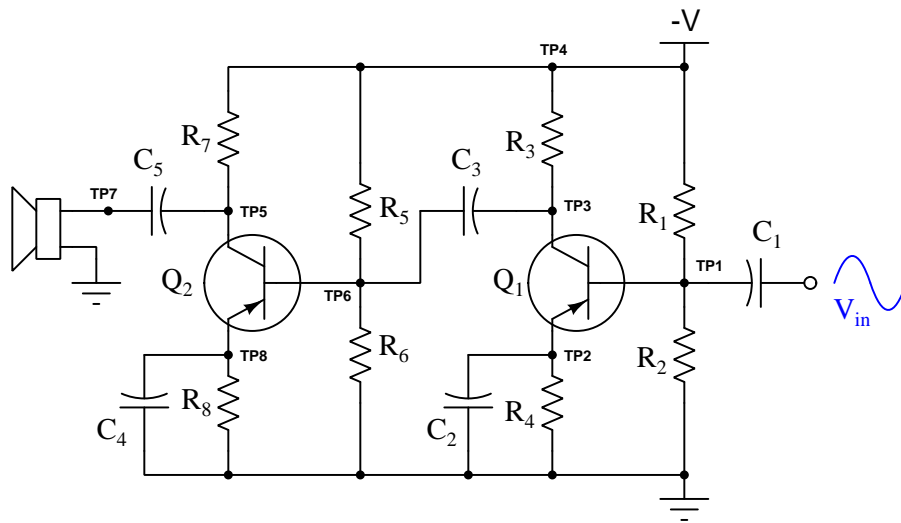

Challenges

- Modify the first amplifier to have greater voltage gain, identifying more than one way to achieve this goal.

5.2.5 Ideal load impedance

Calculate the ideal amount of load impedance for this amplifier circuit, so that maximum power will be delivered to it:

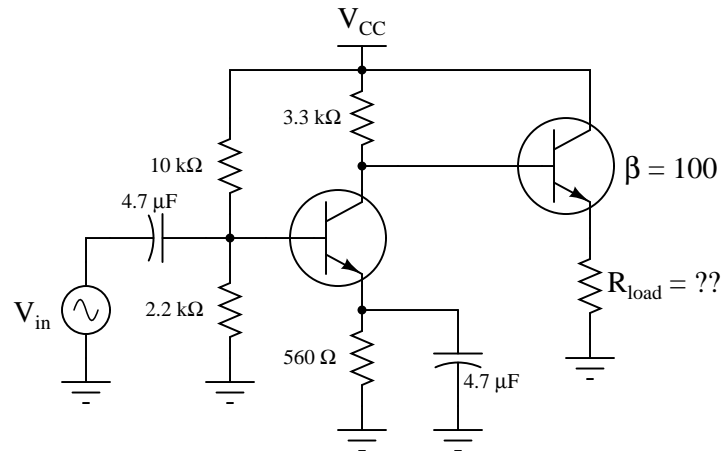

Challenges

- Suppose we needed to drive a load with less impedance than what was calculated above. What might we alter in the circuit to give the amplifier a more suitable Z_{out} for driving this heavier load?

5.2.6 Current mirror calculations

Calculate the approximate amount of current this current mirror circuit will try to maintain through R_{load} , assuming silicon transistors (0.7 Volts forward base-emitter junction drop):

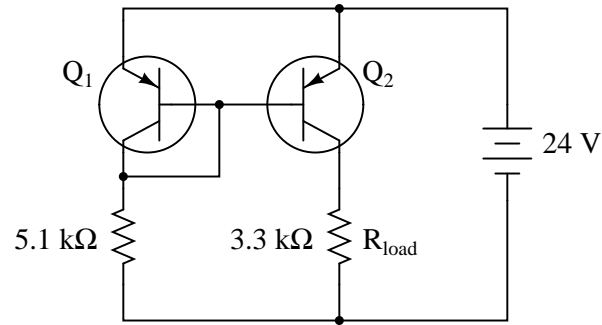

Also, calculate the approximate power dissipation of transistor Q_2 .

Finally, identify how some of the foundational concepts you've studied apply to this circuit: **Ohm's Law**, **Joule's Law**, **Kirchhoff's Voltage Law**, properties of **series** and **parallel** networks, behavior of **PN junctions**, behavior of **BJTs**, the **Shockley diode equation**, etc. Feel free to include any other foundational concepts not listed here.

Challenges

- Will P_{Q_2} increase, decrease, or remain constant as R_{load} increases?
- Will P_{Q_2} increase, decrease, or remain constant if the 5.1 kΩ resistor happens to decrease in value?

5.3 Diagnostic reasoning

These questions are designed to stimulate your deductive and inductive thinking, where you must apply general principles to specific scenarios (deductive) and also derive conclusions about the failed circuit from specific details (inductive). In a Socratic discussion with your instructor, the goal is for these questions to reinforce your recall and use of general circuit principles and also challenge your ability to integrate multiple symptoms into a sensible explanation of what's wrong in a circuit. Your instructor may also pose additional questions based on those assigned, in order to further challenge and sharpen your diagnostic abilities.

As always, your goal is to fully *explain* your analysis of each problem. Simply obtaining a correct answer is not good enough – you must also demonstrate sound reasoning in order to successfully complete the assignment. Your instructor's responsibility is to probe and challenge your understanding of the relevant principles and analytical processes in order to ensure you have a strong foundation upon which to build further understanding.

You will note a conspicuous lack of answers given for these diagnostic questions. Unlike standard textbooks where answers to every other question are given somewhere toward the back of the book, here in these learning modules students must rely on other means to check their work. The best way by far is to debate the answers with fellow students and also with the instructor during the Socratic dialogue sessions intended to be used with these learning modules. Reasoning through challenging questions with other people is an excellent tool for developing strong reasoning skills.

Another means of checking your diagnostic answers, where applicable, is to use circuit simulation software to explore the effects of faults placed in circuits. For example, if one of these diagnostic questions requires that you predict the effect of an open or a short in a circuit, you may check the validity of your work by simulating that same fault (substituting a very high resistance in place of that component for an open, and substituting a very low resistance for a short) within software and seeing if the results agree.

5.3.1 General amplifier troubleshooting tips

Here are a few good steps to take prior to applying any specific troubleshooting strategies to a malfunctioning amplifier circuit:

- Measure the output signal with an oscilloscope.
- Determine if the amplifier is receiving a good input signal.
- Check to see that the amplifier is receiving good-quality power.

Challenges

- Suppose you have no regular input signal for the amplifier to act upon during your diagnosis. How would you simulate a proper input signal for the amplifier, for the purposes of testing it?

5.3.2 Diagnostic strategy for a two-stage audio amplifier

The following amplifier circuit has a problem. Despite the presence of a strong input signal (as verified by an oscilloscope measurement at TP1), there is no sound coming from the speaker:

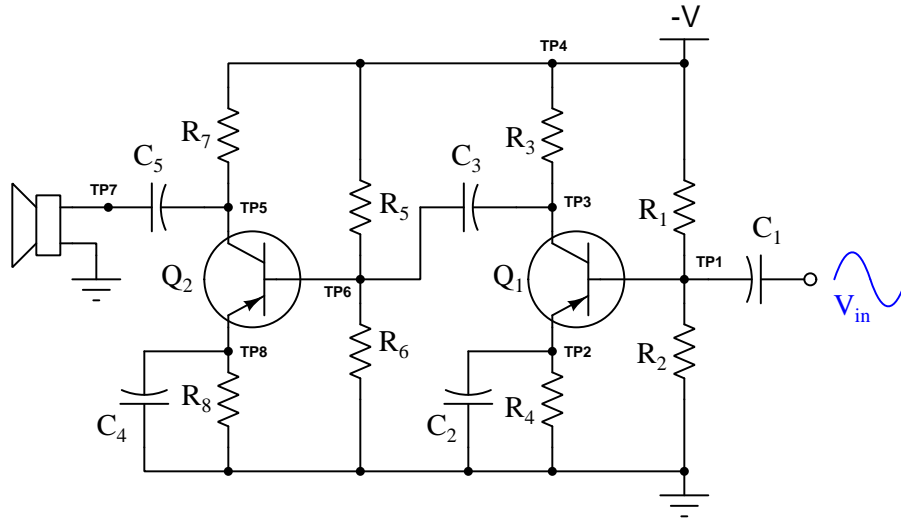

Describe a logical, step-by-step approach to identifying the source of the problem, by taking voltage signal measurements. Remember, the more efficient your troubleshooting technique is (the fewer measurements taken), the better!

Challenges

- Which of the two transistors should have a larger power dissipation rating, and why?

5.3.3 Divide and conquer

The three-stage amplifier shown here has a problem. Despite being supplied with good, “clean” DC power and an adequate input signal to amplify, there is no output signal whatsoever:

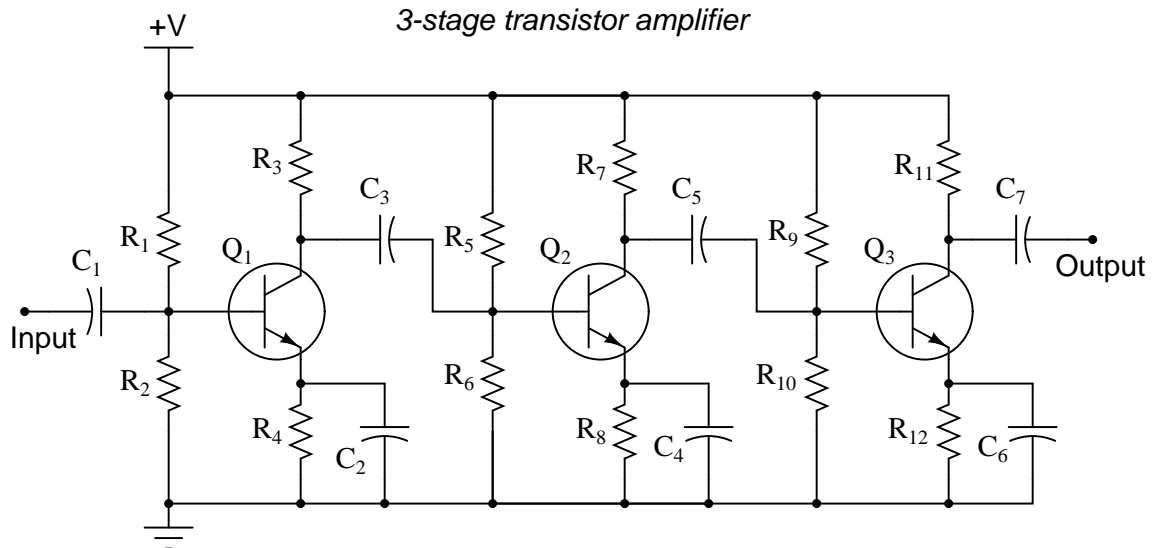

Explain how you would use the “divide and conquer” strategy of troubleshooting to locate the amplification stage where the fault is. (This is where you divide the signal path into different sections, then test for good signal at points along that path so as to narrow the problem down to one-half of the circuit, then to one-quarter of the circuit, etc.)

Show the lines of demarcation where you would divide the circuit into distinct sections, and identify input and output test points for each of those sections.

Challenges

- How well do you suppose this same troubleshooting strategy would work to locate the fault *within* a particular amplification stage?

5.3.4 Effects of faults on quiescent voltages

Examine this audio amplifier schematic closely:

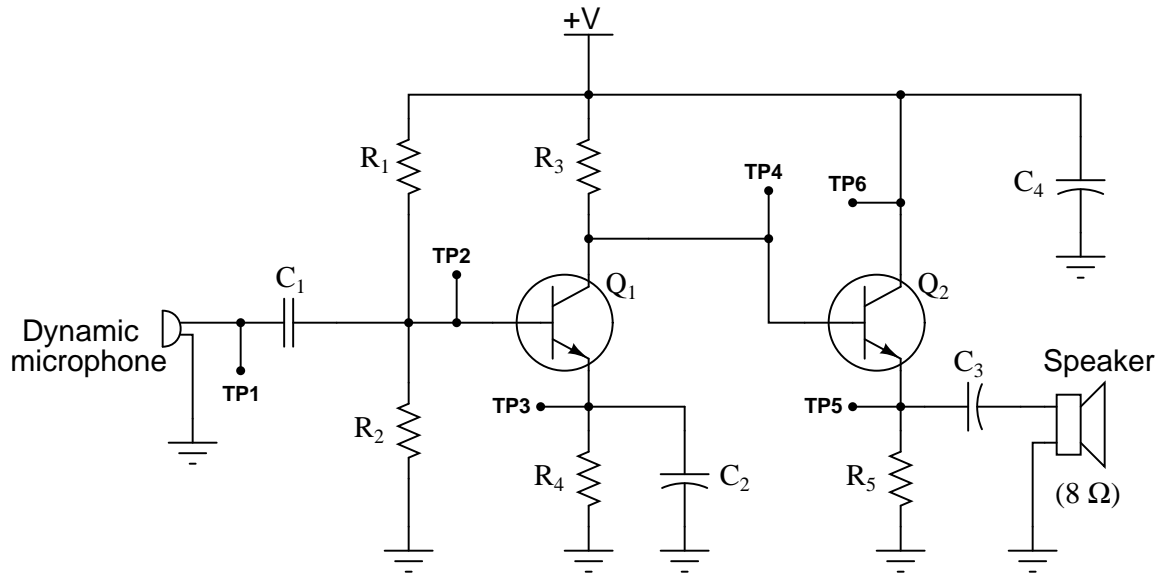

Then, determine whether the DC voltage at each test point (V_{TP1} through V_{TP6}) with respect to ground will increase, decrease, or remain the same for each of the given fault conditions:

- R_1 failed open –
- R_2 failed open –
- R_3 failed open –
- R_4 failed open –
- R_5 failed open –
- Short between TP2 and ground –
- C_2 failed shorted –
- Q_1 collector failed open –

Challenges

- Explain why some of these voltage values never change, regardless of the fault.

5.3.5 Amplifier signal clipping

Suppose you were troubleshooting the following amplifier circuit, and found the output signal to be “clipped” on the negative peaks:

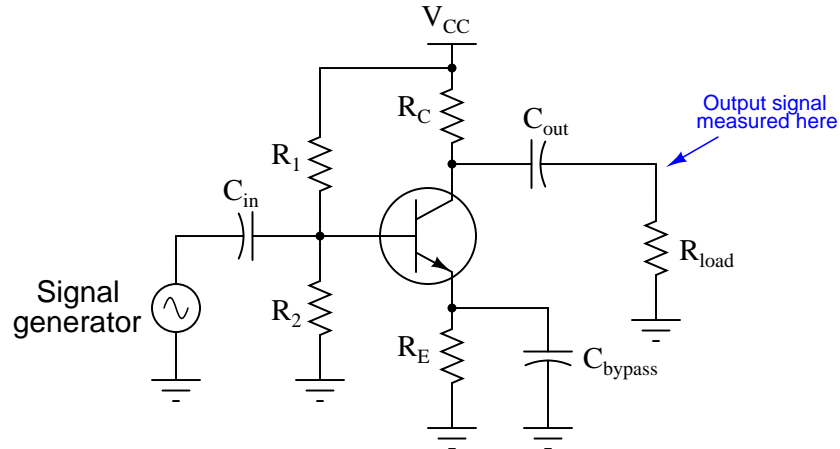

Output signal:

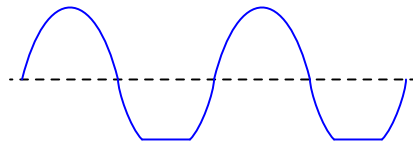

If you knew that this amplifier was a new design, and might not have all its components properly sized, what type of problem would you suspect in the circuit? Please be as specific as possible.

Challenges

- Some signal generators are equipped with a “DC offset” adjustment which is useful for biasing their output signals. Could an improperly-set DC offset on the signal generator be the fault here?

5.3.6 Symmetrical amplifier signal clipping

Suppose you were troubleshooting the following amplifier circuit, and found the output signal to be symmetrically “clipped” on both the positive and negative peaks:

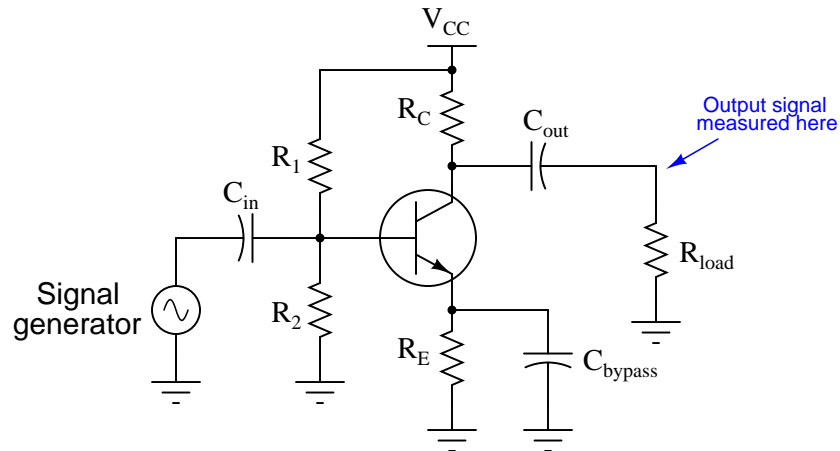

Output signal:

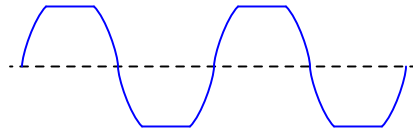

If you knew that this amplifier was a new design, and might not have all its components properly sized, what type of problem would you suspect in the circuit? Please be as specific as possible.

Challenges

- Electric guitar preamplifiers are actually designed to “clip” the waveform like this intentionally, to produce the distinctive distortion sound of a lead rock guitar. What could you alter in this circuit to make it “clip” even harder than it is now?

5.3.7 Push-pull amplifier distortion

This class-B audio power amplifier circuit has a problem: its output is very distorted, resembling half of a sine wave when tested with an input signal from a function generator:

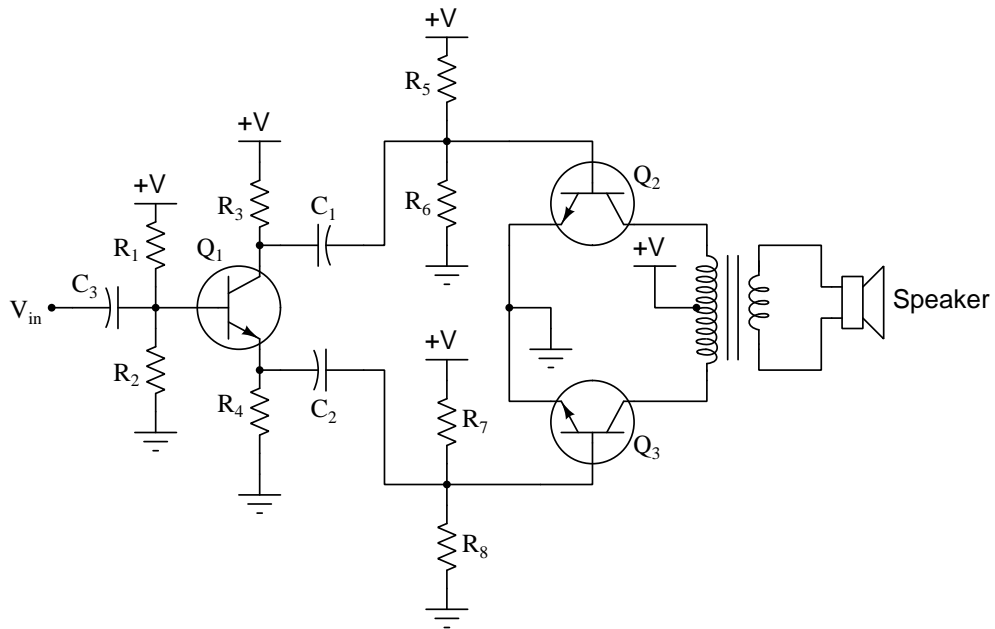

Output signal:

(measured by oscilloscope at speaker terminals)



List some of the possible faults in this system, based on the output signal shown by the oscilloscope. Also, determine which components, if any, are known to be good based on the same data:

Possible faults in the system:

-
-
-

Components known to be in good order:

-
-
-

Challenges

- Suppose that after testing this amplifier on your workbench with a “dummy” load ($8\ \Omega$ resistor connected to the speaker terminals), you happened to notice that transistor Q_2 was slightly warm to the touch, while transistor Q_3 was still at room temperature. What would this extra information indicate about the amplifier’s problem?
- Describe the potential safety hazards involved with touching a power transistor in an operating circuit. If you wished to compare the operating temperature of these two transistors, how could you safely do it?

5.3.8 Amplifier simulation program

The following computer program (written in C) simulates a simple swamped-emitter common-emitter transistor amplifier with a sinusoidal AC input signal of 1 Volt peak:

```
#include <stdio.h>
#include <math.h>

int main (void)
{
    float r1 = 20e3, r2 = 4.7e3, rc = 1e3, re = 330, vcc = 20;
    float vb, ve, vin, peak = 1.0 , vout, angle;

    printf("Angle , Vout\n");

    for (angle = 0 ; angle <= 2 * M_PI ; angle = angle + M_PI/18)
    {
        vin = peak * sin(angle); // Simulates a sine wave signal

        vb = vcc * r2 / (r1 + r2) + vin;
        ve = vb - 0.7;
        vout = vcc - (rc * ve / re);

        if (vout < ve)
            vout = ve;

        if (vout > vcc)
            vout = vcc;

        printf("%f , %f\n", angle, vout);
    }

    return 0;
}
```

This program's output is a stream of two-column comma-separated text values suitable for plotting using a spreadsheet program. Here we see the plot generated by the example code:

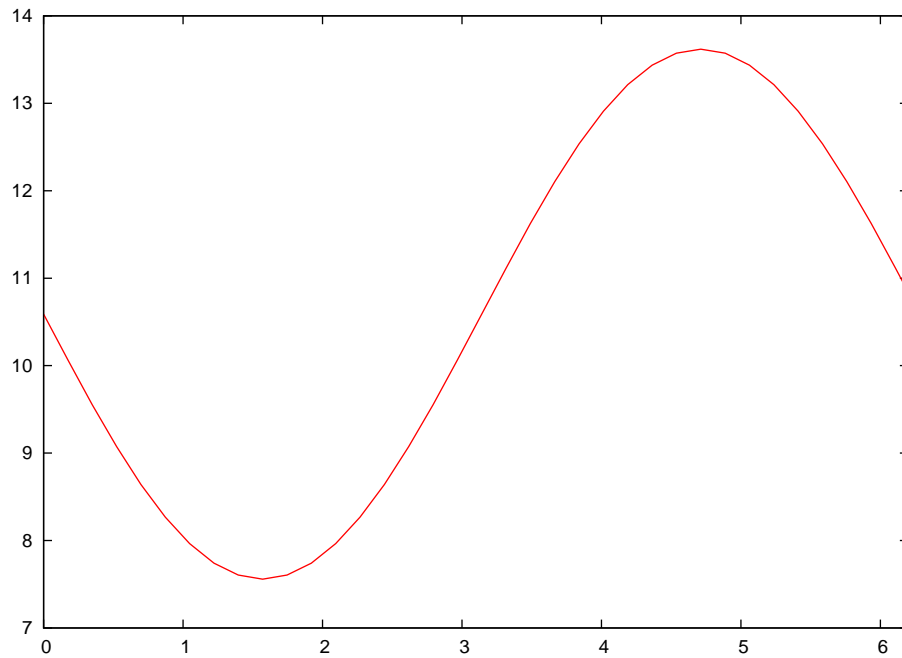

Experiment with this program by editing the code and re-running the simulation until you achieve *clipping* on the output signal. Identify what conditions cause it to clip on the positive peak versus on the negative peak.

Challenges

- Why is the output signal's waveform phase-shifted from the input signal?

Appendix A

Problem-Solving Strategies

The ability to solve complex problems is arguably one of the most valuable skills one can possess, and this skill is particularly important in any science-based discipline.

- Study principles, not procedures. Don't be satisfied with merely knowing how to compute solutions – learn *why* those solutions work.
- Identify what it is you need to solve, identify all relevant data, identify all units of measurement, identify any general principles or formulae linking the given information to the solution, and then identify any “missing pieces” to a solution. Annotate all diagrams with this data.
- Sketch a diagram to help visualize the problem. When building a real system, always devise a plan for that system and analyze its function *before* constructing it.
- Follow the units of measurement and meaning of every calculation. If you are ever performing mathematical calculations as part of a problem-solving procedure, and you find yourself unable to apply each and every intermediate result to some aspect of the problem, it means you don't understand what you are doing. Properly done, every mathematical result should have practical meaning for the problem, and not just be an abstract number. You should be able to identify the proper units of measurement for each and every calculated result, and show where that result fits into the problem.
- Perform “thought experiments” to explore the effects of different conditions for theoretical problems. When troubleshooting real systems, perform *diagnostic tests* rather than visually inspecting for faults, the best diagnostic test being the one giving you the most information about the nature and/or location of the fault with the fewest steps.
- Simplify the problem until the solution becomes obvious, and then use that obvious case as a model to follow in solving the more complex version of the problem.
- Check for exceptions to see if your solution is incorrect or incomplete. A good solution will work for *all* known conditions and criteria. A good example of this is the process of testing scientific hypotheses: the task of a scientist is not to find support for a new idea, but rather to *challenge* that new idea to see if it holds up under a battery of tests. The philosophical

principle of *reductio ad absurdum* (i.e. disproving a general idea by finding a specific case where it fails) is useful here.

- Work “backward” from a hypothetical solution to a new set of given conditions.
- Add quantities to problems that are qualitative in nature, because sometimes a little math helps illuminate the scenario.
- Sketch graphs illustrating how variables relate to each other. These may be quantitative (i.e. with realistic number values) or qualitative (i.e. simply showing increases and decreases).
- Treat quantitative problems as qualitative in order to discern the relative magnitudes and/or directions of change of the relevant variables. For example, try determining what happens if a certain variable were to increase or decrease before attempting to precisely calculate quantities: how will each of the dependent variables respond, by increasing, decreasing, or remaining the same as before?
- Consider limiting cases. This works especially well for qualitative problems where you need to determine which direction a variable will change. Take the given condition and magnify that condition to an extreme degree as a way of simplifying the direction of the system’s response.
- Check your work. This means regularly testing your conclusions to see if they make sense. This does *not* mean repeating the same steps originally used to obtain the conclusion(s), but rather to use some other means to check validity. Simply repeating procedures often leads to *repeating the same errors* if any were made, which is why alternative paths are better.

Appendix B

Instructional philosophy

“The unexamined circuit is not worth energizing” – Socrates (if he had taught electricity)

These learning modules, although useful for self-study, were designed to be used in a formal learning environment where a subject-matter expert challenges students to digest the content and exercise their critical thinking abilities in the answering of questions and in the construction and testing of working circuits.

The following principles inform the instructional and assessment philosophies embodied in these learning modules:

- The first goal of education is to enhance clear and independent thought, in order that every student reach their fullest potential in a highly complex and inter-dependent world. Robust reasoning is *always* more important than particulars of any subject matter, because its application is universal.
- Literacy is fundamental to independent learning and thought because text continues to be the most efficient way to communicate complex ideas over space and time. Those who cannot read with ease are limited in their ability to acquire knowledge and perspective.
- Articulate communication is fundamental to work that is complex and interdisciplinary.
- Faulty assumptions and poor reasoning are best corrected through challenge, not presentation. The rhetorical technique of *reductio ad absurdum* (disproving an assertion by exposing an absurdity) works well to discipline student’s minds, not only to correct the problem at hand but also to learn how to detect and correct future errors.
- Important principles should be repeatedly explored and widely applied throughout a course of study, not only to reinforce their importance and help ensure their mastery, but also to showcase the interconnectedness and utility of knowledge.

These learning modules were expressly designed to be used in an “inverted” teaching environment¹ where students first read the introductory and tutorial chapters on their own, then individually attempt to answer the questions and construct working circuits according to the experiment and project guidelines. The instructor never lectures, but instead meets regularly with each individual student to review their progress, answer questions, identify misconceptions, and challenge the student to new depths of understanding through further questioning. Regular meetings between instructor and student should resemble a Socratic² dialogue, where questions serve as scalpels to dissect topics and expose assumptions. The student passes each module only after consistently demonstrating their ability to logically analyze and correctly apply all major concepts in each question or project/experiment. The instructor must be vigilant in probing each student’s understanding to ensure they are truly *reasoning* and not just *memorizing*. This is why “Challenge” points appear throughout, as prompts for students to think deeper about topics and as starting points for instructor queries. Sometimes these challenge points require additional knowledge that hasn’t been covered in the series to answer in full. This is okay, as the major purpose of the Challenges is to stimulate analysis and synthesis on the part of each student.

The instructor must possess enough mastery of the subject matter and awareness of students’ reasoning to generate their own follow-up questions to practically any student response. Even completely correct answers given by the student should be challenged by the instructor for the purpose of having students practice articulating their thoughts and defending their reasoning. Conceptual errors committed by the student should be exposed and corrected not by direct instruction, but rather by reducing the errors to an absurdity³ through well-chosen questions and thought experiments posed by the instructor. Becoming proficient at this style of instruction requires time and dedication, but the positive effects on critical thinking for both student and instructor are spectacular.

An inspection of these learning modules reveals certain unique characteristics. One of these is a bias toward thorough explanations in the tutorial chapters. Without a live instructor to explain concepts and applications to students, the text itself must fulfill this role. This philosophy results in lengthier explanations than what you might typically find in a textbook, each step of the reasoning process fully explained, including footnotes addressing common questions and concerns students raise while learning these concepts. Each tutorial seeks to not only explain each major concept in sufficient detail, but also to explain the logic of each concept and how each may be developed

¹In a traditional teaching environment, students first encounter new information via *lecture* from an expert, and then independently apply that information via *homework*. In an “inverted” course of study, students first encounter new information via *homework*, and then independently apply that information under the scrutiny of an expert. The expert’s role in lecture is to simply *explain*, but the expert’s role in an inverted session is to *challenge, critique*, and if necessary *explain* where gaps in understanding still exist.

²Socrates is a figure in ancient Greek philosophy famous for his unflinching style of questioning. Although he authored no texts, he appears as a character in Plato’s many writings. The essence of Socratic philosophy is to leave no question unexamined and no point of view unchallenged. While purists may argue a topic such as electric circuits is too narrow for a true Socratic-style dialogue, I would argue that the essential thought processes involved with scientific reasoning on *any* topic are not far removed from the Socratic ideal, and that students of electricity and electronics would do very well to challenge assumptions, pose thought experiments, identify fallacies, and otherwise employ the arsenal of critical thinking skills modeled by Socrates.

³This rhetorical technique is known by the Latin phrase *reductio ad absurdum*. The concept is to expose errors by counter-example, since only one solid counter-example is necessary to disprove a universal claim. As an example of this, consider the common misconception among beginning students of electricity that voltage cannot exist without current. One way to apply *reductio ad absurdum* to this statement is to ask how much current passes through a fully-charged battery connected to nothing (i.e. a clear example of voltage existing without current).

from “first principles”. Again, this reflects the goal of developing clear and independent thought in students’ minds, by showing how clear and logical thought was used to forge each concept. Students benefit from witnessing a model of clear thinking in action, and these tutorials strive to be just that.

Another characteristic of these learning modules is a lack of step-by-step instructions in the Project and Experiment chapters. Unlike many modern workbooks and laboratory guides where step-by-step instructions are prescribed for each experiment, these modules take the approach that students must learn to closely read the tutorials and apply their own reasoning to identify the appropriate experimental steps. Sometimes these steps are plainly declared in the text, just not as a set of enumerated points. At other times certain steps are implied, an example being assumed competence in test equipment use where the student should not need to be told *again* how to use their multimeter because that was thoroughly explained in previous lessons. In some circumstances no steps are given at all, leaving the entire procedure up to the student.

This lack of prescription is not a flaw, but rather a feature. Close reading and clear thinking are foundational principles of this learning series, and in keeping with this philosophy all activities are designed to *require* those behaviors. Some students may find the lack of prescription frustrating, because it demands more from them than what their previous educational experiences required. This frustration should be interpreted as an unfamiliarity with autonomous thinking, a problem which must be corrected if the student is ever to become a self-directed learner and effective problem-solver. Ultimately, the need for students to read closely and think clearly is more important both in the near-term and far-term than any specific facet of the subject matter at hand. If a student takes longer than expected to complete a module because they are forced to outline, digest, and reason on their own, so be it. The future gains enjoyed by developing this mental discipline will be well worth the additional effort and delay.

Another feature of these learning modules is that they do not treat topics in isolation. Rather, important concepts are introduced early in the series, and appear repeatedly as stepping-stones toward other concepts in subsequent modules. This helps to avoid the “compartmentalization” of knowledge, demonstrating the inter-connectedness of concepts and simultaneously reinforcing them. Each module is fairly complete in itself, reserving the beginning of its tutorial to a review of foundational concepts.

This methodology of assigning text-based modules to students for digestion and then using Socratic dialogue to assess progress and hone students’ thinking was developed over a period of several years by the author with his Electronics and Instrumentation students at the two-year college level. While decidedly unconventional and sometimes even unsettling for students accustomed to a more passive lecture environment, this instructional philosophy has proven its ability to convey conceptual mastery, foster careful analysis, and enhance employability so much better than lecture that the author refuses to ever teach by lecture again.

Problems which often go undiagnosed in a lecture environment are laid bare in this “inverted” format where students must articulate and logically defend their reasoning. This, too, may be unsettling for students accustomed to lecture sessions where the instructor cannot tell for sure who comprehends and who does not, and this vulnerability necessitates sensitivity on the part of the “inverted” session instructor in order that students never feel discouraged by having their errors exposed. *Everyone* makes mistakes from time to time, and learning is a lifelong process! Part of the instructor’s job is to build a culture of learning among the students where errors are not seen as shameful, but rather as opportunities for progress.

To this end, instructors managing courses based on these modules should adhere to the following principles:

- Student questions are always welcome and demand thorough, honest answers. The only type of question an instructor should refuse to answer is one the student should be able to easily answer on their own. Remember, *the fundamental goal of education is for each student to learn to think clearly and independently*. This requires hard work on the part of the student, which no instructor should ever circumvent. Anything done to bypass the student's responsibility to do that hard work ultimately limits that student's potential and thereby does real harm.
- It is not only permissible, but encouraged, to answer a student's question by asking questions in return, these follow-up questions designed to guide the student to reach a correct answer through their own reasoning.
- All student answers demand to be challenged by the instructor and/or by other students. This includes both correct and incorrect answers – the goal is to practice the articulation and defense of one's own reasoning.
- No reading assignment is deemed complete unless and until the student demonstrates their ability to accurately summarize the major points in their own terms. Recitation of the original text is unacceptable. This is why every module contains an "Outline and reflections" question as well as a "Foundational concepts" question in the Conceptual reasoning section, to prompt reflective reading.
- No assigned question is deemed answered unless and until the student demonstrates their ability to consistently and correctly apply the concepts to *variations* of that question. This is why module questions typically contain multiple "Challenges" suggesting different applications of the concept(s) as well as variations on the same theme(s). Instructors are encouraged to devise as many of their own "Challenges" as they are able, in order to have a multitude of ways ready to probe students' understanding.
- No assigned experiment or project is deemed complete unless and until the student demonstrates the task in action. If this cannot be done "live" before the instructor, video-recordings showing the demonstration are acceptable. All relevant safety precautions must be followed, all test equipment must be used correctly, and the student must be able to properly explain all results. The student must also successfully answer all Challenges presented by the instructor for that experiment or project.

Students learning from these modules would do well to abide by the following principles:

- No text should be considered fully and adequately read unless and until you can express every idea *in your own words, using your own examples*.
- You should always articulate your thoughts as you read the text, noting points of agreement, confusion, and epiphanies. Feel free to print the text on paper and then write your notes in the margins. Alternatively, keep a journal for your own reflections as you read. This is truly a helpful tool when digesting complicated concepts.
- Never take the easy path of highlighting or underlining important text. Instead, *summarize* and/or *comment* on the text using your own words. This actively engages your mind, allowing you to more clearly perceive points of confusion or misunderstanding on your own.
- A very helpful strategy when learning new concepts is to place yourself in the role of a teacher, if only as a mental exercise. Either explain what you have recently learned to someone else, or at least *imagine* yourself explaining what you have learned to someone else. The simple act of having to articulate new knowledge and skill forces you to take on a different perspective, and will help reveal weaknesses in your understanding.
- Perform each and every mathematical calculation and thought experiment shown in the text on your own, referring back to the text to see that your results agree. This may seem trivial and unnecessary, but it is critically important to ensuring you actually understand what is presented, especially when the concepts at hand are complicated and easy to misunderstand. Apply this same strategy to become proficient in the use of *circuit simulation software*, checking to see if your simulated results agree with the results shown in the text.
- Above all, recognize that learning is hard work, and that a certain level of frustration is unavoidable. There are times when you will struggle to grasp some of these concepts, and that struggle is a natural thing. Take heart that it will yield with persistent and varied⁴ effort, and never give up!

Students interested in using these modules for self-study will also find them beneficial, although the onus of responsibility for thoroughly reading and answering questions will of course lie with that individual alone. If a qualified instructor is not available to challenge students, a workable alternative is for students to form study groups where they challenge⁵ one another.

To high standards of education,

Tony R. Kuphaldt

⁴As the old saying goes, “Insanity is trying the same thing over and over again, expecting different results.” If you find yourself stumped by something in the text, you should attempt a different approach. Alter the thought experiment, change the mathematical parameters, do whatever you can to see the problem in a slightly different light, and then the solution will often present itself more readily.

⁵Avoid the temptation to simply share answers with study partners, as this is really counter-productive to learning. Always bear in mind that the answer to any question is far less important in the long run than the method(s) used to obtain that answer. The goal of education is to empower one’s life through the improvement of clear and independent thought, literacy, expression, and various practical skills.

Appendix C

Tools used

I am indebted to the developers of many open-source software applications in the creation of these learning modules. The following is a list of these applications with some commentary on each.

You will notice a theme common to many of these applications: a bias toward *code*. Although I am by no means an expert programmer in any computer language, I understand and appreciate the flexibility offered by code-based applications where the user (you) enters commands into a plain ASCII text file, which the software then reads and processes to create the final output. Code-based computer applications are by their very nature *extensible*, while WYSIWYG (What You See Is What You Get) applications are generally limited to whatever user interface the developer makes for you.

The GNU/Linux computer operating system

There is so much to be said about Linus Torvalds' `Linux` and Richard Stallman's `GNU` project. First, to credit just these two individuals is to fail to do justice to the *mob* of passionate volunteers who contributed to make this amazing software a reality. I first learned of `Linux` back in 1996, and have been using this operating system on my personal computers almost exclusively since then. It is *free*, it is completely *configurable*, and it permits the continued use of highly efficient `Unix` applications and scripting languages (e.g. shell scripts, Makefiles, `sed`, `awk`) developed over many decades. `Linux` not only provided me with a powerful computing platform, but its open design served to inspire my life's work of creating open-source educational resources.

Bram Moolenaar's Vim text editor

Writing code for any code-based computer application requires a *text editor*, which may be thought of as a word processor strictly limited to outputting plain-ASCII text files. Many good text editors exist, and one's choice of text editor seems to be a deeply personal matter within the programming world. I prefer `Vim` because it operates very similarly to `vi` which is ubiquitous on `Unix/Linux` operating systems, and because it may be entirely operated via keyboard (i.e. no mouse required) which makes it fast to use.

Donald Knuth's \TeX typesetting system

Developed in the late 1970's and early 1980's by computer scientist extraordinaire Donald Knuth to typeset his multi-volume magnum opus *The Art of Computer Programming*, this software allows the production of formatted text for screen-viewing or paper printing, all by writing plain-text code to describe how the formatted text is supposed to appear. \TeX is not just a markup language for documents, but it is also a Turing-complete programming language in and of itself, allowing useful algorithms to be created to control the production of documents. Simply put, *\TeX is a programmer's approach to word processing*. Since \TeX is controlled by code written in a plain-text file, this means anyone may read that plain-text file to see exactly how the document was created. This openness afforded by the code-based nature of \TeX makes it relatively easy to learn how other people have created their own \TeX documents. By contrast, examining a beautiful document created in a conventional WYSIWYG word processor such as Microsoft **Word** suggests nothing to the reader about *how* that document was created, or what the user might do to create something similar. As Mr. Knuth himself once quipped, conventional word processing applications should be called WYSIAYG (What You See Is *All* You Get).

Leslie Lamport's \LaTeX extensions to \TeX

Like all true programming languages, \TeX is inherently extensible. So, years after the release of \TeX to the public, Leslie Lamport decided to create a massive extension allowing easier compilation of book-length documents. The result was \LaTeX , which is the markup language used to create all ModEL module documents. You could say that \TeX is to \LaTeX as **C** is to **C++**. This means it is permissible to use any and all \TeX commands within \LaTeX source code, and it all still works. Some of the features offered by \LaTeX that would be challenging to implement in \TeX include automatic index and table-of-content creation.

Tim Edwards' **Xcircuit** drafting program

This wonderful program is what I use to create all the schematic diagrams and illustrations (but not photographic images or mathematical plots) throughout the ModEL project. It natively outputs PostScript format which is a true vector graphic format (this is why the images do not pixellate when you zoom in for a closer view), and it is so simple to use that I have never had to read the manual! Object libraries are easy to create for **Xcircuit**, being plain-text files using PostScript programming conventions. Over the years I have collected a large set of object libraries useful for drawing electrical and electronic schematics, pictorial diagrams, and other technical illustrations.

Gimp graphic image manipulation program

Essentially an open-source clone of Adobe's `PhotoShop`, I use `Gimp` to resize, crop, and convert file formats for all of the photographic images appearing in the `MODEL` modules. Although `Gimp` does offer its own scripting language (called `Script-Fu`), I have never had occasion to use it. Thus, my utilization of `Gimp` to merely crop, resize, and convert graphic images is akin to using a sword to slice bread.

SPICE circuit simulation program

`SPICE` is to circuit analysis as `TEX` is to document creation: it is a form of markup language designed to describe a certain object to be processed in plain-ASCII text. When the plain-text "source file" is compiled by the software, it outputs the final result. More modern circuit analysis tools certainly exist, but I prefer `SPICE` for the following reasons: it is *free*, it is *fast*, it is *reliable*, and it is a fantastic tool for *teaching* students of electricity and electronics how to write simple code. I happen to use rather old versions of `SPICE`, version 2g6 being my "go to" application when I only require text-based output. `NGSPICE` (version 26), which is based on Berkeley `SPICE` version 3f5, is used when I require graphical output for such things as time-domain waveforms and Bode plots. In all `SPICE` example netlists I strive to use coding conventions compatible with all `SPICE` versions.

Andrew D. Hwang's ePiX mathematical visualization programming library

This amazing project is a `C++` library you may link to any `C/C++` code for the purpose of generating PostScript graphic images of mathematical functions. As a completely free and open-source project, it does all the plotting I would otherwise use a Computer Algebra System (CAS) such as `Mathematica` or `Maple` to do. It should be said that `ePiX` is *not* a Computer Algebra System like `Mathematica` or `Maple`, but merely a mathematical *visualization* tool. In other words, it won't determine integrals for you (you'll have to implement that in your own `C/C++` code!), but it can graph the results, and it does so beautifully. What I really admire about `ePiX` is that it is a `C++` programming library, which means it builds on the existing power and toolset available with that programming language. Mr. Hwang could have probably developed his own stand-alone application for mathematical plotting, but by creating a `C++` library to do the same thing he accomplished something much greater.

gnuplot mathematical visualization software

Another open-source tool for mathematical visualization is `gnuplot`. Interestingly, this tool is *not* part of Richard Stallman’s GNU project, its name being a coincidence. For this reason the authors prefer “gnu” *not* be capitalized at all to avoid confusion. This is a much “lighter-weight” alternative to a spreadsheet for plotting tabular data, and the fact that it easily outputs directly to an X11 console or a file in a number of different graphical formats (including PostScript) is very helpful. I typically set my `gnuplot` output format to default (X11 on my Linux PC) for quick viewing while I’m developing a visualization, then switch to PostScript file export once the visual is ready to include in the document(s) I’m writing. As with my use of `Gimp` to do rudimentary image editing, my use of `gnuplot` only scratches the surface of its capabilities, but the important points are that it’s *free* and that it *works well*.

Python programming language

Both Python and C++ find extensive use in these modules as instructional aids and exercises, but I’m listing Python here as a *tool* for myself because I use it almost daily as a *calculator*. If you open a Python interpreter console and type `from math import *` you can type mathematical expressions and have it return results just as you would on a hand calculator. Complex-number (i.e. *phasor*) arithmetic is similarly supported if you include the complex-math library (`from cmath import *`). Examples of this are shown in the Programming References chapter (if included) in each module. Of course, being a fully-featured programming language, Python also supports conditionals, loops, and other structures useful for calculation of quantities. Also, running in a console environment where all entries and returned values show as text in a chronologically-ordered list makes it easy to copy-and-paste those calculations to document exactly how they were performed.

Appendix D

Creative Commons License

Creative Commons Attribution 4.0 International Public License

By exercising the Licensed Rights (defined below), You accept and agree to be bound by the terms and conditions of this Creative Commons Attribution 4.0 International Public License (“Public License”). To the extent this Public License may be interpreted as a contract, You are granted the Licensed Rights in consideration of Your acceptance of these terms and conditions, and the Licensor grants You such rights in consideration of benefits the Licensor receives from making the Licensed Material available under these terms and conditions.

Section 1 – Definitions.

a. **Adapted Material** means material subject to Copyright and Similar Rights that is derived from or based upon the Licensed Material and in which the Licensed Material is translated, altered, arranged, transformed, or otherwise modified in a manner requiring permission under the Copyright and Similar Rights held by the Licensor. For purposes of this Public License, where the Licensed Material is a musical work, performance, or sound recording, Adapted Material is always produced where the Licensed Material is synched in timed relation with a moving image.

b. **Adapter’s License** means the license You apply to Your Copyright and Similar Rights in Your contributions to Adapted Material in accordance with the terms and conditions of this Public License.

c. **Copyright and Similar Rights** means copyright and/or similar rights closely related to copyright including, without limitation, performance, broadcast, sound recording, and Sui Generis Database Rights, without regard to how the rights are labeled or categorized. For purposes of this Public License, the rights specified in Section 2(b)(1)-(2) are not Copyright and Similar Rights.

d. **Effective Technological Measures** means those measures that, in the absence of proper authority, may not be circumvented under laws fulfilling obligations under Article 11 of the WIPO Copyright Treaty adopted on December 20, 1996, and/or similar international agreements.

e. **Exceptions and Limitations** means fair use, fair dealing, and/or any other exception or

limitation to Copyright and Similar Rights that applies to Your use of the Licensed Material.

f. **Licensed Material** means the artistic or literary work, database, or other material to which the Licensor applied this Public License.

g. **Licensed Rights** means the rights granted to You subject to the terms and conditions of this Public License, which are limited to all Copyright and Similar Rights that apply to Your use of the Licensed Material and that the Licensor has authority to license.

h. **Licensor** means the individual(s) or entity(ies) granting rights under this Public License.

i. **Share** means to provide material to the public by any means or process that requires permission under the Licensed Rights, such as reproduction, public display, public performance, distribution, dissemination, communication, or importation, and to make material available to the public including in ways that members of the public may access the material from a place and at a time individually chosen by them.

j. **Sui Generis Database Rights** means rights other than copyright resulting from Directive 96/9/EC of the European Parliament and of the Council of 11 March 1996 on the legal protection of databases, as amended and/or succeeded, as well as other essentially equivalent rights anywhere in the world.

k. **You** means the individual or entity exercising the Licensed Rights under this Public License. **Your** has a corresponding meaning.

Section 2 – Scope.

a. License grant.

1. Subject to the terms and conditions of this Public License, the Licensor hereby grants You a worldwide, royalty-free, non-sublicensable, non-exclusive, irrevocable license to exercise the Licensed Rights in the Licensed Material to:

A. reproduce and Share the Licensed Material, in whole or in part; and

B. produce, reproduce, and Share Adapted Material.

2. Exceptions and Limitations. For the avoidance of doubt, where Exceptions and Limitations apply to Your use, this Public License does not apply, and You do not need to comply with its terms and conditions.

3. Term. The term of this Public License is specified in Section 6(a).

4. Media and formats; technical modifications allowed. The Licensor authorizes You to exercise the Licensed Rights in all media and formats whether now known or hereafter created, and to make technical modifications necessary to do so. The Licensor waives and/or agrees not to assert any right or authority to forbid You from making technical modifications necessary to exercise the Licensed Rights, including technical modifications necessary to circumvent Effective Technological Measures.

For purposes of this Public License, simply making modifications authorized by this Section 2(a)(4) never produces Adapted Material.

5. Downstream recipients.

A. Offer from the Licensor – Licensed Material. Every recipient of the Licensed Material automatically receives an offer from the Licensor to exercise the Licensed Rights under the terms and conditions of this Public License.

B. No downstream restrictions. You may not offer or impose any additional or different terms or conditions on, or apply any Effective Technological Measures to, the Licensed Material if doing so restricts exercise of the Licensed Rights by any recipient of the Licensed Material.

6. No endorsement. Nothing in this Public License constitutes or may be construed as permission to assert or imply that You are, or that Your use of the Licensed Material is, connected with, or sponsored, endorsed, or granted official status by, the Licensor or others designated to receive attribution as provided in Section 3(a)(1)(A)(i).

b. Other rights.

1. Moral rights, such as the right of integrity, are not licensed under this Public License, nor are publicity, privacy, and/or other similar personality rights; however, to the extent possible, the Licensor waives and/or agrees not to assert any such rights held by the Licensor to the limited extent necessary to allow You to exercise the Licensed Rights, but not otherwise.

2. Patent and trademark rights are not licensed under this Public License.

3. To the extent possible, the Licensor waives any right to collect royalties from You for the exercise of the Licensed Rights, whether directly or through a collecting society under any voluntary or waivable statutory or compulsory licensing scheme. In all other cases the Licensor expressly reserves any right to collect such royalties.

Section 3 – License Conditions.

Your exercise of the Licensed Rights is expressly made subject to the following conditions.

a. Attribution.

1. If You Share the Licensed Material (including in modified form), You must:

A. retain the following if it is supplied by the Licensor with the Licensed Material:

i. identification of the creator(s) of the Licensed Material and any others designated to receive attribution, in any reasonable manner requested by the Licensor (including by pseudonym if designated);

ii. a copyright notice;

- iii. a notice that refers to this Public License;
- iv. a notice that refers to the disclaimer of warranties;
- v. a URI or hyperlink to the Licensed Material to the extent reasonably practicable;

B. indicate if You modified the Licensed Material and retain an indication of any previous modifications; and

C. indicate the Licensed Material is licensed under this Public License, and include the text of, or the URI or hyperlink to, this Public License.

2. You may satisfy the conditions in Section 3(a)(1) in any reasonable manner based on the medium, means, and context in which You Share the Licensed Material. For example, it may be reasonable to satisfy the conditions by providing a URI or hyperlink to a resource that includes the required information.

3. If requested by the Licensor, You must remove any of the information required by Section 3(a)(1)(A) to the extent reasonably practicable.

4. If You Share Adapted Material You produce, the Adapter's License You apply must not prevent recipients of the Adapted Material from complying with this Public License.

Section 4 – Sui Generis Database Rights.

Where the Licensed Rights include Sui Generis Database Rights that apply to Your use of the Licensed Material:

- a. for the avoidance of doubt, Section 2(a)(1) grants You the right to extract, reuse, reproduce, and Share all or a substantial portion of the contents of the database;
- b. if You include all or a substantial portion of the database contents in a database in which You have Sui Generis Database Rights, then the database in which You have Sui Generis Database Rights (but not its individual contents) is Adapted Material; and
- c. You must comply with the conditions in Section 3(a) if You Share all or a substantial portion of the contents of the database.

For the avoidance of doubt, this Section 4 supplements and does not replace Your obligations under this Public License where the Licensed Rights include other Copyright and Similar Rights.

Section 5 – Disclaimer of Warranties and Limitation of Liability.

a. Unless otherwise separately undertaken by the Licensor, to the extent possible, the Licensor offers the Licensed Material as-is and as-available, and makes no representations or warranties of any kind concerning the Licensed Material, whether express, implied, statutory, or other. This includes, without limitation, warranties of title, merchantability, fitness for a particular purpose, non-infringement, absence of latent or other defects, accuracy, or the presence or absence of errors,

whether or not known or discoverable. Where disclaimers of warranties are not allowed in full or in part, this disclaimer may not apply to You.

b. To the extent possible, in no event will the Licensor be liable to You on any legal theory (including, without limitation, negligence) or otherwise for any direct, special, indirect, incidental, consequential, punitive, exemplary, or other losses, costs, expenses, or damages arising out of this Public License or use of the Licensed Material, even if the Licensor has been advised of the possibility of such losses, costs, expenses, or damages. Where a limitation of liability is not allowed in full or in part, this limitation may not apply to You.

c. The disclaimer of warranties and limitation of liability provided above shall be interpreted in a manner that, to the extent possible, most closely approximates an absolute disclaimer and waiver of all liability.

Section 6 – Term and Termination.

a. This Public License applies for the term of the Copyright and Similar Rights licensed here. However, if You fail to comply with this Public License, then Your rights under this Public License terminate automatically.

b. Where Your right to use the Licensed Material has terminated under Section 6(a), it reinstates:

1. automatically as of the date the violation is cured, provided it is cured within 30 days of Your discovery of the violation; or

2. upon express reinstatement by the Licensor.

For the avoidance of doubt, this Section 6(b) does not affect any right the Licensor may have to seek remedies for Your violations of this Public License.

c. For the avoidance of doubt, the Licensor may also offer the Licensed Material under separate terms or conditions or stop distributing the Licensed Material at any time; however, doing so will not terminate this Public License.

d. Sections 1, 5, 6, 7, and 8 survive termination of this Public License.

Section 7 – Other Terms and Conditions.

a. The Licensor shall not be bound by any additional or different terms or conditions communicated by You unless expressly agreed.

b. Any arrangements, understandings, or agreements regarding the Licensed Material not stated herein are separate from and independent of the terms and conditions of this Public License.

Section 8 – Interpretation.

a. For the avoidance of doubt, this Public License does not, and shall not be interpreted to, reduce, limit, restrict, or impose conditions on any use of the Licensed Material that could lawfully

be made without permission under this Public License.

b. To the extent possible, if any provision of this Public License is deemed unenforceable, it shall be automatically reformed to the minimum extent necessary to make it enforceable. If the provision cannot be reformed, it shall be severed from this Public License without affecting the enforceability of the remaining terms and conditions.

c. No term or condition of this Public License will be waived and no failure to comply consented to unless expressly agreed to by the Licensor.

d. Nothing in this Public License constitutes or may be interpreted as a limitation upon, or waiver of, any privileges and immunities that apply to the Licensor or You, including from the legal processes of any jurisdiction or authority.

Creative Commons is not a party to its public licenses. Notwithstanding, Creative Commons may elect to apply one of its public licenses to material it publishes and in those instances will be considered the “Licensor.” Except for the limited purpose of indicating that material is shared under a Creative Commons public license or as otherwise permitted by the Creative Commons policies published at creativecommons.org/policies, Creative Commons does not authorize the use of the trademark “Creative Commons” or any other trademark or logo of Creative Commons without its prior written consent including, without limitation, in connection with any unauthorized modifications to any of its public licenses or any other arrangements, understandings, or agreements concerning use of licensed material. For the avoidance of doubt, this paragraph does not form part of the public licenses.

Creative Commons may be contacted at creativecommons.org.

Appendix E

References

“Navy Electricity and Electronics Training Series – Module 8 – Introduction to Amplifiers”, NAVSUP Logistics Tracking Number 0504-LP-026-8330, prepared by AVCM Keith E. Glading, Naval Education and Training Professional Development and Technology Center, 1998.

Self, Douglas, *Audio Power Amplifier Design Handbook*, Fourth edition, Elsevier (Newnes), Oxford, England, 2006.

“Transistor Module QCA100A/QBB100A40/60” datasheet, SanRex, Port Washington, NY.

Appendix F

Version history

This is a list showing all significant additions, corrections, and other edits made to this learning module. Each entry is referenced by calendar date in reverse chronological order (newest version first), which appears on the front cover of every learning module for easy reference. Any contributors to this open-source document are listed here as well.

18 February 2025 – added an animation section showing a BJT turning on. Also, improved the existing crossover distortion animation by including two of the last frames that I had omitted for some reason. Also added some Challenge questions.

13 February 2025 – added another amplifier circuit to the “Identifying component functions” Conceptual Reasoning question, using Jessica Smith’s audio amplifier schematic diagram as the basis.

17 September 2024 – divided the Introduction chapter into sections, one with recommendations for students, one with a listing of challenging concepts, and one with recommendations for instructors. Also added a footnote on current mirrors prior to the section in which they are thoroughly discussed.

15 February 2024 – typo correction.

13 October 2023 – added two more styles of current mirror circuits (including the Wilson current mirror) to that section of the Tutorial.

25-26 September 2023 – minor edits to the Tutorial regarding push-pull amplification, including a new discussion on output impedance throughout the signal’s state. Also added new Introduction chapter questions regarding even- versus odd-numbered harmonic distortion typical of single-ended versus push-pull amplifier topologies, respectively. Also added some instructor notes to the questions. Also added a new Case Tutorial section showing a detailed quantitative analysis of a current mirror circuit.

19 September 2023 – added a Case Tutorial section showing a simple class-B push-pull power amplifier, and also added a Tutorial section on audio power amplifier topology.

15-16 September 2023 – edited image_3299 and added more commentary on push-pull amplifier biasing. Also edited some of the text for a clearer presentation. Also added some discussion to the push-pull Tutorial section on class G operation.

19 May 2023 – added a Diagnostic Reasoning question based on a C-language simulation of a common-emitter amplifier, showing clipping at high input signal magnitudes.

28 November 2022 – placed questions at the top of the itemized list in the Introduction chapter prompting students to devise experiments related to the tutorial content.

3 October 2022 – changed a pair of quotation marks to make them proper.

24 February 2022 – added a new Case Tutorial section, showing the loading effect of one amplifier stage on another.

22 February 2022 – added some questions to the Introduction chapter, and added some more explanatory text and illustrations to the Tutorial on differential pairs.

17 February 2022 – minor edits to the Tutorial chapter on class AB operation, and additions to the Introduction chapter.

11 December 2021 – added a Case Tutorial chapter with a section showing a three-stage BJT amplifier using negative feedback for precise gain.

28 September 2021 – added new content on push-pull BJT amplifier with split DC power supply, and made other minor edits including adding questions about Foundational Concepts to the “Current mirror calculations” Quantitative Reasoning question.

5 September 2021 – added a new section to the Tutorial on current mirrors, added a Conceptual Reasoning question (copied from the Operational Amplifiers module) on qualitative analysis of an LM324 opamp, and added a Quantitative Reasoning question (copied from the Linear Current Regulators module) on current mirror calculations.

10 May 2021 – commented out or deleted empty chapters.

26 March 2021 – added photograph of a Darlington pair power transistor module to the Tutorial.

18 March 2021 – corrected one instance of “volts” that should have been capitalized “Volts”.

30 November 2020 – significantly edited the Introduction chapter to make it more suitable as a pre-study guide and to provide cues useful to instructors leading “inverted” teaching sessions.

25 November 2020 – corrected typographical error in the push-pull transistor stage diagram, where I erroneously had the output coupling capacitor acting as a load in both half-cycles.

9 May 2020 – corrected conceptual error regarding push-pull amplifier stages. The transformer-coupled type is actually common-emitter rather than common-collector and as such is capable of voltage gains greater than 1.

29 April 2020 – added new Conceptual Reasoning problems using TTL logic gates as practice for qualitative analysis of multi-transistor BJT amplifiers.

26-27 March 2020 – completed writing Tutorial.

28 February 2020 – changed the name of this module from “Multi-Stage Amplifiers” to “Multi-Transistor Amplifiers”. Also wrote the Introduction, and began writing content for the Tutorial chapter.

27 February 2020 – continued adding problems.

15 February 2020 – continued adding problems.

14 February 2020 – document first created.

Index

- 741 operational amplifier, 52
- Adding quantities to a qualitative problem, 146
- Annotating diagrams, 145
- Black, Harold, 16
- Capacitive coupling, 27
- Capacitive reactance, 27
- Cascode, 29
- Checking for exceptions, 146
- Checking your work, 146
- Class A amplification, 30, 36, 46
- Class AB amplification, 18, 34, 36
- Class B amplification, 32, 36
- Class G amplification, 36
- Clipping, 19
- Code, computer, 153
- Common-base, 39
- Common-collector, 39
- Common-emitter, 39
- Comparator, 40
- Compensation, high-frequency, 54
- Coupling, 26
- Current mirror, 34, 41
- Current mirror, Wilson, 45
- Darlington pair, 23
- Differential pair, 38
- Dimensional analysis, 145
- Diode equation, 9, 41
- Direct coupling, 26
- Edwards, Tim, 154
- Electric guitar, 19
- Electromagnetic induction, 27
- Error, static, 45
- Feedback, negative, 15
- Graph values to solve a problem, 146
- Greenleaf, Cynthia, 95
- Guitar, electric, 19
- How to teach with these modules, 148
- Hwang, Andrew D., 155
- IC, 42
- Identify given data, 145
- Identify relevant principles, 145
- Induction, electromagnetic, 27
- Instructions for projects and experiments, 149
- Integrated circuit, 42
- Intermediate results, 145
- Inverted instruction, 148
- Inverting amplifier, 22, 26, 28
- Kirchhoff's Current Law, 45, 50
- Kirchhoff's Voltage Law, 24, 39
- Knuth, Donald, 154
- Lampert, Leslie, 154
- Limiting cases, 146
- Metacognition, 100
- Moolenaar, Bram, 153
- Murphy, Lynn, 95
- Negative feedback, 15, 29, 40, 54
- Non-inverting amplifier, 22, 26, 28
- Ohm's Law, 34, 47
- Opamp, 16
- Open-source, 153
- Operational amplifier, 16, 40
- Operational amplifier, model 741, 52

- Oscilloscope, 31
- Overdrive, electric guitar, 19

- Phase splitter, 35
- Problem-solving: annotate diagrams, 145
- Problem-solving: check for exceptions, 146
- Problem-solving: checking work, 146
- Problem-solving: dimensional analysis, 145
- Problem-solving: graph values, 146
- Problem-solving: identify given data, 145
- Problem-solving: identify relevant principles, 145
- Problem-solving: interpret intermediate results, 145
- Problem-solving: limiting cases, 146
- Problem-solving: qualitative to quantitative, 146
- Problem-solving: quantitative to qualitative, 146
- Problem-solving: reductio ad absurdum, 146
- Problem-solving: simplify the system, 145
- Problem-solving: thought experiment, 5, 39, 47, 145
- Problem-solving: track units of measurement, 145
- Problem-solving: visually represent the system, 145
- Problem-solving: work in reverse, 146

- Qualitatively approaching a quantitative problem, 146

- Rail, power supply, 32, 40
- Reactance, capacitive, 27
- Reading Apprenticeship, 95
- Reductio ad absurdum, 146–148

- Saturation, BJT, 24
- Schoenbach, Ruth, 95
- Scientific method, 100
- Shockley diode equation, 9, 41
- Shockley, William, 41
- Simplifying a system, 145
- Sinking current, 31
- Socrates, 147
- Socratic dialogue, 148
- Sourcing current, 31
- Spectrum analyzer, 31
- SPICE, 95

- Split power supply, 32
- Stallman, Richard, 153
- Static error, current mirror, 45
- Sziklai pair, 23

- Thought experiment, 5, 39, 47, 145
- Topology, 53
- Torvalds, Linus, 153
- Transformer coupling, 27

- Units of measurement, 145

- Visualizing a system, 145

- Wilson current mirror, 45
- Wilson, George R., 45
- Work in reverse to solve a problem, 146
- WYSIWYG, 153, 154