

# MODULAR ELECTRONICS LEARNING (MODEL) PROJECT



## VARIABLE FREQUENCY AC MOTOR DRIVES

© 2018-2025 BY TONY R. KUPHALDT – UNDER THE TERMS AND CONDITIONS OF THE  
CREATIVE COMMONS ATTRIBUTION 4.0 INTERNATIONAL PUBLIC LICENSE

LAST UPDATE = 25 APRIL 2025

This is a copyrighted work, but licensed under the Creative Commons Attribution 4.0 International Public License. A copy of this license is found in the last Appendix of this document. Alternatively, you may visit <http://creativecommons.org/licenses/by/4.0/> or send a letter to Creative Commons: 171 Second Street, Suite 300, San Francisco, California, 94105, USA. The terms and conditions of this license allow for free copying, distribution, and/or modification of all licensed works by the general public.



# Contents

<b>1</b>	<b>Introduction</b>	<b>3</b>
1.1	Recommendations for students . . . . .	3
1.2	Challenging concepts related to variable-frequency motor drives . . . . .	5
1.3	Recommendations for instructors . . . . .	6
<b>2</b>	<b>Case Tutorial</b>	<b>7</b>
2.1	Example: demonstrating DC injection braking . . . . .	8
<b>3</b>	<b>Tutorial</b>	<b>9</b>
3.1	Basic VFD function . . . . .	11
3.2	AC motor braking . . . . .	14
3.2.1	DC injection braking . . . . .	15
3.2.2	Dynamic braking . . . . .	16
3.2.3	Regenerative braking . . . . .	18
3.2.4	Plugging . . . . .	20
3.3	Important VFD parameters . . . . .	21
3.3.1	Maximum and minimum speed (frequency) . . . . .	22
3.3.2	Acceleration and Deceleration time . . . . .	22
3.3.3	Stopping method . . . . .	22
3.3.4	Volts per Hertz profile . . . . .	23
3.3.5	PWM frequency . . . . .	24
3.3.6	Current limiting . . . . .	25
3.3.7	Start/stop source . . . . .	25
3.3.8	Speed reference source . . . . .	25
3.3.9	Skip frequency . . . . .	26
3.3.10	Fault recovery . . . . .	26
3.4	Line reactors . . . . .	27
<b>4</b>	<b>Derivations and Technical References</b>	<b>31</b>
4.1	Electrical safety . . . . .	32
<b>5</b>	<b>Animations</b>	<b>41</b>
5.1	Rotating magnetic field animated . . . . .	42
5.2	VFD transistor switching sequence . . . . .	67

<b>6 Questions</b>	<b>95</b>
6.1 Conceptual reasoning . . . . .	99
6.1.1 Reading outline and reflections . . . . .	100
6.1.2 Foundational concepts . . . . .	101
6.1.3 Start-stop-speed-direction control . . . . .	104
6.1.4 VFD/pump configuration . . . . .	105
6.1.5 Rockwell PowerFlex 4 configuration . . . . .	107
6.1.6 Currents within a VFD circuit . . . . .	108
6.1.7 Transistor states . . . . .	110
6.1.8 Grinding machine braking . . . . .	111
6.2 Quantitative reasoning . . . . .	112
6.2.1 Miscellaneous physical constants . . . . .	113
6.2.2 Introduction to spreadsheets . . . . .	114
6.2.3 Three-phase simulation program . . . . .	117
6.2.4 Line reactor harmonic impedance . . . . .	119
6.2.5 Line reactor resonance . . . . .	121
6.2.6 Limited-adjustment speed potentiometer . . . . .	122
6.3 Diagnostic reasoning . . . . .	123
6.3.1 Predicting effects of VFD component faults . . . . .	123
<b>7 Projects and Experiments</b>	<b>125</b>
7.1 Recommended practices . . . . .	125
7.1.1 Safety first! . . . . .	126
7.1.2 Other helpful tips . . . . .	128
7.1.3 Terminal blocks for circuit construction . . . . .	129
7.1.4 Conducting experiments . . . . .	132
7.1.5 Constructing projects . . . . .	136
7.2 Experiment: DC injection braking . . . . .	137
7.3 Experiment: AC motor starter with DC injection braking . . . . .	138
7.4 Project: VFD-controlled AC induction motor . . . . .	139
<b>A Problem-Solving Strategies</b>	<b>141</b>
<b>B Instructional philosophy</b>	<b>143</b>
<b>C Tools used</b>	<b>149</b>
<b>D Creative Commons License</b>	<b>153</b>
<b>E References</b>	<b>161</b>
<b>F Version history</b>	<b>163</b>
<b>Index</b>	<b>164</b>



# Chapter 1

## Introduction

### 1.1 Recommendations for students

Induction AC motors are simple, rugged, and efficient machines. For many years the major objection to their use in some applications was the inability to control their speed, being a function of stator poles and line power frequency, neither of which may be easily varied. The advent of reliable power electronics, however, made possible the design and construction of inverter circuits for the express purpose of providing variable-frequency AC power to three-phase induction motors for their speed control. These inverters are generally called *variable frequency drives*, or *VFDs*.

VFDs are very popular for industrial motor control, as they permit extremely the efficient use of electrical power for motors. No longer must an induction motor spin at the same speed all the time – with a VFD connected that same motor may be slowed down at will to minimize energy consumption and/or to achieve a different production rate for whatever machine or process is being driven by that motor.

Important concepts related to VFDs include **rectification**, **filtering**, **pulse-width modulation**, **AC inductor motor theory**, **reactance**, **V/F ratio**, electrical **noise**, **fundamental** and **harmonic** frequencies, **Conservation of Energy**, **transistors**, **DC-AC conversion**, motor **base parameters**, **resonance**, , , and .

Here are some good questions to ask of yourself while studying this subject:

- How might an experiment be designed and conducted to explore the concept of energy conservation in a VFD-controlled motor system with braking capability? What hypothesis (i.e. prediction) might you pose for that experiment, and what result(s) would either support or disprove that hypothesis?
- How might an experiment be designed and conducted to explore harmonic mitigation strategies in a VFD-controlled motor system? What hypothesis (i.e. prediction) might you pose for that experiment, and what result(s) would either support or disprove that hypothesis?
- What are some practical applications of VFDs?
- How is the speed of an AC induction motor best controlled?

- What is the basic operating principle of an AC induction motor?
- What is the “slip speed” of an AC induction motor?
- What are the three basic sections of a VFD circuit, and the function each one performs?
- Why are the transistors of a VFD rapidly pulsed on and off rather than operated in their linear regions?
- How exactly do VFDs create harmonic frequencies?
- What is a “triplen” harmonic?
- In what ways are harmonics potentially bad for electrical power networks?
- How may the bad effects of harmonics be reduced in an electrical power network?
- What are the various ways in which a VFD may act to turn the motor into a brake?
- Where does the kinetic energy of a spinning motor go when a VFD brakes that motor?
- What benefit(s) do reactors offer to VFD-controlled motor circuits other than harmonic mitigation?
- What are “base parameters” for a VFD and why are they important?
- What is a *reflected* signal along a cable, and what causes this phenomenon to happen?

## 1.2 Challenging concepts related to variable-frequency motor drives

The following list cites concepts related to this module's topic that are easily misunderstood, along with suggestions for properly understanding them:

- **Motor inrush current** – the fact that all electric motors draw more current when starting to turn than they do when turning at full speed is often misinterpreted as a time-delay effect caused by the motor's inherent winding inductance. This is not true, and in fact if it were it would mean the motor would draw *less* current upon power-up and *more* current after some time had passed. The real explanation is rooted in the phenomenon of *counter-EMF* which occurs as the motor shaft begins to spin. Since counter-EMF is a speed-based phenomenon it means that inrush current can and will continue unabated if the motor shaft is not mechanically permitted to turn!



### 1.3 Recommendations for instructors

This section lists realistic student learning outcomes supported by the content of the module as well as suggested means of assessing (measuring) student learning. The outcomes state what learners should be able to do, and the assessments are specific challenges to prove students have learned.

- **Outcome** – Demonstrate effective technical reading and writing

Assessment – Students present their outlines of this module’s instructional chapters (e.g. Case Tutorial, Tutorial, Historical References, etc.) ideally as an entry to a larger Journal document chronicling their learning. These outlines should exhibit good-faith effort at summarizing major concepts explained in the text.

Assessment – Students show how quantitative results were obtained by the author in the Tutorial chapter’s examples.

- **Outcome** – Apply foundational circuit concepts to the analysis of VFD circuits

Assessment – Trace currents through a three-phase H-bridge circuit and three-phase bridge rectifier within a VFD at specified points in the three-phase waveforms; e.g. pose problems in the form of the “Currents within a VFD circuit” Conceptual Reasoning question.

Assessment – Identify transistor states in a three-phase H-bridge circuit within a VFD at specified points in the three-phase waveforms; e.g. pose problems in the form of the “Transistor states” Conceptual Reasoning question.

- **Outcome** – Independent research

Assessment – Locate VFD datasheets and properly interpret some of the information contained in those documents including PWM frequency range, horsepower rating, braking methods, regenerative braking option, etc.

## Chapter 2

# Case Tutorial

The idea behind a *Case Tutorial* is to explore new concepts by way of example. In this chapter you will read less presentation of theory compared to other Tutorial chapters, but by close observation and comparison of the given examples be able to discern patterns and principles much the same way as a scientific experimenter. Hopefully you will find these cases illuminating, and a good supplement to text-based tutorials.

These examples also serve well as challenges following your reading of the other Tutorial(s) in this module – can you explain *why* the circuits behave as they do?

## 2.1 Example: demonstrating DC injection braking

An easy demonstration of DC injection motor braking may be performed using commonly-available components: a small AC induction motor (such as the type used in residential bathroom ventilation fans, typically sold as replacement motors at most hardware stores) and a 6 Volt dry-cell battery.

Spin the motor's shaft and feel how freely it turns. Then, connect the 6 Volt battery to the motor's terminals and try spinning the shaft again – you will notice the shaft does not spin as easily as it did before, due to the effect of Lenz's Law as the conductive rotor rotates within the stationary magnetic field produced by the stator winding energized by the (DC) battery. The currents induce in the spinning rotor produce magnetic fields that oppose its motion, making the rotor feel as though there is some sort of friction working against its motion.

The analogy to mechanical friction is quite appropriate, as the work done by turning the motor's shaft becomes converted into heat inside the rotor, not unlike how a mechanical friction brake would convert work into heat.

## Chapter 3

# Tutorial

AC induction motors are based on the principle of a *rotating magnetic field* produced by a set of stationary windings (called *stator* windings) energized by AC power of different phases. The effect is not unlike a series of blinking “chaser” light bulbs which appear to “move” in one direction due to the blinking sequence. If sets of wire coils (windings) are energized in a like manner – each coil reaching its peak field strength at a different time from its adjacent neighbor – the effect will be a magnetic field that “appears” to move in one direction. If these windings are oriented around the circumference of a circle, the moving magnetic field rotates about the center of the circle. Refer to section 5.1 beginning on page 42 to view a flip-book animation showing how a set of three-phase stator windings create a rotating magnetic field vector.

Any magnetized object placed in the center of this circle will attempt to spin at the same rotational speed as the rotating magnetic field. *Synchronous* AC motors use this principle, where a magnetized rotor follows the magnetic field’s speed in precise lock-step.

Any electrically conductive object placed in the center of the circle will experience *induction* as the magnetic field direction changes around the conductor. This will induce electric currents within the conductive object, which in turn will react against the rotating magnetic field in such a way that the object will be “dragged along” by the field, always lagging a bit in speed. *Induction* AC motors use this principle, where a non-magnetized (but electrically conductive) rotor rotates at a speed slightly less than the synchronous speed of the rotating magnetic field. The difference between the synchronous speed of the rotating magnetic field and the rotor’s actual speed is called *slip speed*, and the amount of torque<sup>1</sup> (i.e. twisting force) generated by the motor’s rotor is a function of this slip speed.

---

<sup>1</sup>To those unfamiliar with the term, *torque* is the rotational equivalent of *force*. Whereas force is expressed in the metric unit of Newtons, torque is expressed in the compound metric unit of Newton-meters, one Newton-meter being the torque (i.e. twisting force) generated by a one-Newton linear force applied perpendicularly to the end of a handle one meter in length from the center of rotation.

The rotational speed of this magnetic field is directly proportional to the frequency of the AC power, and inversely proportional to the number of poles in the stator:

$$S = \frac{120f}{n}$$

Where,

$S$  = Synchronous speed of rotating magnetic field, in revolutions per minute (RPM)

$f$  = Frequency, in cycles per second (Hz)

$n$  = Total number of stator poles per phase (the simplest possible AC induction motor design will have two poles)

The relationship between synchronous speed, frequency, and pole number may be understood by analogy: the speed at which the lights in a “chaser” light array appear to move is a function of the blinking frequency and the number of light bulbs per unit length. If the number of light bulbs in such an array is doubled by placing additional bulbs between the existing bulbs (so as to maintain the same array length), the apparent speed will be cut in half: with less distance between each pair of bulbs, it takes more cycles (more “blinks”) for the sequence to travel the entire length of the array. Likewise, an AC stator with more poles in its circumference will require more cycles of AC power for the rotating magnetic field to complete one revolution.

A *synchronous* AC motor will spin at the exact same speed as the rotating magnetic field: a practical example is a 4-pole synchronous motor spinning at 1800 RPM with an applied power frequency of 60 Hz. An *induction* AC motor will spin at slightly less than the speed of the magnetic field: a practical example is a 4-pole induction motor spinning at 1720 RPM with an applied power frequency of 60 Hz (i.e. 80 RPM “slip” speed). Induction motors are simpler both in construction and operation, making them the most popular of the two types of AC electric motors in industry.

While the number of poles in the motor’s stator is a quantity fixed<sup>2</sup> at the time of the motor’s manufacture, the frequency of power we apply may be adjusted with the proper electronic circuitry. A high-power circuit designed to produce varying frequencies for an AC motor to run on is called a *variable-frequency drive*, or *VFD*.

---

<sup>2</sup>Multi-speed motors do exist, with selectable pole configurations. An example of this is an electric motor with extra sets of stator windings, which may be connected to form a 4-pole configuration for high speed, and an 8-pole configuration for low speed. If the normal full-load “high” speed for this motor is 1740 RPM, the normal full-load “low” speed will be approximately half that, or 870 RPM. Given a fixed line frequency, this motor will only have these two speeds to choose from.

### 3.1 Basic VFD function

Variable-frequency motor drives are incredibly useful devices, as they allow what would normally be a fixed-speed electric motor to provide useful power over a wide range of speeds. The benefits of variable-speed operation include reduced power consumption (only spinning the motor as fast as it needs to move, and no faster), reduced vibration (less speed = reduced vibrational forces), and the ability to ramp the motor’s speed up and down for reduced wear and tear on mechanical components resulting from acceleration forces.

Another feature common to most VFDs is the ability to actively *brake* the load. This is when the drive causes the motor to actively apply a negative torque to the load to slow it down. Some VFDs even provide means to recover the kinetic energy of the load during the braking process, resulting in further energy savings.

Variable-frequency AC motor drives consist of electronic components to convert the constant-frequency AC input power into variable-frequency (and variable-voltage) AC output power for the motor to run on. This usually takes place in three distinct sections. The *rectifier* section uses diodes to convert line AC power into DC. The *filter* “smooths” the rectified DC power so it has little ripple voltage. Lastly, the *inverter* section re-converts the filtered DC power back into AC, only this time at whatever levels of frequency and voltage is desired to run the motor at different speeds.

A simplified schematic diagram for a VFD is shown here, with a rectifier section on the left (to convert AC input power into DC), a filter capacitor to “smooth” the rectified DC power, and a transistor “bridge” to switch DC into AC at whatever frequency is desired to power the motor<sup>3</sup>. The transistor control circuitry has been omitted from this diagram for the sake of simplicity:

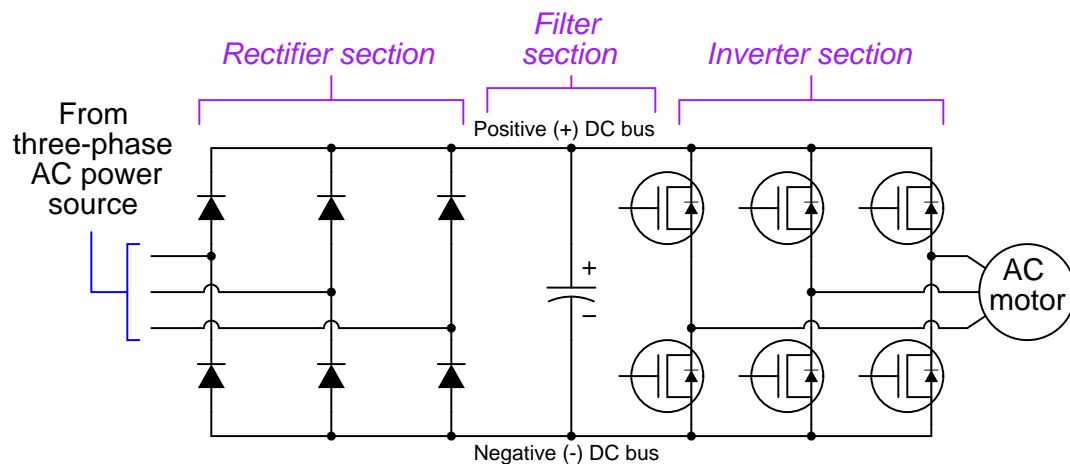

<sup>3</sup>Note the reverse-connected diodes across the source and drain terminals of each power transistor. These diodes serve to protect the transistors against damage from reverse voltage drop, but they also permit the motor to “back feed” power to the DC bus (acting as a *generator*) when the motor’s speed exceeds that of the rotating magnetic field, which may happen when the drive commands the motor to slow down. This leads to interesting possibilities, such as *regenerative braking*, with the addition of some more components.

The six power transistors in the inverter section of the VFD turn on and off in a sequence to create a rotating magnetic field in the AC motor's stator windings, which in turn drags the rotor along with it and causes the motor's shaft to spin. Refer to section 5.2 beginning on page 67 to view a flip-book animation showing the switching sequence of these six transistors and how their respective currents energize the stator windings to create that rotating magnetic flux vector.

In order to synthesize a smooth sine wave, the six power transistors don't just switch on in square-wave fashion at the desired line frequency, but rather pulse on and off many times to simulate the rise and fall of a sinusoidal waveform. The following illustration shows how a continually varying PWM duty cycle is able to synthesize a sinusoidal wave-shape from the DC power provided by the rectifier and filter sections of the VFD:

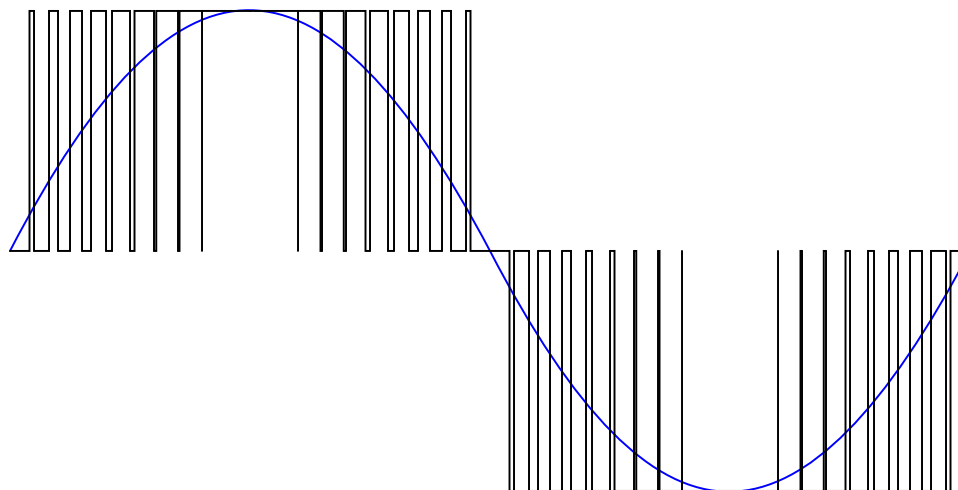

This concept of rapid PWM transistor switching allows the drive to “carve” any arbitrary waveform out of the filtered DC voltage it receives from the rectifier. Virtually any frequency may be synthesized (up to a maximum limited by the frequency of the PWM pulsing), and any voltage (up to a maximum peak established by the DC bus voltage), giving the VFD the ability to power an induction motor over a wide range of speeds.

While frequency control is the key to synchronous and induction AC motor speed control, it is not sufficient on its own. While the speed of an AC motor is a direct function of frequency (controlling how fast the rotating magnetic field rotates around the circumference of the stator), torque is a function of magnetic field strength, which is a function of stator current. Since the stator windings are inductive by nature, their reactance varies with frequency as described by the formula  $X_L = 2\pi fL$ . Thus, as frequency is increased, winding reactance increases along with it. This increase in reactance with increasing frequency would result in decreased stator current if the VFD's output voltage remained constant, leading to torque loss at high speeds and excessive torque (as well as excessive stator heat and magnetic core saturation!) at low speeds. For this reason, the AC voltage output by a VFD is made to vary<sup>4</sup> in proportion to the applied frequency, so that the

<sup>4</sup>The VFD achieves variable output voltage using the same technique used to create variable output frequency:

stator current will remain within good operating limits throughout the speed range of the VFD. This correspondence is called the *voltage-to-frequency ratio*, abbreviated “V/F” ratio or “V/Hz” ratio.

To give an example of a VFD programmed with a constant V/F ratio, if the output line voltage to the motor is 480 Volts RMS at full speed (60 Hz), then the output line voltage should be 240 Volts RMS at half-speed (30 Hz), and 120 Volts RMS at quarter-speed (15 Hz).

Variable-frequency motor drives are manufactured for industrial motor control in a wide range of sizes and horsepower capabilities. Some VFDs are small enough to hold in your hand, while others are large enough to require a freight train for transport. The following photograph shows a pair of moderately-sized Allen-Bradley VFDs (about 100 horsepower each, standing just over 1 meter high), used to control pumps at a wastewater treatment plant:



An important consideration with VFDs is the electrical noise they generate. Square-edged pulse waveforms created by the rapid on-and-off switching of the power transistors are equivalent to infinite series of high-frequency sine waves<sup>5</sup>, some of which may be of high enough frequency to self-propagate through space as electromagnetic waves. This *radio-frequency interference* or *RFI* may be quite severe given the high power levels of industrial motor drive circuits. For this reason, it is *imperative* that neither the motor power conductors nor the conductors feeding AC power to the drive circuit be routed anywhere near small-signal or control wiring, because the induced noise *will* wreak havoc with whatever systems utilize those low-level signals.

RFI noise on the AC power conductors may be mitigated by routing the AC power through *filter* circuits placed near the drive. The filter circuits block high-frequency noise from propagating back to the rest of the AC power distribution wiring where it may influence other electronic equipment. However, there is little that may be done about the RFI noise between the drive and the motor other than to shield the conductors in well-grounded metallic conduit.

---

rapid pulse-width-modulation of the DC bus voltage through the output transistors. When lower output voltage is necessary, the duty cycle of the pulses are reduced throughout the cycle (i.e. transistors are turned on for shorter periods of time) to generate a lower average voltage of the synthesized sine wave.

<sup>5</sup>This equivalence was mathematically proven by Jean Baptiste Joseph Fourier (1768-1830), and is known as a *Fourier series*.



## 3.2 AC motor braking

There are several different methods useful for causing an AC induction motor to *brake*, or slow down:

- DC injection
- Dynamic braking
- Regenerative braking
- Plugging

*DC injection* uses the technique of energizing the stator windings with low-current DC instead of high-current AC as is the case when the motor runs. *Dynamic braking* uses the motor as a generator, dissipating the rotor's kinetic energy through a resistive load. *Regenerative braking* also uses the motor as a generator, but instead of wasting energy in the form of resistive heating, a regenerating motor drive channels the rotor's kinetic energy back into the power supply grid where it may be used by other loads. Lastly, *plugging* works by applying reverse power to the motor, and is the most aggressive means of bringing any motor to a halt.

All electronic motor braking techniques enjoy the advantage of mechanical simplicity. If the motor itself can be used as a brake, then a separate mechanical brake may not be needed. This simplifies the machinery of a system and potentially reduces maintenance costs.

A significant disadvantage of electronic braking techniques is that they all depend on the proper function of the motor drive, and in some cases the AC line power as well. If a VFD's braking ability depends on the presence of AC line power, and that line power suddenly is lost, the VFD will have no braking capacity at all! This means a large motor might suddenly have no ability to brake in the event of a power outage or a tripped circuit breaker, which could be a serious safety issue in some applications. In such cases, one must ensure the presence of other (alternative) braking methods to function in the event of line power failure.

### 3.2.1 DC injection braking

If a spinning AC induction motor's stator coils are energized with DC rather than AC, the rotor will find itself spinning inside a stationary magnetic field. This causes currents to be induced in the rotor bars, which in turn causes a braking force to develop in the rotor in accordance with Lenz's Law. The effect is exactly opposite of what happens when a motor is energized from a stand-still: there, currents are induced in the rotor bars because the rotor is stationary and the stator field is rotating. This method of braking is quite effective, with only small amounts of direct current through the stator winding being necessary to cause a large braking torque.

The braking torque produced by DC injection varies directly with the magnitude of the DC injection current, and also directly with the speed of the rotor. This means the braking force created by DC injection tends to diminish as the motor slows down to a stop.

When any motor acts as a brake, the kinetic energy of the motor and the mechanism it attaches to must go somewhere. This is a basic tenet of physics, codified as the *Law of Energy Conservation*: energy cannot be created or destroyed, only altered in form. When DC injection is used to brake a motor, the braking energy is dissipated in the form of heat by means of the induced currents circulating through the rotor bars and shorting rings. This is something one must be careful to consider when choosing DC injection as a braking method: can the rotor safely dissipate the heat when needed? Repeated braking cycles, especially with little time between cycles, may overheat the rotor and cause damage to the motor.

Modern solid-state AC motor drives easily provide DC injection for braking. All they need to do is energize their output transistors in such a way that one or more of the stator windings sees a constant voltage polarity instead of an alternating polarity as is the case when the motor is running. The following diagram shows the direct current flow into the motor during DC injection, arbitrarily using the mid-upper and left-lower transistors:

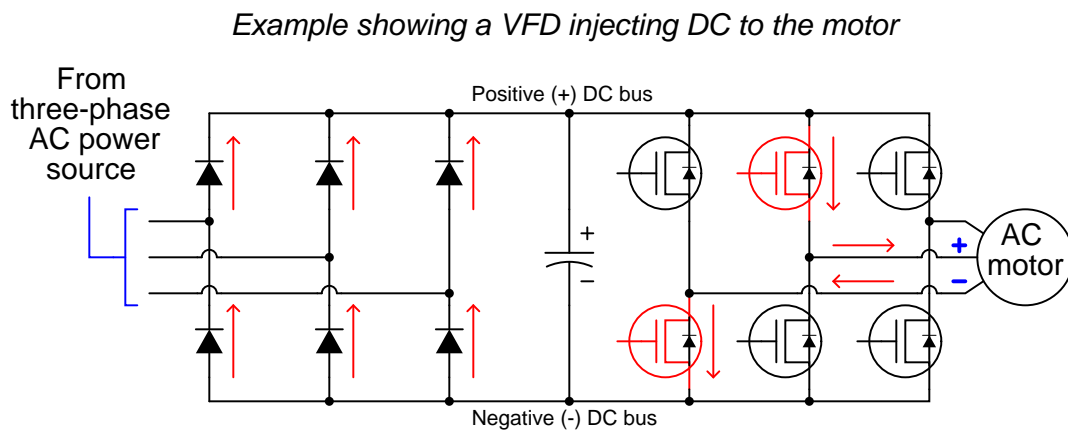

The intensity of the DC injection current may be varied by altering the pulse-width duty cycle of the transistors used to switch the braking current.

### 3.2.2 Dynamic braking

If a powered AC induction motor spins at a speed *faster* than its rotating magnetic field, it acts as a generator: supplying power back to the voltage source, transferring kinetic energy from the spinning rotor and machinery back into electrical power. This makes for an interesting experiment: take an internal combustion engine, steam turbine, water turbine, or some other mechanical prime mover and mechanically *force* a powered induction motor to spin faster than its synchronous speed (i.e. force it to achieve a *negative* slip speed). If a power meter is connected between this motor and the AC line power grid, the meter will register negative power (i.e. power flowing from the motor to the grid, rather than from the grid to the motor).

This principle holds true for an induction motor powered by a VFD as well: if the rotor is spun by some external force faster than the speed of the rotating magnetic field produced by the VFD, it will act as a generator, sending back more power to the VFD than it receives from the VFD. Since the magnetic field's rotational speed is variable – thanks to the VFD's ability to synthesize virtually any desired frequency – it means an induction motor may be made to operate as a generator at almost any speed we desire.

When acting as an electrical generator, an induction motor requires an input of mechanical energy. That is, it will require mechanical *effort* to keep the rotor spinning faster than synchronous speed, since the motor naturally “wants” to spin at synchronous speed or slower. This means a generating motor acts as a brake, attempting to slow down whatever is keeping it spinning faster than synchronous speed. This braking effect is in direct proportion to how much the generated energy is used or dissipated by an electrical load. If we build a VFD to dissipate this energy in a controlled manner, the motor will have the ability to act as a *dynamic* brake.

In a VFD circuit, the “reverse” power flow received from the motor takes the form of currents traveling through the reverse-protection diodes placed in parallel with the output transistors. This in turn causes the DC bus filter capacitor to charge, resulting in a raised DC bus voltage:

*Generating currents through reverse-protection diodes*

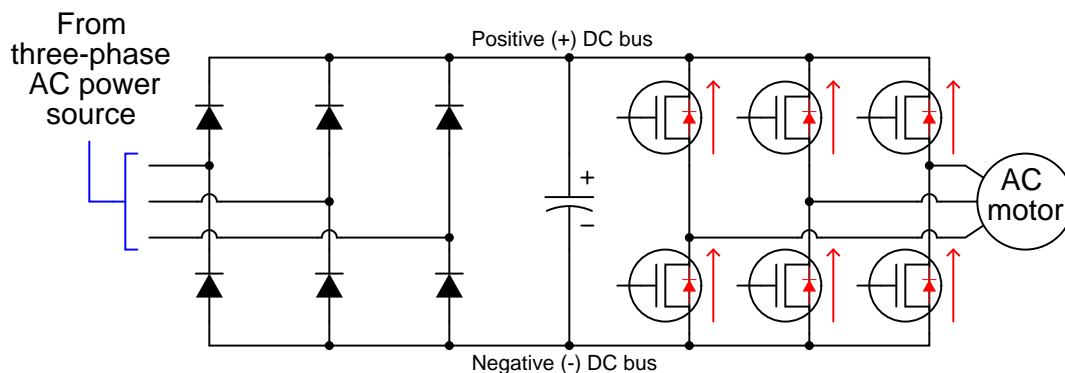

Without a place for this energy to dissipate, however, there will be little braking effort, and the capacitor will be quickly destroyed by the excessive DC bus voltage. Therefore, in order for dynamic braking to work, the VFD must be equipped with a *braking resistor* to dissipate the received energy. A special transistor rapidly switched on and off to regulate DC bus voltage ensures the capacitor will not be harmed, and that the braking is effective.

This next schematic diagram shows how a braking resistor and its accompanying transistor could be added to the simple VFD circuit. Once again, the switching circuitry used to turn the braking transistor rapidly on and off has been omitted for simplicity:

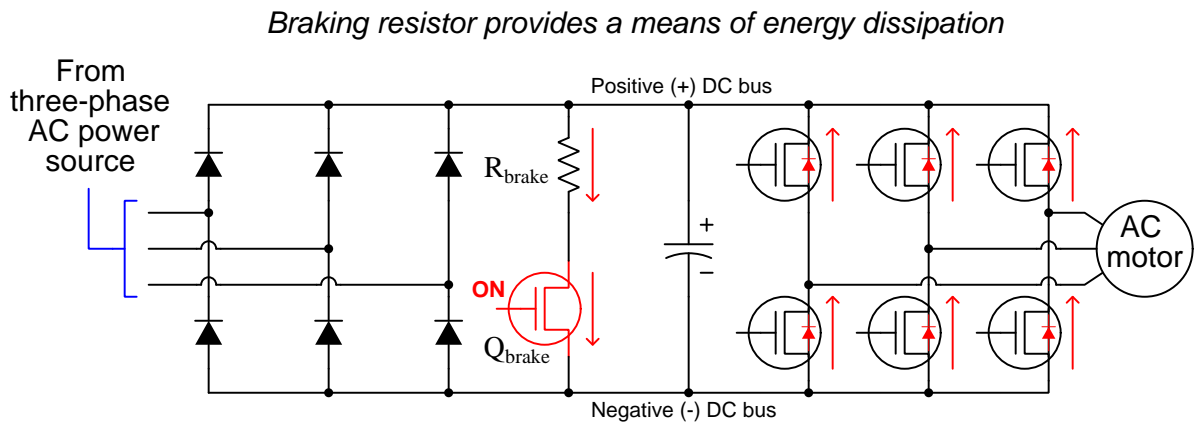

The braking transistor switches on in direct proportion to the DC bus voltage. The higher the DC bus voltage, the greater the duty cycle (on time versus total time) of the braking transistor. Thus, the transistor functions as a *shunt voltage regulator*, placing a controlled load on the DC bus in direct proportion to its degree of over-voltage. This transistor never turns on when the DC bus voltage is within normal (motoring) operating range. It only turns on to clamp DC bus voltage to reasonable levels when the motor spins faster than synchronous speed.

With this braking circuit in place, the only action a VFD must take to dynamically brake an AC induction motor is simply slow down the applied AC frequency to the motor until that frequency is less than the equivalent rotor speed (i.e. create a condition of negative slip speed).

As with DC injection braking, the braking torque created by dynamic braking is a function of magnetic field strength and rotor speed. More precisely, it is a function of the Volts/Hz ratio applied by the VFD to the motor, and the magnitude of the negative slip speed. Braking torque is primarily limited by the braking resistor's power rating and also the power rating of the VFD. Since the kinetic energy dissipation occurs outside the motor, there is little rotor heating as is the case with DC injection braking.

### 3.2.3 Regenerative braking

Regenerative braking takes the concept of dynamic braking one step further, in converting the DC bus over-voltage into usable AC power to be placed back on the AC line for other AC devices to use. Rather than regulate DC bus voltage via a shunt resistor switched on and off by a special transistor, a regenerative drive manages the same task by augmenting the bridge rectifier diode array with a set of six more power transistors, then switching those transistors on and off synchronously with the line voltage (the AC power source). This line-synchronized switching takes the DC bus voltage and “inverts” it to AC so that the drive may send real power back into the AC power system from whence it originated:

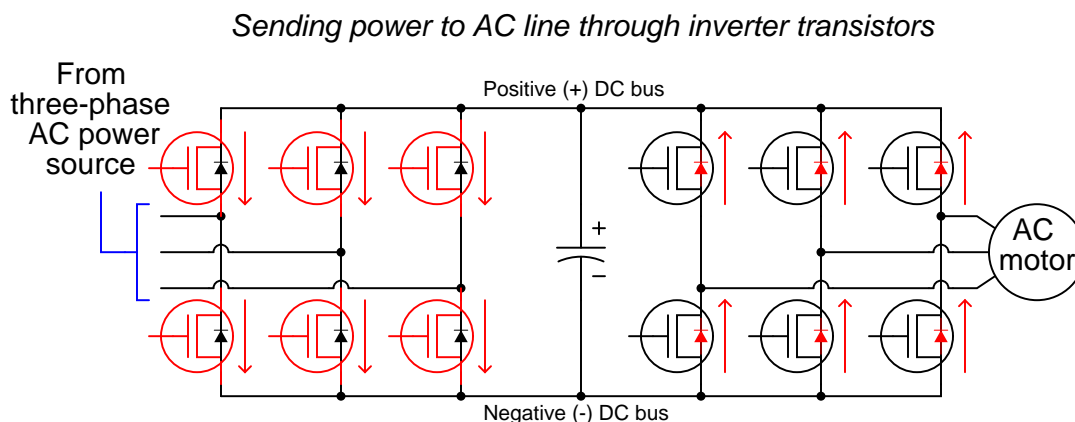

Rectifier circuits equipped with a set of line-synchronized power transistors are often referred to as an *active front end* to the motor drive. The term “active” refers to the transistors (diodes are “passive” devices), and the term “front end” simply refers to the bridge being at the incoming (front) side of the VFD power circuit. In such a drive, the front end’s transistors are sequenced as needed to clamp the DC bus voltage to reasonable maximum levels, just like the braking transistor is pulsed in a drive with dynamic braking to shunt-regulate DC bus voltage. If DC bus voltage in a regenerating drive rises too high, the active front end transistors will pulse for longer periods of time (i.e. with greater duty cycles) to apply more of that braking energy to the AC power grid.

Regenerative braking enjoys the unique advantage of putting the kinetic energy lost through braking back into productive use. No other method of motor braking does this. The cost of doing this, of course, is increased component count and complexity in the motor drive itself, leading to a more expensive and (potentially) fault-prone VFD. However, in applications where the recovered energy is significant, the cost savings of regenerative braking will rapidly offset the additional capital expense of the regenerative drive.

A simpler and cheaper way to enjoy the benefits of regenerative braking without adding a lot of complexity to the VFD circuitry is to take multiple VFDs and simply connect their DC bus circuits in parallel. If one of the drives slows down its motor, the raised DC bus voltage will be available at the other motor drives to help them drive their motors.

The following schematic diagram shows two interconnected VFD circuits, with the upper drive braking and the lower drive motoring (driving):

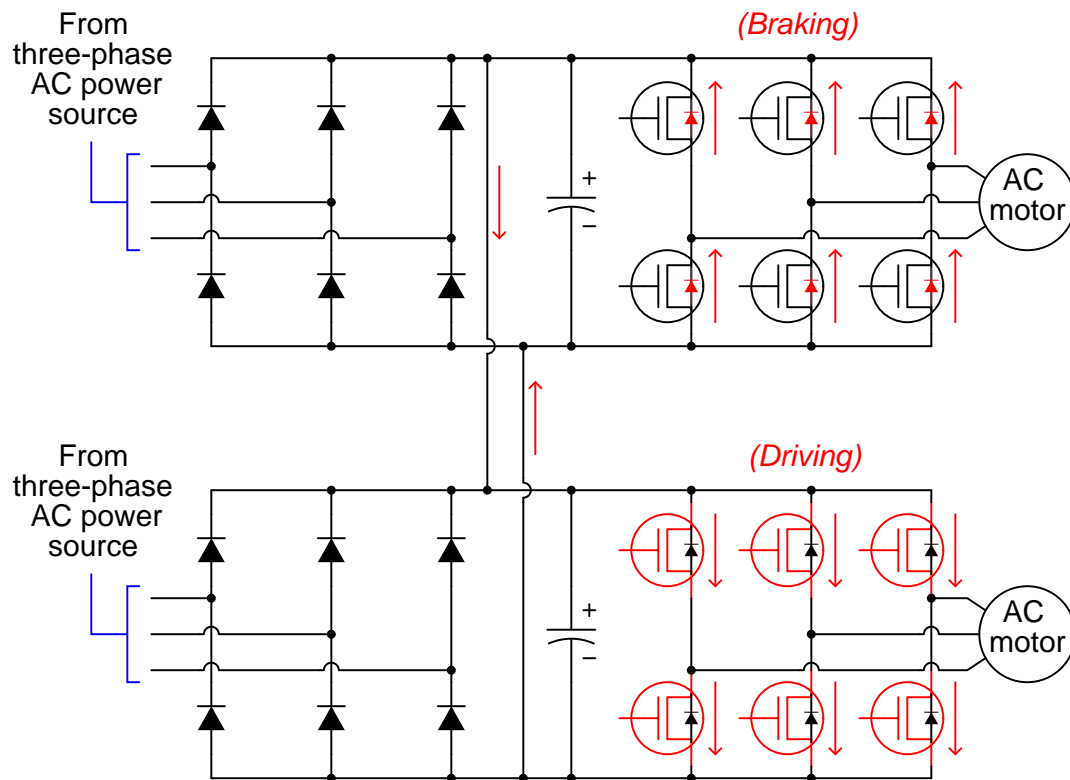

The major disadvantage to regeneratively braking in this fashion is that the braking energy is only recoverable by the other motor(s) with their DC busses paralleled, and only at the exact same time one or more of those motors are braking. This is not as convenient or practical as AC line regenerative braking, where a virtually unlimited number of loads exist on the grid to absorb the braking energy at any time. However, for certain applications<sup>6</sup> it may be practical, and in those applications the installed cost of the VFDs will be less than a comparable installation with AC line regeneration.

As with dynamic braking, motor heating is reduced (compared to DC injection braking) because the kinetic energy is dissipated elsewhere.

<sup>6</sup>One such application is machine motion control, where one part of the machine always needs to slow down while another part is accelerating. Another application is coupling the drive motors of two conveyor belts together, where one conveyor always lifts the load uphill and the other conveyor always lowers the load downhill.

### 3.2.4 Plugging

Plugging is the most powerful method of braking an electric motor, consisting of actively applying power to the motor in the opposite direction of its rotation. This is analogous to reversing the engine thrust of a power boat or an airplane in order to quickly bring it to a halt. For a VFD, this means a reversal of phase rotation while carefully applying power to the AC induction motor.

Like DC injection braking, plugging requires power be applied to the motor in order to make it stop, and it also results in all the kinetic energy being dissipated in the rotor. The advantage held by plugging over DC injection braking is that the braking torque may be maintained and precisely controlled all the way to zero speed.

### 3.3 Important VFD parameters

In order for a VFD to properly and safely control an electric motor, that drive must “know” certain things about that motor and its intended application. All AC motors have ratings for voltage, current, power, etc. and these ratings are typically found written on a metal *nameplate* affixed to the frame where they may be easily read. These “nameplate” ratings must be programmed into the VFD so that the drive is aware of the motor’s limitations. Failure to properly configure an electronic motor drive with these “base” parameters may result in damage to the motor, for example if the drive is configured to output more current than the motor is rated for! As such, it is recommended that you *first* program these parameters into a motor drive before setting any other drive parameters.

The following photograph shows the nameplate on a 300 Horsepower three-phase electric motor:

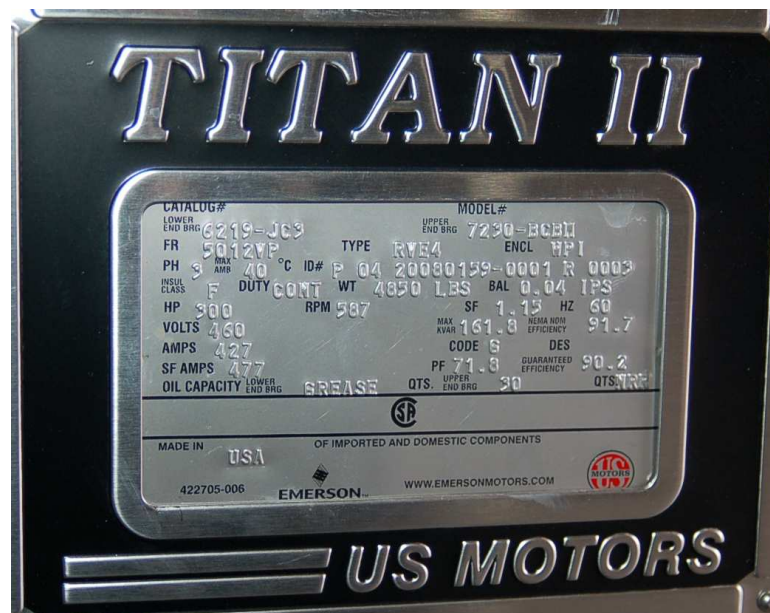

Critically important “base” parameters for any VFD tasked with safely controlling this motor include the **rated voltage** (460 Volts), **full-load current** (427 Amperes), **base frequency** (60 Hz), and **shaft speed**<sup>7</sup> (587 RPM) at that base frequency of 60 Hz. If the VFD’s output voltage is too low for any given frequency, the motor will develop insufficient torque. If the VFD’s output voltage is too high, there will a danger of magnetically saturating the motor’s stator or rotor iron. If the VFD’s output current is set too low, it may limit itself to some speed less than desired when that current limit is reached. If the VFD’s output current is set too high, there will be a danger of damaging the motor, as the VFD will not “know” when the motor becomes overloaded.

In case you’re wondering, the “SF” and “SF Amps” nameplate ratings refer to the motor’s *service factor*, representing the amount of overload it can safely withstand for short durations of

<sup>7</sup>It is worth noting that some VFDs do not have a shaft speed parameter, but are “aware” only of frequency values. Any VFD designed to control an AC motor to some target shaft speed, however, *must* know the equivalence between base frequency and base shaft speed.



time. These should never be used as “base” parameters because they do not reflect what the motor is *continuously* capable of.

Beyond “base” motor nameplate parameters, other VFD parameters are necessary in order to ensure safe and efficient motor operation. Some of these are listed in the following subsections. Please note that VFD features and details vary widely with the model, and that the following descriptions of features are quite generic. Your best source of detailed information about any specific VFD model is the user’s manual for that particular VFD.

### 3.3.1 Maximum and minimum speed (frequency)

Since VFDs synthesize their own sinusoidal voltages and currents and are not bound to the line frequency, it is possible to configure a VFD to output frequencies greater than that of the line, allowing the motor to exceed its base (nameplate) shaft speed. Some VFDs express this maximum as a frequency value, while others specify it as a shaft speed value.

If an AC motor has a maximum speed printed on its nameplate, the VFD’s maximum speed (or equivalent frequency) should obviously never exceed this value. However, not all applications require the motor to achieve its maximum safe speed, and so this VFD setting will be application-specific.

Conversely, in some applications where speed control all the way down to standstill is either unnecessary or undesired, the VFD may be configured for a *minimum* speed or equivalent frequency. The motor speed will, of course, always go to zero when the VFD is commanded to stop the motor, but while running the VFD will never output a frequency below this minimum pre-set value.

### 3.3.2 Acceleration and Deceleration time

VFDs limit the rate at which they increase and decrease output frequency, thereby limiting the rate at which the motor’s shaft speed increases or decreases (i.e. angular acceleration/deceleration). The concerns of acceleration and deceleration rates are both mechanical and electrical. Rapid acceleration or deceleration places stress (torque) on rotating machine components, as greater torque is necessary for greater acceleration<sup>8</sup>. Rapid acceleration results in high inrush current as the motor’s speed increases. Rapid deceleration results in high braking current and elevated DC bus voltage within the VFD, placing extra stress on VFD power components. The acceptable acceleration or deceleration rate for any VFD-controlled motor is therefore largely application-specific, as it is a function of the total mechanical inertia of the motor *and* the machine it drives.

### 3.3.3 Stopping method

When a VFD is commanded to stop a motor, it may do so in two very different ways: (1) cutting off all power to the motor and letting it coast to a stop, or (2) gradually ramping the target speed of the motor to zero. The second option may require the VFD to actively *brake* the load if it has a large amount of inertia (i.e. if its natural tendency to coast would take longer than the ramp-to-stop profile).

---

<sup>8</sup>This is a basic principle of physics. Newton’s Second Law of Motion describes how the acceleration (or deceleration) of any mass is proportional to the force acting upon that mass ( $F = ma$ ). The rotational (angular) version of this formula is  $\tau = I\alpha$ , where  $\tau$  is torque in units of Newton-meters,  $I$  is the *moment of inertia* of the rotating mass in kilogram-meters squared, and  $\alpha$  is the angular acceleration in units of radians per second squared.

### 3.3.4 Volts per Hertz profile

A VFD must reduce its output voltage to the AC motor as it reduces frequency, in order to limit line current and avoid magnetically saturating the motor's iron<sup>9</sup>. The most rudimentary way to do this is to set output voltage as a direct proportion of output frequency (e.g. 100% voltage at base frequency, 50% voltage at half-speed, etc.). However, a constant proportion of Volts to Hertz (i.e. a fixed V/F or V/Hz ratio) across the VFD's speed range is not always the best for any given application.

When powering variable-torque mechanical loads such as fans and centrifugal pumps, a VFD can output less than 50% voltage at half-speed because not as much torque (current, magnetic flux) is necessary to maintain the slower shaft speed. This reduced motor heating (i.e. improves energy conversion efficiency) and reduced line current, both of which are universally desirable.

When powering constant-torque mechanical loads such as conveyors, elevators, and positive-displacement compressors, it is advantageous to *boost* the motor's terminal voltage at low speeds in order to generate more torque at its shaft than would otherwise occur with a constant V/F ratio. This helps the motor start up from a standstill, and allows it to bear heavy mechanical loads at low speeds. However, this feature comes at a price: the motor will draw more current and dissipate more heat than it would otherwise, and so additional cooling<sup>10</sup> may be necessary for reliable operation.

---

<sup>9</sup>The amount of magnetic flux inside of an electromagnet is directly proportional to the amount of current passing through the wire winding, and also proportional to the *Volt-second* product of applied voltage and time. If too much voltage is applied across the coil for too long a time, the magnetic flux intensity will build up to values capable of saturating the iron, at which point and additional applied voltage simply results in relatively large amounts of current (i.e. the incremental inductance of that electromagnet dramatically decreases). Not only does magnetic saturation result in excess heat dissipated in the iron, but the excess coil current also dissipates unwanted heat, both effects resulting in undue thermal stress to the machine. Reducing output voltage from a VFD as a function of reduced frequency helps maintain a more constant Volt-second product, and thereby avoids magnetically saturating the iron.

<sup>10</sup>One practical option is to equip the motor with its own electric cooling fan rather than rely on the standard shaft-driven fan sported by most AC induction motors. This will provide a full blast of cooling air to the motor even when the motor's shaft may be turning very slowly.

For some VFDs, the V/F profile incorporates boost for constant-torque applications, while in other VFDs *any* available V/F profile may be augmented with a “DC boost” option. As usual, the user’s manual for your specific VFD will be your best guide. Some V/F profiles commonly offered by VFDs include the following:

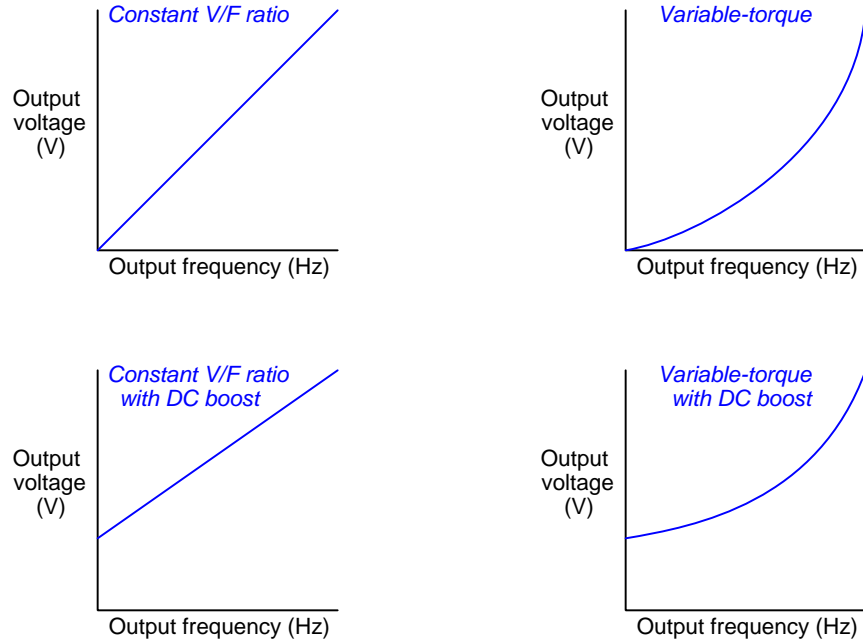

### 3.3.5 PWM frequency

The frequency at which the VFD’s output transistors pulse on and off is also configurable in many VFDs. Note that this is entirely unrelated to the frequency of the synthesized sine-wave voltage/current determining motor shaft speed, as PWM frequency<sup>11</sup> refers to the pulses *within* each cycle of the synthesized sine wave. As PWM frequency increases, audible noise from the motor generally decreases in volume while electromagnetic interference emitted by the motor increases, as does eddy-current losses in the iron laminations of the motor’s stator and rotor. Optimal PWM frequency is usually determined experimentally.

When operating a VFD at high PWM frequencies, *de-rating* of motor horsepower may be necessary as a result of the increased heating that eddy currents in the motor’s iron core produces.

---

<sup>11</sup>Sometimes referred to as *carrier frequency*, because the use of a high-frequency signal to synthesize a lower-frequency signal is similar to *amplitude modulation* (AM) technology where a constant-frequency “carrier” wave is modulated in amplitude over a slower period to convey audio-frequency information over a radio-frequency channel.

### 3.3.6 Current limiting

A basic feature of any VFD is automatic shut-down in the event of motor overcurrent, usually based on the nameplate (base) motor line current parameter. If the VFD senses motor current exceeding this pre-set value for some short length of time, it will automatically shut off and output a fault message indicating the nature of the shutdown. The VFD will have to be re-started in order to resume control of the motor.

Some VFDs go one step further and actively limit motor current if it exceeds a certain value. This *current limiting* feature causes the VFD to reduce its target speed (i.e. output frequency, and along with that its output voltage) in order to not exceed the pre-set motor current limit. Thus a VFD equipped with current limiting will respond to a high motor current by reducing motor speed rather than simply shutting down completely.

### 3.3.7 Start/stop source

VFDs typically come equipped with pushbutton controls on their faceplates allowing manual starting, stopping, and reversing of the motor. However, this is not the only way to command a VFD to start, stop, or reverse. Alternative methods for triggering a VFD to start, stop, or reverse a motor include external switch contacts and digital network messages.

External switch contacts wired to terminals on the VFD will not be heeded unless and until certain parameters within the VFD are properly set. It is common for VFDs to provide user-selectable options such as faceplate control only (default), external switches (usually in multiple configurations) only, or both.

Digital network control is a very popular method for commanding VFDs to start, stop, and reverse motor direction. Broadcast-style networks allow multiple VFDs to communicate over single lengths of communications cable by assigning a network *address* to each VFD. The controlling computer calls out each VFD by its address while transmitting the start/stop/reverse commands, so that only the intended VFD on that network responds.

### 3.3.8 Speed reference source

VFDs typically come equipped with pushbutton controls or rotary knob controls on their faceplates allowing manual speed control of the motor. However, as with starting, stopping, and reversal, this is not the only way to command a VFD to set motor speed. Alternative methods for setting motor speed include external potentiometers (powered by the VFD), external analog current signals (e.g. 0-20 mA, 4-20 mA), external analog voltage signals (e.g. 0-10 V, 1-5 V), and digital network messages.

The same digital networks capable of commanding a VFD to start, stop, and reverse a motor may be used to convey speed command messages, with all the same advantages.

### 3.3.9 Skip frequency

The output of a VFD is obviously *variable*, since that is what the letter “V” stands for in VFD, but sometimes a particular output frequency can be problematic for the machine or for the electrical system the VFD is connected to. If a machine has a certain *critical speed* at which it tends to vibrate, the VFD needs to be programmed to avoid operating at that speed (equivalent frequency). Likewise, if the electrical network powering the VFD contains harmonic filter circuits that could dangerously resonate at certain drive frequencies (or at harmonics of certain drive frequencies), those frequencies should be avoided.

For these purposes, some VFDs offer *skip frequency* settings which forbid the VFD to output power at the specified frequency(ies). If the VFD’s output frequency must increase or decrease past a “skip” frequency value, it will do so by “jumping” past that value.

### 3.3.10 Fault recovery

Some faults flagged by a VFD are more important than others. For severe faults (e.g. electrical ground fault detected), the VFD will refuse to re-start the motor unless and until the fault has been manually cleared by a human technician. For other faults, automatic-restarting is an option. Note that a parameter within the VFD may need to be properly set in order to activate this feature!

### 3.4 Line reactors

Regulating the electric power sent to an electric motor is a task performed by high-speed switching transistors inside a motor drive, modulating the pulse-width of a high-frequency square wave to the motor. The high-speed switching happening inside of a motor “drive” circuit results in the drive drawing current from the AC power source as high-frequency pulses rather than as sinusoidal waves. These current pulses tend to distort the voltage of the AC power source so that other devices powered by the same AC source will “see” high-frequency noise on the power lines. This is true for DC and AC motor drives alike:

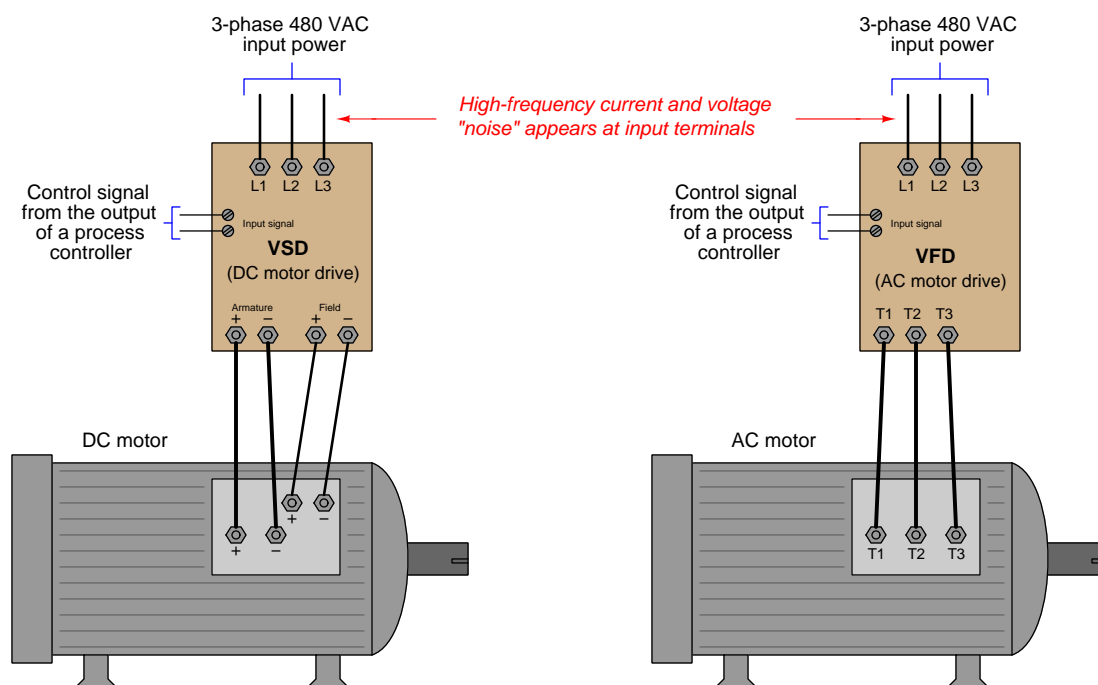

As French mathematician and physicist Jean Baptiste Joseph Fourier (1768-1830) mathematically proved centuries ago, any repeating waveform – no matter how strange the shape may be – is equivalent to a series of sine and cosine waves at integer multiples (“harmonics”) of some fundamental frequency. Thus, the normal sine-wave AC power supplied to an operating motor drive unit will be tainted by harmonic frequencies in addition to the fundamental frequency of 60 Hz<sup>12</sup>.

Such high-frequency noise may be very troublesome to nearby electronic devices and to other electrical components connected to the same AC power system. Power transformers will suffer increased core heating from harmonic currents. System capacitances and inductances may *resonate*

<sup>12</sup>In Europe, the fundamental power line frequency is 50 Hz rather than 60 Hz. Also noteworthy is the fact that since the distortion caused by motor drives is typically symmetrical above and below the center-line of the AC waveform, the only significant harmonics will be odd and not even. In a 60 Hz system, the odd harmonics will include 180 Hz (3rd), 300 Hz (5th), 420 Hz (7th), and higher. For a 50 Hz system, the corresponding harmonic frequencies are 150 Hz, 250 Hz, 350 Hz, etc.

at these harmonic frequencies causing high currents and voltages to form. So-called *triplen harmonics*<sup>13</sup> are especially troublesome in three-phase power circuits, where they tend to add in the neutral conductors of Wye-connected system components and circulate through the phase elements in Delta-connected system components. In some industrial installations, the magnitude of triplen harmonic currents in a 4-wire Wye system have been so great that the neutral conductor actually overheated from excessive current, even though the three line conductors were well within their rated load current capacities!

One method useful to combat these effects is to *filter* harmonic frequencies from the rest of the AC power system, preventing the subsequent “corruption” of the AC power source by the motor drive’s pulsing currents. The most direct way to filter harmonic frequencies is to use an electrical component acting as a low-pass filter – a simple *inductor* connected in series with the motor drive. For three-phase-powered motor drives, this takes the form of three inductor elements, commonly referred to in industry as *reactors* because they add (inductive) reactance to the circuit:

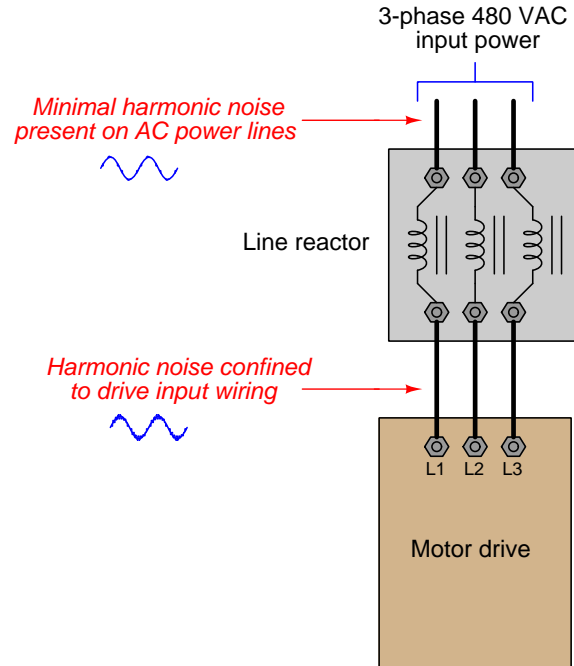

Line reactors work by presenting a greater series impedance to high-frequency harmonic currents than to low-frequency fundamental currents, following the inductive reactance formula  $X_L = 2\pi fL$ . The greater the frequency ( $f$ ) of current, the greater the inductive reactance ( $X_L$ ) and therefore the greater the attenuation of that current through that conductor. This effect is particularly strong for

<sup>13</sup>Harmonic voltages and currents whose frequencies are multiples of three of the fundamental (e.g. 3rd, 6th, 9th, 12th, 15th harmonics). The reason these particular harmonics are noteworthy in three-phase systems is due to their relative phase shifts. Whereas the fundamental phase shift angle between different phase elements of a three-phase electrical system is  $120^\circ$ , the phase shift between triplen harmonics is zero because  $3 \times 120^\circ = 360^\circ = 0^\circ$ . Thus, triplen harmonics are *directly additive* in three-phase systems.

triplen harmonic currents, as these always flow in the same direction through the power conductors at any given time, having zero phase shift between them unlike the fundamental currents which are phase-shifted by 120 degrees. Whereas the magnetic fields created by the three coupled inductors in each line reactor will cancel for out-of-phase currents, magnetic fields created by in-phase currents such as triplen harmonics will mutually reinforce each other for maximum inductive reactance. As one might expect, line reactors cannot *prevent* harmonic distortion in the AC power system, but they do a great deal to mitigate the ill effects of harmonics produced by a motor drive.

Line reactors may also be used on the *output* of an AC motor drive to filter harmonics from the motor itself. Like transformers, AC induction motors suffer greater core losses when exposed to harmonic currents, causing the motor to heat up more than it would if powered by AC power of one pure frequency:

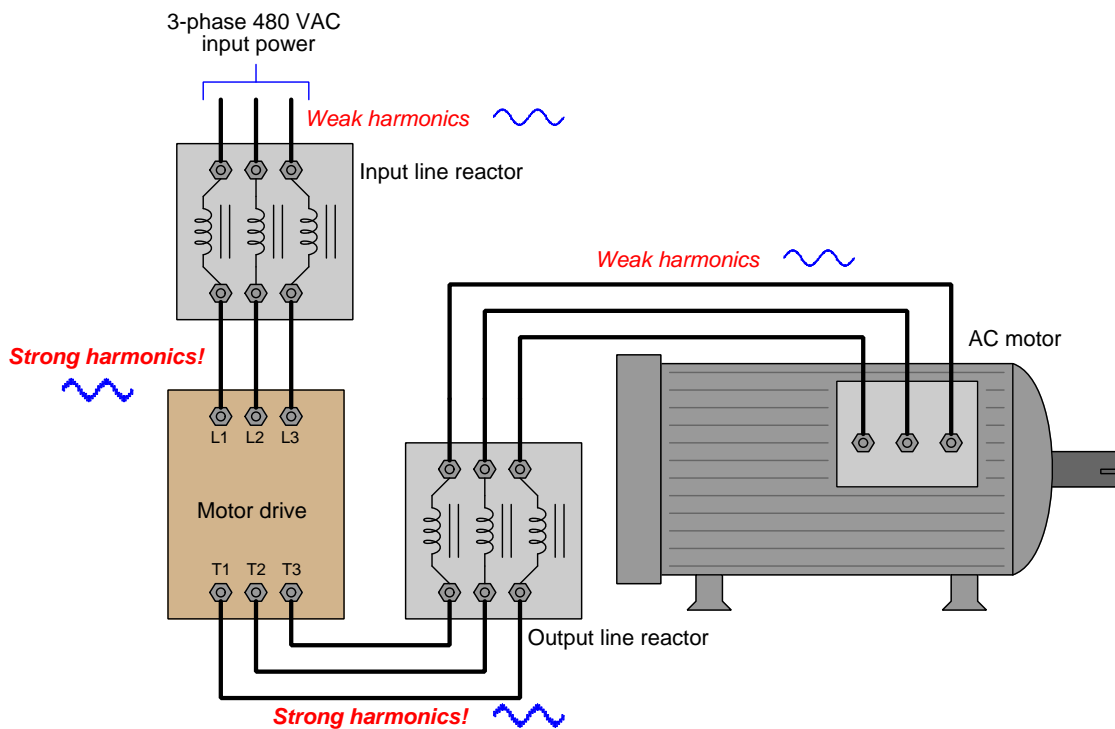

The presence of strong harmonic distortion on the motor drive's input wiring means those conductors should be kept short as possible to minimize electromagnetic interference with nearby electrical and electronic components.

Not only do output line reactors help reduce heating effects in the AC motors powered by variable-frequency drives, the reactors also reduce the severity of fault currents resulting from short-circuit transistor failures in the motor drive, as well as minimize the ill effects of reflected signals in the conductors stretching between the output line reactor and the motor itself<sup>14</sup>. With such benefits

<sup>14</sup>As you may recall, any sufficiently long set of conductors will act as a *transmission line* for high-frequency pulse



arguing for the installation of line reactors in variable-speed motor control circuits, the only reason for their non-installation is added expense, and/or insufficient space inside the enclosure with the motor drive.

A photograph of a three-phase line reactor is shown below, conditioning power for multiple VFDs. The large conductors on top connect to the incoming power feed, while multiple white, blue, and red wires of smaller gauge route power to multiple VFD units:



In addition to line reactors, another method of reducing the amount of electrical noise coupled from a VFD and its motor to surrounding electronic circuits is to use *shielded cable* for all<sup>15</sup> power conductors. A shielded cable contains a layer of either metal foil or metal wire braid wrapped over the individually insulated internal conductors, and in the case of foil shielding a bare “drain” conductor to attach the cable shield to Earth ground at one end of the cable.

---

signals. An unterminated (or poorly-terminated) transmission line will *reflect* pulse signals reaching its ends. In the case of a motor drive circuit, these reflected pulses may constructively interfere to produce nodes of high voltage or high current, causing premature wiring failure. Output line reactors help minimize these effects by filtering out high-frequency pulse signals from reaching the long motor power conductors.

<sup>15</sup>Shielded cable for input power wiring to the VFD is less important than shielded cable for the VFD output power wiring to the motor, because it is the VFD’s output that is richest in harmonic content.

## Chapter 4

# Derivations and Technical References

This chapter is where you will find mathematical derivations too detailed to include in the tutorial, and/or tables and other technical reference material.

## 4.1 Electrical safety

A subject of extreme importance to all electrical practitioners is electrical *safety*, with Ohm's and Joule's Laws being excellent starting points for a discussion on that topic. Here we examine the human body as an electrical *load*: electrical charge carriers passing through the resistance of the body from an external source relinquish some of their energy in the same way charge carriers lose energy passing through any other resistance. The rate of energy dissipation (i.e. *power*) through the body's resistance is predicted by Joule's Law,  $P = I^2R$ . The total amount of energy delivered to a body by an electric current is a function of that power dissipation rate multiplied by the amount of time current flowed<sup>1</sup>.

Electrical energy poses two distinctly different threats to any living body: the first threat is forced activation of the body's nervous system by electric current passing through nerve cells, and the second threat is burning from the thermal power dissipated in flesh and bone. Both threats are direct functions of the amount of energy delivered to the body, with the first effect (called *electric shock*) beginning at lower levels of current than the second effect.

Electric shock – not to be confused with the general condition of *circulatory shock* characterized by reduced blood circulation in the body – first manifests as a tingling sensation, then as pain with greater electric current intensity. At a certain threshold value, the current will be sufficient to override voluntary muscle control. At higher levels of current, breathing will become difficult or may cease due to paralysis of the diaphragm muscles within the chest. At even higher levels of current, the heart (itself a muscle of the body) will either fall into an arrhythmic beat pattern or cease beating altogether. *All of these effects will occur at current levels significantly less than one Ampere.*

Some of the most detailed data we possess on the effects of electric shock come from the research of University of California Berkeley Professor Charles Dalziel, who in the year 1961 published a report entitled “Deleterious Effects of Electric Shock”. Dalziel performed electric shock experiments on human volunteers, subjecting both males and females to varying degrees of electric current, both direct (DC) and alternating (AC), for the purpose of determining thresholds of sensation, pain, and loss of muscular control.

Table II of Dalziel's' report (shown on page 24) is partially<sup>2</sup> reproduced in the following table. The headings “M” and “F” refer to male and female subjects, respectively. Tests conducted using direct current<sup>3</sup> are labeled “DC” while tests conducted using alternating current<sup>4</sup> are labeled with

---

<sup>1</sup>Putting units of measurement to this concept, the amount of energy in *Joules* is equal to average power in *Joules per second* multiplied by time in *seconds*, with the unit of “seconds” canceling out. For brief exposures to electricity, such as lightning strikes, the most important measurement with regard to safety is the total energy delivered to the body. The same is true for deliberate applications of electricity to the body, for example cardiac defibrillators, where the machine's setting is calibrated in Joules of energy delivered per impulse.

<sup>2</sup>The original Table II contained a column of data representing thresholds for women at 10 kHz alternating current, but these were estimations and not actual data. Extrapolating from the other data points where women tended to exhibit the same effects as men at approximately  $\frac{2}{3}$  the current, Dalziel writes, “*Tests on women were not made on frequencies other than 60 cycles, but if it is assumed that the response for women would be similar, values for women can be estimated at two-thirds of the corresponding value for men.*” Readers should note that I have taken editorial liberties with the description of bodily effects, for no reason other than formatting.

<sup>3</sup>Direct current, or DC, refers to a continuous flow of electric charge carriers in one direction only.

<sup>4</sup>Alternating current, or AC, refers to an electric current that periodically switches direction, the period of that

*frequency* values expressed in the unit of Hertz (Hz) or cycles per second. All data points are expressed in *milliAmperes* (mA), one milliAmpere being  $\frac{1}{1000}$  of an Ampere:

<b>Bodily effect</b>	<b>DC, M</b>	<b>DC, F</b>	<b>60 Hz, M</b>	<b>60 Hz, F</b>	<b>10 kHz, M</b>
Slight sensation felt on hand	1 mA	0.6 mA	0.4 mA	0.3 mA	7 mA
Median perception threshold	5.2 mA	3.5 mA	1.1 mA	0.7 mA	12 mA
Shock, with no loss of muscular control	9 mA	6 mA	1.8 mA	1.2 mA	17 mA
Pain, with 50% of subjects losing muscular control	62 mA	41 mA	9 mA	6 mA	55 mA
Pain, labored breathing, 99.5% of subjects losing muscular control	90 mA	60 mA	23 mA	15 mA	94 mA

For rather obvious reasons no human tests were conducted to the point of cardiac fibrillation. Dalziel's report does, however, provide data collected on a variety of animals (pigs, sheep, calves, dogs, cats, guinea pigs, rabbits) which were anesthetized and then administered large amounts of electric current until their hearts malfunctioned. From this admittedly limited data, Dalziel extrapolated the values to obtain 500 mA ( $\frac{1}{2}$  Ampere) of direct current and 100 mA ( $\frac{1}{10}$  Ampere) of alternating current as thresholds for "possible" human heart fibrillation following a three-second electric shock.

All gruesome details aside, the lesson to be learned here is very plain: *very little electric current is necessary to induce painful and even life-threatening effects on the human body!* These danger thresholds are all substantially less than the amount of current most power conductors are rated to handle, and less than the ratings of fuses and circuit breakers designed to protect conductors from overheating.

---

switching measured in cycles per second or Hertz. In North America, the standard AC grid power frequency is 60 cycles per second, or 60 Hz. The second AC frequency used in Dalziel's experiments is 10 kHz, which is 10 *kilo*-Hertz, or 10000 cycles per second.

The first line of defense against electrical shock is to place as much electrical resistance between your body and the circuit's conductors as is practical, as a means of impeding the flow of electric current to and through your body. Turning "off" any disconnecting switches between the circuit and its energy source is a simple means to do this, essentially inserting an air gap between the circuit and its normal source of power. This allows all points within the circuit to achieve an equipotential state, which may then be made equipotential to your body by connection to Earth ground (where you are standing). If there is no voltage present (i.e. no difference in the potential energy levels of electric charge carriers at different points), then there should be no possibility of dissipating electrical energy into your body.

Once all electrical energy sources have been disconnected from the circuit you intend to work on, an additional safety measure is to *bond* that circuit's power conductors to Earth ground. This step forces the power conductors to be *electrically common* with Earth, and therefore guarantees a condition of equipotentiality with the Earth. Line workers who install and maintain electric power line conductors do this as a standard part of their operating procedure: attaching temporary grounding cables between the power conductors and Earth after opening all disconnect switches normally connecting those lines to electrical sources. This extra step of bonding the power conductors ensures no stray sources<sup>5</sup> of electrical energy may pose a threat.

The following photograph shows a work site at a 230 kV (230,000 Volt!) electrical substation, where electricians are busy performing maintenance work on a high-voltage component. In addition to opening large switches (called *disconnects*) to isolate this new component from any source of voltage, they have taken the additional step of *bonding* the high-voltage conductors to each other and to Earth ground by means of temporary wire cables. The cables on this work site happen to be yellow in color, and may be seen hanging down from C-shaped clamps attached to three horizontal metal tubes called *busbars* which serve as conductors for electricity in this substation:

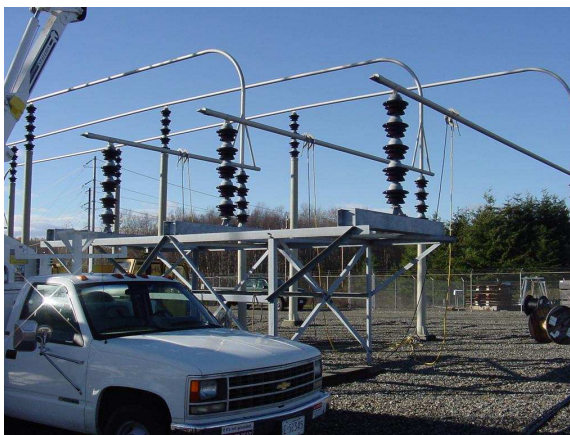

---

<sup>5</sup>Examples include electrostatic or magnetic "coupling" with adjacent energized power lines, nearby lightning strikes, etc.

Obviously, such measures are quite necessary on high-voltage systems such as substation busbars – there simply is no safe way to work on energized conductors at this voltage level. However, in lower-voltage circuits it is often necessary to take electrical measurements and make certain adjustments while the circuit is in an energized state. If the circuit in question cannot be “killed” by disconnection of its power source and therefore must be worked on “live”, the next best protective measure is to layer insulating material on your body where contact might otherwise be made to permit an electric current through it. This means wearing insulating gloves and shoes, at minimum. The principle behind this technique is Ohm’s Law: for any given amount of voltage ( $V$ ), current ( $I$ ) will be inversely proportional to the total resistance ( $R$ ) of the circuit pathway. Layering electrically insulating material over your body’s possible points of contact (e.g. hands, feet) increases the total resistance of the circuit pathway, and therefore minimizes the amount of current that may flow in the event of physical contact between two points where a substantial voltage exists.

Lastly, in order to minimize the risk of electric current passing through one’s chest (where the heart and diaphragm muscles are located), a wise habit when working on energized circuits is to place one hand in a pocket so that only one hand is in use. This will not only prevent arm-to-arm passage of electric current, but it also minimizes the number of potential points of contact with bare skin. Electrical practitioners commonly refer to this as the *One-Hand Rule*. Ideally, the best hand to place in a pocket is the left hand, because this is the side of the body where the heart is most vulnerable.

It is worth noting that the danger from electric shock is best quantified in terms of current, not voltage, since it is electric current that activates nerve cells. The amount of current passing through a victim’s body from an applied voltage is a function of Ohm’s Law ( $I = \frac{V}{R}$ ), and since resistance ( $R$ ) varies greatly with skin dryness and layering provided by shoes and clothing, it is difficult to predict how much voltage poses a shock hazard. A generally accepted threshold of danger is 30 Volts, but this assumes direct contact with dry skin. Moist skin, perspiration, cuts or punctures, and other factors reducing body resistance may greatly reduce the voltage threshold for shock hazard! Another factor is the general health of the victim prior to receiving the electric shock. A preexisting cardiac condition will likely predispose that individual to harm resulting from an electric shock.

Burns produced by electricity passing through the body may manifest on the skin, at the point of contact with an electrical conductor (such as a wire), or in severe cases may extend to internal organs. Comparing internal flesh with skin, dry human skin tends to exhibit much greater levels of electrical resistance than the internal organs which are wet. This is why electricity causes skin-surface burns before causing internal organ burns: for any given amount of electric current passing through different resistances, power dissipated by that current will be greatest at the area greatest resistance. Mathematically stated,  $P$  is maximized where  $R$  is greatest, given any value of ( $I$ ), in accordance with Joule’s Law ( $I^2R$ ).

Another mechanism of electrically-caused burns is *arc flash*: the heating of air by the passage of electric current through it (rather than through the body). Under normal conditions air is an extremely good insulator of electricity, with no free charge carriers available to sustain an electric current. However, when sufficient voltage causes the electrons in air molecules to separate from their respective atoms, the negatively-charged electrons and positively-charged ions constitute charge carriers, and will form an electric current called either a *spark* or an *arc*. This current heats the air molecules by dissipating power as described by Joule’s Law ( $P = I^2R$ ), with  $I$  being the magnitude of current traveling through the ionized air and  $R$  being the resistance of the arc path.

The amount of resistance exhibited by a high-temperature arc is surprisingly low, typically less than one Ohm across the entire length of the arc. With such low resistance, Ohm's Law predicts relatively high current values for even modest voltages ( $I = \frac{V}{R}$ ), resulting in high power levels. Even if the amount of energy released by each charge carrier moving through the arc is small, the fact that a great many charge carriers are moving through the arc each second means that the total amount of energy dissipated may be phenomenally large. This is why arcs forming in high-voltage electric power systems may reach temperatures of tens of thousands of degrees<sup>6</sup>!

In the United States of America, a widely respected standard document for electrical hazards and protection is the National Fire Protection Association (NFPA) standard 70E. This document rates both electric shock and arc flash hazards for electric power circuits based on voltage and current capabilities, as well as specifies best practices for protection against those hazards.

An example of NFPA 70E standards applied to an industrial installation is the following pair of photographs showing warning labels affixed to metal-clad electrical switchgear (i.e. metal cabinets housing large circuit breakers). Each label cites both arc flash and electric shock hazards, including *boundary* distances within which greater hazards exist:

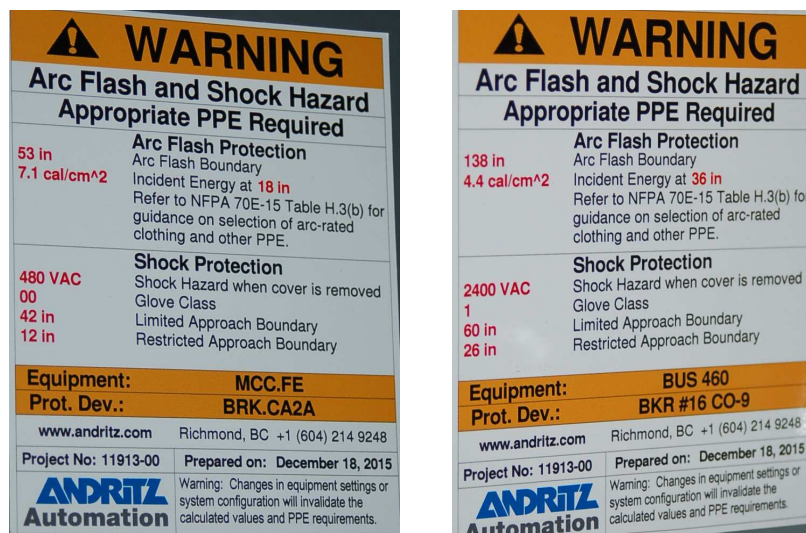

The first line of defense against arc flash is the same as for electric shock: *de-energize the circuit* so there will be no electrical energy present to harm you. The procedure for de-energizing includes placing a warning *tag* as well as a secure *lock* on any main disconnecting switches or circuit breakers to ensure power does not get accidentally applied to the circuit while people are in harm's way. This is referred to in industry as *lock-out, tag-out, or LOTO*.

<sup>6</sup>The NFPA 70E electrical safety standard (Informative Annex K) cites temperatures as high as 35,000 degrees Fahrenheit in arc flash events, and states that such events are lethal at distances up to 10 feet (3.05 meters). It is worth noting that electric arc temperatures are limited only by the rate of power dissipated in the arc. Unlike chemically-driven combustion events, where temperature is limited by the rate at which the various chemical reactants are able to combine, no such limiting factor exists with electric arcs: the more power dissipated in the arc, the hotter it will become. These temperatures involved with electric power faults can be so high that they *vaporize* the metal wires!

Generally accepted lock-out, tag-out procedures for electrical equipment include (but are not limited to) the following steps:

1. Turn equipment off using regular on/off switch to interrupt load current
2. Open all disconnect switches and/or circuit breakers feeding electrical power to the equipment
3. Visually confirm (if possible) that *all* poles of the disconnecting switch(es) are open
4. Attempt to re-start equipment as your first confirmation that power is indeed shut off
5. Attach locks and tags to prevent disconnecting switches from being re-closed; if no lockable disconnect means exists, you must open and tag *two* or more redundant disconnects!
6. Confirm proper operation of voltage meter against a known source
7. Test for dangerous voltage between all relevant conductors, especially those you could bodily contact, including between pairs of phase conductors in a polyphase system as well as between each phase conductor and earth ground
8. Confirm (again) proper operation of voltage meter against a known source

Such a lengthy procedure may seem paranoid, but there is good reason for all these steps. Remember that *all safety standards and procedures are written in blood*: in other words, every one of them exists because either someone got hurt or came close to getting hurt by not taking appropriate precautions. One example of the latter is the following photograph generously shared by Jim Lyon<sup>7</sup> who discovered a failed three-phase disconnect switch during a routine LOTO procedure:



As you can see in this photograph, one of the linkages between the disconnecting switch pole and the actuating lever has broken, allowing one phase to remain closed while the other two opened as they should. Such a failure would neither be apparent to the operator of that switch nor by anyone's external inspection of it, but would be revealed by proper voltage testing (phase-to-ground) on that faulted phase conductor. Had Mr. Lyon simply trusted the switch handle's "off" position as proof of a zero-energy state, he could have been electrocuted touching the un-opened conductor "downstream" of the switch.

---

<sup>7</sup>Mr. Lyon granted me permission to include his safety-related photographs in my open-source writings during an exchange on the professional social-media website [LinkedIn](#).



Another important note with regard to electrical safety and LOTO is the proper function of your test equipment. Multimeters and test leads are not just tools for precision measurement, but are life-saving indicators of dangerous voltage. I have personally witnessed multiple instances of failed multimeter test leads, where one or more leads failed open such that the meter could not reliably register the presence of voltage. This is why good LOTO procedure always includes verification of the meter both *before and after* checking for dangerous voltages at the system conductors.

In cases where de-energization is not possible or not practical, special “arc-flash rated” clothing may be worn to protect your skin against the high temperatures of arc flash should an arc flash occur. Arc flash suits cover all skin surfaces, and are rated according to the number of calories<sup>8</sup> of heat the fabric may sustain without disintegrating. The following photograph shows a pair of arc flash suits hanging on a wall ready for electricians to use while working on circuit breakers at an electric power generating station:



The blue-colored hood covers the worker’s head and neck, while the grey-colored jumpsuit covers the rest of the worker’s body.

---

<sup>8</sup>A *calorie* is simply another unit of energy measurement. The unit-conversion equivalence is 4.187 Joules per calorie.

The hazards of electrical arcs are not limited to bodily burns. Given sufficient arc power, the explosive expansion of hot air and the shrapnel created by disintegrating hardware represents its own unique hazard, known as *arc blast*. As an *electrically-driven* explosion<sup>9</sup>, arc blast is limited only by the available power of the fault, and can in fact be more violent than a chemical explosion. No suit can ensure safety against arc blast, and so the only reasonable precaution is maintaining a safe distance beyond the blast radius.

---

<sup>9</sup>The concussive effects of an arc blast originate from the rapid expansion of air and vaporized metal, producing intense sound waves and blast pressures. Extremely bright light, as well as high temperatures caused by convection of super-heated air and by radiation of infrared light from the arc are capable of creating third-degree burns on unprotected skin.



## Chapter 5

# Animations

Some concepts are much easier to grasp when seen in *action*. A simple yet effective form of animation suitable to an electronic document such as this is a “flip-book” animation where a set of pages in the document show successive frames of a simple animation. Such “flip-book” animations are designed to be viewed by paging forward (and/or back) with the document-reading software application, watching it frame-by-frame. Unlike video which may be difficult to pause at certain moments, “flip-book” animations lend themselves very well to individual frame viewing.

## 5.1 Rotating magnetic field animated

The following animation shows how the “rotating” magnetic field of a three-phase AC induction motor is produced by the interaction of three stator winding sets energized with different phases (A, B, and C) of a three-phase AC power source. A red arrow shows the direction of the *resultant* magnetic field created by the interaction of the three winding sets.

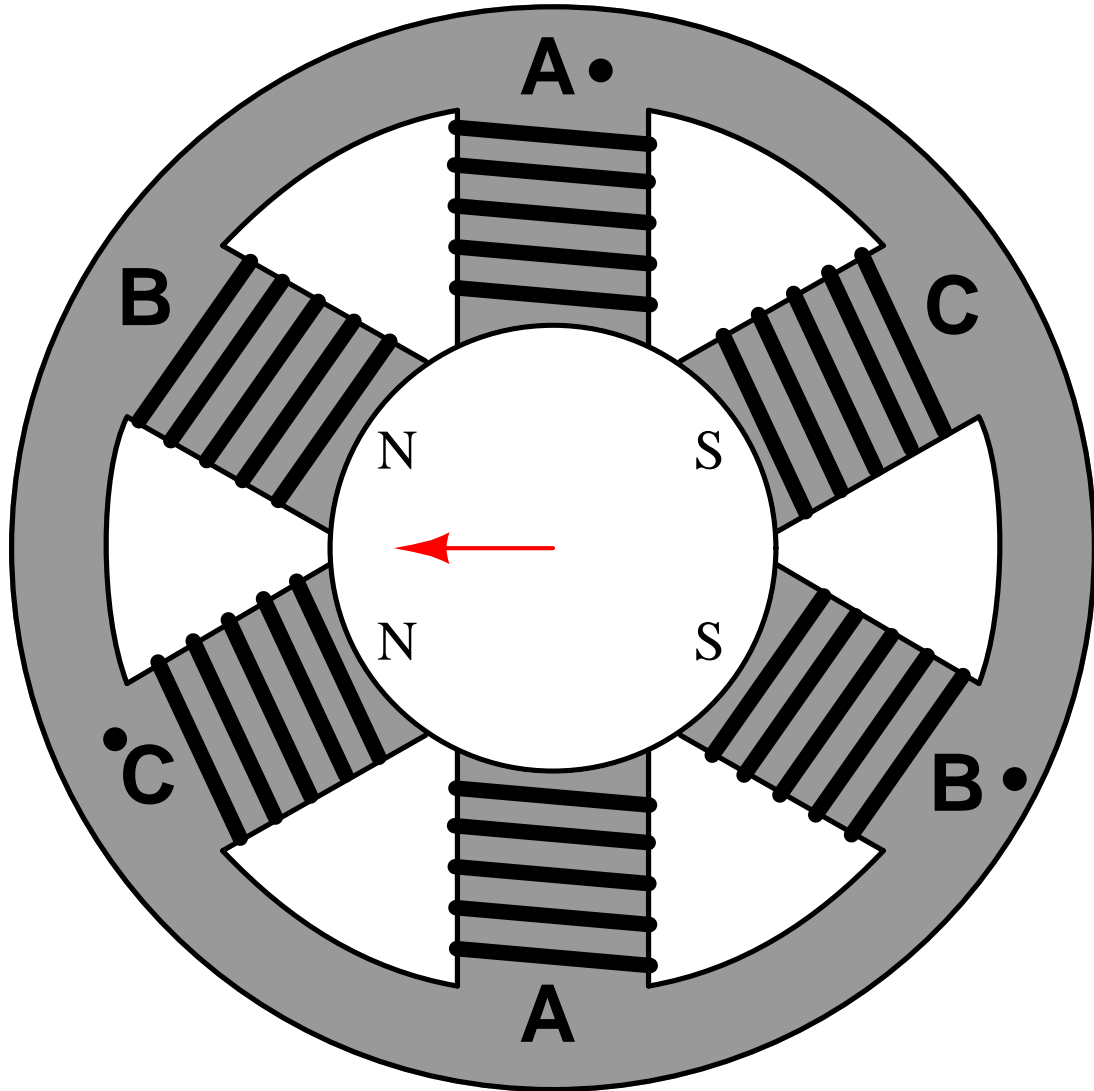

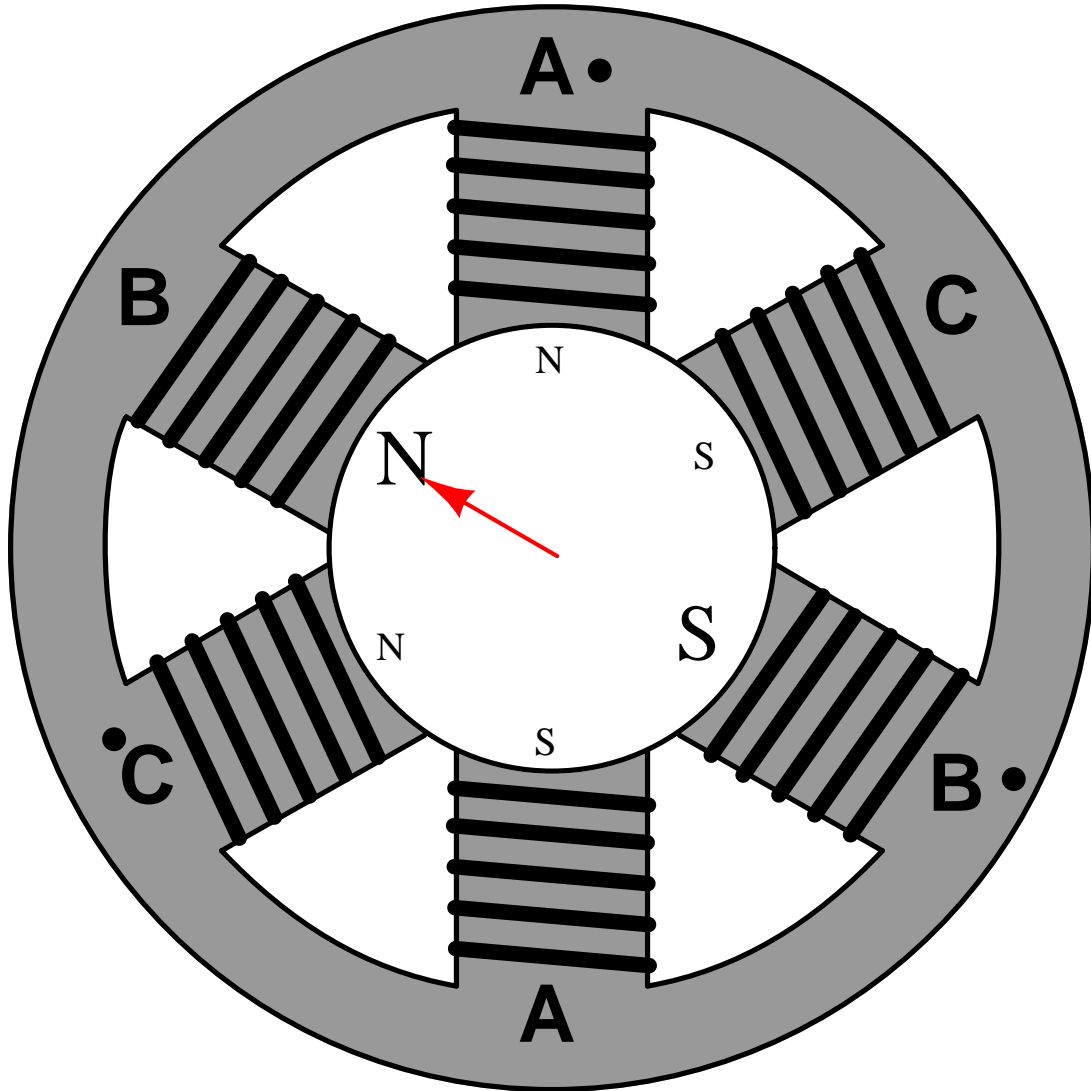

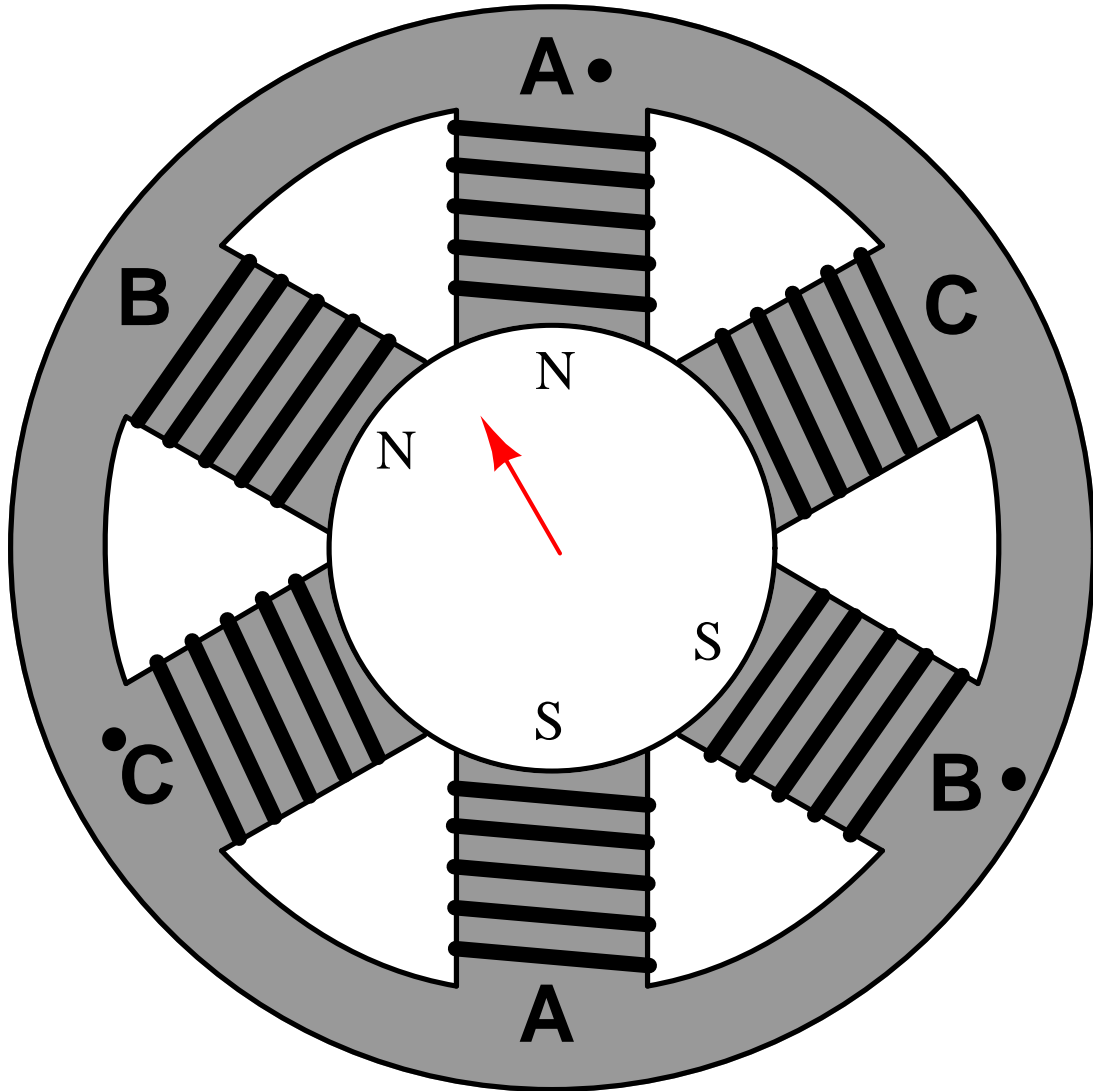



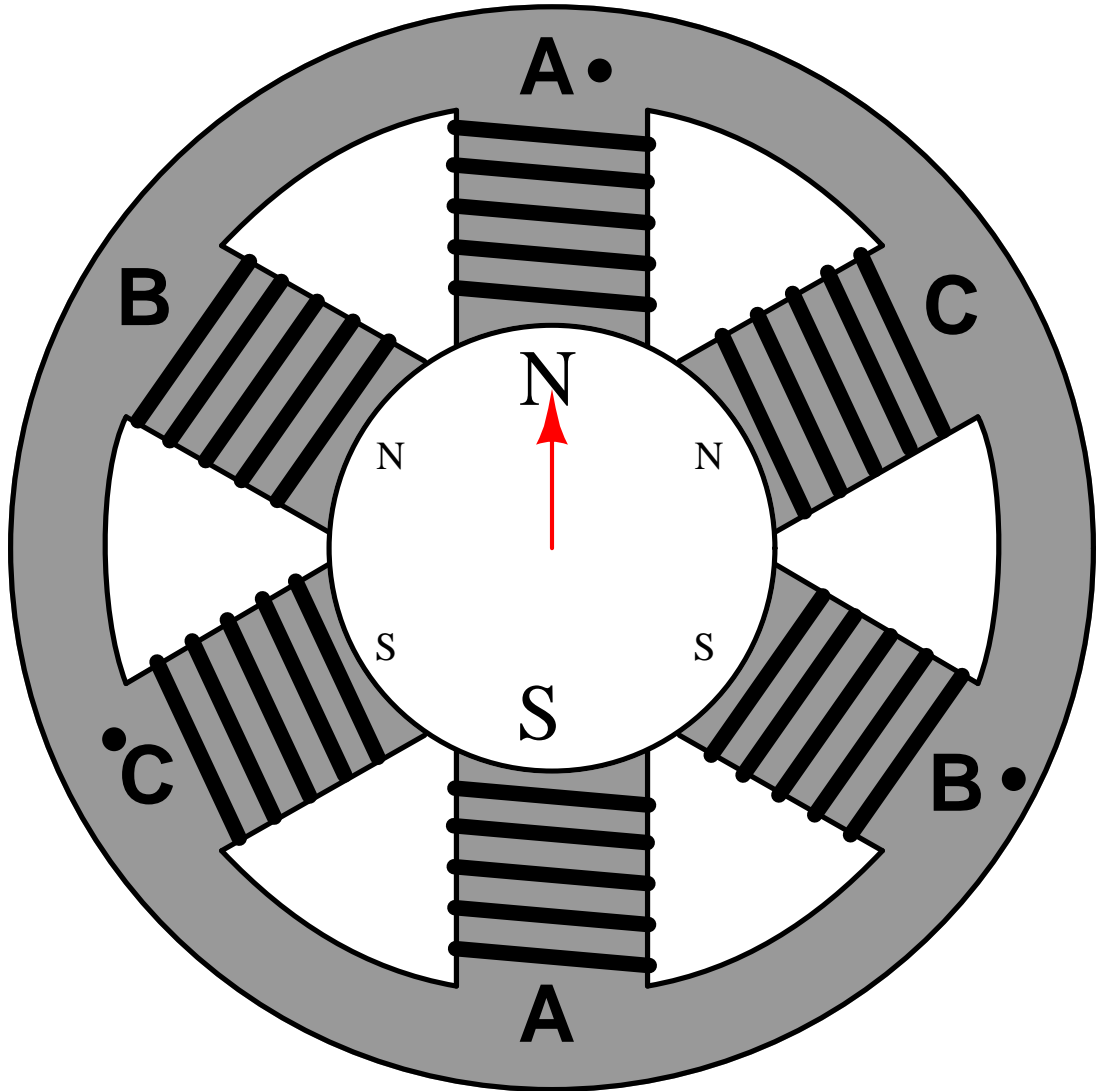

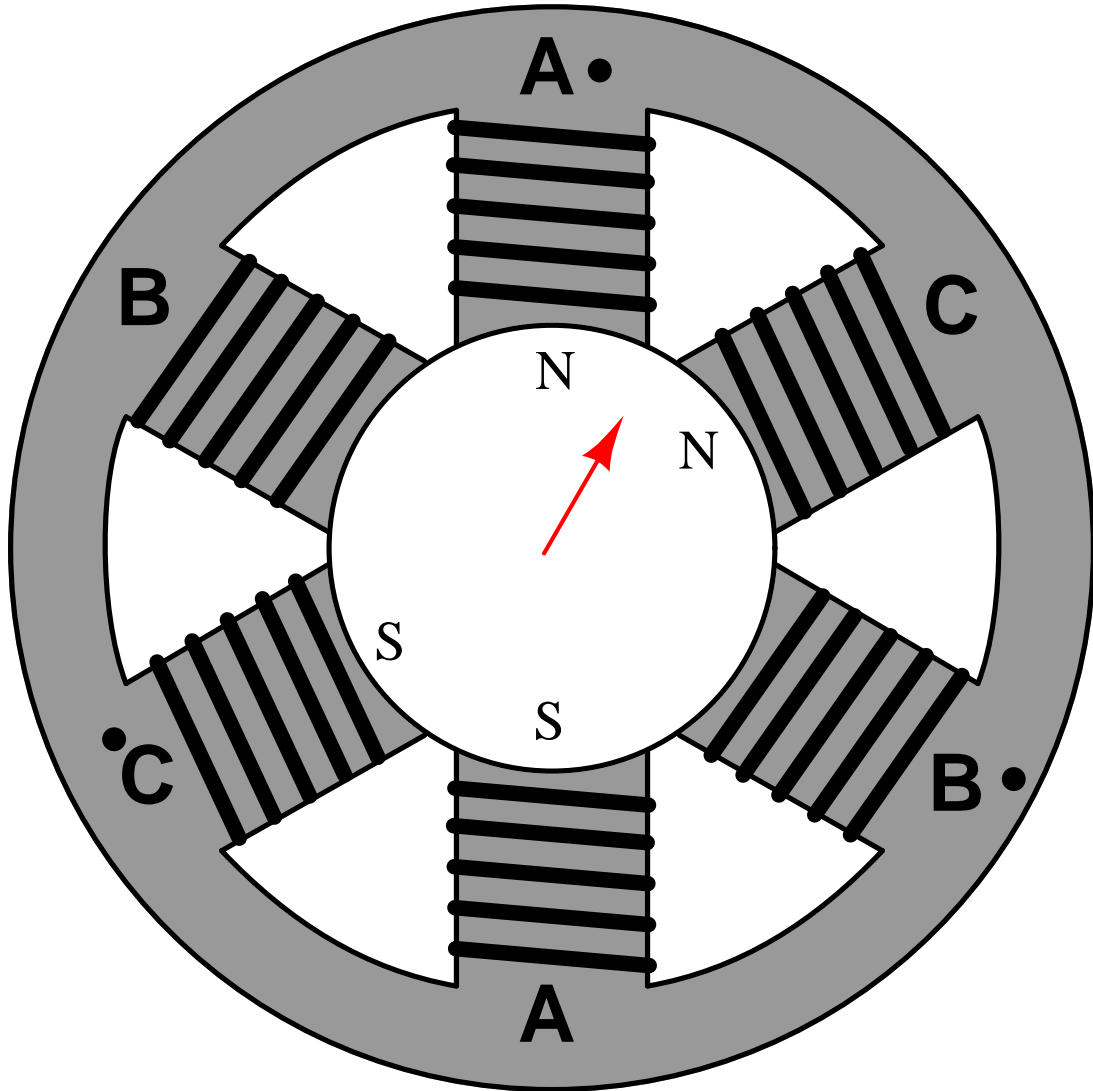

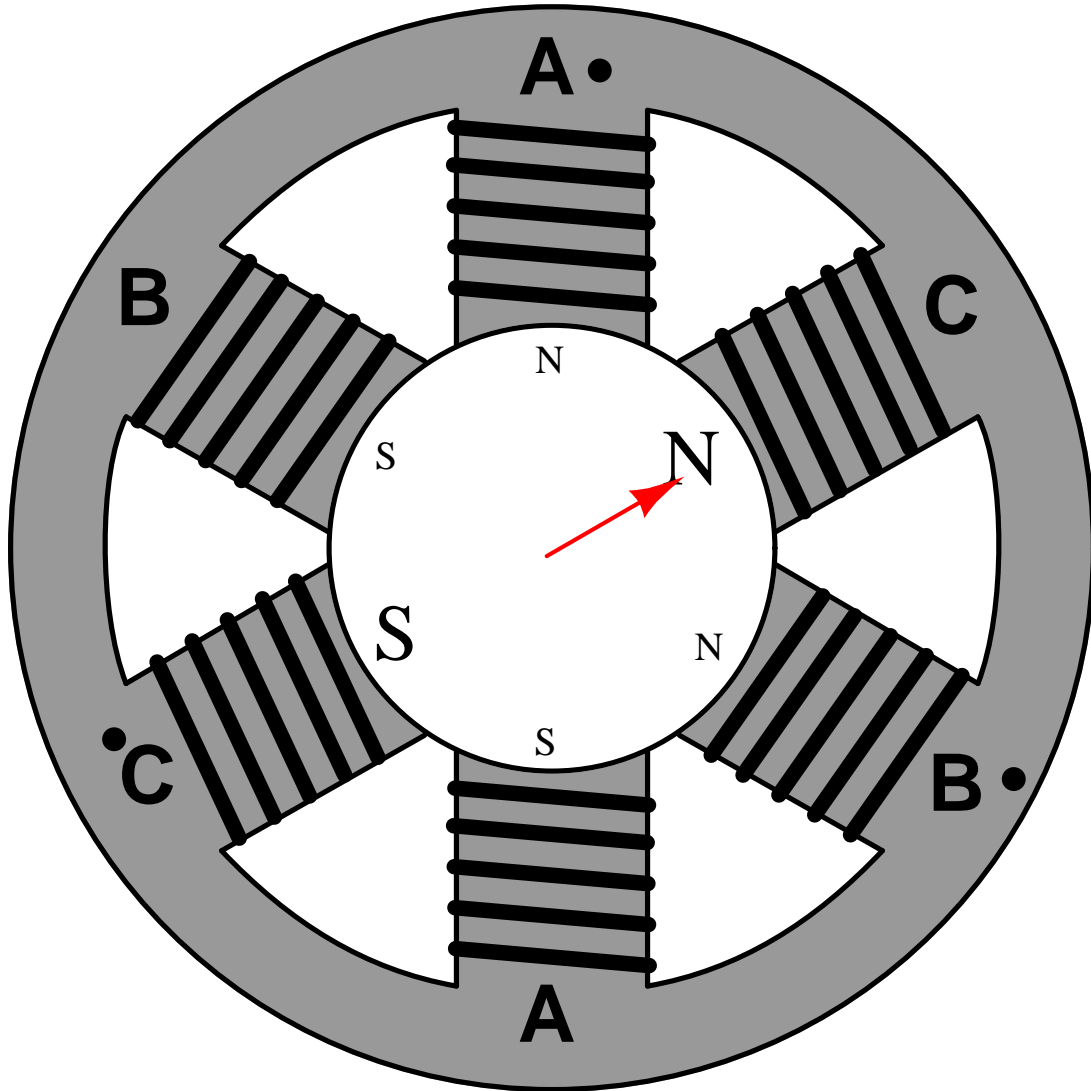

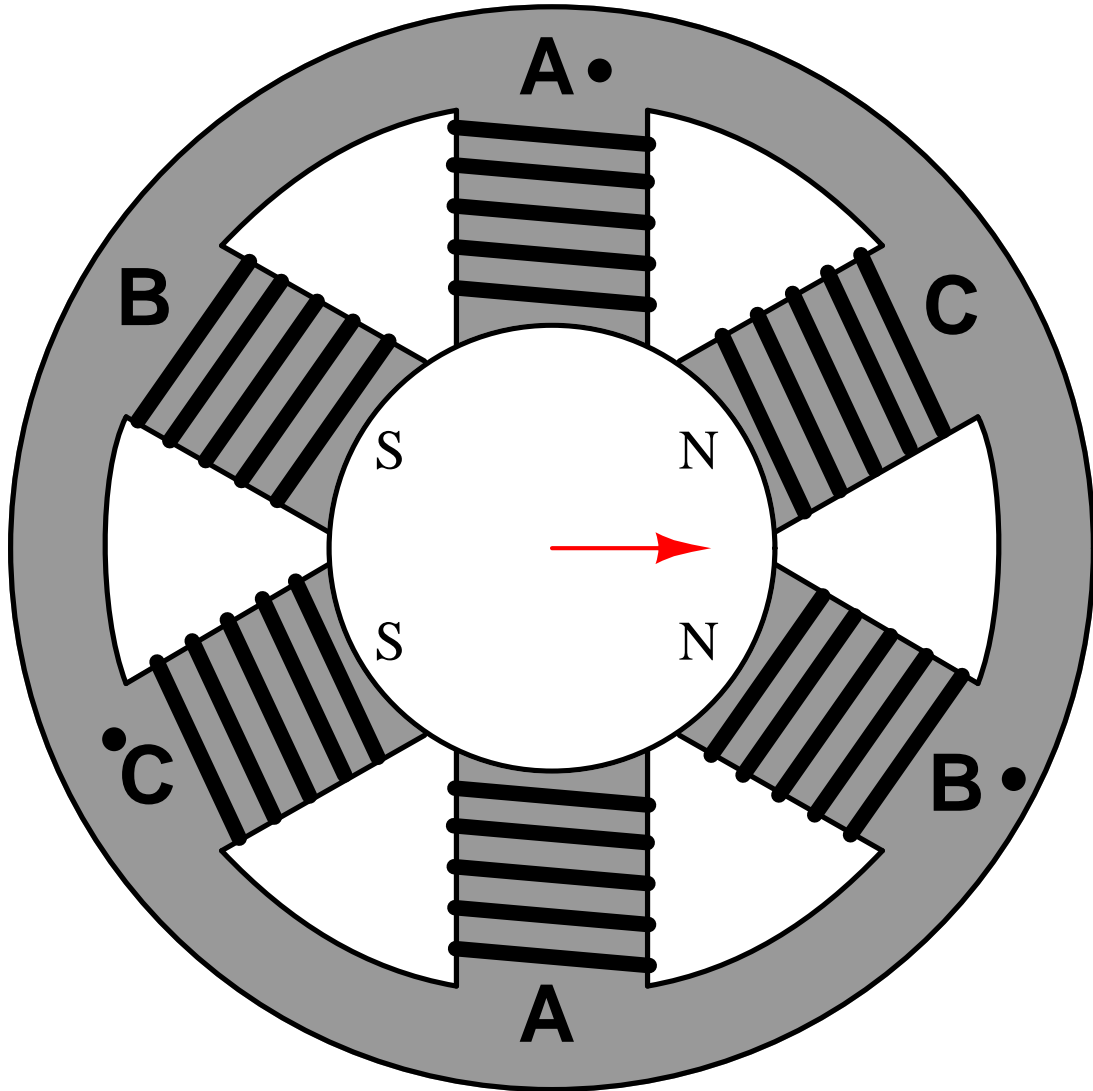

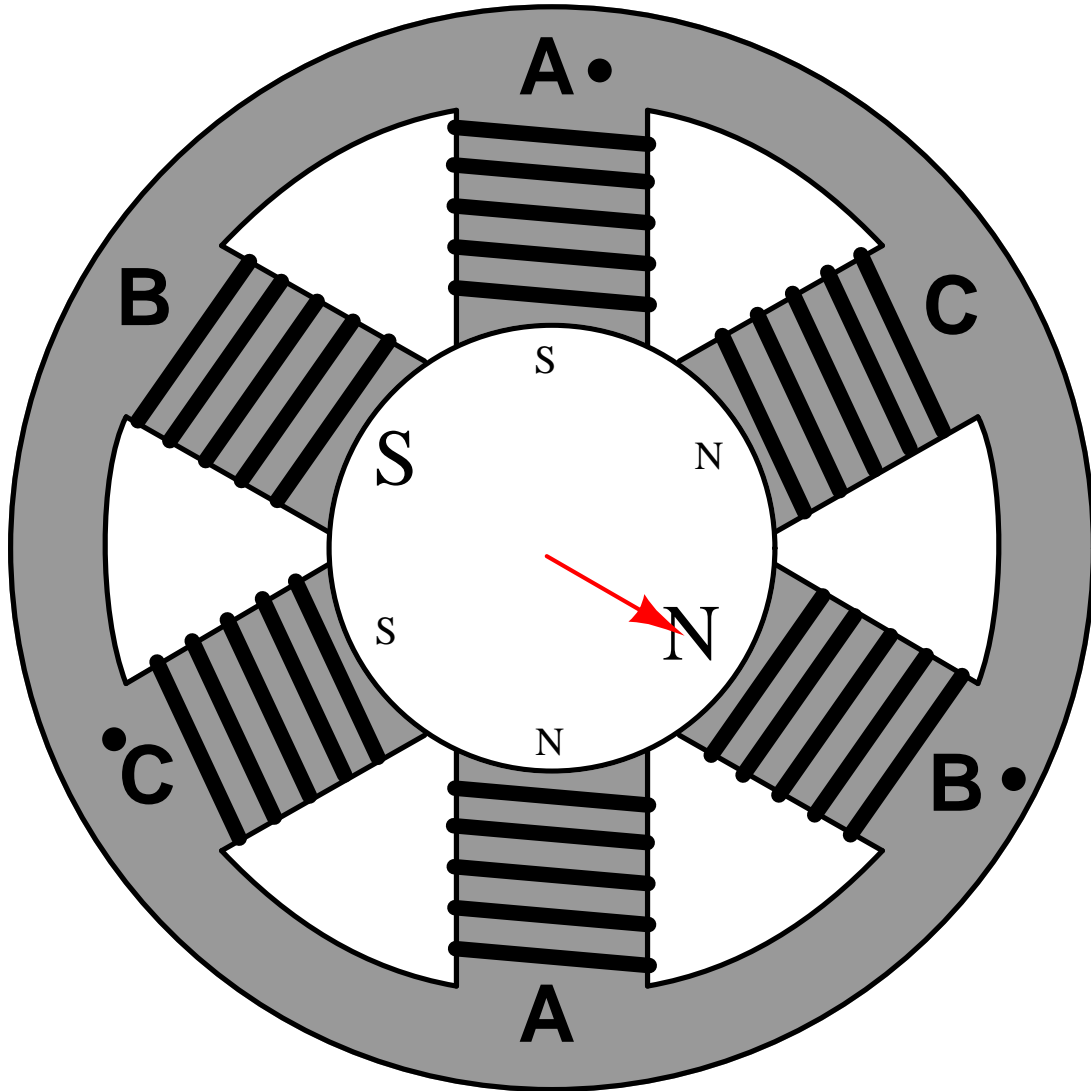

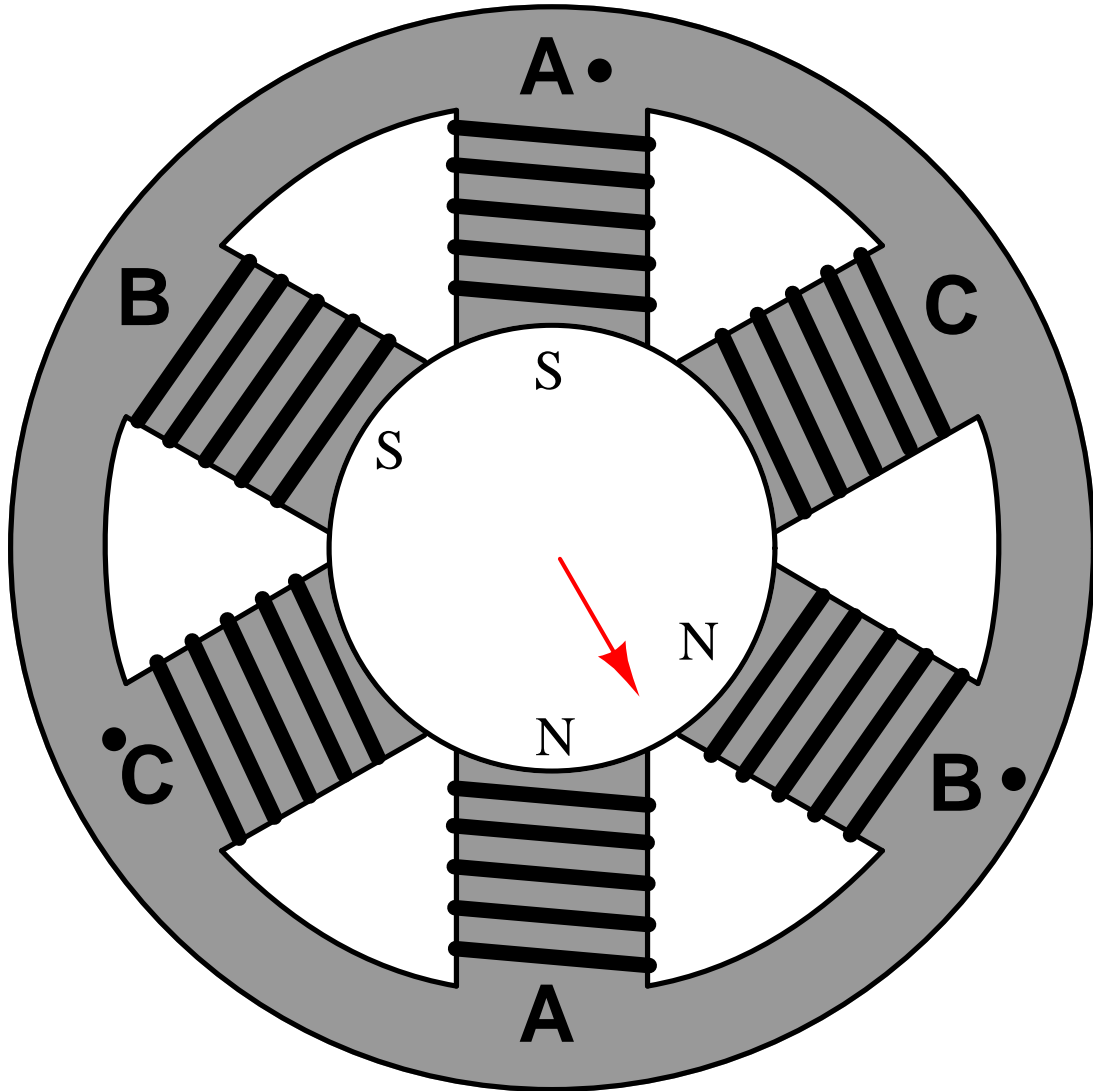

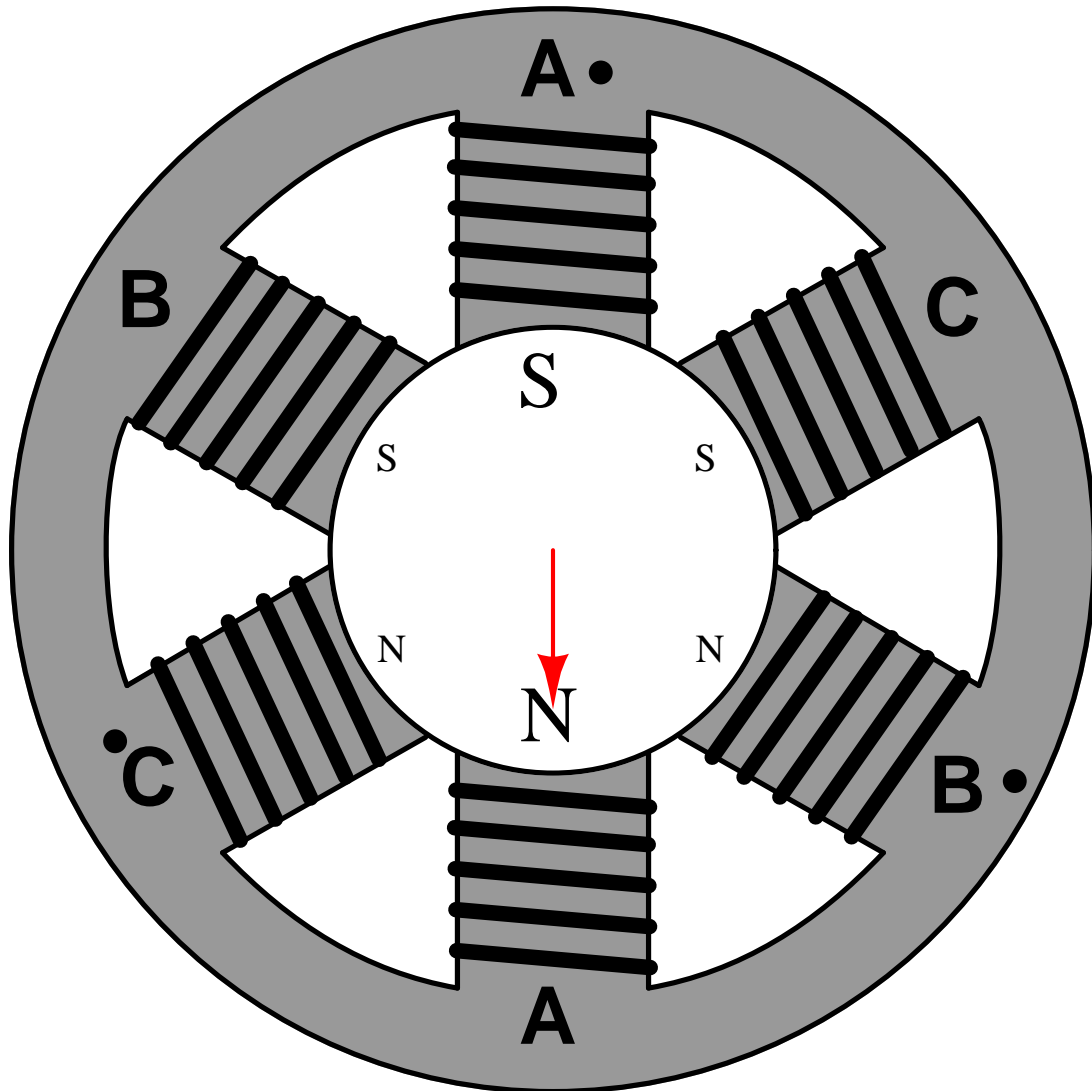

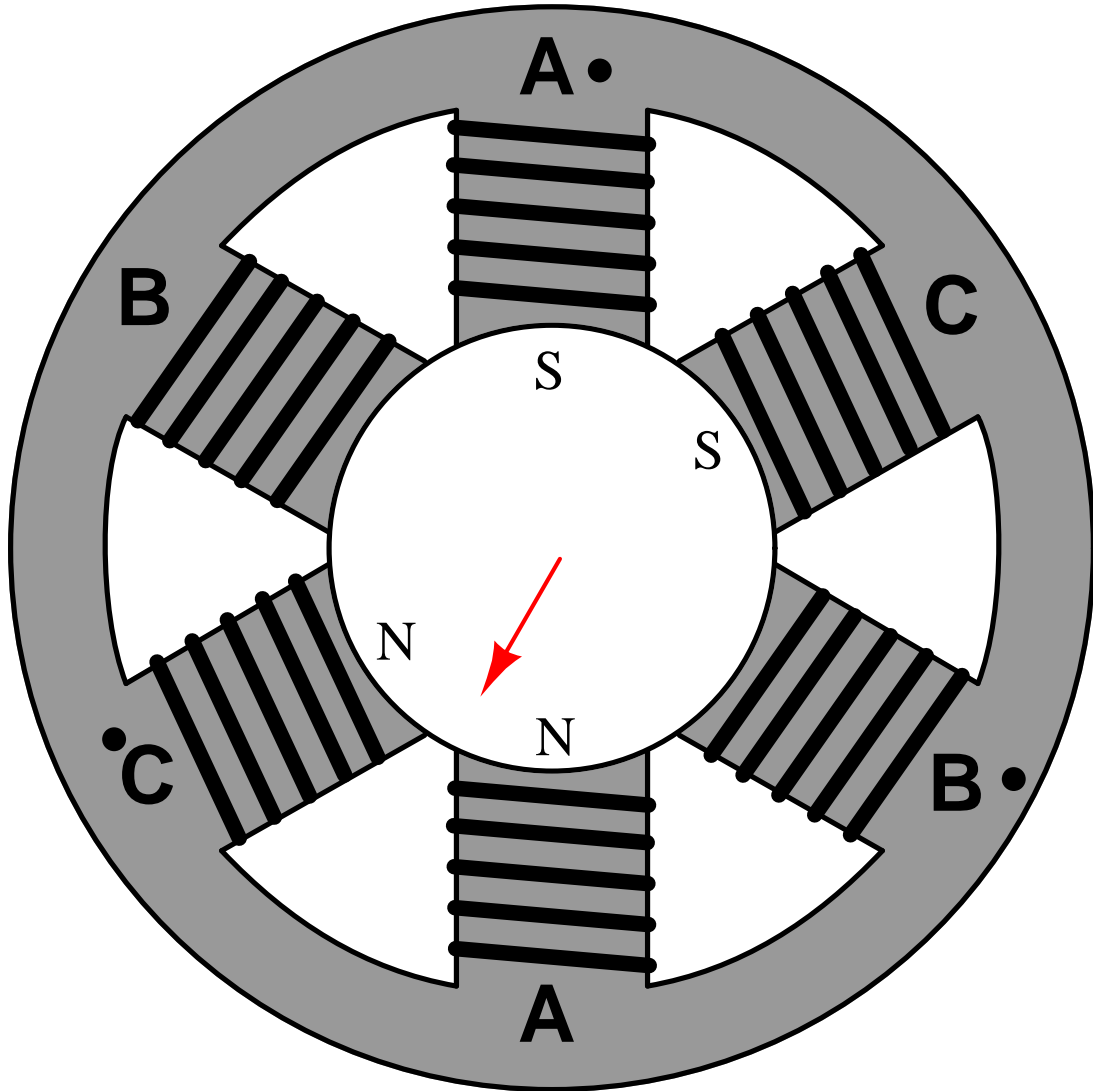



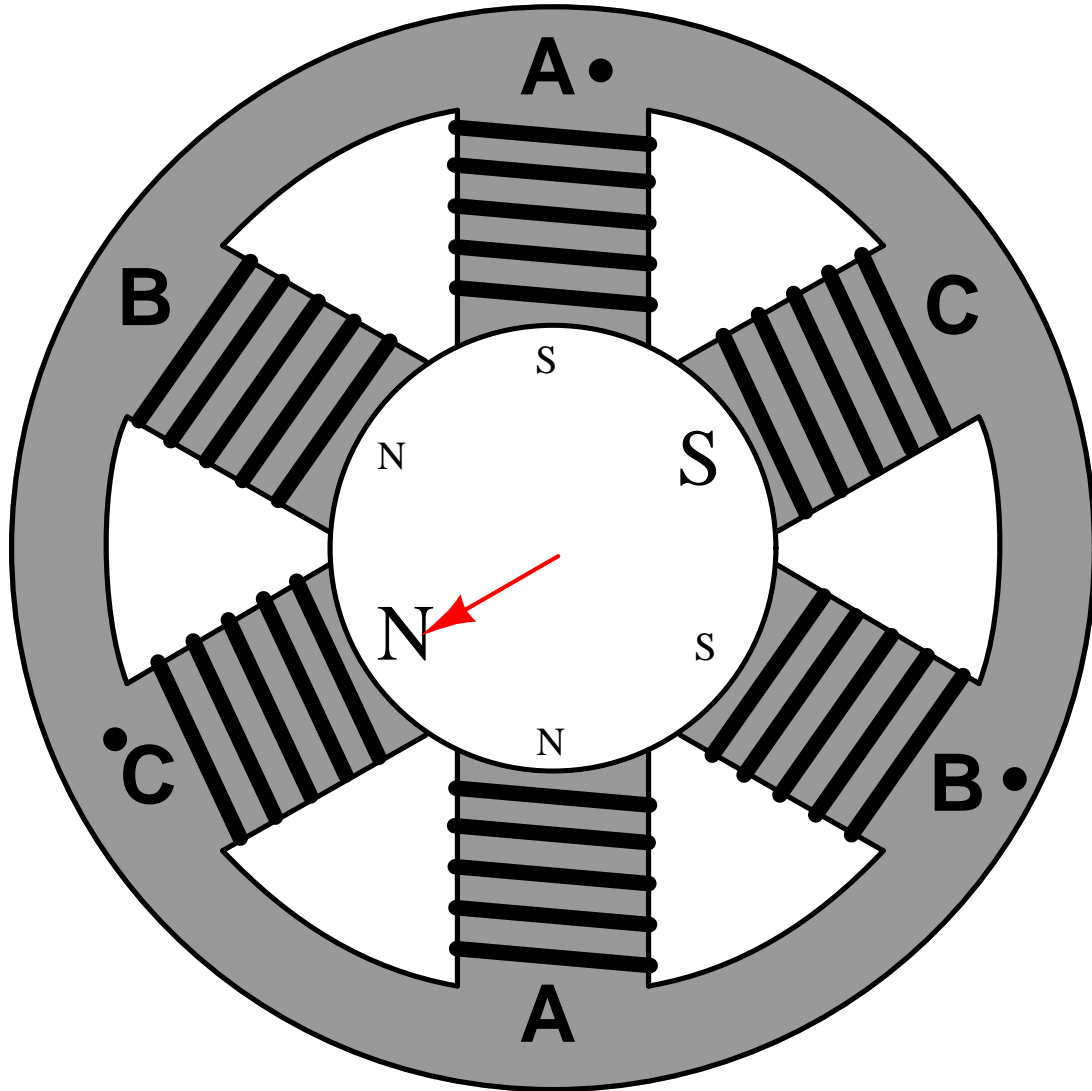

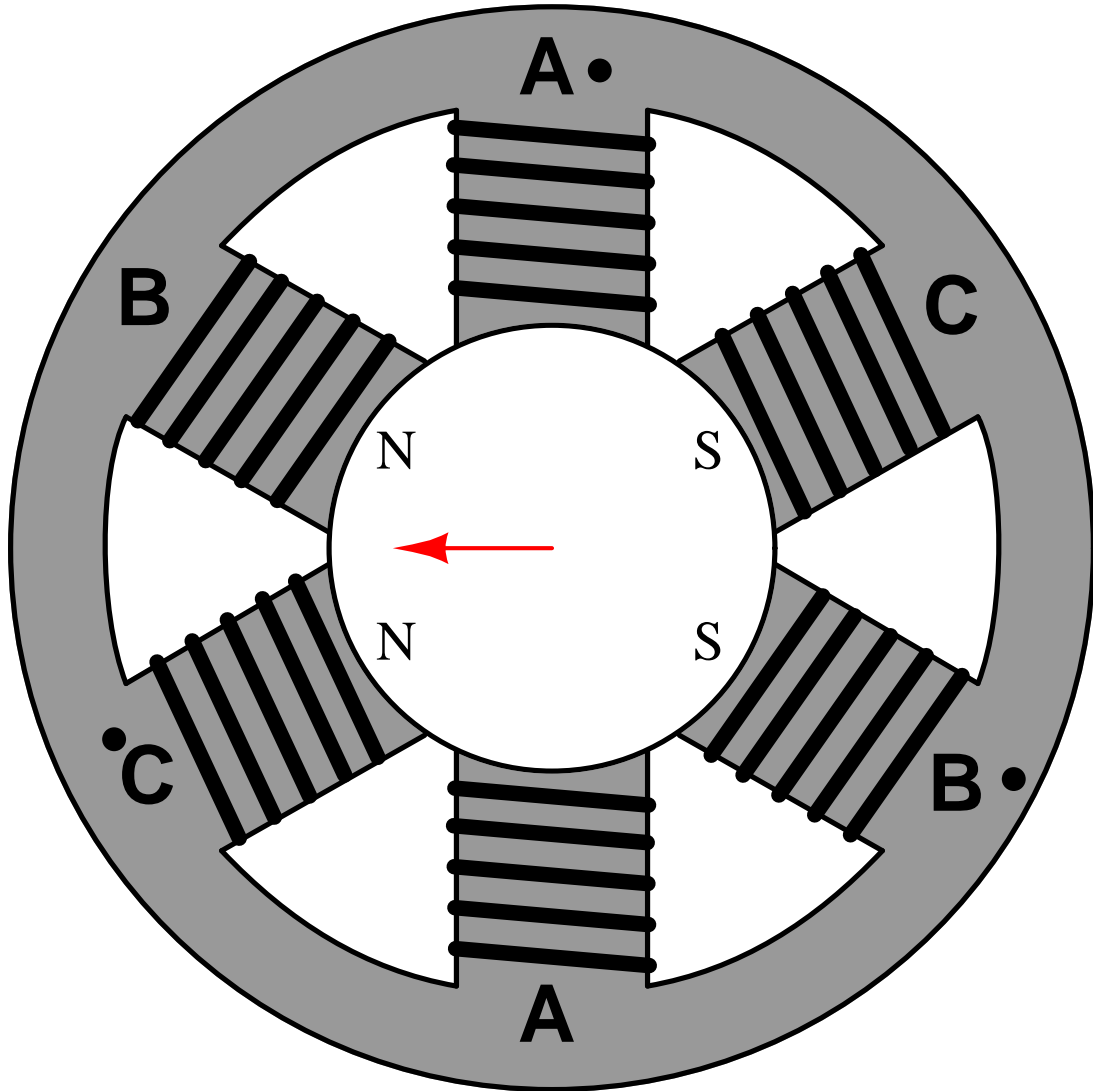

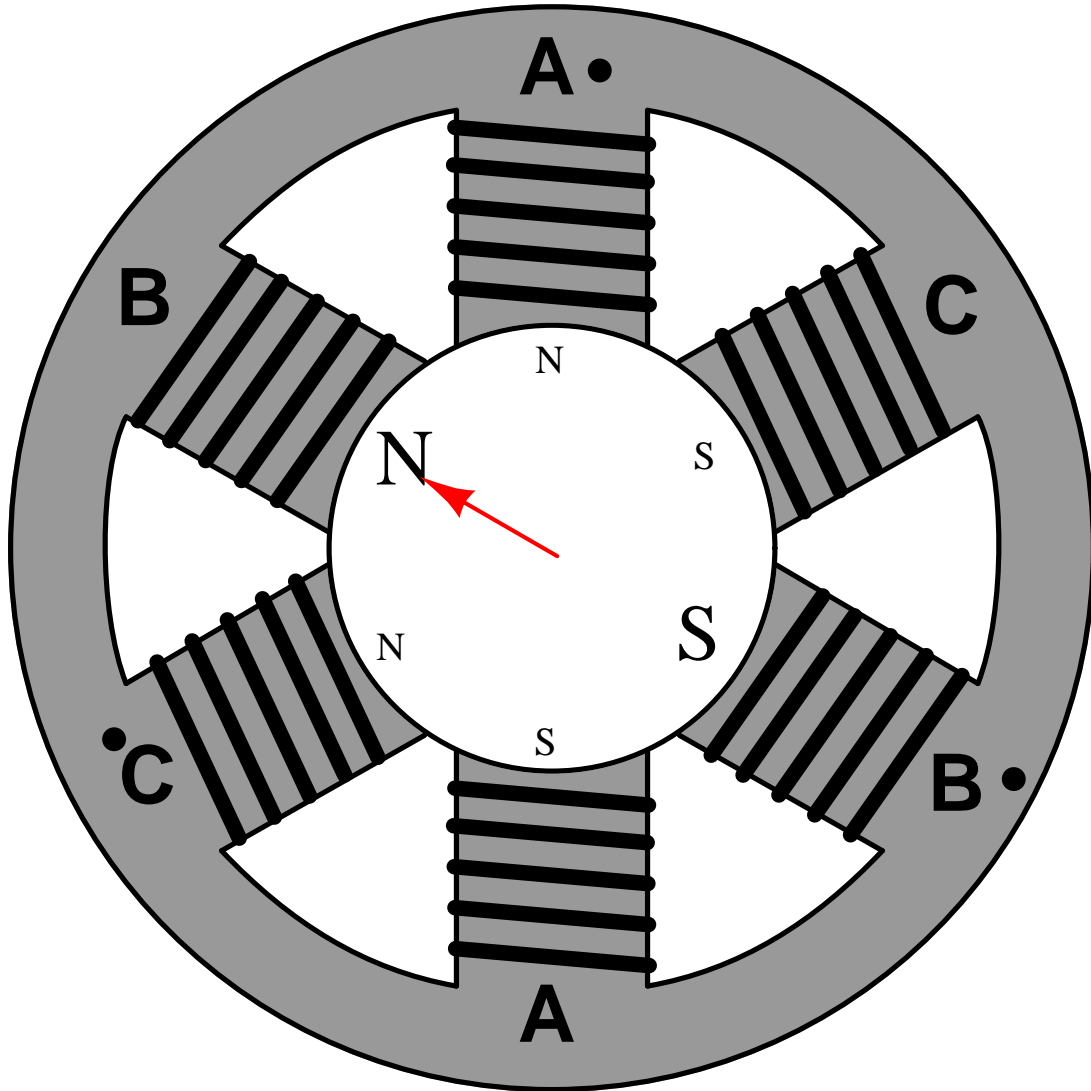

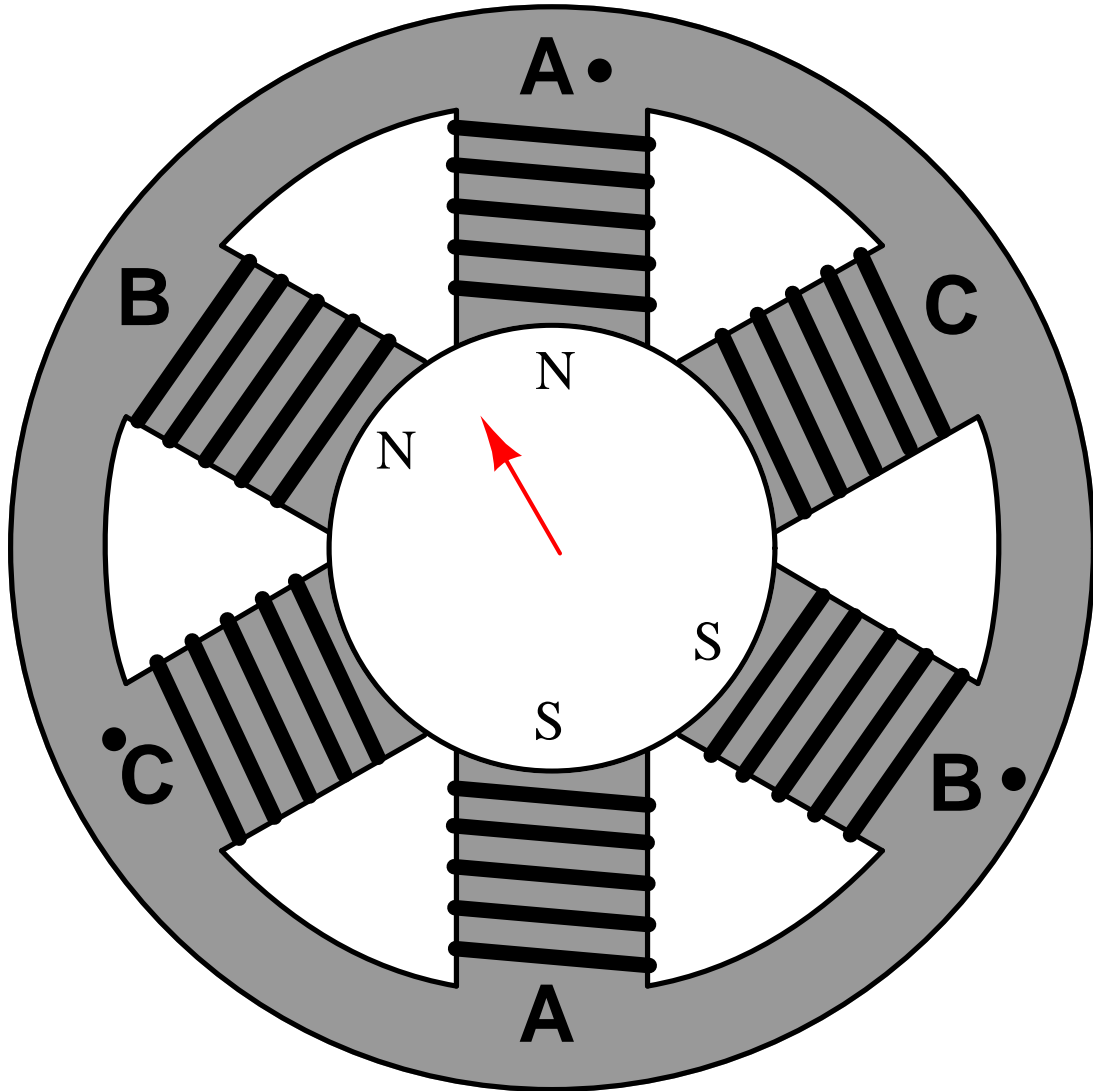

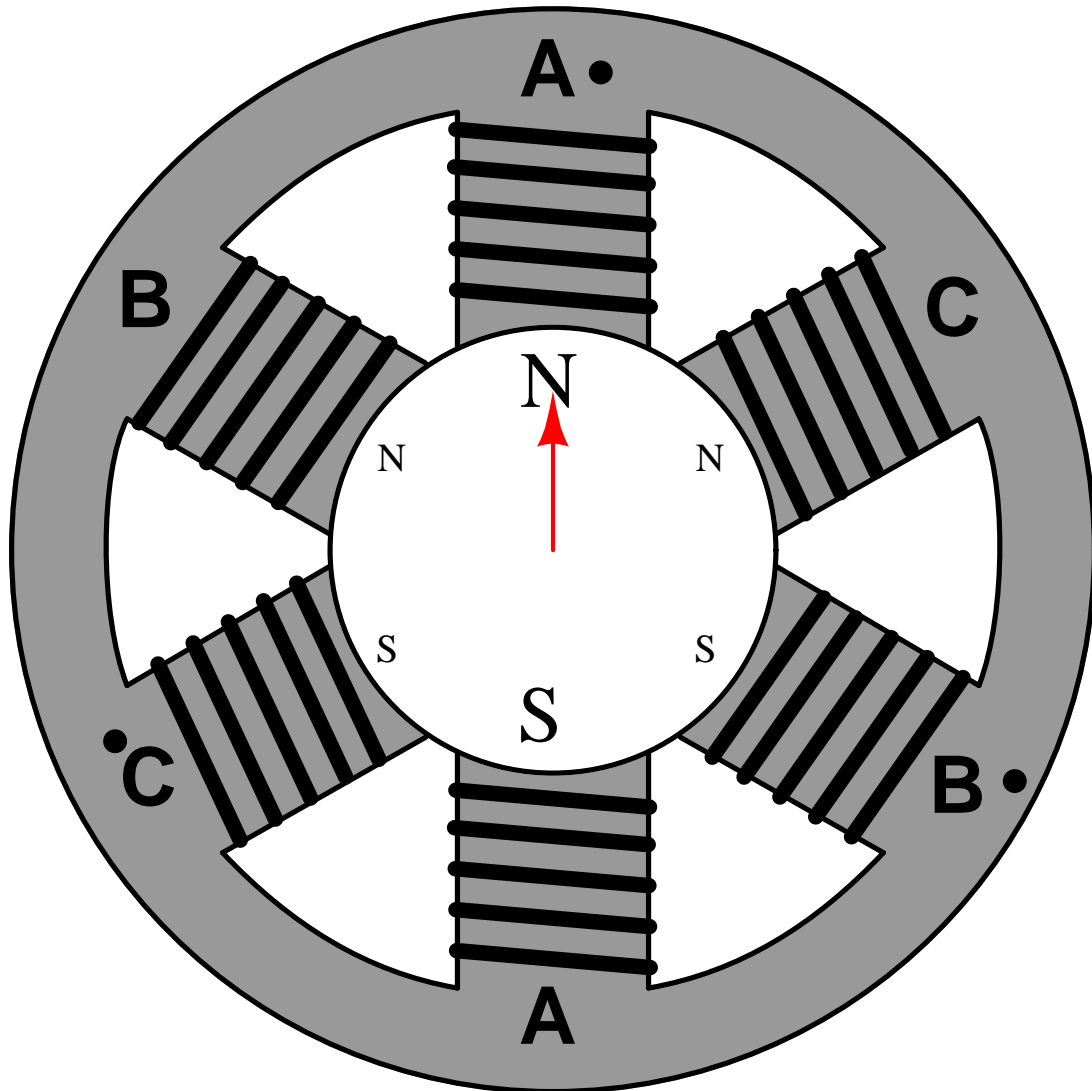

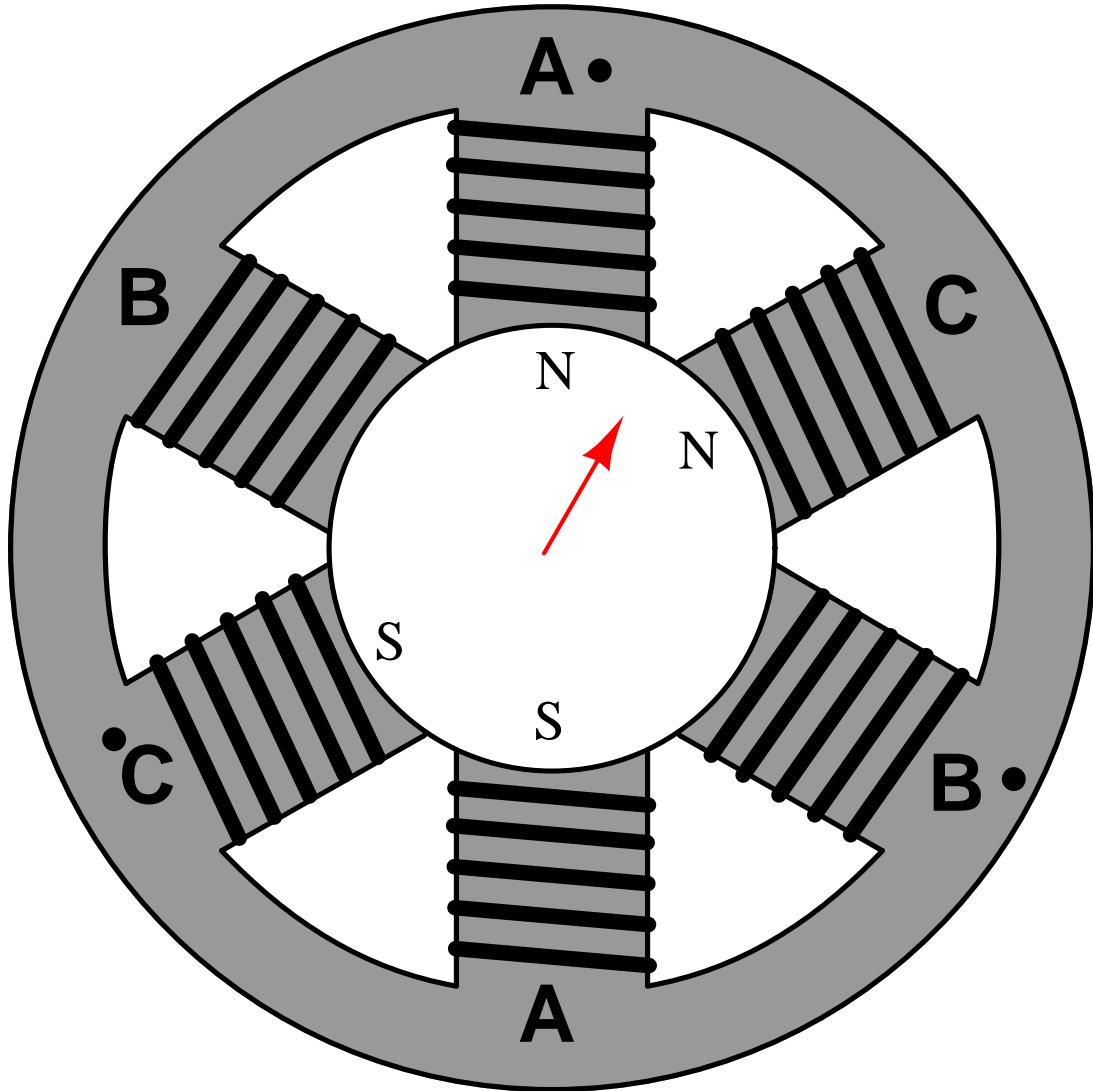

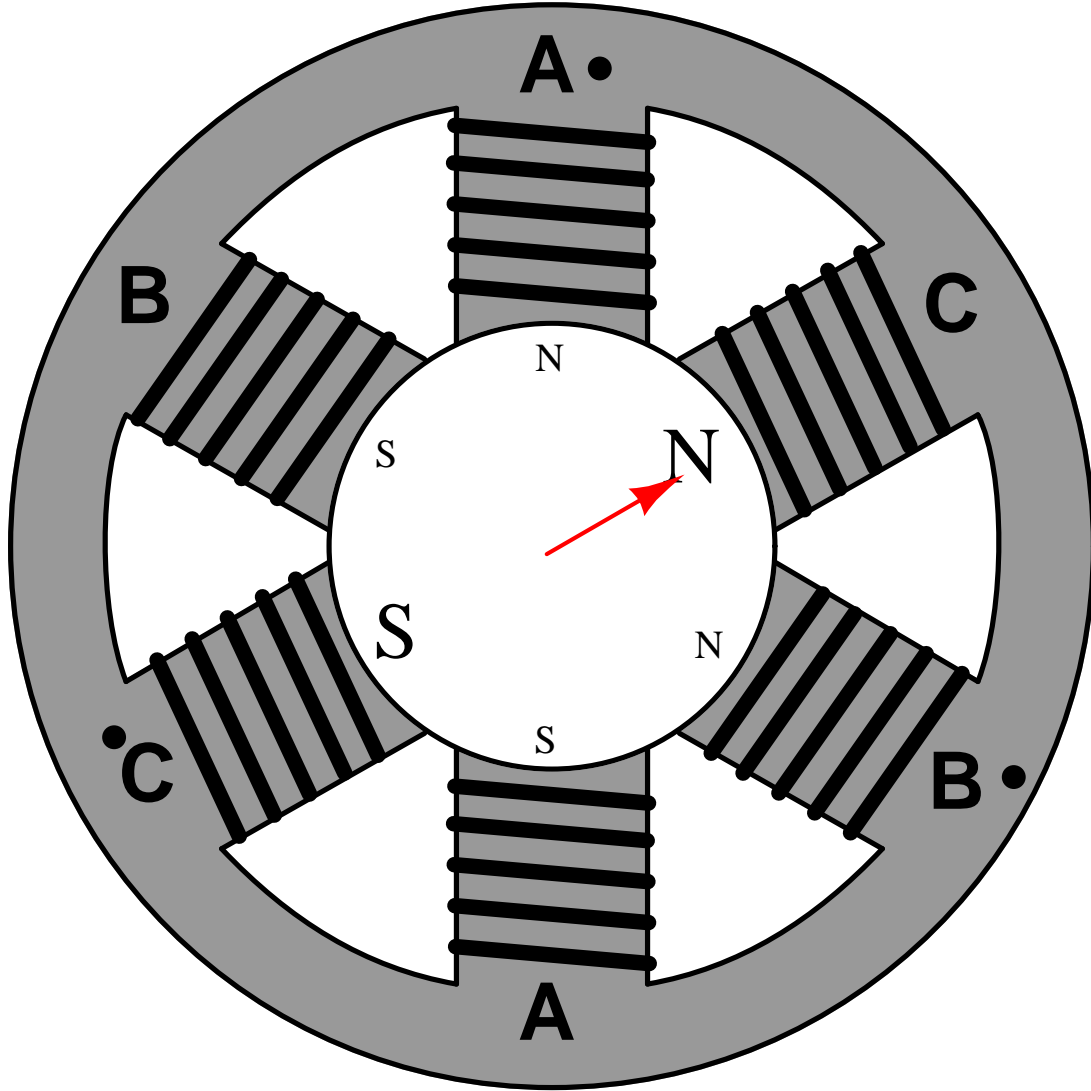

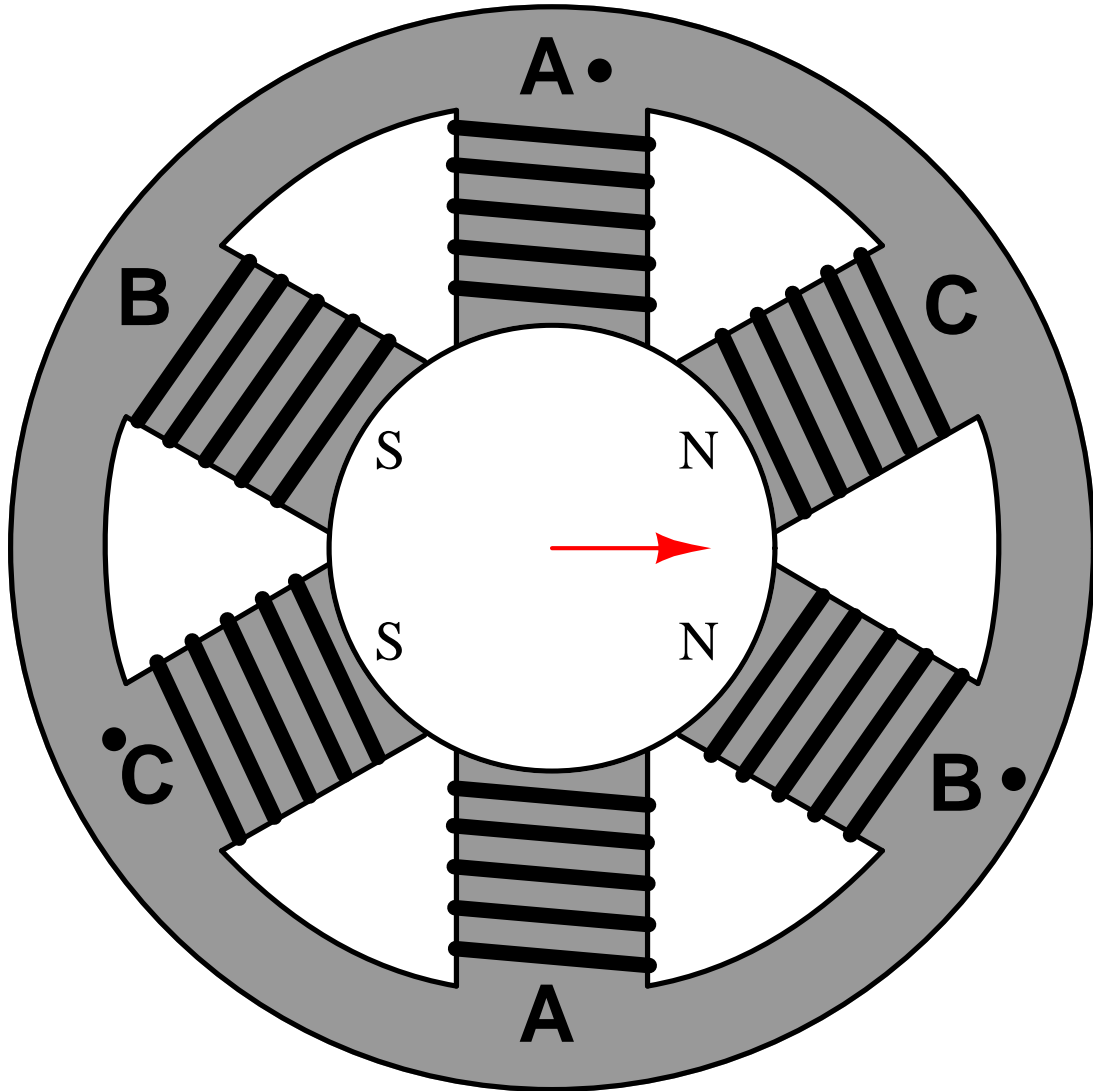



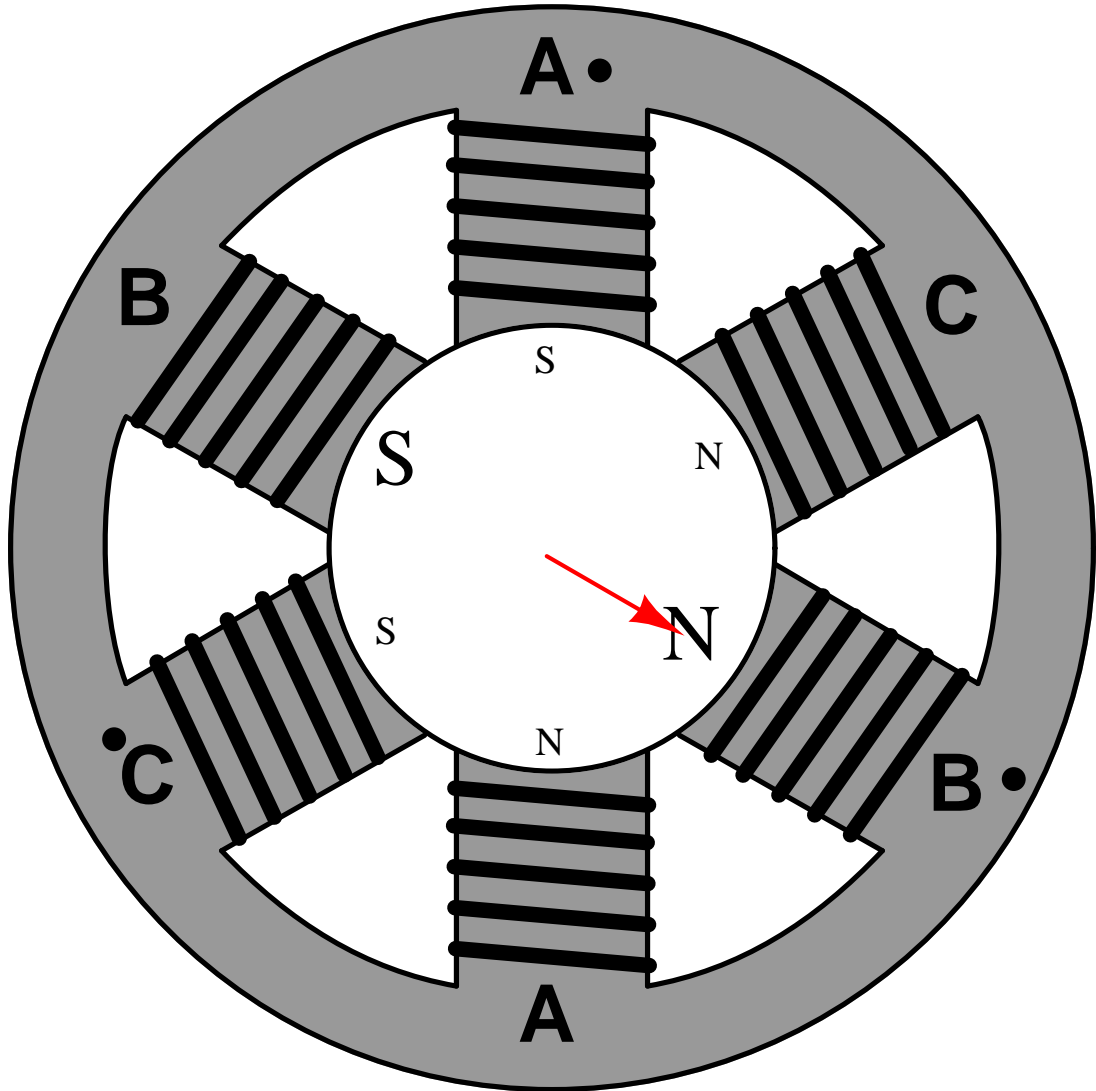

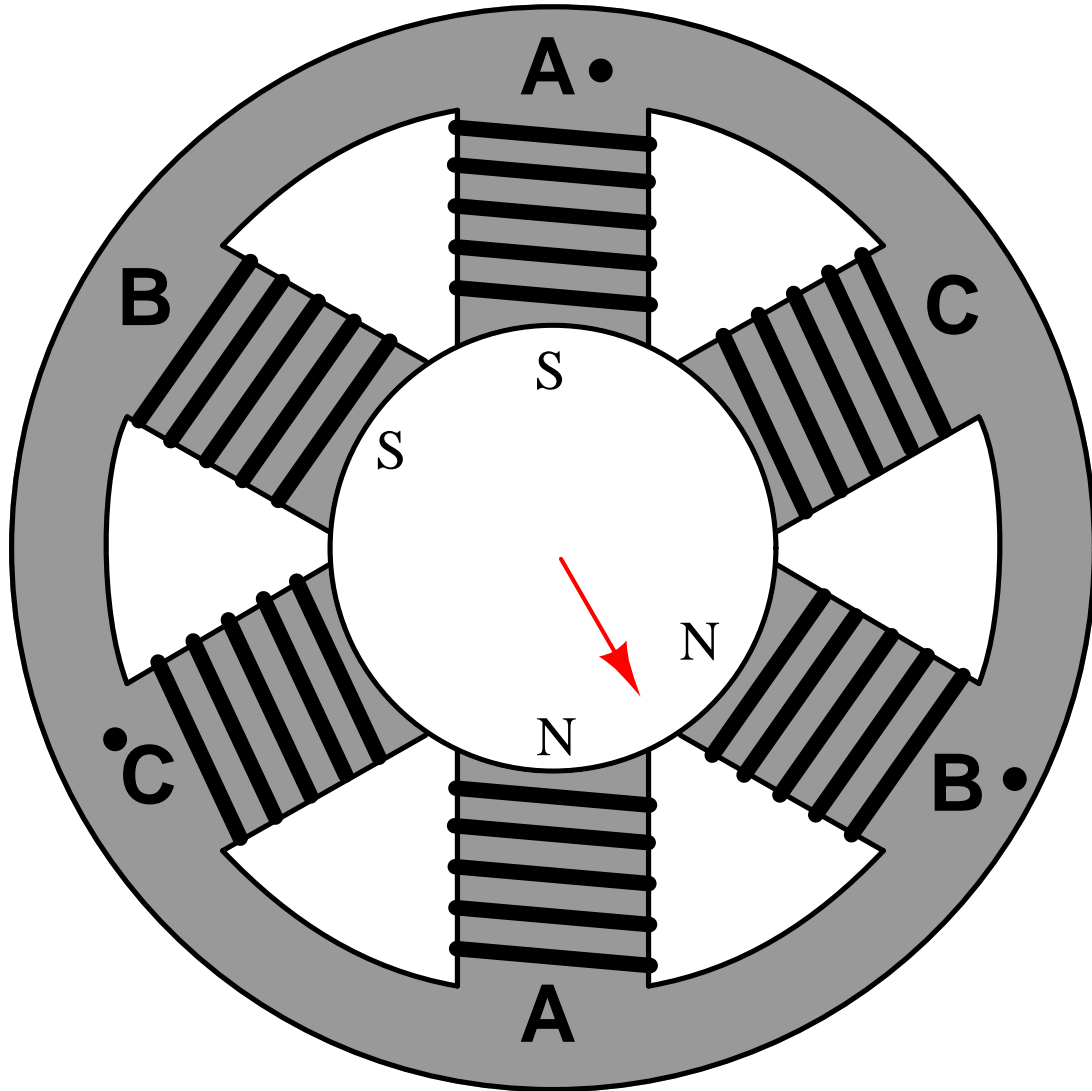

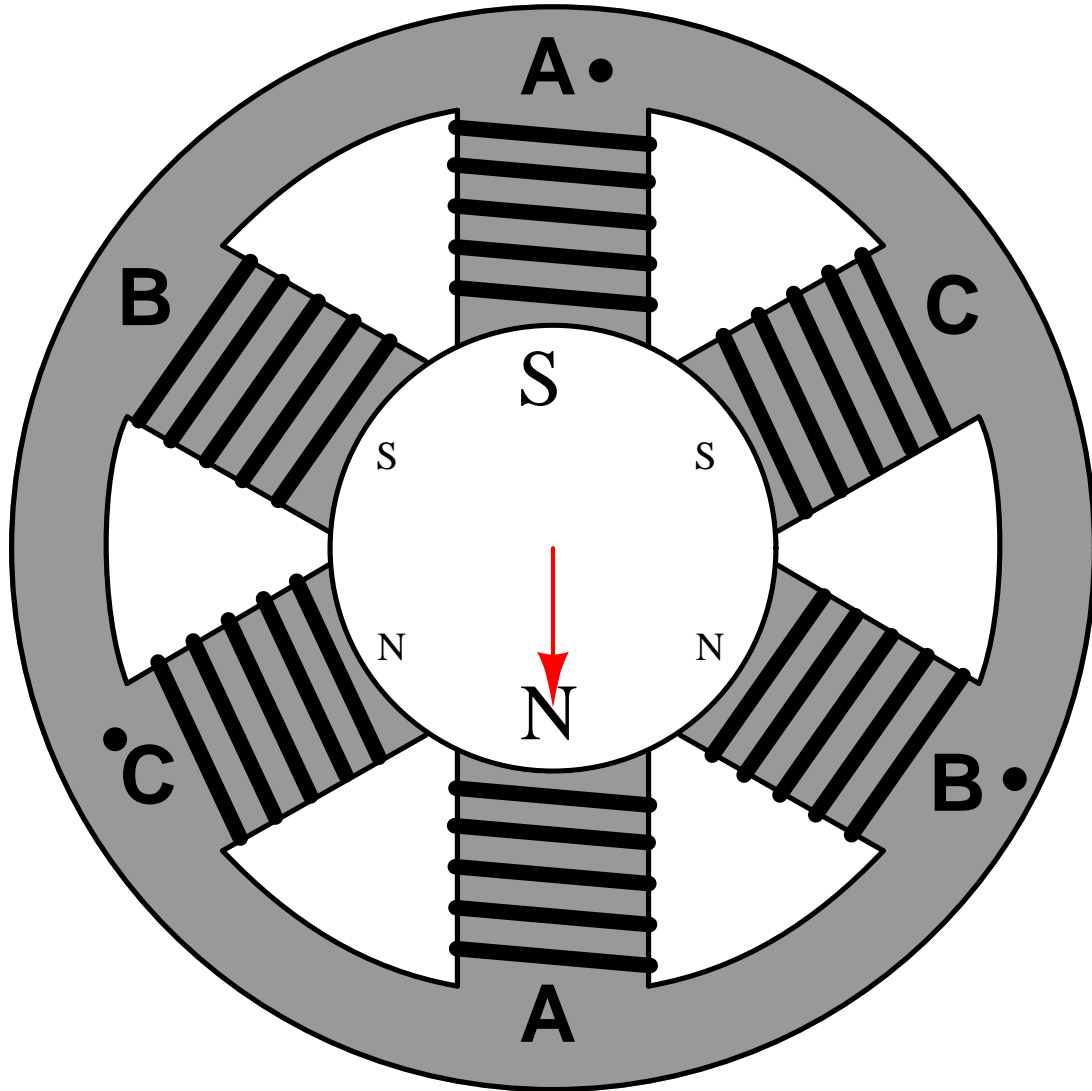

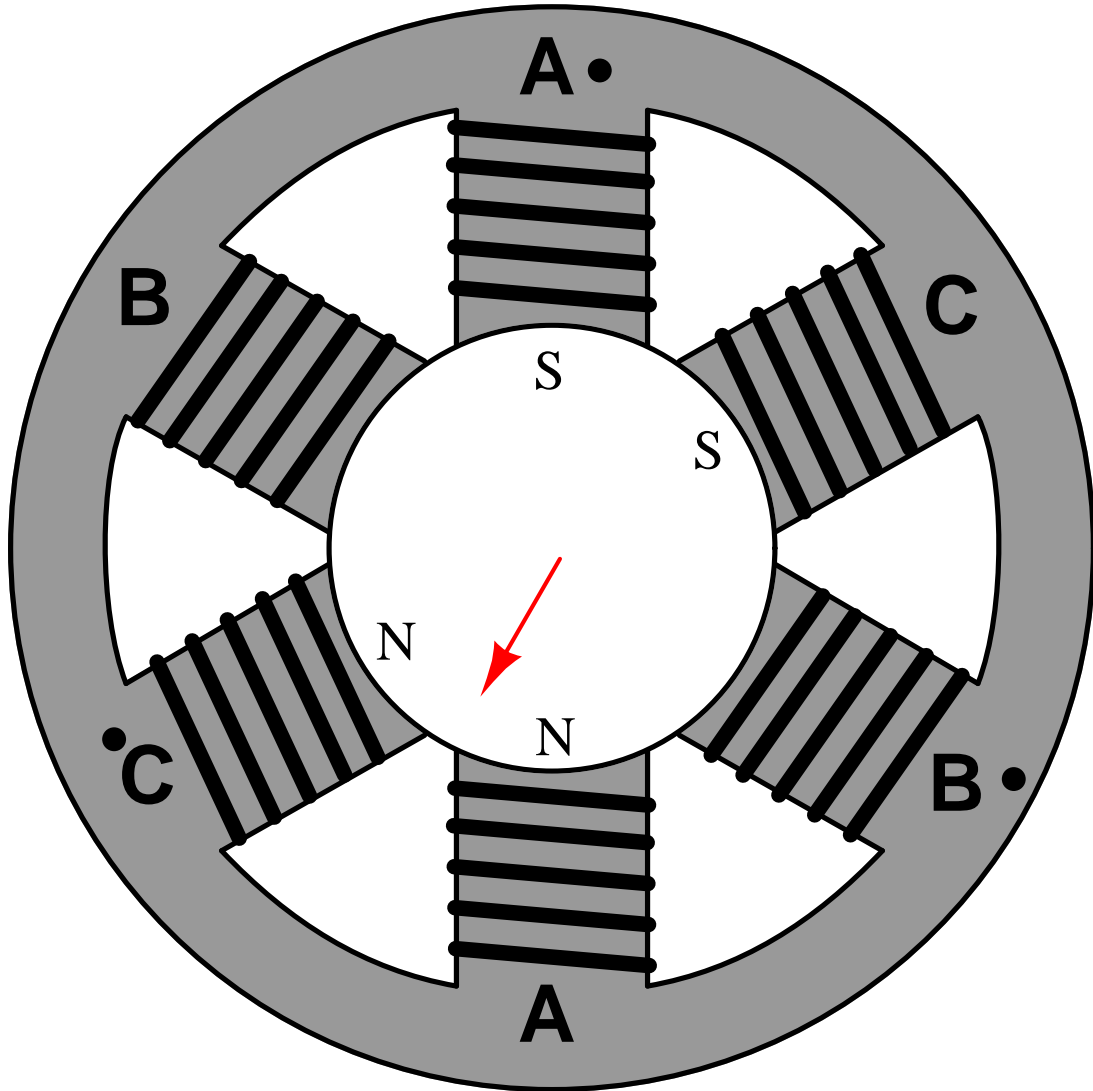

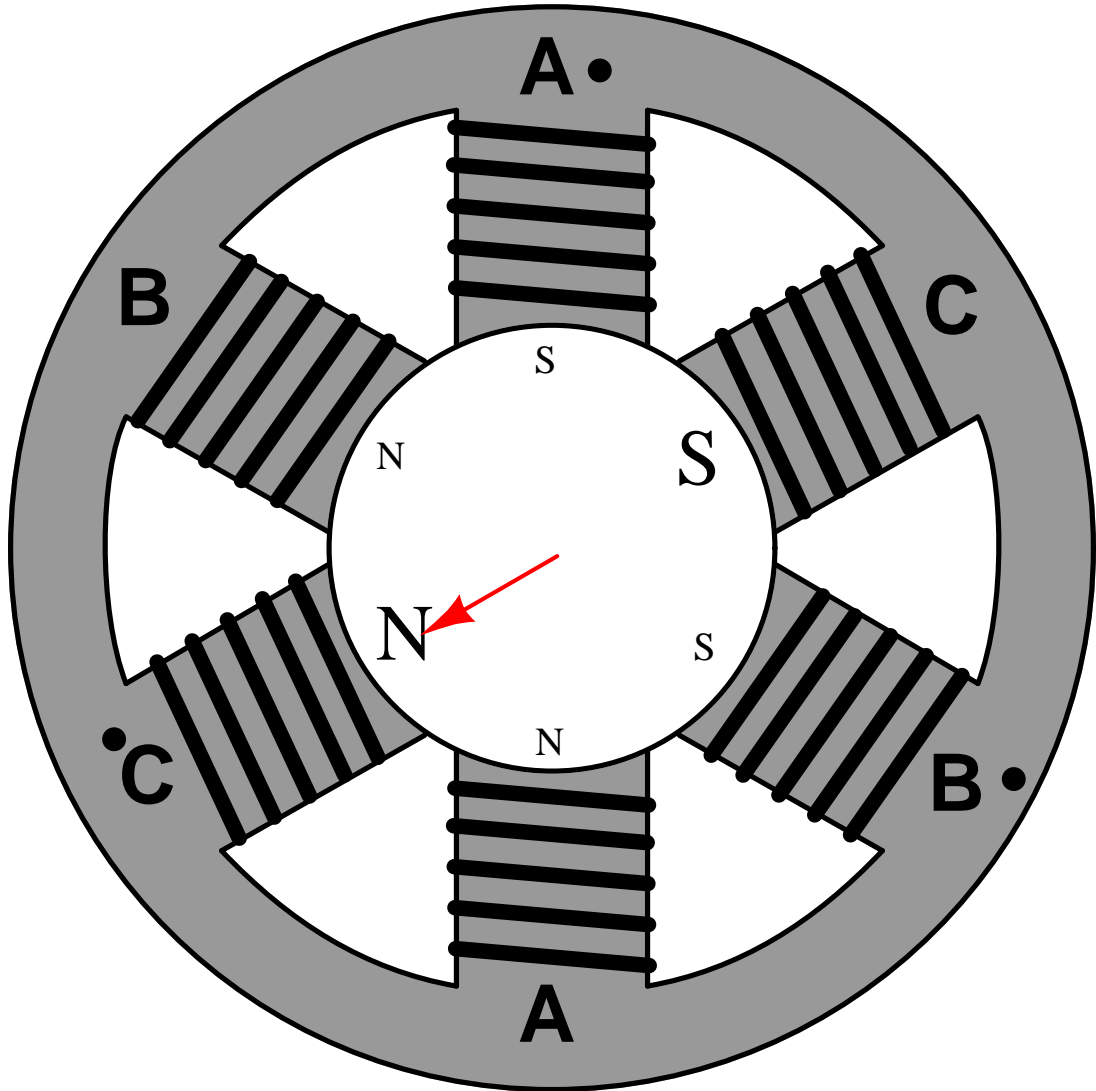

## 5.2 VFD transistor switching sequence

The following animation shows how the “rotating” magnetic field of a three-phase AC induction motor is produced by the interaction of three stator winding sets energized with different phases (A, B, and C) of a three-phase AC power source. A red arrow shows the direction of the *resultant* magnetic field created by the interaction of the three winding sets.

A VFD’s power circuitry consists of a *rectifier* section to convert AC into DC, a *filter* section to “smooth” the DC so that it is more steady than it would be otherwise emerging from the rectifier, and finally an *inverter* section where the filtered DC is converted into three-phase AC at the desired voltage and frequency. In this animation we show the inverter stage’s six transistors turning on and off as necessary to create the rotating magnetic field vector in the motor, but what we do not show is the high-speed pulsing of those transistors within each of their “on” periods necessary to synthesize a *sinusoidal* output current.

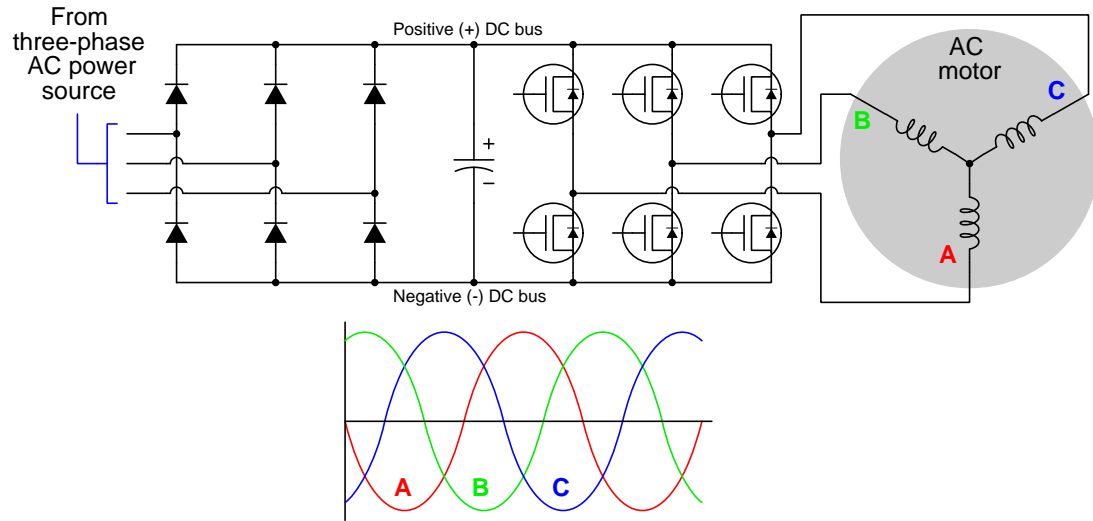

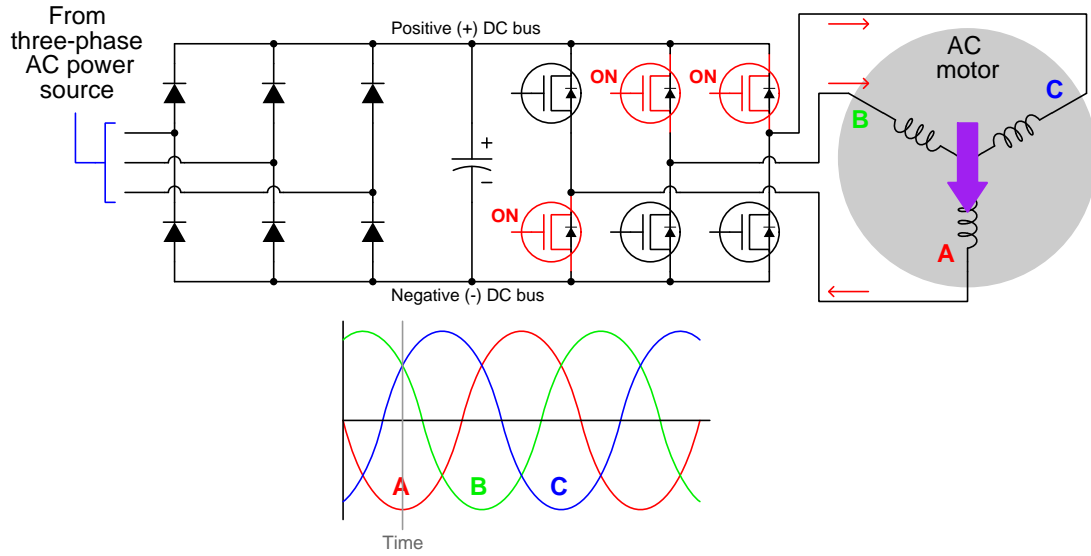



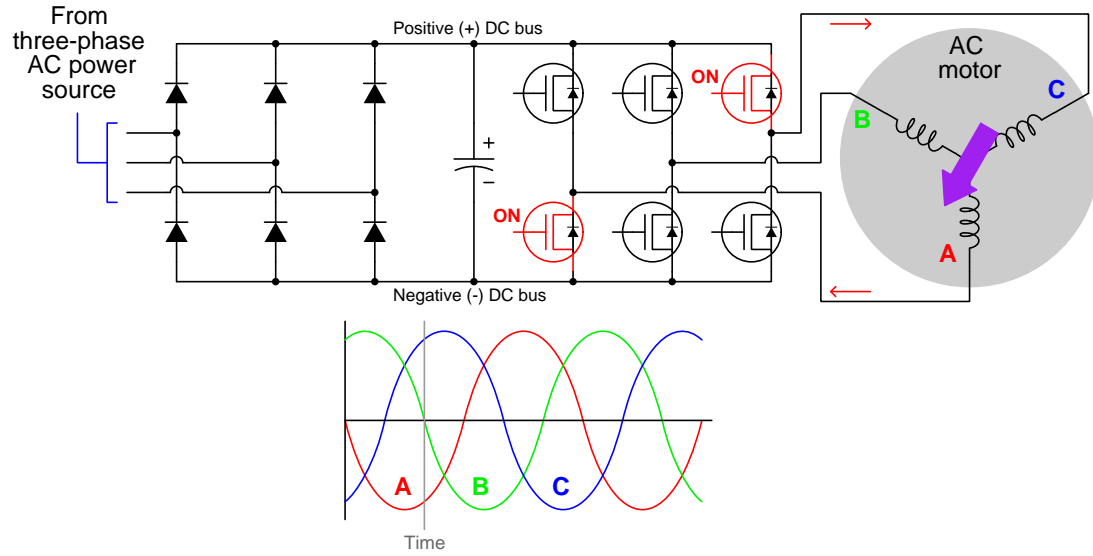

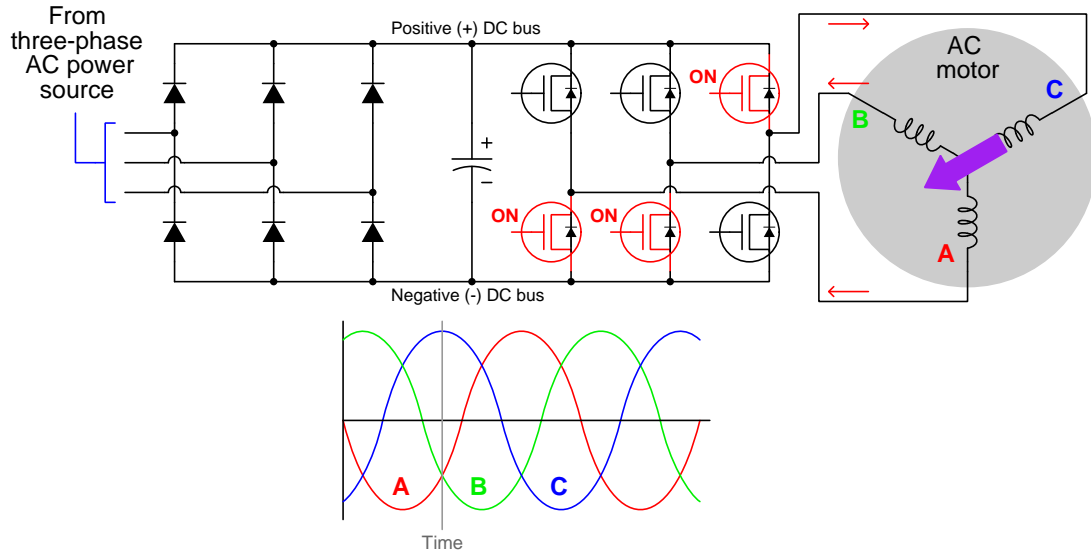

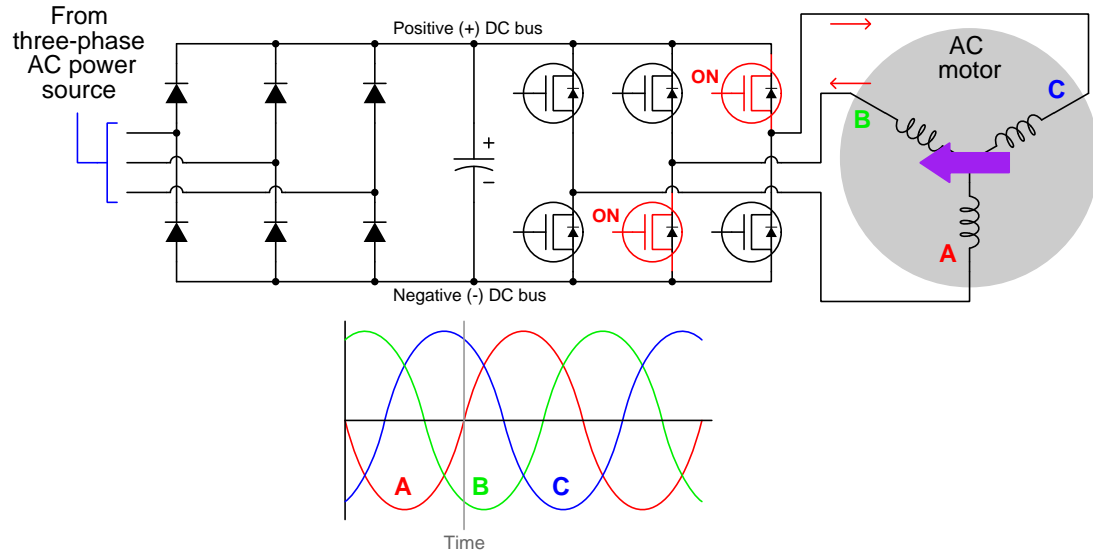

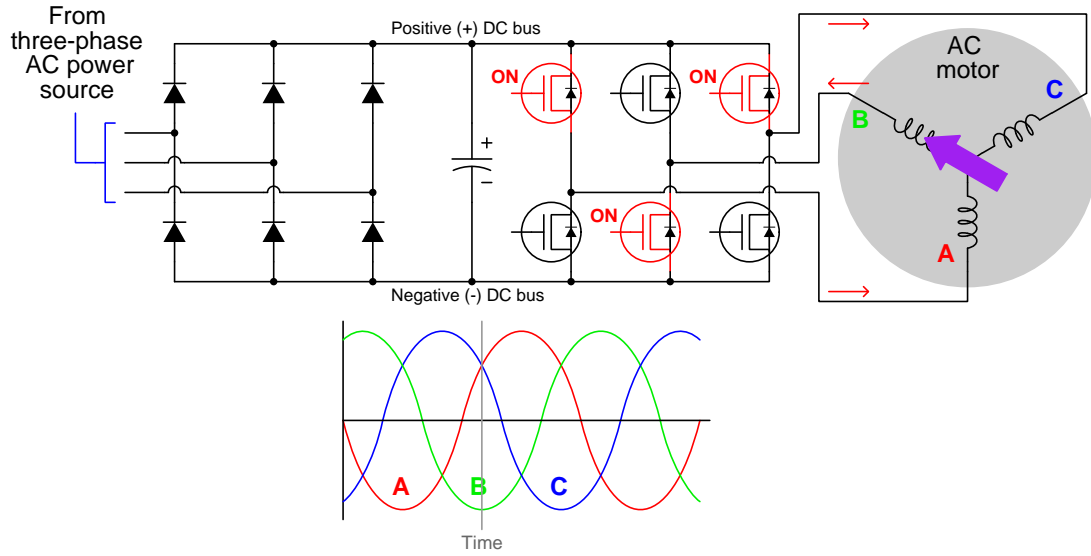

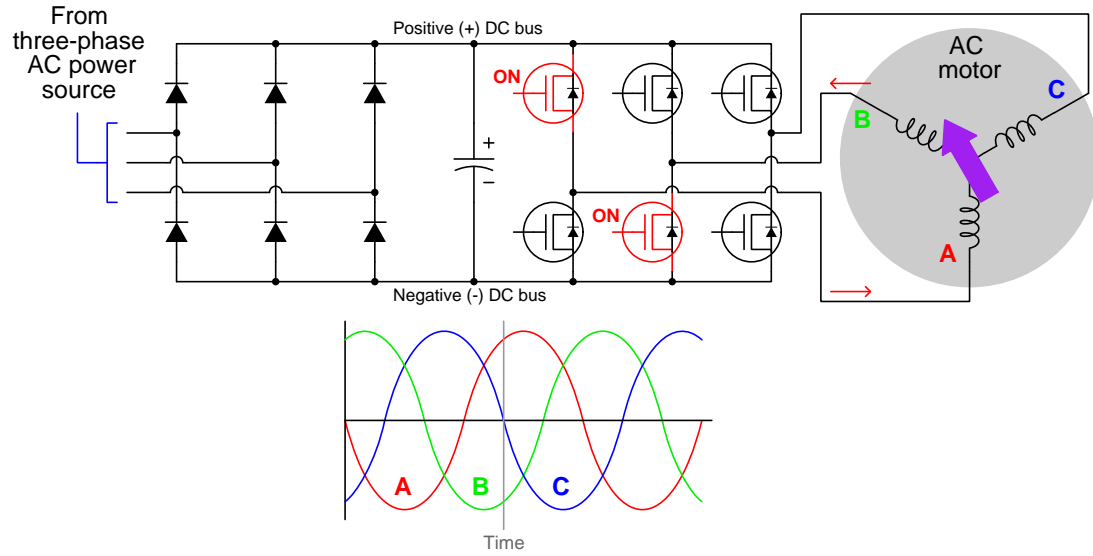

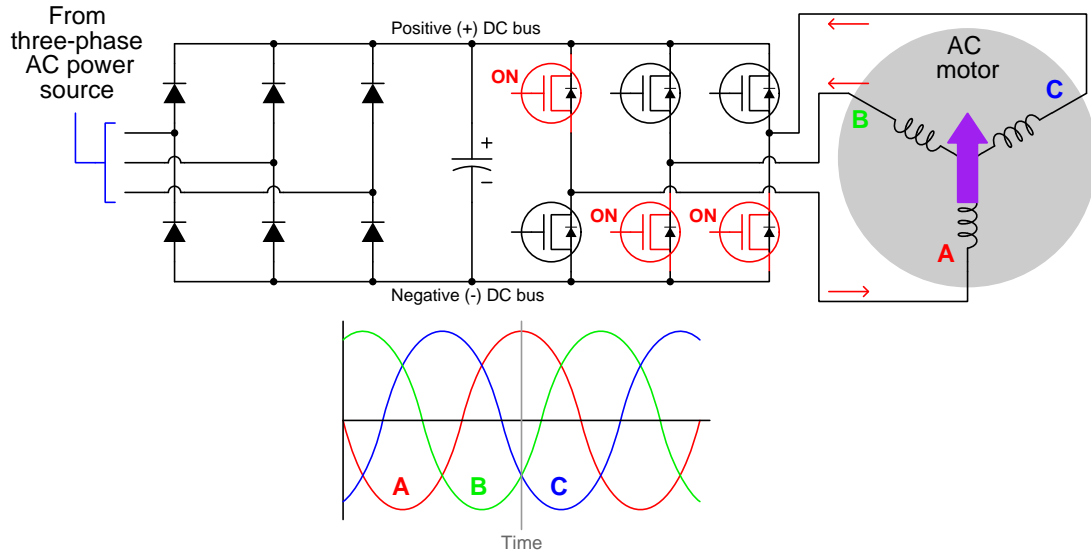

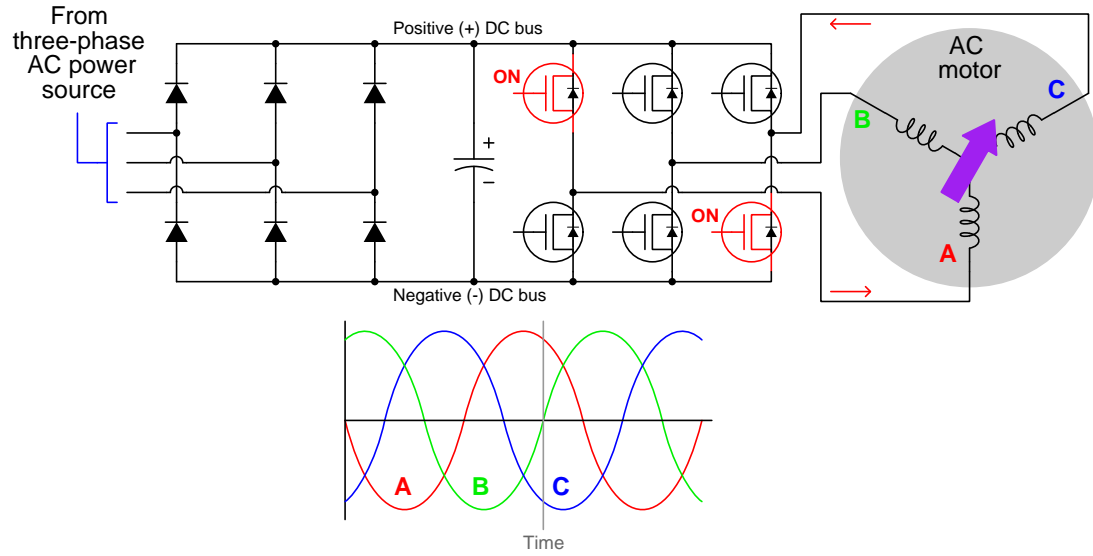

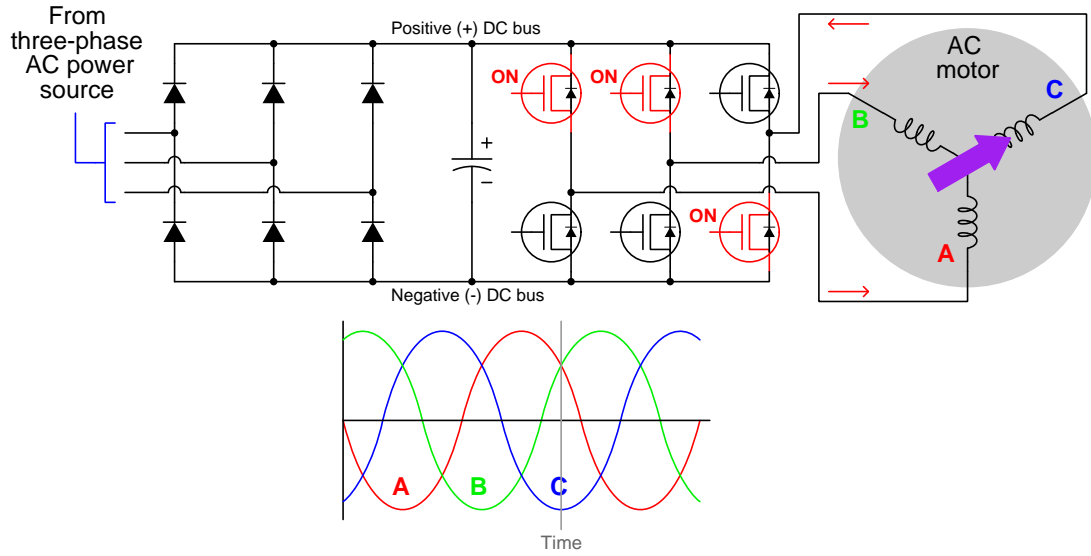



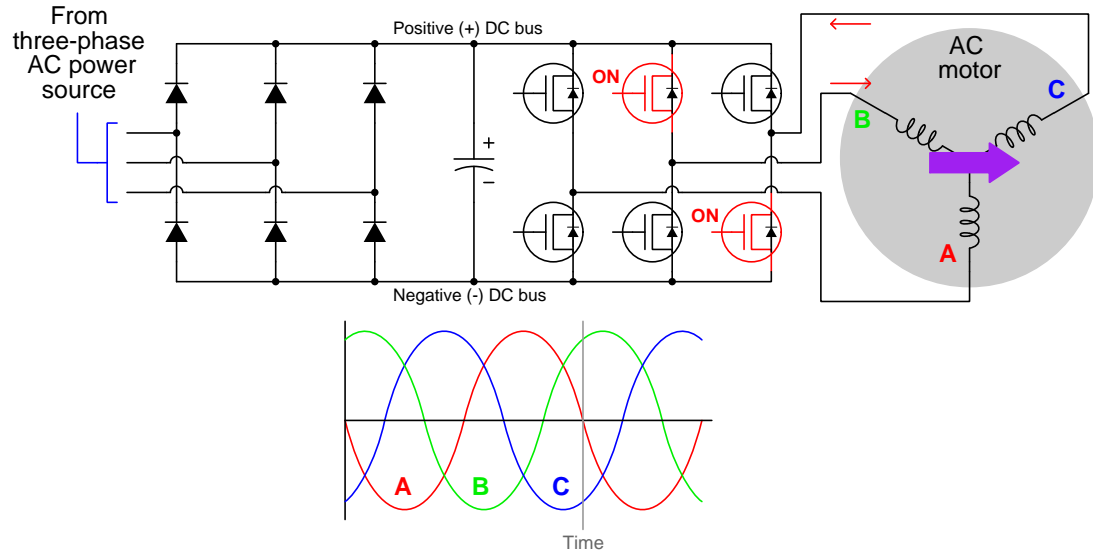

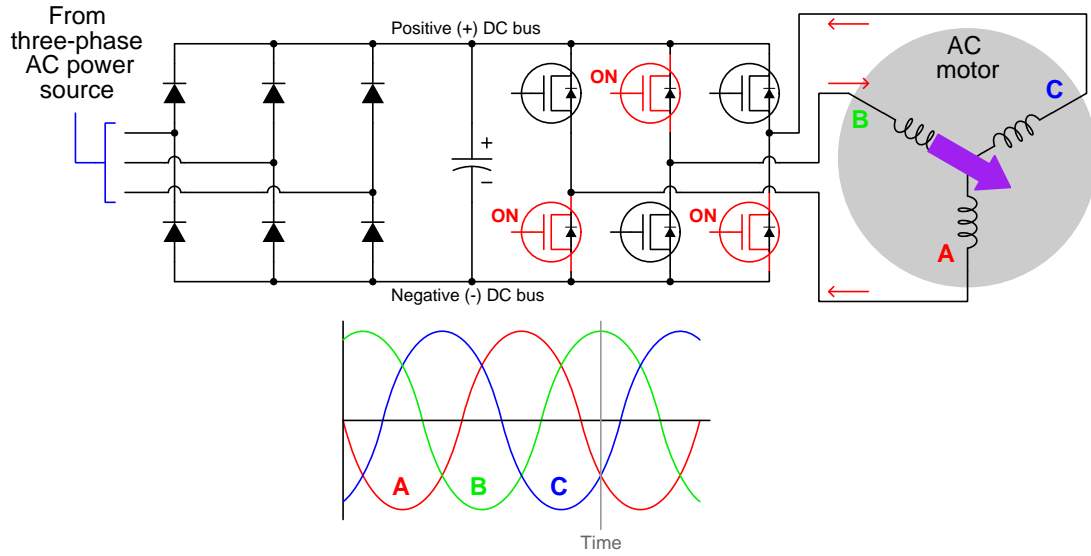

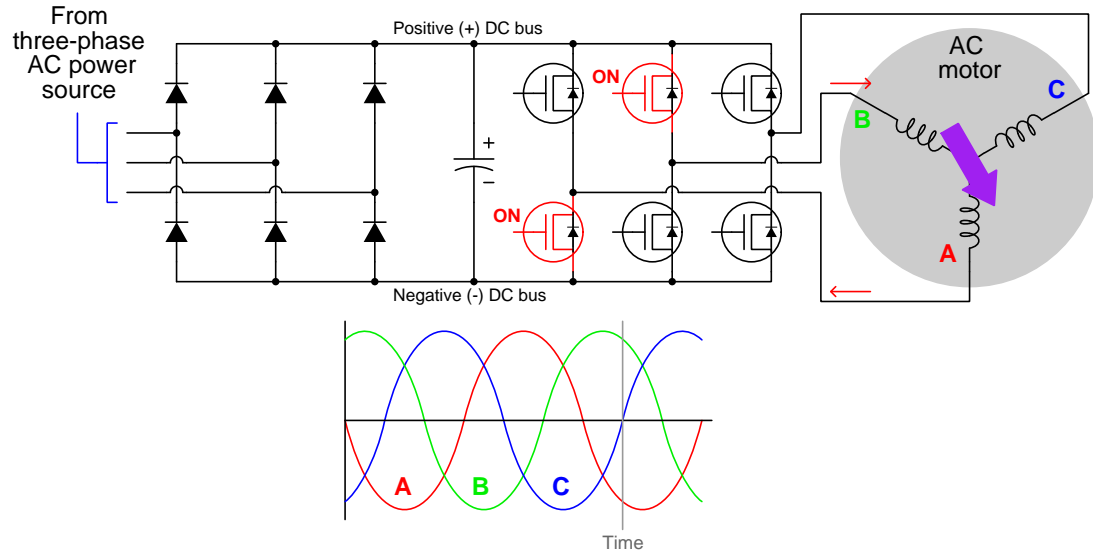

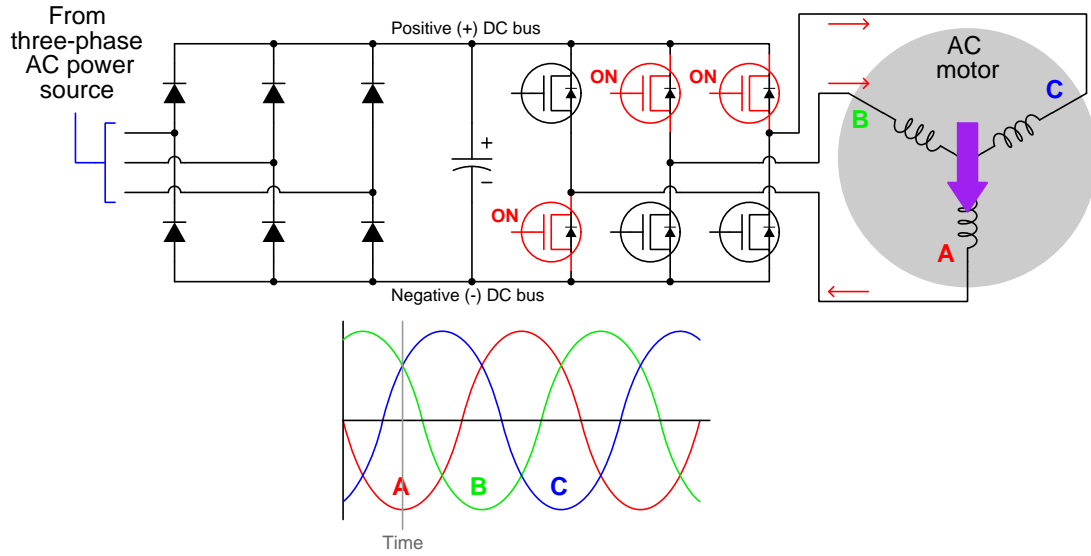

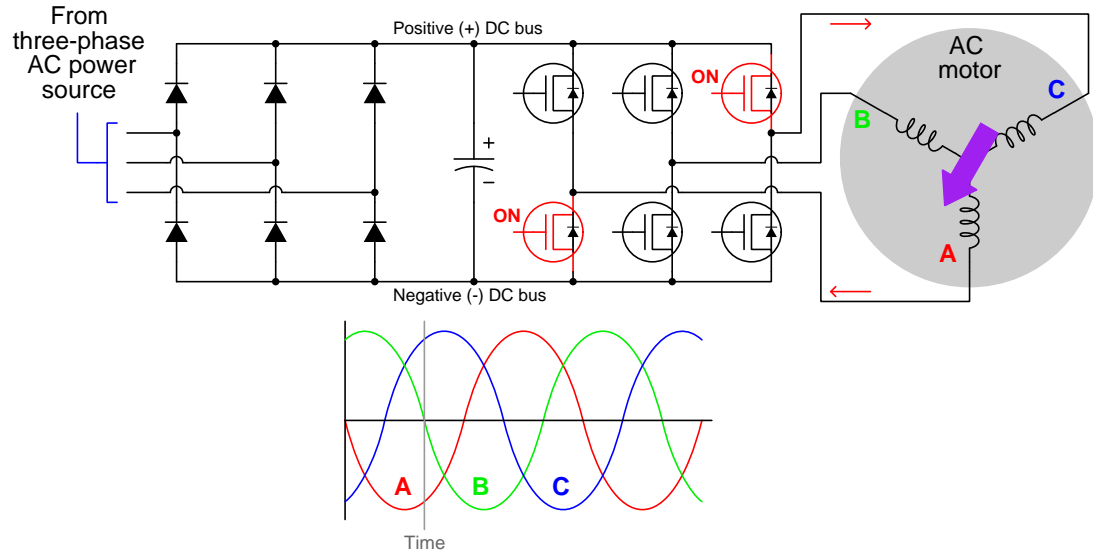

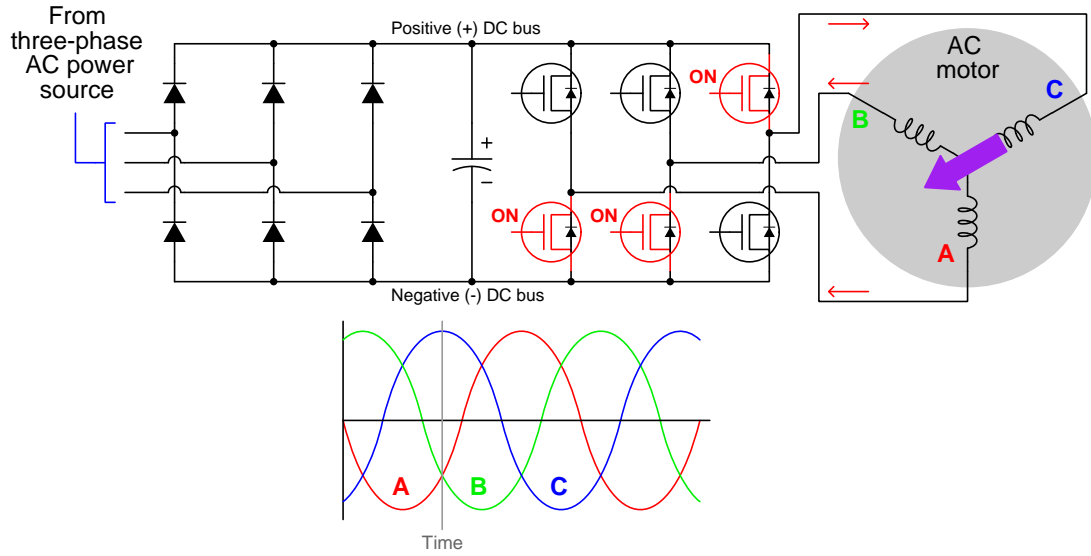

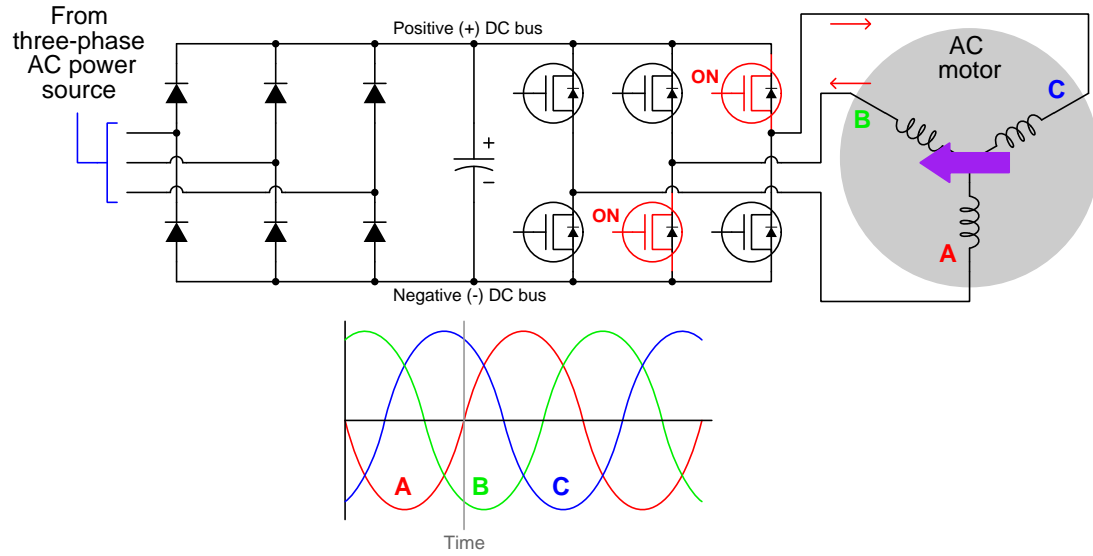

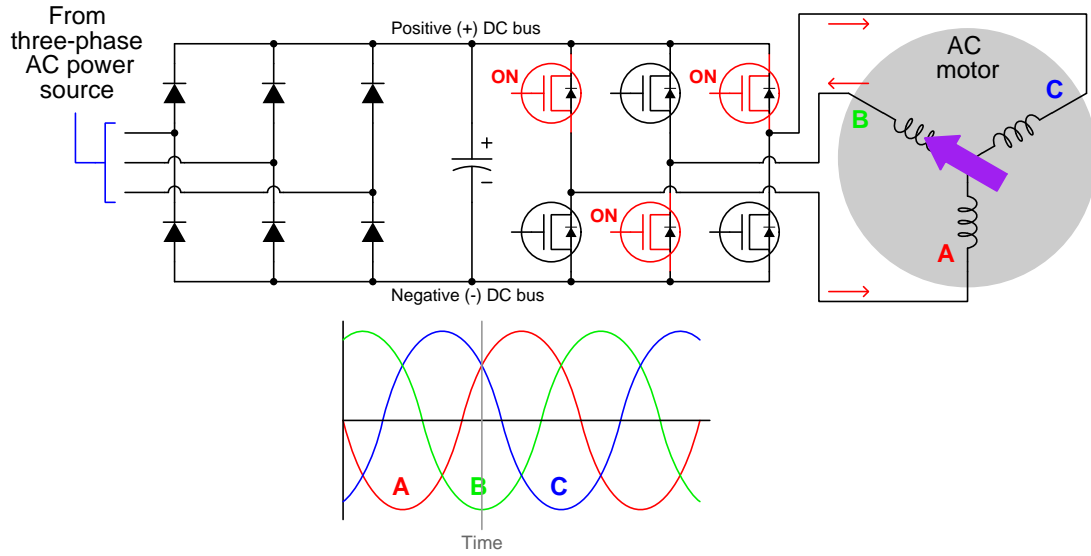



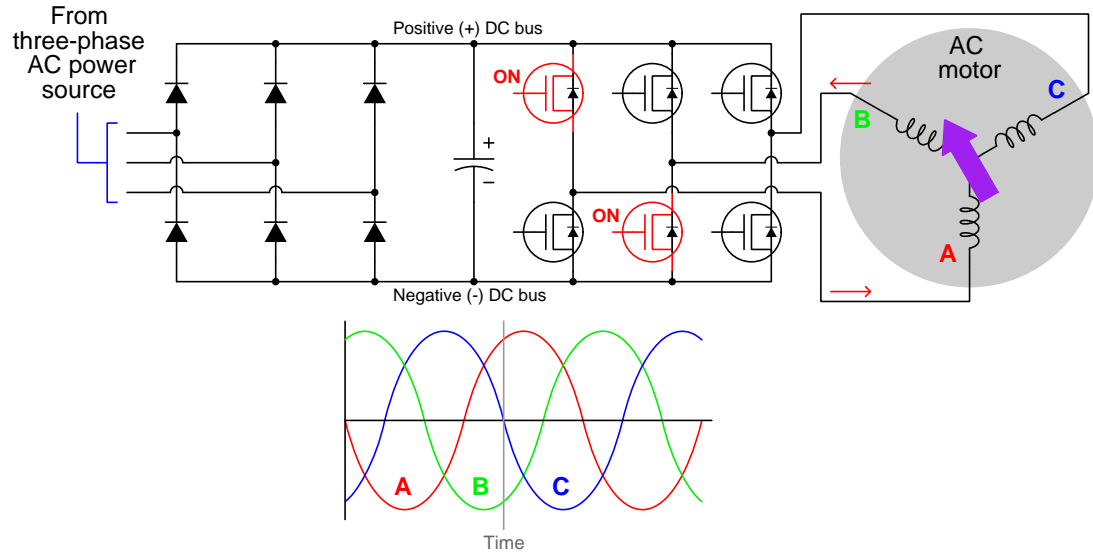

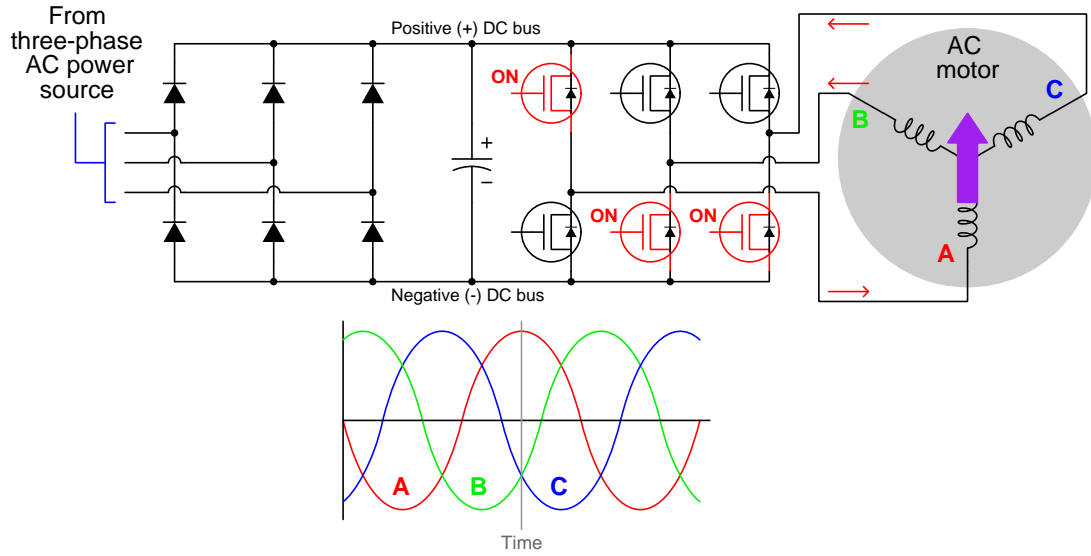

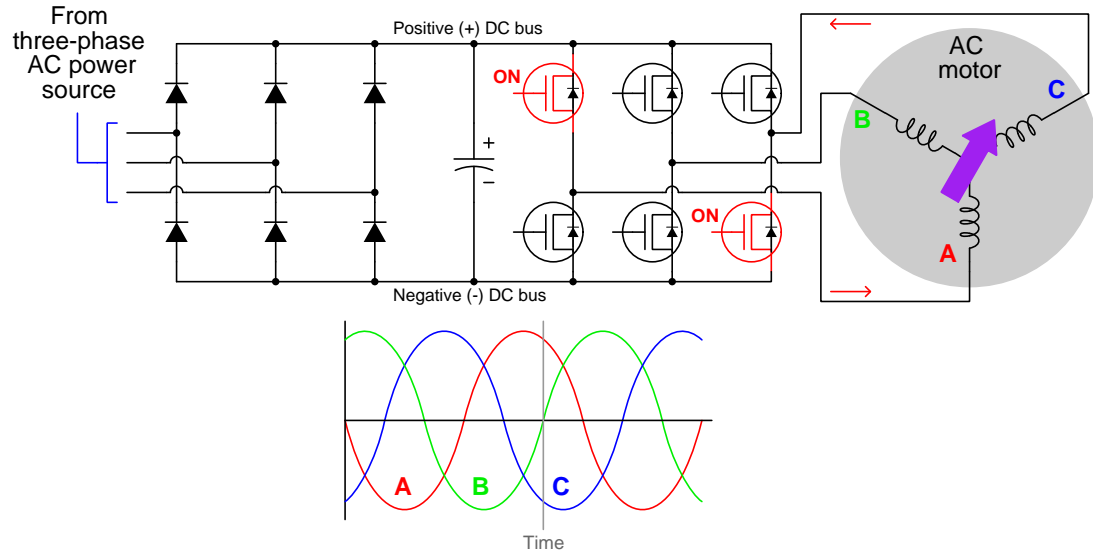

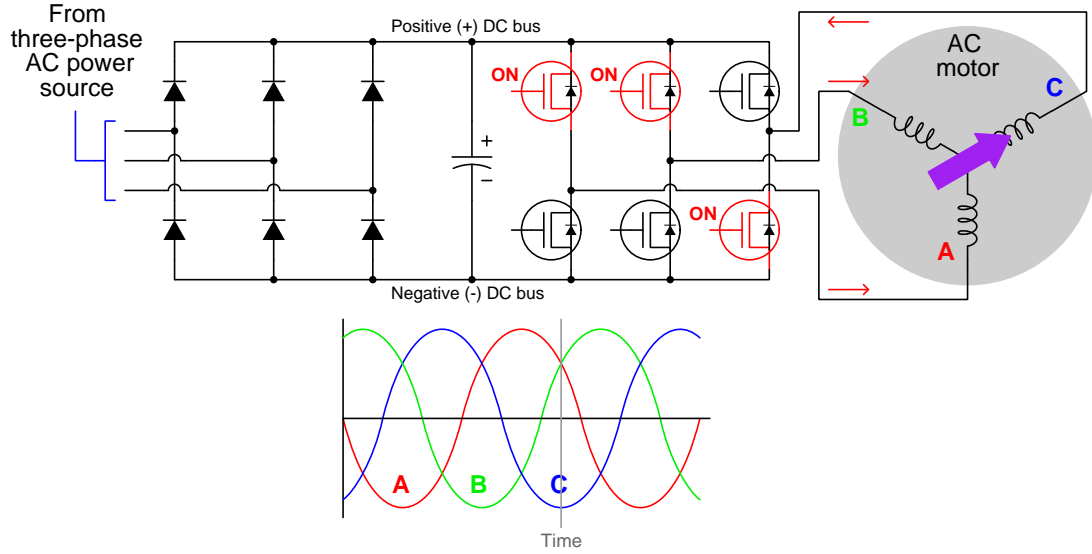

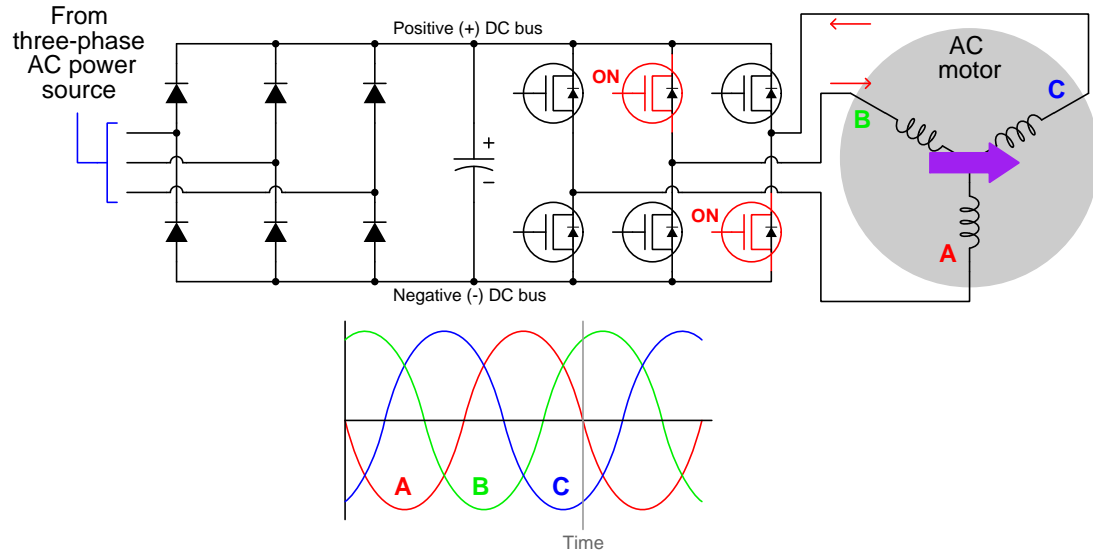

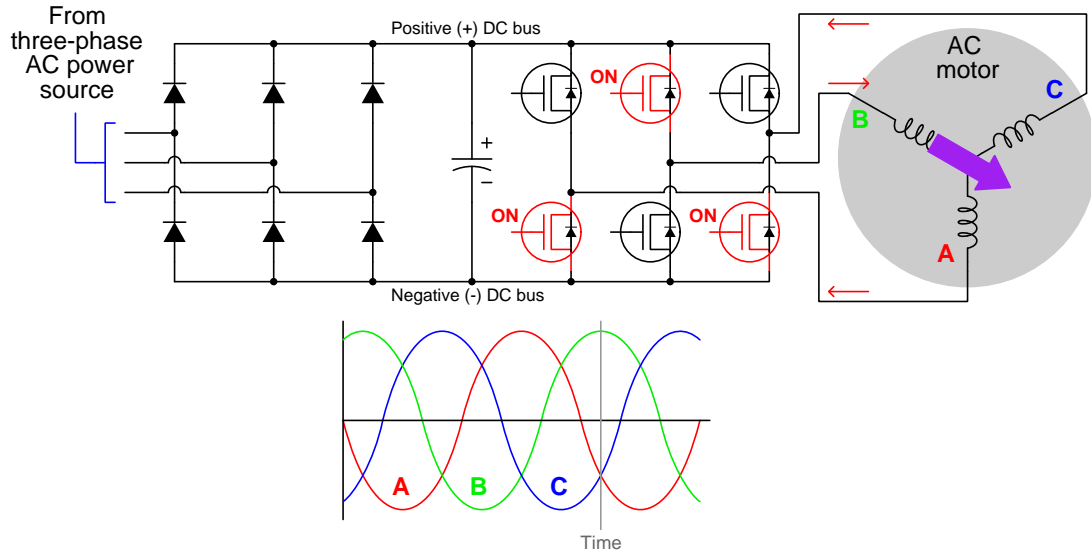

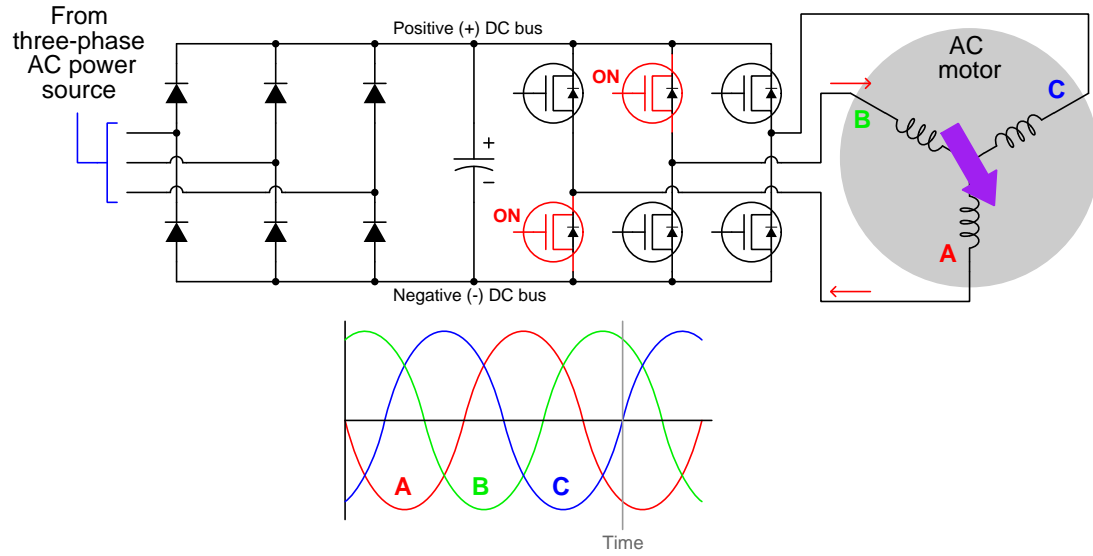

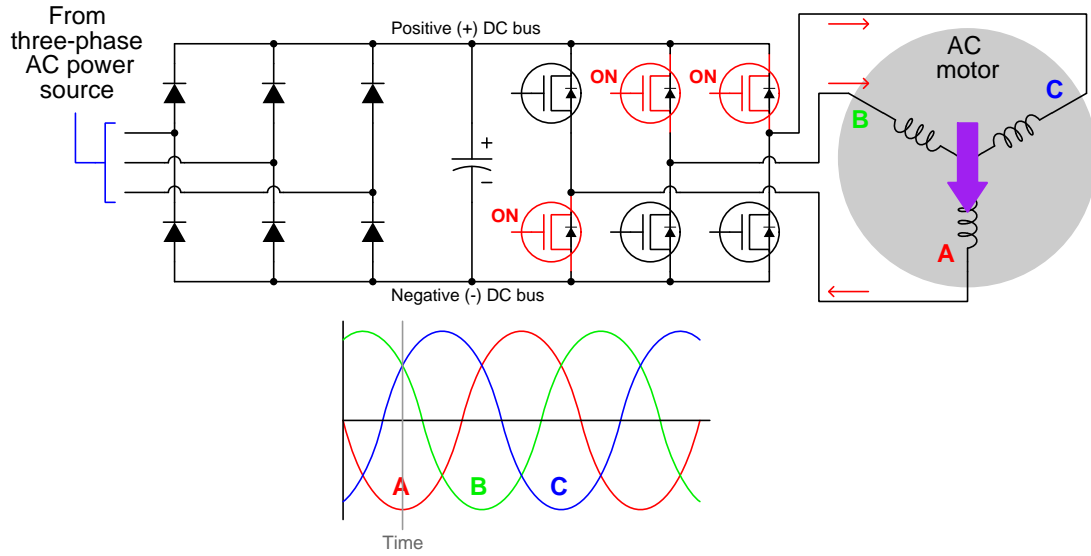





## Chapter 6

# Questions

This learning module, along with all others in the ModEL collection, is designed to be used in an inverted instructional environment where students independently read<sup>1</sup> the tutorials and attempt to answer questions on their own *prior* to the instructor's interaction with them. In place of lecture<sup>2</sup>, the instructor engages with students in Socratic-style dialogue, probing and challenging their understanding of the subject matter through inquiry.

Answers are not provided for questions within this chapter, and this is by design. Solved problems may be found in the Tutorial and Derivation chapters, instead. The goal here is *independence*, and this requires students to be challenged in ways where others cannot think for them. Remember that you always have the tools of *experimentation* and *computer simulation* (e.g. SPICE) to explore concepts!

The following lists contain ideas for Socratic-style questions and challenges. Upon inspection, one will notice a strong theme of *metacognition* within these statements: they are designed to foster a regular habit of examining one's own thoughts as a means toward clearer thinking. As such these sample questions are useful both for instructor-led discussions as well as for self-study.

---

<sup>1</sup>Technical reading is an essential academic skill for any technical practitioner to possess for the simple reason that the most comprehensive, accurate, and useful information to be found for developing technical competence is in textual form. Technical careers in general are characterized by the need for continuous learning to remain current with standards and technology, and therefore any technical practitioner who cannot read well is handicapped in their professional development. An excellent resource for educators on improving students' reading prowess through intentional effort and strategy is the book *Reading For Understanding – How Reading Apprenticeship Improves Disciplinary Learning in Secondary and College Classrooms* by Ruth Schoenbach, Cynthia Greenleaf, and Lynn Murphy.

<sup>2</sup>Lecture is popular as a teaching method because it is easy to implement: any reasonably articulate subject matter expert can talk to students, even with little preparation. However, it is also quite problematic. A good lecture always makes complicated concepts seem easier than they are, which is bad for students because it instills a false sense of confidence in their own understanding; reading and re-articulation requires more cognitive effort and serves to verify comprehension. A culture of teaching-by-lecture fosters a debilitating dependence upon direct personal instruction, whereas the challenges of modern life demand independent and critical thought made possible only by gathering information and perspectives from afar. Information presented in a lecture is ephemeral, easily lost to failures of memory and dictation; text is forever, and may be referenced at any time.

## GENERAL CHALLENGES FOLLOWING TUTORIAL READING

- Summarize as much of the text as you can in one paragraph of your own words. A helpful strategy is to explain ideas as you would for an intelligent child: as simple as you can without compromising too much accuracy.
- Simplify a particular section of the text, for example a paragraph or even a single sentence, so as to capture the same fundamental idea in fewer words.
- Where did the text make the most sense to you? What was it about the text's presentation that made it clear?
- Identify where it might be easy for someone to misunderstand the text, and explain why you think it could be confusing.
- Identify any new concept(s) presented in the text, and explain in your own words.
- Identify any familiar concept(s) such as physical laws or principles applied or referenced in the text.
- Devise a proof of concept experiment demonstrating an important principle, physical law, or technical innovation represented in the text.
- Devise an experiment to disprove a plausible misconception.
- Did the text reveal any misconceptions you might have harbored? If so, describe the misconception(s) and the reason(s) why you now know them to be incorrect.
- Describe any useful problem-solving strategies applied in the text.
- Devise a question of your own to challenge a reader's comprehension of the text.

## GENERAL FOLLOW-UP CHALLENGES FOR ASSIGNED PROBLEMS

- Identify where any fundamental laws or principles apply to the solution of this problem, especially before applying any mathematical techniques.
- Devise a thought experiment to explore the characteristics of the problem scenario, applying known laws and principles to mentally model its behavior.
- Describe in detail your own strategy for solving this problem. How did you identify and organized the given information? Did you sketch any diagrams to help frame the problem?
- Is there more than one way to solve this problem? Which method seems best to you?
- Show the work you did in solving this problem, even if the solution is incomplete or incorrect.
- What would you say was the most challenging part of this problem, and why was it so?
- Was any important information missing from the problem which you had to research or recall?
- Was there any extraneous information presented within this problem? If so, what was it and why did it not matter?
- Examine someone else's solution to identify where they applied fundamental laws or principles.
- Simplify the problem from its given form and show how to solve this simpler version of it. Examples include eliminating certain variables or conditions, altering values to simpler (usually whole) numbers, applying a limiting case (i.e. altering a variable to some extreme or ultimate value).
- For quantitative problems, identify the real-world meaning of all intermediate calculations: their units of measurement, where they fit into the scenario at hand. Annotate any diagrams or illustrations with these calculated values.
- For quantitative problems, try approaching it qualitatively instead, thinking in terms of “increase” and “decrease” rather than definite values.
- For qualitative problems, try approaching it quantitatively instead, proposing simple numerical values for the variables.
- Were there any assumptions you made while solving this problem? Would your solution change if one of those assumptions were altered?
- Identify where it would be easy for someone to go astray in attempting to solve this problem.
- Formulate your own problem based on what you learned solving this one.

## GENERAL FOLLOW-UP CHALLENGES FOR EXPERIMENTS OR PROJECTS

- In what way(s) was this experiment or project easy to complete?
- Identify some of the challenges you faced in completing this experiment or project.

- Show how thorough documentation assisted in the completion of this experiment or project.
- Which fundamental laws or principles are key to this system's function?
- Identify any way(s) in which one might obtain false or otherwise misleading measurements from test equipment in this system.
- What will happen if (component  $X$ ) fails (open/shorted/etc.)?
- What would have to occur to make this system unsafe?

## 6.1 Conceptual reasoning

These questions are designed to stimulate your analytic and synthetic thinking<sup>3</sup>. In a Socratic discussion with your instructor, the goal is for these questions to prompt an extended dialogue where assumptions are revealed, conclusions are tested, and understanding is sharpened. Your instructor may also pose additional questions based on those assigned, in order to further probe and refine your conceptual understanding.

Questions that follow are presented to challenge and probe your understanding of various concepts presented in the tutorial. These questions are intended to serve as a guide for the Socratic dialogue between yourself and the instructor. Your instructor’s task is to ensure you have a sound grasp of these concepts, and the questions contained in this document are merely a means to this end. Your instructor may, at his or her discretion, alter or substitute questions for the benefit of tailoring the discussion to each student’s needs. The only absolute requirement is that each student is challenged and assessed at a level equal to or greater than that represented by the documented questions.

It is far more important that you convey your *reasoning* than it is to simply convey a correct answer. For this reason, you should refrain from researching other information sources to answer questions. What matters here is that *you* are doing the thinking. If the answer is incorrect, your instructor will work with you to correct it through proper reasoning. A correct answer without an adequate explanation of how you derived that answer is unacceptable, as it does not aid the learning or assessment process.

You will note a conspicuous lack of answers given for these conceptual questions. Unlike standard textbooks where answers to every other question are given somewhere toward the back of the book, here in these learning modules students must rely on other means to check their work. The best way by far is to debate the answers with fellow students and also with the instructor during the Socratic dialogue sessions intended to be used with these learning modules. Reasoning through challenging questions with other people is an excellent tool for developing strong reasoning skills.

Another means of checking your conceptual answers, where applicable, is to use circuit simulation software to explore the effects of changes made to circuits. For example, if one of these conceptual questions challenges you to predict the effects of altering some component parameter in a circuit, you may check the validity of your work by simulating that same parameter change within software and seeing if the results agree.

---

<sup>3</sup>*Analytical* thinking involves the “disassembly” of an idea into its constituent parts, analogous to dissection. *Synthetic* thinking involves the “assembly” of a new idea comprised of multiple concepts, analogous to construction. Both activities are high-level cognitive skills, extremely important for effective problem-solving, necessitating frequent challenge and regular practice to fully develop.

### 6.1.1 Reading outline and reflections

*“Reading maketh a full man; conference a ready man; and writing an exact man”* – Francis Bacon

Francis Bacon’s advice is a blueprint for effective education: reading provides the learner with knowledge, writing focuses the learner’s thoughts, and critical dialogue equips the learner to confidently communicate and apply their learning. Independent acquisition and application of knowledge is a powerful skill, well worth the effort to cultivate. To this end, students should read these educational resources closely, journal their own reflections on the reading, and discuss in detail their findings with classmates and instructor(s). You should be able to do all of the following after reading any instructional text:

Briefly SUMMARIZE THE TEXT in the form of a journal entry documenting your learning as you progress through the course of study. Share this summary in dialogue with your classmates and instructor. Journaling is an excellent self-test of thorough reading because you cannot clearly express what you have not read or did not comprehend.

Demonstrate ACTIVE READING STRATEGIES, including verbalizing your impressions as you read, simplifying long passages to convey the same ideas using fewer words, annotating text and illustrations with your own interpretations, working through mathematical examples shown in the text, cross-referencing passages with relevant illustrations and/or other passages, identifying problem-solving strategies applied by the author, etc. Technical reading is a special case of problem-solving, and so these strategies work precisely because they help solve any problem: paying attention to your own thoughts (metacognition), eliminating unnecessary complexities, identifying what makes sense, paying close attention to details, drawing connections between separated facts, and noting the successful strategies of others.

Identify IMPORTANT THEMES, especially GENERAL LAWS and PRINCIPLES, expounded in the text and express them in the simplest of terms as though you were teaching an intelligent child. This emphasizes connections between related topics and develops your ability to communicate complex ideas to anyone.

Form YOUR OWN QUESTIONS based on the reading, and then pose them to your instructor and classmates for their consideration. Anticipate both correct and incorrect answers, the incorrect answer(s) assuming one or more plausible misconceptions. This helps you view the subject from different perspectives to grasp it more fully.

Devise EXPERIMENTS to test claims presented in the reading, or to disprove misconceptions. Predict possible outcomes of these experiments, and evaluate their meanings: what result(s) would confirm, and what would constitute disproof? Running mental simulations and evaluating results is essential to scientific and diagnostic reasoning.

Specifically identify any points you found CONFUSING. The reason for doing this is to help diagnose misconceptions and overcome barriers to learning.

### 6.1.2 Foundational concepts

Correct analysis and diagnosis of electric circuits begins with a proper understanding of some basic concepts. The following is a list of some important concepts referenced in this module's full tutorial. Define each of them in your own words, and be prepared to illustrate each of these concepts with a description of a practical example and/or a live demonstration.

Energy

Conservation of Energy

Rotating magnetic field

Synchronous operation

Induction motor

Slip speed

AC motor speed control

Rectifier

Filter

Inverter

Pulse-Width Modulation (PWM)



Duty cycle

Inductive reactance

V/F ratio

Radio Frequency Interference (RFI)

DC injection braking

Dynamic braking

Regenerative braking

Plugging braking

Motor nameplate parameters

V/Hz profile

Start/stop source

Speed reference source

Harmonic

Triplen harmonic

Cable shield

### 6.1.3 Start-stop-speed-direction control

The most common type of electric motor for industrial applications is the *three-phase AC induction motor*. Its basic principle of operation is rather simple: three AC voltage sources – each one  $120^\circ$  phase-shifted from the other – are connected to energize sets of electromagnet coils inside the motor (called *stator* windings because they are stationary), the result being that each of those coils reaches its full “peak” magnetic force at different times. As these out-of-phase voltages cycle periodically, the stator coils produce a *rotating magnetic field* prompting the motor’s rotor to rotate:

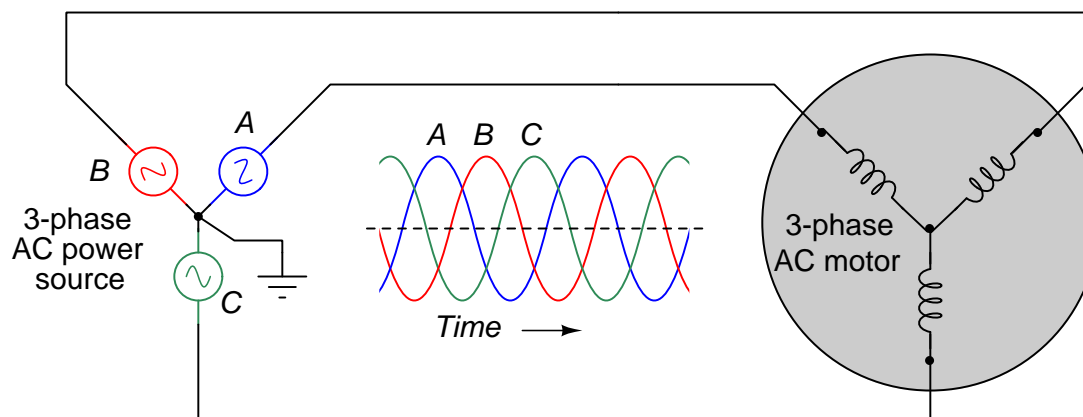

A helpful analogy is that of a string of *chasing lights* where electric lamps blink on and off in sequence to create the appearance of motion. Instead of lamps being energized in sequence, a three-phase AC induction motor’s electromagnet coils energize in sequence to create the “appearance” of a rotating magnetic field.

- Modify the above schematic diagram so that we may start and stop the electric motor at will.
- Based on this understanding of a three-phase AC induction motor, identify what factor(s) determining the motor’s *rotational speed*. Is the speed of a three-phase AC induction motor something we may easily vary? Why or why not?
- Also, identify the factor(s) determining the motor’s *direction of rotation*. Is the direction of a three-phase AC induction motor something we may easily alter? Why or why not?

#### Challenges

- Apply the same questions and reasoning to a set of chasing lights: how to vary the speed of the lamps’ “motion” as well as the direction.
- How do you suppose we generate three-phase AC power? What sort of machine or system might be able to do this?

### 6.1.4 VFD/pump configuration

In the diagram below we see a simple VFD-controlled motor system using a discrete (on/off) signal from a SPST switch to command the VFD to start and stop the motor, while an analog 4-20 mA current signal commands the motor's speed. A network cable allows other data to be written or read by a computer, PLC, or other digital control device. The ability to externally control a VFD makes it very useful as a final control element in an automation system:

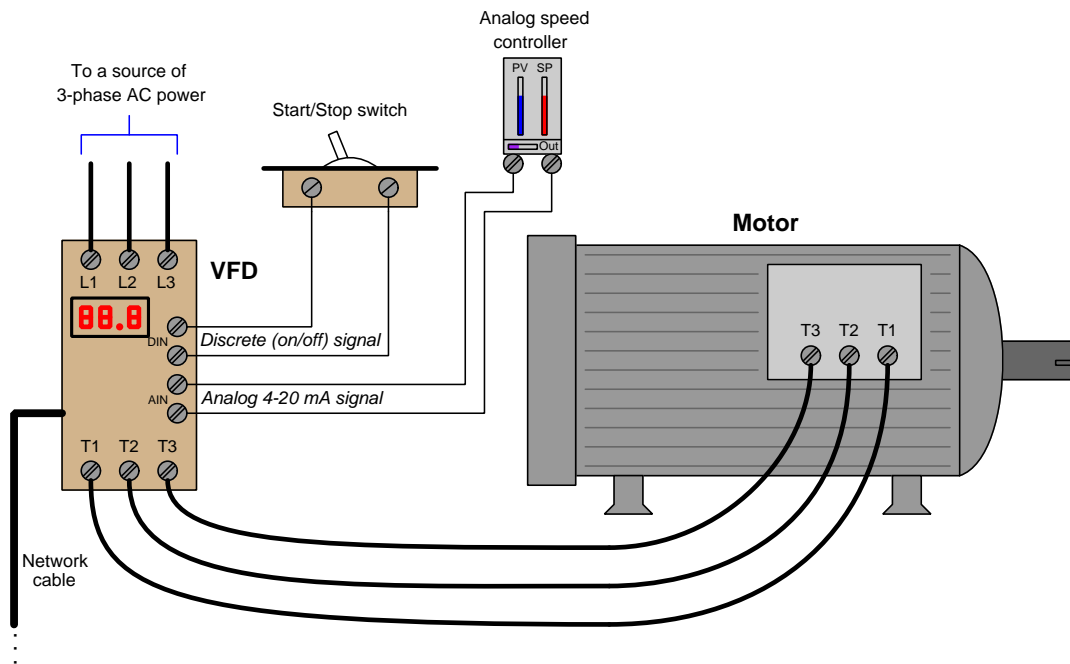

Before any VFD may be used for control purposes, though, it must be *configured* with the correct parameter values necessary to match it to the electric motor, as well as specify its control functionality. This is the task of the on-site technician or engineer tasked with commissioning the motor control system.

Consider a different VFD application controlling a large AC motor turning a pump at a wastewater treatment facility, that motor's nameplate shown below. Suppose we wished to control this pump using a VFD, and needed to configure the VFD for this task. Our intent is to start and stop the motor using a computer digitally communicating with the VFD via a Modbus digital network, with motor speed set by a 4-20 mA analog current signal (with 4 mA being completely stopped and 20 mA being full-speed). Assume we wish to limit the motor's speed to a maximum of 500 RPM:

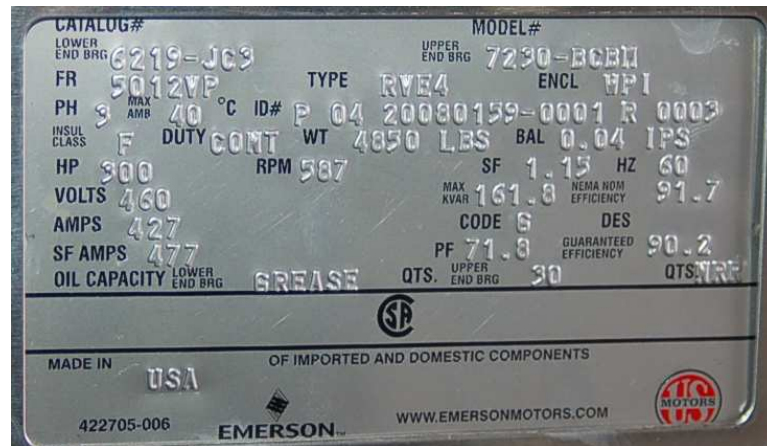

Identify, if possible, reasonable values for each of the following VFD parameters. If there is insufficient information, identify what else you may need to know in order to determine a good parameter value:

- Parameter 01 (Acceleration Time) =
- Parameter 02 (Deceleration Time) =
- Parameter 03 (Volts/Hz Curve) = 0 (*Default*), 1 (*High Torque*), or 2 (*Fans/Pumps*) =
- Parameter 04 (DC Boost) =
- Parameter 05 (Overload Current) =
- Parameter 06 (Line Voltage) =
- Parameter 07 (Base Frequency) =
- Parameter 08 (Base Speed) =
- Parameter 09 (Speed Reference) = 0 (*Keypad*), 1 (*4-20 mA*), 2 (*Modbus*), or 3 (*Fixed*) =
- Parameter 10 (Start Source) = 0 (*Keypad*), 1 (*2-wire switch*), 3 (*3-wire switch*), or 4 (*Modbus*) =
- Parameter 11 (Minimum Output Frequency) =

- Parameter 12 (Maximum Output Frequency) =

Challenges
------------

- Identify some advantages of controlling an electric pump using a VFD, as opposed to having the pump run at a constant speed.
- For an AC induction motor lacking a VFD, what factor(s) determine the motor's shaft speed?

### 6.1.5 Rockwell PowerFlex 4 configuration

Suppose you were asked to configure a Rockwell PowerFlex 4 VFD to a three-phase AC induction motor rated at 208 VAC, 15 Amps, 1740 RPM at full load and 60 Hz. The VFD will be started and stopped from its keypad, and the motor's speed must be controlled by a 5 k $\Omega$  potentiometer over its full range from 0 to 1740 RPM.

Sketch a simple diagram showing the necessary power conductors connected to the VFD and the motor, and identify the important VFD parameter settings for this application.

Challenges
------------

- Identify some of the other start-stop control options for this VFD.
- Identify some of the other speed control options for this VFD.

### 6.1.6 Currents within a VFD circuit

Determine the directions of electric current where you see question marks in the following schematic diagram for a variable-speed AC motor drive, at the moment in time ( $t_1$ ) specified on the oscillograph:

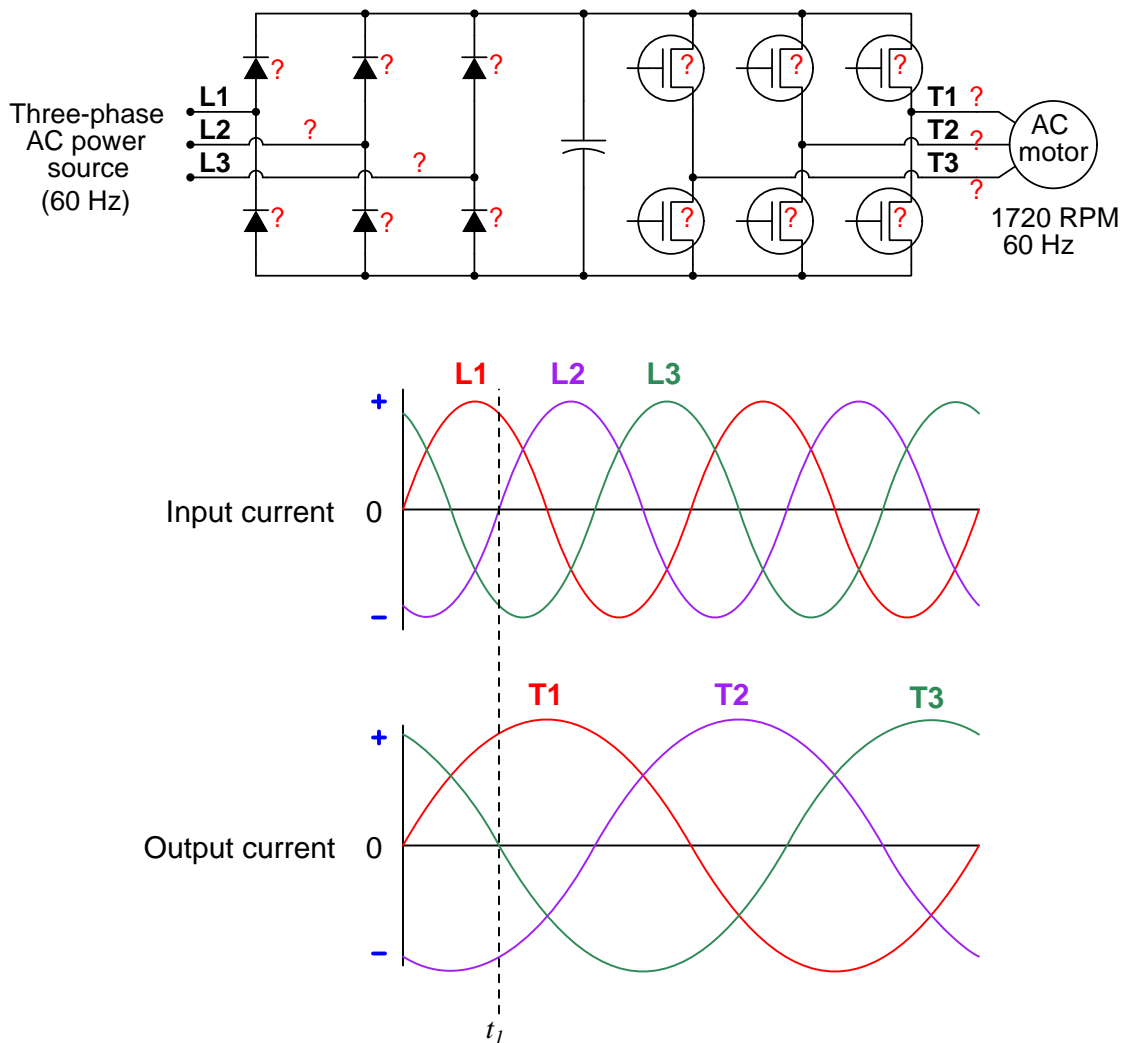

Use conventional flow notation to show current direction (a “positive” current flowing from power source to motor, and a “negative” current flowing from motor to power source). If there is no current going through a labeled wire or component, just write **NO** instead of drawing an arrow on the diagram.

Also, estimate the speed of the three-phase motor based on the waveforms presented assuming the input AC is 60 Hz.

Challenges

- What purpose is served by the capacitor within the VFD?
- What role, if any, does the frequency of the incoming three-phase line power play in determining the frequency of the outgoing three-phase power to the motor?



### 6.1.7 Transistor states

This variable-frequency motor drive (VFD) circuit converts three-phase AC power at 60 Hz into rectified and filtered DC, then switches that DC into three-phase AC of whatever frequency desired. The control circuitry for triggering the MOSFETs is not shown in this diagram, for the sake of simplicity:

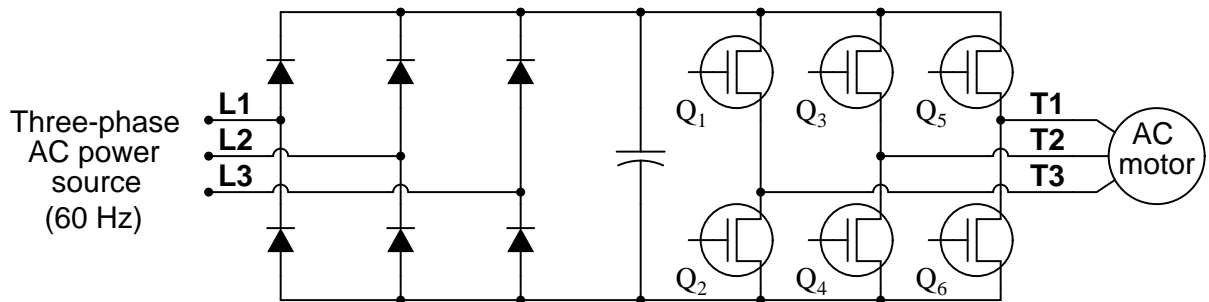

Your task is to determine the states (ON or OFF) of those six transistors during each of the time periods shown in the oscillograph:

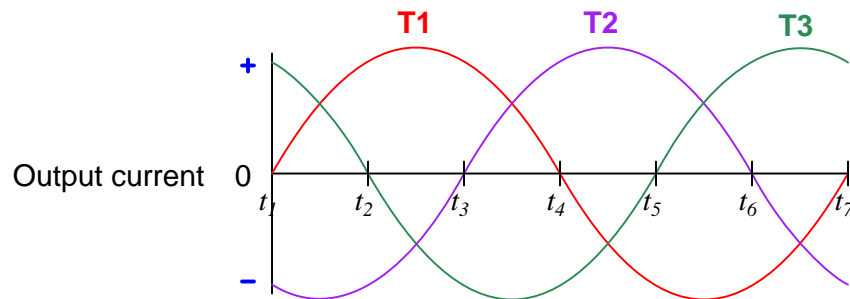

- From time  $t_1$  to  $t_2$ :
- From time  $t_2$  to  $t_3$ :
- From time  $t_3$  to  $t_4$ :
- From time  $t_4$  to  $t_5$ :
- From time  $t_5$  to  $t_6$ :
- From time  $t_6$  to  $t_7$ :

Challenges

- What would be different, if anything, about the switching of these six power transistors to make the motor spin faster?
- What would be different, if anything, about the switching of these six power transistors to make the motor spin in reverse rather than forward?

### 6.1.8 Grinding machine braking

Suppose a large grinding machine used in a production machine shop is powered by an induction motor, which in turn receives its electrical power from a VFD. The time for this machine to coast to a stop after running at full speed is quite long, owing to the mass of the spinning grinding wheel. This “coast” time has a negative effect on production, because the operators must wait until the wheel finally stops before they can take the freshly-ground parts off the machine and replace them with new parts to be ground.

Your supervisor would like to shorten this “stopping” time by using the *dynamic braking* feature of the VFD, which up to this point in time had never been configured for use. Explain where the stored (kinetic) energy of the spinning grinding wheel goes when the VFD dynamically brakes it to a quick stop.

Challenges
------------

- What are some alternative braking techniques to dynamic braking? In each of these techniques, where does the grinding wheel’s kinetic energy go during the braking process?

## 6.2 Quantitative reasoning

These questions are designed to stimulate your computational thinking. In a Socratic discussion with your instructor, the goal is for these questions to reveal your mathematical approach(es) to problem-solving so that good technique and sound reasoning may be reinforced. Your instructor may also pose additional questions based on those assigned, in order to observe your problem-solving firsthand.

Mental arithmetic and estimations are strongly encouraged for all calculations, because without these abilities you will be unable to readily detect errors caused by calculator misuse (e.g. keystroke errors).

You will note a conspicuous lack of answers given for these quantitative questions. Unlike standard textbooks where answers to every other question are given somewhere toward the back of the book, here in these learning modules students must rely on other means to check their work. My advice is to use circuit simulation software such as SPICE to check the correctness of quantitative answers. Refer to those learning modules within this collection focusing on SPICE to see worked examples which you may use directly as practice problems for your own study, and/or as templates you may modify to run your own analyses and generate your own practice problems.

Completely worked example problems found in the Tutorial may also serve as “test cases<sup>4</sup>” for gaining proficiency in the use of circuit simulation software, and then once that proficiency is gained you will never need to rely<sup>5</sup> on an answer key!

---

<sup>4</sup>In other words, set up the circuit simulation software to analyze the same circuit examples found in the Tutorial. If the simulated results match the answers shown in the Tutorial, it confirms the simulation has properly run. If the simulated results disagree with the Tutorial’s answers, something has been set up incorrectly in the simulation software. Using every Tutorial as practice in this way will quickly develop proficiency in the use of circuit simulation software.

<sup>5</sup>This approach is perfectly in keeping with the instructional philosophy of these learning modules: *teaching students to be self-sufficient thinkers*. Answer keys can be useful, but it is even more useful to your long-term success to have a set of tools on hand for checking your own work, because once you have left school and are on your own, there will no longer be “answer keys” available for the problems you will have to solve.

### 6.2.1 Miscellaneous physical constants

Note: constants shown in **bold** type are *exact*, not approximations. Values inside of parentheses show one standard deviation ( $\sigma$ ) of uncertainty in the final digits: for example, the magnetic permeability of free space value given as  $1.25663706212(19) \times 10^{-6}$  H/m represents a center value (i.e. the location parameter) of  $1.25663706212 \times 10^{-6}$  Henrys per meter with one standard deviation of uncertainty equal to  $0.0000000000019 \times 10^{-6}$  Henrys per meter.

Avogadro's number ( $N_A$ ) = **6.02214076**  $\times 10^{23}$  **per mole** (mol<sup>-1</sup>)

Boltzmann's constant ( $k$ ) = **1.380649**  $\times 10^{-23}$  **Joules per Kelvin** (J/K)

Electronic charge ( $e$ ) = **1.602176634**  $\times 10^{-19}$  **Coulomb** (C)

Faraday constant ( $F$ ) = **96,485.33212...**  $\times 10^4$  **Coulombs per mole** (C/mol)

Magnetic permeability of free space ( $\mu_0$ ) = **1.25663706212(19)**  $\times 10^{-6}$  Henrys per meter (H/m)

Electric permittivity of free space ( $\epsilon_0$ ) = **8.8541878128(13)**  $\times 10^{-12}$  Farads per meter (F/m)

Characteristic impedance of free space ( $Z_0$ ) = **376.730313668(57)** Ohms ( $\Omega$ )

Gravitational constant ( $G$ ) = **6.67430(15)**  $\times 10^{-11}$  cubic meters per kilogram-seconds squared (m<sup>3</sup>/kg-s<sup>2</sup>)

Molar gas constant ( $R$ ) = **8.314462618...** **Joules per mole-Kelvin** (J/mol-K) = 0.08205746(14) liters-atmospheres per mole-Kelvin

Planck constant ( $h$ ) = **6.62607015**  $\times 10^{-34}$  **joule-seconds** (J-s)

Stefan-Boltzmann constant ( $\sigma$ ) = **5.670374419...**  $\times 10^{-8}$  **Watts per square meter-Kelvin<sup>4</sup>** (W/m<sup>2</sup>·K<sup>4</sup>)

Speed of light in a vacuum ( $c$ ) = **299,792,458 meters per second** (m/s) = 186282.4 miles per second (mi/s)

Note: All constants taken from NIST data "Fundamental Physical Constants – Complete Listing", from <http://physics.nist.gov/constants>, National Institute of Standards and Technology (NIST), 2018 CODATA Adjustment.

### 6.2.2 Introduction to spreadsheets

A powerful computational tool you are encouraged to use in your work is a *spreadsheet*. Available on most personal computers (e.g. Microsoft Excel), *spreadsheet* software performs numerical calculations based on number values and formulae entered into cells of a grid. This grid is typically arranged as lettered columns and numbered rows, with each cell of the grid identified by its column/row coordinates (e.g. cell B3, cell A8). Each cell may contain a string of text, a number value, or a mathematical formula. The spreadsheet automatically updates the results of all mathematical formulae whenever the entered number values are changed. This means it is possible to set up a spreadsheet to perform a series of calculations on entered data, and those calculations will be re-done by the computer any time the data points are edited in any way.

For example, the following spreadsheet calculates average speed based on entered values of distance traveled and time elapsed:

	A	B	C	D
1	Distance traveled	46.9	Kilometers	
2	Time elapsed	1.18	Hours	
3	Average speed	= B1 / B2	km/h	
4				
5				

Text labels contained in cells A1 through A3 and cells C1 through C3 exist solely for readability and are not involved in any calculations. Cell B1 contains a sample distance value while cell B2 contains a sample time value. The formula for computing speed is contained in cell B3. Note how this formula begins with an “equals” symbol (=), references the values for distance and speed by lettered column and numbered row coordinates (B1 and B2), and uses a forward slash symbol for division (/). The coordinates B1 and B2 function as *variables*<sup>6</sup> would in an algebraic formula.

When this spreadsheet is executed, the numerical value 39.74576 will appear in cell B3 rather than the formula = B1 / B2, because 39.74576 is the computed speed value given 46.9 kilometers traveled over a period of 1.18 hours. If a different numerical value for distance is entered into cell B1 or a different value for time is entered into cell B2, cell B3’s value will automatically update. All you need to do is set up the given values and any formulae into the spreadsheet, and the computer will do all the calculations for you.

Cell B3 may be referenced by other formulae in the spreadsheet if desired, since it is a variable just like the given values contained in B1 and B2. This means it is possible to set up an entire chain of calculations, one dependent on the result of another, in order to arrive at a final value. The arrangement of the given data and formulae need not follow any pattern on the grid, which means you may place them anywhere.

---

<sup>6</sup>Spreadsheets may also provide means to attach text labels to cells for use as variable names (Microsoft Excel simply calls these labels “names”), but for simple spreadsheets such as those shown here it’s usually easier just to use the standard coordinate naming for each cell.

Common<sup>7</sup> arithmetic operations available for your use in a spreadsheet include the following:

- Addition (+)
- Subtraction (-)
- Multiplication (\*)
- Division (/)
- Powers (^)
- Square roots (sqrt())
- Logarithms (ln() , log10())

Parentheses may be used to ensure<sup>8</sup> proper order of operations within a complex formula. Consider this example of a spreadsheet implementing the *quadratic formula*, used to solve for roots of a polynomial expression in the form of  $ax^2 + bx + c$ :

$$x = \frac{-b \pm \sqrt{b^2 - 4ac}}{2a}$$

	A	B
1	x_1	= (-B4 + sqrt((B4^2) - (4*B3*B5))) / (2*B3)
2	x_2	= (-B4 - sqrt((B4^2) - (4*B3*B5))) / (2*B3)
3	a =	9
4	b =	5
5	c =	-2

This example is configured to compute roots<sup>9</sup> of the polynomial  $9x^2 + 5x - 2$  because the values of 9, 5, and  $-2$  have been inserted into cells B3, B4, and B5, respectively. Once this spreadsheet has been built, though, it may be used to calculate the roots of *any* second-degree polynomial expression simply by entering the new  $a$ ,  $b$ , and  $c$  coefficients into cells B3 through B5. The numerical values appearing in cells B1 and B2 will be automatically updated by the computer immediately following any changes made to the coefficients.

<sup>7</sup>Modern spreadsheet software offers a bewildering array of mathematical functions you may use in your computations. I recommend you consult the documentation for your particular spreadsheet for information on operations other than those listed here.

<sup>8</sup>Spreadsheet programs, like text-based programming languages, are designed to follow standard order of operations by default. However, my personal preference is to use parentheses even where strictly unnecessary just to make it clear to any other person viewing the formula what the intended order of operations is.

<sup>9</sup>Reviewing some algebra here, a *root* is a value for  $x$  that yields an overall value of zero for the polynomial. For this polynomial ( $9x^2 + 5x - 2$ ) the two roots happen to be  $x = 0.269381$  and  $x = -0.82494$ , with these values displayed in cells B1 and B2, respectively upon execution of the spreadsheet.

Alternatively, one could break up the long quadratic formula into smaller pieces like this:

$$y = \sqrt{b^2 - 4ac} \quad z = 2a$$

$$x = \frac{-b \pm y}{z}$$

	<b>A</b>	<b>B</b>	<b>C</b>
<b>1</b>	x_1	= (-B4 + C1) / C2	= sqrt( (B4^2) - (4*B3*B5) )
<b>2</b>	x_2	= (-B4 - C1) / C2	= 2*B3
<b>3</b>	a =	9	
<b>4</b>	b =	5	
<b>5</b>	c =	-2	

Note how the square-root term ( $y$ ) is calculated in cell C1, and the denominator term ( $z$ ) in cell C2. This makes the two final formulae (in cells B1 and B2) simpler to interpret. The positioning of all these cells on the grid is completely arbitrary<sup>10</sup> – all that matters is that they properly reference each other in the formulae.

Spreadsheets are particularly useful for situations where the same set of calculations representing a circuit or other system must be repeated for different initial conditions. The power of a spreadsheet is that it automates what would otherwise be a tedious set of calculations. One specific application of this is to simulate the effects of various components within a circuit failing with abnormal values (e.g. a shorted resistor simulated by making its value nearly zero; an open resistor simulated by making its value extremely large). Another application is analyzing the behavior of a circuit design given new components that are out of specification, and/or aging components experiencing drift over time.

<sup>10</sup>My personal preference is to locate all the “given” data in the upper-left cells of the spreadsheet grid (each data point flanked by a sensible name in the cell to the left and units of measurement in the cell to the right as illustrated in the first distance/time spreadsheet example), sometimes coloring them in order to clearly distinguish which cells contain entered data versus which cells contain computed results from formulae. I like to place all formulae in cells below the given data, and try to arrange them in logical order so that anyone examining my spreadsheet will be able to figure out *how* I constructed a solution. This is a general principle I believe all computer programmers should follow: *document and arrange your code to make it easy for other people to learn from it.*

### 6.2.3 Three-phase simulation program

The following computer program written in the C language simulates AC waveforms in a three-phase system:

```
#include <stdio.h>
#include <math.h>

float sinecalc(float);

int main (void)
{
    float angle;
    int n;

    printf("Angle , Phase A , Phase B , Phase C");

    for (angle = 0 ; angle <= 720 ; angle = angle + 10.0)
    {
        printf("\n%f", angle);

        for (n = 0 ; n <= 2 ; ++n)
        {
            printf(" , %f", sinecalc(angle + (n * 120)));
        }
    }

    return 0;
}

float sinecalc (float input)
{
    return sin(input * M_PI / 180);
}
```

This program outputs text in a comma-separated-variable (CSV) format suitable for plotting with spreadsheet or other math visualization software, a plot shown on the following page.



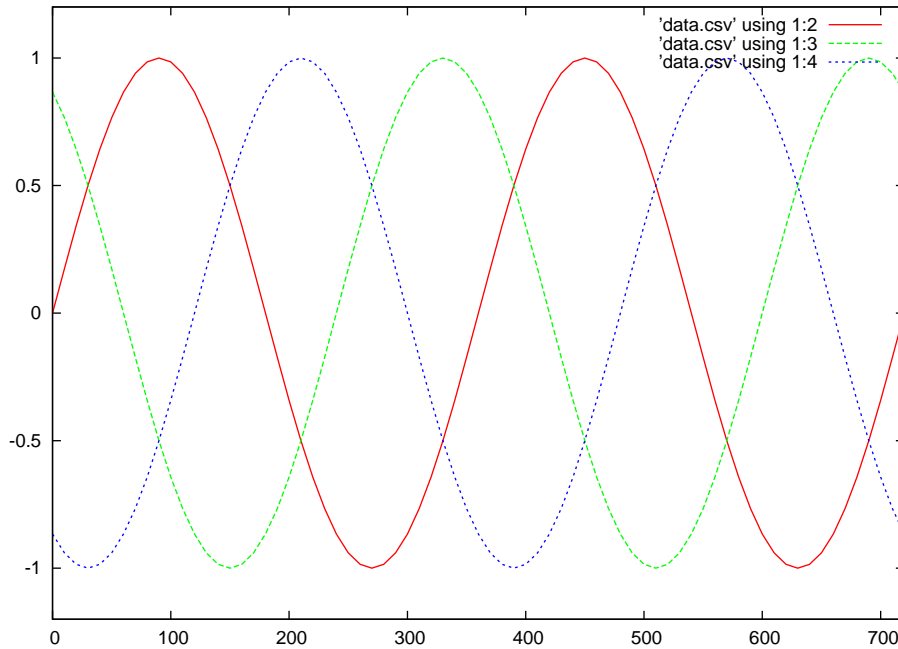

Answer the following questions about the program and its corresponding plotted output:

- What purpose is served by the `sinecalc()` function?
- Which waveform in the plot represents the “A” phase, the “B” phase, and the “C” phase?
- How are the three different phase angles of these waveforms implemented in the code?
- Are both `for()` loops strictly necessary in this program?
- What would happen if the `10.0` constant value were set to `30.0` instead?
- How could the code be modified to plot waveforms with RMS values of 277 Volts each?

#### Challenges

- Do these plotted waveforms have a specific frequency? Why or why not?
- If we were to use this code as part of a VFD control program running in a microcontroller IC, how might its output interface with the real world of the electric motor being controlled?

### 6.2.4 Line reactor harmonic impedance

A common “accessory” device for a variable-frequency drive (VFD) is a *line reactor*, which is nothing more than a large inductor connected in series with each of the motor drive’s power line conductors. The purpose of a line reactor is to act as a low-pass filter, allowing 60 Hz power to the VFD but blocking harmonic frequencies generated by the VFD from “corrupting” the AC power supply system.

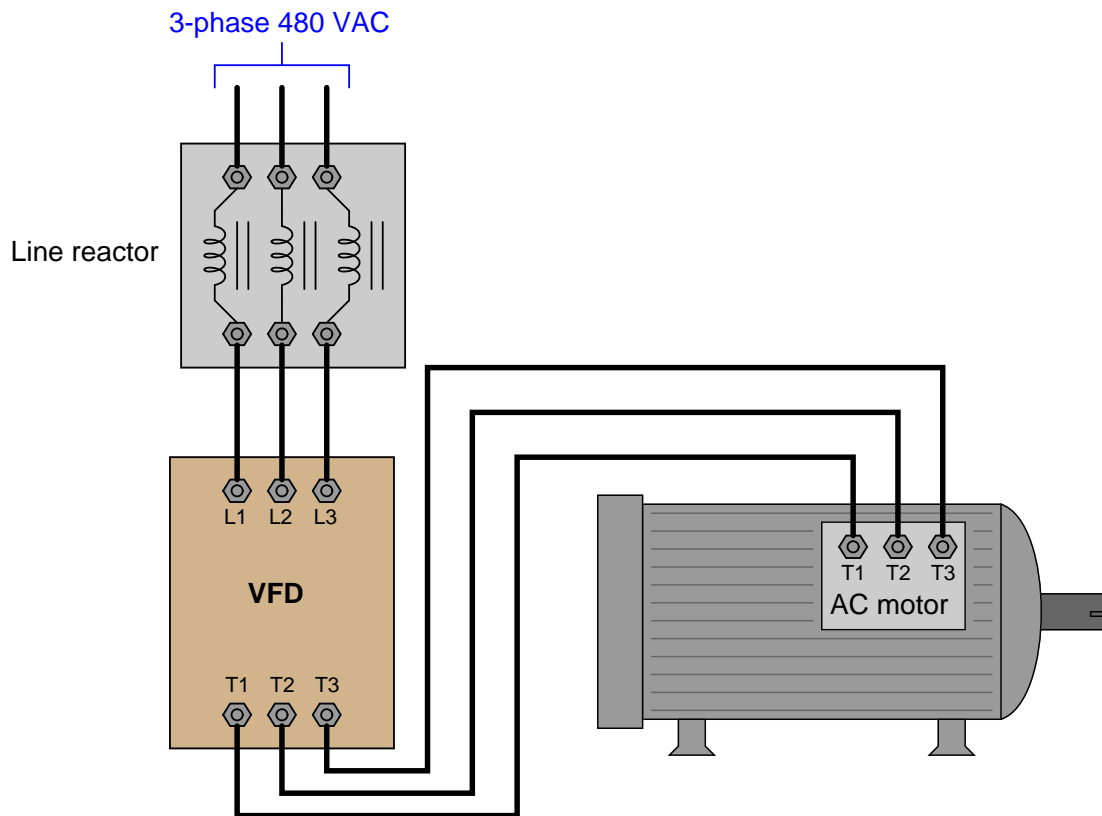

Suppose each winding of a line reactor for a 10 horsepower VFD has  $0.119 \Omega$  of resistance and 1.5 mH of inductance. Calculate the amount of *impedance* offered by each winding to the following harmonics:

- 1st harmonic:
- 3rd harmonic:
- 5th harmonic:
- 7th harmonic:
- 9th harmonic:

Challenges
------------

- Normally a low-pass inductive filter requires a resistor as well as an inductor to make the filtering complete. Where is the resistor here?

### 6.2.5 Line reactor resonance

An AC electric power system has a bank of capacitors connected to correct for low power factor. One day a new VFD is installed to provide variable-speed control for an existing AC motor. The VFD has its own line reactors connected on the input side to help filter harmonics from the rest of the AC power system. The problem is, the line reactors and the power factor correction capacitors now form a *resonant circuit* that may produce high currents and/or voltages at a certain frequency:

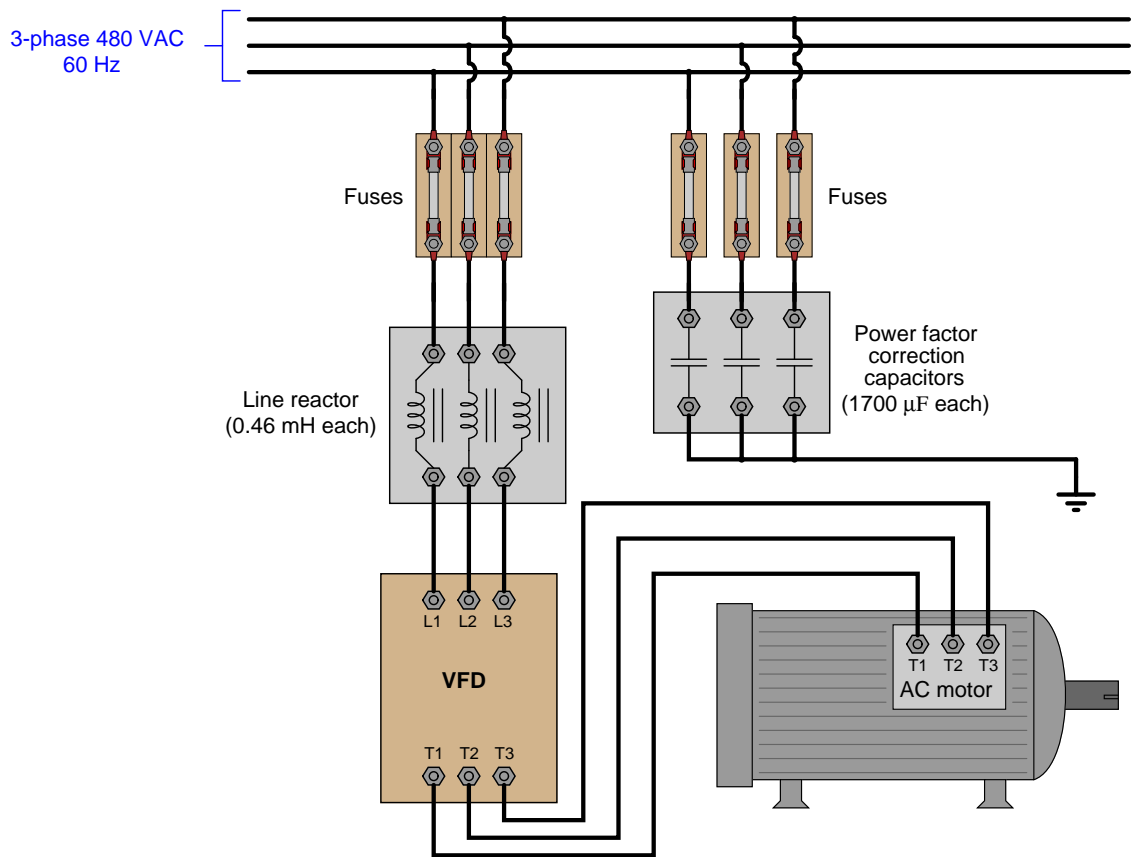

Calculate the resonant frequency of the circuit formed by the reactor coils and power factor correction capacitors, then determine whether or not resonance will be a problem in this system. Explain why or why not, showing all your mathematical work. Note: for the sake of simplicity, you may model each resonant circuit as simple pairs of one reactor coil and one capacitor in series with each other.

#### Challenges

- Is it possible to avoid this resonance problem by programming the VFD with certain *skip frequency* values? Why or why not?

- What purpose do the capacitors serve in this system? Can we safely eliminate them from the circuit?

### 6.2.6 Limited-adjustment speed potentiometer

The following variable-speed motor drive receives a variable DC voltage from a potentiometer as a speed-command signal from a human operator. In this case, the potentiometer's full range commands the motor to spin from 0 RPM to 1800 RPM (the wiper here is drawn in a position nearer 100% speed):

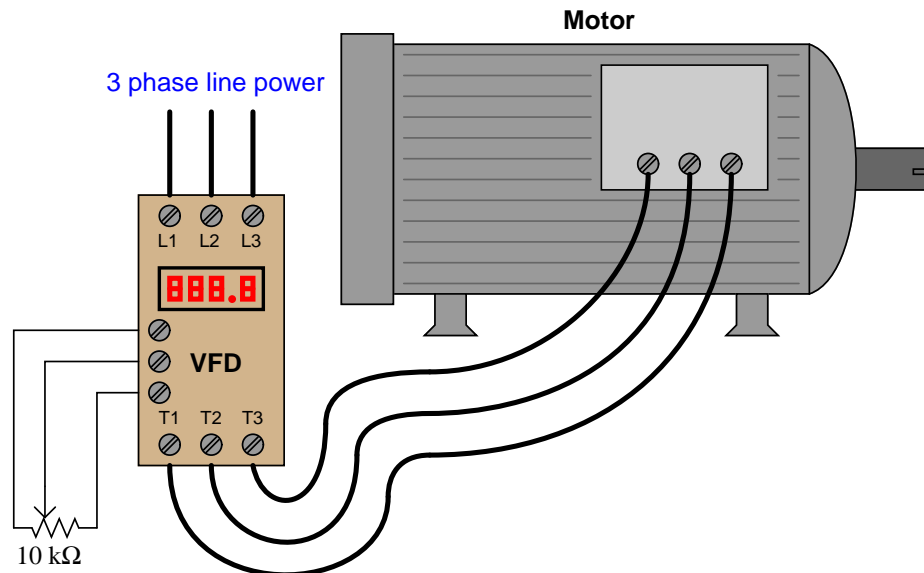

One day the operations manager approaches you to request you modify this speed-command system so that the operators cannot call for a speed less than 100 RPM or greater than 1670 RPM. You consult the manual for the motor drive, and are surprised to find it lacks this sort of capability: a resistance input of 0 to 10 k $\Omega$  will *only* translate to a speed range of 0 to 1800 RPM. This means you must figure out a way to set the adjustable speed range limits externally to the drive (i.e. by limiting the range of the potentiometer's resistance adjustment).

You know you cannot mechanically limit the turning of the potentiometer knob, but you can connect fixed-value resistors to the potentiometer to *electrically* limit its range, so that full clockwise will only command the drive to go as high as 1670 RPM, and full-counterclockwise will only command the drive to go as low as 100 RPM.

Modify this diagram to include any necessary fixed-value resistors, and also calculate their necessary values.

## 6.3 Diagnostic reasoning

These questions are designed to stimulate your deductive and inductive thinking, where you must apply general principles to specific scenarios (deductive) and also derive conclusions about the failed circuit from specific details (inductive). In a Socratic discussion with your instructor, the goal is for these questions to reinforce your recall and use of general circuit principles and also challenge your ability to integrate multiple symptoms into a sensible explanation of what's wrong in a circuit. Your instructor may also pose additional questions based on those assigned, in order to further challenge and sharpen your diagnostic abilities.

As always, your goal is to fully *explain* your analysis of each problem. Simply obtaining a correct answer is not good enough – you must also demonstrate sound reasoning in order to successfully complete the assignment. Your instructor's responsibility is to probe and challenge your understanding of the relevant principles and analytical processes in order to ensure you have a strong foundation upon which to build further understanding.

You will note a conspicuous lack of answers given for these diagnostic questions. Unlike standard textbooks where answers to every other question are given somewhere toward the back of the book, here in these learning modules students must rely on other means to check their work. The best way by far is to debate the answers with fellow students and also with the instructor during the Socratic dialogue sessions intended to be used with these learning modules. Reasoning through challenging questions with other people is an excellent tool for developing strong reasoning skills.

Another means of checking your diagnostic answers, where applicable, is to use circuit simulation software to explore the effects of faults placed in circuits. For example, if one of these diagnostic questions requires that you predict the effect of an open or a short in a circuit, you may check the validity of your work by simulating that same fault (substituting a very high resistance in place of that component for an open, and substituting a very low resistance for a short) within software and seeing if the results agree.

### 6.3.1 Predicting effects of VFD component faults

Predict the effects of each of these problems, considered one at a time:

- Dynamic braking resistor failed open
- Input line reactor failed open on three-phase source
- One diode inside VFD's rectifier section failed open
- Improper V/Hz profile configuration

#### Challenges

- For each of these problems, is there a temporary work-around that might suffice before repairs can be made?



## Chapter 7

# Projects and Experiments

The following project and experiment descriptions outline things you can build to help you understand circuits. With any real-world project or experiment there exists the potential for physical harm. *Electricity can be very dangerous in certain circumstances, and you should follow proper safety precautions at all times!*

### 7.1 Recommended practices

This section outlines some recommended practices for all circuits you design and construct.



### 7.1.1 Safety first!

Electricity, when passed through the human body, causes uncomfortable sensations and in large enough measures<sup>1</sup> will cause muscles to involuntarily contract. The overriding of your nervous system by the passage of electrical current through your body is particularly dangerous in regard to your heart, which is a vital muscle. Very large amounts of current can produce serious internal burns in addition to all the other effects.

Cardio-pulmonary resuscitation (CPR) is the standard first-aid for any victim of electrical shock. This is a very good skill to acquire if you intend to work with others on dangerous electrical circuits. You should never perform tests or work on such circuits unless someone else is present who is proficient in CPR.

As a general rule, any voltage in excess of 30 Volts poses a definitive electric shock hazard, because beyond this level human skin does not have enough resistance to safely limit current through the body. “Live” work of any kind with circuits over 30 volts should be avoided, and if unavoidable should only be done using electrically insulated tools and other protective equipment (e.g. insulating shoes and gloves). If you are unsure of the hazards, or feel unsafe at any time, stop all work and distance yourself from the circuit!

A policy I strongly recommend for students learning about electricity is to *never come into electrical contact<sup>2</sup> with an energized conductor, no matter what the circuit’s voltage<sup>3</sup> level!* Enforcing this policy may seem ridiculous when the circuit in question is powered by a single battery smaller than the palm of your hand, but it is precisely this instilled habit which will save a person from bodily harm when working with more dangerous circuits. Experience has taught me that students who learn early on to be careless with safe circuits have a tendency to be careless later with dangerous circuits!

In addition to the electrical hazards of shock and burns, the construction of projects and running of experiments often poses other hazards such as working with hand and power tools, potential

---

<sup>1</sup>Professor Charles Dalziel published a research paper in 1961 called “The Deleterious Effects of Electric Shock” detailing the results of electric shock experiments with both human and animal subjects. The threshold of perception for human subjects holding a conductor in their hand was in the range of 1 milliamperes of current (less than this for alternating current, and generally less for female subjects than for male). Loss of muscular control was exhibited by half of Dalziel’s subjects at less than 10 milliamperes alternating current. Extreme pain, difficulty breathing, and loss of all muscular control occurred for over 99% of his subjects at direct currents less than 100 milliamperes and alternating currents less than 30 milliamperes. In summary, it doesn’t require much electric current to induce painful and even life-threatening effects in the human body! Your first and best protection against electric shock is maintaining an insulating barrier between your body and the circuit in question, such that current from that circuit will be unable to flow through your body.

<sup>2</sup>By “electrical contact” I mean either directly touching an energized conductor with any part of your body, or indirectly touching it through a conductive tool. The only physical contact you should ever make with an energized conductor is via an electrically insulated tool, for example a screwdriver with an electrically insulated handle, or an insulated test probe for some instrument.

<sup>3</sup>Another reason for consistently enforcing this policy, even on low-voltage circuits, is due to the dangers that even some low-voltage circuits harbor. A single 12 Volt automobile battery, for example, can cause a surprising amount of damage if short-circuited simply due to the high current levels (i.e. very low internal resistance) it is capable of, even though the voltage level is too low to cause a shock through the skin. Mechanics wearing metal rings, for example, are at risk from severe burns if their rings happen to short-circuit such a battery! Furthermore, even when working on circuits that are simply too low-power (low voltage and low current) to cause any bodily harm, touching them while energized can pose a threat to the circuit components themselves. In summary, it generally wise (and *always* a good habit to build) to “power down” *any* circuit before making contact between it and your body.

contact with high temperatures, potential chemical exposure, etc. You should never proceed with a project or experiment if you are unaware of proper tool use or lack basic protective measures (e.g. personal protective equipment such as safety glasses) against such hazards.

Some other safety-related practices should be followed as well:

- All power conductors extending outward from the project must be *firmly* strain-relieved (e.g. “cord grips” used on line power cords), so that an accidental tug or drop will not compromise circuit integrity.
- All electrical connections must be sound and appropriately made (e.g. soldered wire joints rather than twisted-and-taped; terminal blocks rather than solderless breadboards for high-current or high-voltage circuits). Use “touch-safe” terminal connections with recessed metal parts to minimize risk of accidental contact.
- Always provide overcurrent protection in any circuit you build. *Always*. This may be in the form of a fuse, a circuit breaker, and/or an electronically current-limited power supply.
- Always ensure circuit conductors are rated for more current than the overcurrent protection limit. *Always*. A fuse does no good if the wire or printed circuit board trace will “blow” before it does!
- Always bond metal enclosures to Earth ground for any line-powered circuit. *Always*. Ensuring an equipotential state between the enclosure and Earth by making the enclosure electrically common with Earth ground ensures no electric shock can occur simply by one’s body bridging between the Earth and the enclosure.
- Avoid building a high-energy circuit when a low-energy circuit will suffice. For example, I always recommend beginning students power their first DC resistor circuits using small batteries rather than with line-powered DC power supplies. The intrinsic energy limitations of a dry-cell battery make accidents highly unlikely.
- Use line power receptacles that are GFCI (Ground Fault Current Interrupting) to help avoid electric shock from making accidental contact with a “hot” line conductor.
- Always wear eye protection when working with tools or live systems having the potential to eject material into the air. Examples of such activities include soldering, drilling, grinding, cutting, wire stripping, working on or near energized circuits, etc.
- Always use a step-stool or stepladder to reach high places. Never stand on something not designed to support a human load.
- When in doubt, *ask an expert*. If anything even seems remotely unsafe to you, do not proceed without consulting a trusted person fully knowledgeable in electrical safety.

### 7.1.2 Other helpful tips

Experience has shown the following practices to be very helpful, especially when students make their own component selections, to ensure the circuits will be well-behaved:

- Avoid resistor values less than 1 k $\Omega$  or greater than 100 k $\Omega$ , unless such values are definitely necessary<sup>4</sup>. Resistances below 1 k $\Omega$  may draw excessive current if directly connected to a voltage source of significant magnitude, and may also complicate the task of accurately measuring current since any ammeter's non-zero resistance inserted in series with a low-value circuit resistor will significantly alter the total resistance and thereby skew the measurement. Resistances above 100 k $\Omega$  may complicate the task of measuring voltage since any voltmeter's finite resistance connected in parallel with a high-value circuit resistor will significantly alter the total resistance and thereby skew the measurement. Similarly, AC circuit impedance values should be between 1 k $\Omega$  and 100 k $\Omega$ , and for all the same reasons.
- Ensure all electrical connections are low-resistance and physically rugged. For this reason, one should avoid *compression splices* (e.g. "butt" connectors), solderless breadboards<sup>5</sup>, and wires that are simply twisted together.
- Build your circuit with **testing** in mind. For example, provide convenient connection points for test equipment (e.g. multimeters, oscilloscopes, signal generators, logic probes).
- Design permanent projects with **maintenance** in mind. The more convenient you make maintenance tasks, the more likely they will get done.
- **Always document and save your work.** Circuits lacking schematic diagrams are more difficult to troubleshoot than documented circuits. Similarly, circuit construction is simpler when a schematic diagram precedes construction. Experimental results are easier to interpret when comprehensively recorded. Consider modern videorecording technology for this purpose where appropriate.
- **Record your steps** when troubleshooting. **Talk to yourself** when solving problems. These simple steps clarify thought and simplify identification of errors.

---

<sup>4</sup>An example of a necessary resistor value much less than 1 k $\Omega$  is a *shunt resistor* used to produce a small voltage drop for the purpose of sensing current in a circuit. Such shunt resistors must be low-value in order not to impose an undue load on the rest of the circuit. An example of a necessary resistor value much greater than 100 k $\Omega$  is an electrostatic *drain resistor* used to dissipate stored electric charges from body capacitance for the sake of preventing damage to sensitive semiconductor components, while also preventing a path for current that could be dangerous to the person (i.e. shock).

<sup>5</sup>Admittedly, solderless breadboards are very useful for constructing complex electronic circuits with many components, especially DIP-style integrated circuits (ICs), but they tend to give trouble with connection integrity after frequent use. An alternative for projects using low counts of ICs is to solder IC sockets into prototype printed circuit boards (PCBs) and run wires from the soldered pins of the IC sockets to terminal blocks where reliable temporary connections may be made.

### 7.1.3 Terminal blocks for circuit construction

Terminal blocks are the standard means for making electric circuit connections in industrial systems. They are also quite useful as a learning tool, and so I highly recommend their use in lieu of solderless breadboards<sup>6</sup>. Terminal blocks provide highly reliable connections capable of withstanding significant voltage and current magnitudes, and they force the builder to think very carefully about component layout which is an important mental practice. Terminal blocks that mount on standard 35 mm DIN rail<sup>7</sup> are made in a wide range of types and sizes, some with built-in disconnecting switches, some with built-in components such as rectifying diodes and fuseholders, all of which facilitate practical circuit construction.

I recommend every student of electricity build their own terminal block array for use in constructing experimental circuits, consisting of several terminal blocks where each block has at least 4 connection points all electrically common to each other<sup>8</sup> and at least one terminal block that is a fuse holder for overcurrent protection. A pair of anchoring blocks hold all terminal blocks securely on the DIN rail, preventing them from sliding off the rail. Each of the terminals should bear a number, starting from 0. An example is shown in the following photograph and illustration:

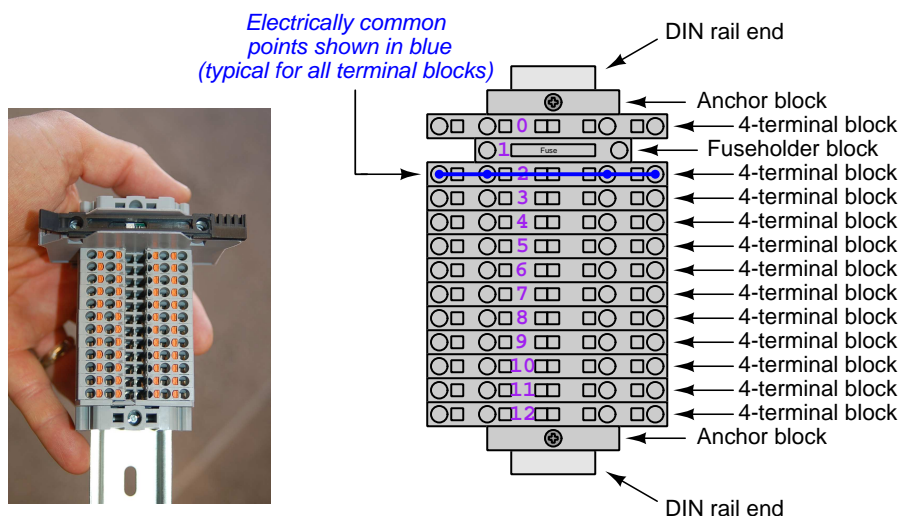

Screwless terminal blocks (using internal spring clips to clamp wire and component lead ends) are preferred over screw-based terminal blocks, as they reduce assembly and disassembly time, and also minimize repetitive wrist stress from twisting screwdrivers. Some screwless terminal blocks require the use of a special tool to release the spring clip, while others provide buttons<sup>9</sup> for this task which may be pressed using the tip of any suitable tool.

<sup>6</sup>Solderless breadboard are preferable for complicated electronic circuits with multiple integrated “chip” components, but for simpler circuits I find terminal blocks much more practical. An alternative to solderless breadboards for “chip” circuits is to solder chip sockets onto a PCB and then use wires to connect the socket pins to terminal blocks. This also accommodates *surface-mount* components, which solderless breadboards do not.

<sup>7</sup>DIN rail is a metal rail designed to serve as a mounting point for a wide range of electrical and electronic devices such as terminal blocks, fuses, circuit breakers, relay sockets, power supplies, data acquisition hardware, etc.

<sup>8</sup>Sometimes referred to as *equipotential*, *same-potential*, or *potential distribution* terminal blocks.

<sup>9</sup>The small orange-colored squares seen in the above photograph are buttons for this purpose, and may be actuated by pressing with any tool of suitable size.

The following example shows how such a terminal block array might be used to construct a series-parallel resistor circuit consisting of four resistors and a battery:

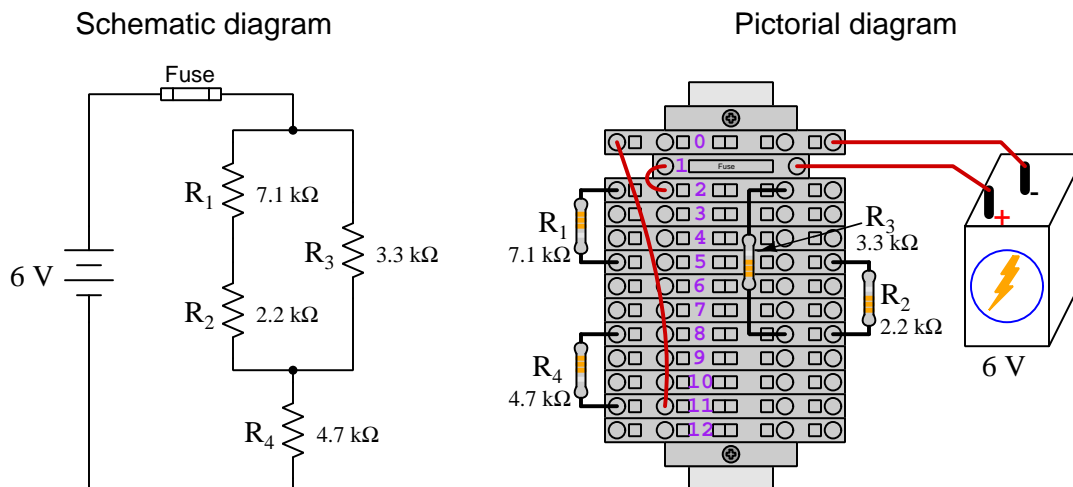

Numbering on the terminal blocks provides a very natural translation to SPICE<sup>10</sup> netlists, where component connections are identified by terminal number:

```
* Series-parallel resistor circuit
v1 1 0 dc 6
r1 2 5 7100
r2 5 8 2200
r3 2 8 3300
r4 8 11 4700
rjmp1 1 2 0.01
rjmp2 0 11 0.01
.op
.end
```

Note the use of “jumper” resistances `rjmp1` and `rjmp2` to describe the wire connections between terminals 1 and 2 and between terminals 0 and 11, respectively. Being resistances, SPICE requires a resistance value for each, and here we see they have both been set to an arbitrarily low value of 0.01 Ohm realistic for short pieces of wire.

Listing all components and wires along with their numbered terminals happens to be a useful documentation method for any circuit built on terminal blocks, independent of SPICE. Such a “wiring sequence” may be thought of as a *non-graphical description* of an electric circuit, and is exceptionally easy to follow.

<sup>10</sup>SPICE is computer software designed to analyze electrical and electronic circuits. Circuits are described for the computer in the form of *netlists* which are text files listing each component type, connection node numbers, and component values.

An example of a more elaborate terminal block array is shown in the following photograph, with terminal blocks and “ice-cube” style electromechanical relays mounted to DIN rail, which is turn mounted to a perforated subpanel<sup>11</sup>. This “terminal block board” hosts an array of thirty five undedicated terminal block sections, four SPDT toggle switches, four DPDT “ice-cube” relays, a step-down control power transformer, bridge rectifier and filtering capacitor, and several fuses for overcurrent protection:

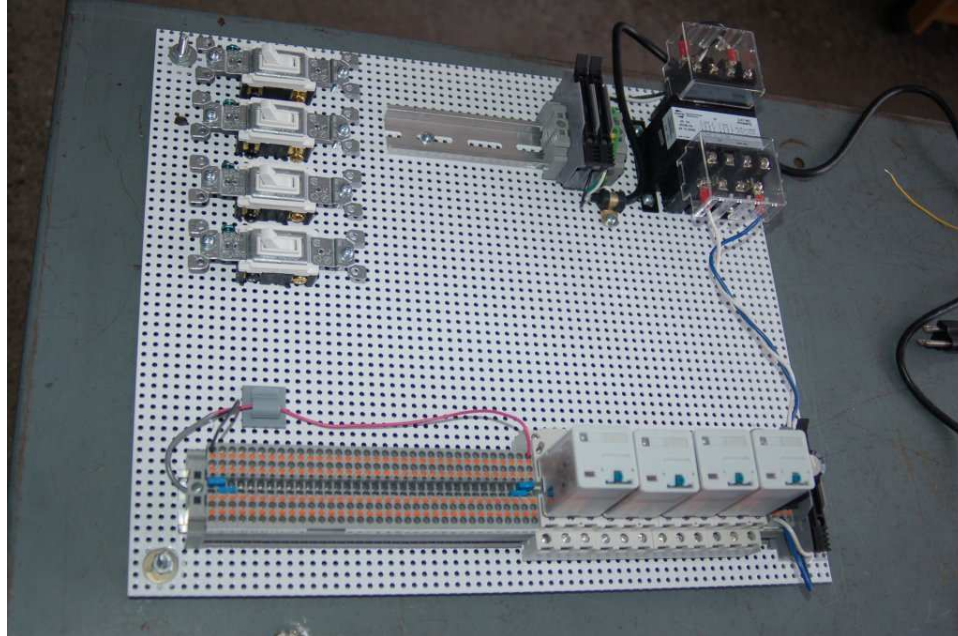

Four plastic-bottomed “feet” support the subpanel above the benchtop surface, and an unused section of DIN rail stands ready to accept other components. Safety features include electrical bonding of the AC line power cord’s ground to the metal subpanel (and all metal DIN rails), mechanical strain relief for the power cord to isolate any cord tension from wire connections, clear plastic finger guards covering the transformer’s screw terminals, as well as fused overcurrent protection for the 120 Volt AC line power and the transformer’s 12 Volt AC output. The perforated holes happen to be on  $\frac{1}{4}$  inch centers with a diameter suitable for tapping with 6-32 machine screw threads, their presence making it very easy to attach other sections of DIN rail, printed circuit boards, or specialized electrical components directly to the grounded metal subpanel. Such a “terminal block board” is an inexpensive<sup>12</sup> yet highly flexible means to construct physically robust circuits using industrial wiring practices.

<sup>11</sup>An electrical *subpanel* is a thin metal plate intended for mounting inside an electrical enclosure. Components are attached to the subpanel, and the subpanel in turn bolts inside the enclosure. Subpanels allow circuit construction outside the confines of the enclosure, which speeds assembly. In this particular usage there is no enclosure, as the subpanel is intended to be used as an open platform for the convenient construction of circuits on a benchtop by students. In essence, this is a modern version of the traditional *breadboard* which was literally a wooden board such as might be used for cutting loaves of bread, but which early electrical and electronic hobbyists used as platforms for the construction of circuits.

<sup>12</sup>At the time of this writing (2019) the cost to build this board is approximately \$250 US dollars.

### 7.1.4 Conducting experiments

An *experiment* is an exploratory act, a test performed for the purpose of assessing some proposition or principle. Experiments are the foundation of the *scientific method*, a process by which careful observation helps guard against errors of speculation. All good experiments begin with an *hypothesis*, defined by the American Heritage Dictionary of the English Language as:

An assertion subject to verification or proof, as (a) A proposition stated as a basis for argument or reasoning. (b) A premise from which a conclusion is drawn. (c) A conjecture that accounts, within a theory or ideational framework, for a set of facts and that can be used as a basis for further investigation.

Stated plainly, an hypothesis is an *educated guess* about cause and effect. The correctness of this initial guess matters little, because any well-designed experiment will reveal the truth of the matter. In fact, *incorrect* hypotheses are often the most valuable because the experiments they engender lead us to surprising discoveries. One of the beautiful aspects of science is that it is more focused on the process of *learning* than about the status of *being correct*<sup>13</sup>. In order for an hypothesis to be valid, it must be testable<sup>14</sup>, which means it must be a claim possible to refute given the right data. Hypotheses impossible to critique are useless.

Once an hypothesis has been formulated, an experiment must be designed to test that hypothesis. A well-designed experiment requires careful regulation of all relevant variables, both for personal safety and for prompting the hypothesized results. If the effects of one particular variable are to be tested, the experiment must be run multiple times with different values of (only) that particular variable. The experiment set up with the “baseline” variable set is called the *control*, while the experiment set up with different value(s) is called the *test* or *experimental*.

For some hypotheses a viable alternative to a physical experiment is a *computer-simulated experiment* or even a *thought experiment*. Simulations performed on a computer test the hypothesis against the physical laws encoded within the computer simulation software, and are particularly useful for students learning new principles for which simulation software is readily available<sup>15</sup>.

<sup>13</sup>Science is more about clarifying our view of the universe through a systematic process of error detection than it is about proving oneself to be right. Some *scientists* may happen to have large egos – and this may have more to do with the ways in which large-scale scientific research is *funded* than anything else – but *scientific method* itself is devoid of ego, and if embraced as a practical philosophy is quite an effective stimulant for humility. Within the education system, scientific method is particularly valuable for helping students break free of the crippling fear of *being wrong*. So much emphasis is placed in formal education on assessing correct retention of facts that many students are fearful of saying or doing anything that might be perceived as a mistake, and of course making mistakes (i.e. having one’s hypotheses disproven by experiment) is an indispensable tool for learning. Introducing science in the classroom – *real* science characterized by individuals forming actual hypotheses and testing those hypotheses by experiment – helps students become self-directed learners.

<sup>14</sup>This is the principle of *falsifiability*: that a scientific statement has value only insofar as it is liable to disprove given the requisite experimental evidence. Any claim that is unfalsifiable – that is, a claim which can *never* be disproven by any evidence whatsoever – could be completely wrong and we could never know it.

<sup>15</sup>A very pertinent example of this is learning how to analyze electric circuits using simulation software such as SPICE. A typical experimental cycle would proceed as follows: (1) Find or invent a circuit to analyze; (2) Apply your analytical knowledge to that circuit, predicting all voltages, currents, powers, etc. relevant to the concepts you are striving to master; (3) Run a simulation on that circuit, collecting “data” from the computer when complete; (4) Evaluate whether or not your hypotheses (i.e. predicted voltages, currents, etc.) agree with the computer-generated results; (5) If so, your analyses are (provisionally) correct – if not, examine your analyses and the computer simulation again to determine the source of error; (6) Repeat this process as many times as necessary until you achieve mastery.

Thought experiments are useful for detecting inconsistencies within your own understanding of some subject, rather than testing your understanding against physical reality.

Here are some general guidelines for conducting experiments:

- The clearer and more specific the hypothesis, the better. Vague or unfalsifiable hypotheses are useless because they will fit *any* experimental results, and therefore the experiment cannot teach you anything about the hypothesis.
- Collect as much data (i.e. information, measurements, sensory experiences) generated by an experiment as is practical. This includes the time and date of the experiment, too!
- *Never* discard or modify data gathered from an experiment. If you have reason to believe the data is unreliable, write notes to that effect, but never throw away data just because you think it is untrustworthy. It is quite possible that even “bad” data holds useful information, and that someone else may be able to uncover its value even if you do not.
- Prioritize *quantitative* data over *qualitative* data wherever practical. Quantitative data is more specific than qualitative, less prone to subjective interpretation on the part of the experimenter, and amenable to an arsenal of analytical methods (e.g. statistics).
- Guard against your own bias(es) by making your experimental results available to others. This allows other people to scrutinize your experimental design and collected data, for the purpose of detecting and correcting errors you may have missed. Document your experiment such that others may independently replicate it.
- Always be looking for sources of error. No physical measurement is perfect, and so it is impossible to achieve *exact* values for any variable. Quantify the amount of uncertainty (i.e. the “tolerance” of errors) whenever possible, and be sure your hypothesis does not depend on precision better than this!
- Always remember that scientific confirmation is provisional – no number of “successful” experiments will prove an hypothesis true for all time, but a single experiment can disprove it. Put into simpler terms, *truth is elusive but error is within reach*.
- Remember that scientific method is about *learning*, first and foremost. An unfortunate consequence of scientific triumph in modern society is that science is often viewed by non-practitioners as an unerring source of truth, when in fact science is an ongoing process of challenging existing ideas to probe for errors and oversights. This is why it is perfectly acceptable to have a failed hypothesis, and why the only truly failed experiment is one where nothing was learned.



The following is an example of a well-planned and executed experiment, in this case a physical experiment demonstrating Ohm's Law.

Planning Time/Date = 09:30 on 12 February 2019

HYPOTHESIS: the current through any resistor should be exactly proportional to the voltage impressed across it.

PROCEDURE: connect a resistor rated 1 k Ohm and 1/4 Watt to a variable-voltage DC power supply. Use an ammeter in series to measure resistor current and a voltmeter in parallel to measure resistor voltage.

RISKS AND MITIGATION: excessive power dissipation may harm the resistor and/or pose a burn hazard, while excessive voltage poses an electric shock hazard. 30 Volts is a safe maximum voltage for laboratory practices, and according to Joule's Law a 1000 Ohm resistor will dissipate 0.25 Watts at 15.81 Volts ( $P = V^2 / R$ ), so I will remain below 15 Volts just to be safe.

Experiment Time/Date = 10:15 on 12 February 2019

DATA COLLECTED:

(Voltage)	(Current)	(Voltage)	(Current)
0.000 V	= 0.000 mA	8.100	= 7.812 mA
2.700 V	= 2.603 mA	10.00 V	= 9.643 mA
5.400 V	= 5.206 mA	14.00 V	= 13.49 mA

Analysis Time/Date = 10:57 on 12 February 2019

ANALYSIS: current definitely increases with voltage, and although I expected exactly one milliAmpere per Volt the actual current was usually less than that. The voltage/current ratios ranged from a low of 1036.87 (at 8.1 Volts) to a high of 1037.81 (at 14 Volts), but this represents a variance of only -0.0365% to +0.0541% from the average, indicating a very consistent proportionality -- results consistent with Ohm's Law.

ERROR SOURCES: one major source of error is the resistor's value itself. I did not measure it, but simply assumed color bands of brown-black-red meant exactly 1000 Ohms. Based on the data I think the true resistance is closer to 1037 Ohms. Another possible explanation is multimeter calibration error. However, neither explains the small positive and negative variances from the average. This might be due to electrical noise, a good test being to repeat the same experiment to see if the variances are the same or different. Noise should generate slightly different results every time.

The following is an example of a well-planned and executed *virtual* experiment, in this case demonstrating Ohm's Law using a computer (SPICE) simulation.

Planning Time/Date = 12:32 on 14 February 2019

HYPOTHESIS: for any given resistor, the current through that resistor should be exactly proportional to the voltage impressed across it.

PROCEDURE: write a SPICE netlist with a single DC voltage source and single 1000 Ohm resistor, then use NGSPICE version 26 to perform a "sweep" analysis from 0 Volts to 25 Volts in 5 Volt increments.

```
* SPICE circuit
v1 1 0 dc
r1 1 0 1000
.dc v1 0 25 5
.print dc v(1) i(v1)
.end
```

RISKS AND MITIGATION: none.

DATA COLLECTED:

DC transfer characteristic Thu Feb 14 13:05:08 2019

Index	v-sweep	v(1)	v1#branch
0	0.000000e+00	0.000000e+00	0.000000e+00
1	5.000000e+00	5.000000e+00	-5.00000e-03
2	1.000000e+01	1.000000e+01	-1.00000e-02
3	1.500000e+01	1.500000e+01	-1.50000e-02
4	2.000000e+01	2.000000e+01	-2.00000e-02
5	2.500000e+01	2.500000e+01	-2.50000e-02

Analysis Time/Date = 13:06 on 14 February 2019

ANALYSIS: perfect agreement between data and hypothesis -- current is precisely 1/1000 of the applied voltage for all values. Anything other than perfect agreement would have probably meant my netlist was incorrect. The negative current values surprised me, but it seems this is just how SPICE interprets normal current through a DC voltage source.

ERROR SOURCES: none.

As gratuitous as it may seem to perform experiments on a physical law as well-established as Ohm's Law, even the examples listed previously demonstrate opportunity for real learning. In the physical experiment example, the student should identify and explain why their data does not perfectly agree with the hypothesis, and this leads them naturally to consider sources of error. In the computer-simulated experiment, the student is struck by SPICE's convention of denoting regular current through a DC voltage source as being *negative* in sign, and this is also useful knowledge for future simulations. Scientific experiments are most interesting when things *do not* go as planned!

Aside from verifying well-established physical laws, simple experiments are extremely useful as educational tools for a wide range of purposes, including:

- Component familiarization (e.g. *Which terminals of this switch connect to the NO versus NC contacts?*)
- System testing (e.g. *How heavy of a load can my AC-DC power supply source before the semiconductor components reach their thermal limits?*)
- Learning programming languages (e.g. *Let's try to set up an "up" counter function in this PLC!*)

Above all, the priority here is to inculcate the habit of hypothesizing, running experiments, and analyzing the results. This experimental cycle not only serves as an excellent method for self-directed learning, but it also works exceptionally well for troubleshooting faults in complex systems, and for these reasons should be a part of every technician's and every engineer's education.

### 7.1.5 Constructing projects

Designing, constructing, and testing projects is a very effective means of practical education. Within a formal educational setting, projects are generally chosen (or at least vetted) by an instructor to ensure they may be reasonably completed within the allotted time of a course or program of study, and that they sufficiently challenge the student to learn certain important principles. In a self-directed environment, projects are just as useful as a learning tool but there is some risk of unwittingly choosing a project beyond one's abilities, which can lead to frustration.

Here are some general guidelines for managing projects:

- Define your goal(s) before beginning a project: what do you wish to achieve in building it? What, exactly, should the completed project *do*?
- Analyze your project prior to construction. Document it in appropriate forms (e.g. schematic diagrams), predict its functionality, anticipate all associated risks. In other words, *plan ahead*.
- Set a reasonable budget for your project, and stay within it.
- Identify any deadlines, and set reasonable goals to meet those deadlines.
- Beware of *scope creep*: the tendency to modify the project's goals before it is complete.
- Document your progress! An easy way to do this is to use photography or videography: take photos and/or videos of your project as it progresses. Document failures as well as successes, because both are equally valuable from the perspective of learning.

## 7.2 Experiment: DC injection braking

Devise and execute an experiment demonstrating the principle of DC injection braking on a small AC induction motor, showing how the motor acts as a brake when its shaft is turned by hand and DC is “injected” into its stator winding. There is no need to equip this motor to run as an AC motor – this experiment merely demonstrates *braking*, not running and braking.

### EXPERIMENT CHECKLIST:

- Prior to experimentation:
  - Write an hypothesis (i.e. a detailed description of what you expect will happen) unambiguous enough that it could be disproven given the right data.
  - Write a procedure to test the hypothesis, complete with adequate controls and documentation (e.g. schematic diagrams, programming code).
  - Identify any risks (e.g. shock hazard, component damage) and write a mitigation plan based on best practices and component ratings.
- During experimentation:
  - Safe practices followed at all times (e.g. no contact with energized circuit).
  - Correct equipment usage according to manufacturer’s recommendations.
  - All data collected, ideally quantitative with full precision (i.e. no rounding).
- After each experimental run:
  - If the results fail to match the hypothesis, identify the error(s), correct the hypothesis and/or revise the procedure, and re-run the experiment.
  - Identify any uncontrolled sources of error in the experiment.
- After all experimental re-runs:
  - Save all data for future reference.
  - Write an analysis of experimental results and lessons learned.

### Challenges

- Science is an *iterative* process, and for this reason is never complete. Following the results of your experiment, what would you propose for your *next* hypothesis and *next* experimental procedure? Hint: if your experiment produced any unexpected results, exploring those unexpected results is often a very good basis for the next experiment!

### 7.3 Experiment: AC motor starter with DC injection braking

Devise and execute an experiment demonstrating a small AC motor being started, run, and “braking” applied to bring it to a swift halt using the DC injection method.

#### EXPERIMENT CHECKLIST:

- Prior to experimentation:
  - Write an hypothesis (i.e. a detailed description of what you expect will happen) unambiguous enough that it could be disproven given the right data.
  - Write a procedure to test the hypothesis, complete with adequate controls and documentation (e.g. schematic diagrams, programming code).
  - Identify any risks (e.g. shock hazard, component damage) and write a mitigation plan based on best practices and component ratings.
- During experimentation:
  - Safe practices followed at all times (e.g. no contact with energized circuit).
  - Correct equipment usage according to manufacturer’s recommendations.
  - All data collected, ideally quantitative with full precision (i.e. no rounding).
- After each experimental run:
  - If the results fail to match the hypothesis, identify the error(s), correct the hypothesis and/or revise the procedure, and re-run the experiment.
  - Identify any uncontrolled sources of error in the experiment.
- After all experimental re-runs:
  - Save all data for future reference.
  - Write an analysis of experimental results and lessons learned.

#### Challenges

- Science is an *iterative* process, and for this reason is never complete. Following the results of your experiment, what would you propose for your *next* hypothesis and *next* experimental procedure? Hint: if your experiment produced any unexpected results, exploring those unexpected results is often a very good basis for the next experiment!

## 7.4 Project: VFD-controlled AC induction motor

Wire and configure a variable-frequency motor drive (VFD) to control the speed of a fractional horsepower AC induction motor. VFDs provide provision for starting and stopping the motor, varying its speed, reversing direction, and limiting acceleration and deceleration rates, among other things. A large selection of VFDs suitable for powering with 120 VAC single-phase line power are readily available at low cost, as are fractional-horsepower three-phase “inverter-duty” induction motors.

Common control options for VFDs include the following:

- Start/stop control from the VFD’s front panel
- Start/stop control using remote switches
- Start/stop control via digital network
- Speed control from the VFD’s front panel
- Speed control using remote potentiometer
- Speed control using remote analog voltage or current signal
- Speed control via digital network

### PROJECT CHECKLIST:

- Prior to construction:
  - Prototype diagram(s) and description of project scope.
  - Risk assessment/mitigation plan.
  - Timeline and action plan.
- During construction:
  - Safe work habits (e.g. no contact made with energized circuit at any time).
  - Correct equipment usage according to manufacturer’s recommendations.
  - Timeline and action plan amended as necessary.
  - Maintain the originally-planned project scope (i.e. avoid adding features!).
- After completion:
  - All functions tested against original plan.
  - Full, accurate, and appropriate documentation of all project details.
  - Complete bill of materials.
  - Written summary of lessons learned.

Challenges
------------

- ???.
- ???.
- ???.

## Appendix A

# Problem-Solving Strategies

The ability to solve complex problems is arguably one of the most valuable skills one can possess, and this skill is particularly important in any science-based discipline.

- Study principles, not procedures. Don't be satisfied with merely knowing how to compute solutions – learn *why* those solutions work.
- Identify what it is you need to solve, identify all relevant data, identify all units of measurement, identify any general principles or formulae linking the given information to the solution, and then identify any “missing pieces” to a solution. Annotate all diagrams with this data.
- Sketch a diagram to help visualize the problem. When building a real system, always devise a plan for that system and analyze its function *before* constructing it.
- Follow the units of measurement and meaning of every calculation. If you are ever performing mathematical calculations as part of a problem-solving procedure, and you find yourself unable to apply each and every intermediate result to some aspect of the problem, it means you don't understand what you are doing. Properly done, every mathematical result should have practical meaning for the problem, and not just be an abstract number. You should be able to identify the proper units of measurement for each and every calculated result, and show where that result fits into the problem.
- Perform “thought experiments” to explore the effects of different conditions for theoretical problems. When troubleshooting real systems, perform *diagnostic tests* rather than visually inspecting for faults, the best diagnostic test being the one giving you the most information about the nature and/or location of the fault with the fewest steps.
- Simplify the problem until the solution becomes obvious, and then use that obvious case as a model to follow in solving the more complex version of the problem.
- Check for exceptions to see if your solution is incorrect or incomplete. A good solution will work for *all* known conditions and criteria. A good example of this is the process of testing scientific hypotheses: the task of a scientist is not to find support for a new idea, but rather to *challenge* that new idea to see if it holds up under a battery of tests. The philosophical



principle of *reductio ad absurdum* (i.e. disproving a general idea by finding a specific case where it fails) is useful here.

- Work “backward” from a hypothetical solution to a new set of given conditions.
- Add quantities to problems that are qualitative in nature, because sometimes a little math helps illuminate the scenario.
- Sketch graphs illustrating how variables relate to each other. These may be quantitative (i.e. with realistic number values) or qualitative (i.e. simply showing increases and decreases).
- Treat quantitative problems as qualitative in order to discern the relative magnitudes and/or directions of change of the relevant variables. For example, try determining what happens if a certain variable were to increase or decrease before attempting to precisely calculate quantities: how will each of the dependent variables respond, by increasing, decreasing, or remaining the same as before?
- Consider limiting cases. This works especially well for qualitative problems where you need to determine which direction a variable will change. Take the given condition and magnify that condition to an extreme degree as a way of simplifying the direction of the system’s response.
- Check your work. This means regularly testing your conclusions to see if they make sense. This does *not* mean repeating the same steps originally used to obtain the conclusion(s), but rather to use some other means to check validity. Simply repeating procedures often leads to *repeating the same errors* if any were made, which is why alternative paths are better.

## Appendix B

# Instructional philosophy

*“The unexamined circuit is not worth energizing”* – Socrates (if he had taught electricity)

These learning modules, although useful for self-study, were designed to be used in a formal learning environment where a subject-matter expert challenges students to digest the content and exercise their critical thinking abilities in the answering of questions and in the construction and testing of working circuits.

The following principles inform the instructional and assessment philosophies embodied in these learning modules:

- The first goal of education is to enhance clear and independent thought, in order that every student reach their fullest potential in a highly complex and inter-dependent world. Robust reasoning is *always* more important than particulars of any subject matter, because its application is universal.
- Literacy is fundamental to independent learning and thought because text continues to be the most efficient way to communicate complex ideas over space and time. Those who cannot read with ease are limited in their ability to acquire knowledge and perspective.
- Articulate communication is fundamental to work that is complex and interdisciplinary.
- Faulty assumptions and poor reasoning are best corrected through challenge, not presentation. The rhetorical technique of *reductio ad absurdum* (disproving an assertion by exposing an absurdity) works well to discipline student’s minds, not only to correct the problem at hand but also to learn how to detect and correct future errors.
- Important principles should be repeatedly explored and widely applied throughout a course of study, not only to reinforce their importance and help ensure their mastery, but also to showcase the interconnectedness and utility of knowledge.

These learning modules were expressly designed to be used in an “inverted” teaching environment<sup>1</sup> where students first read the introductory and tutorial chapters on their own, then individually attempt to answer the questions and construct working circuits according to the experiment and project guidelines. The instructor never lectures, but instead meets regularly with each individual student to review their progress, answer questions, identify misconceptions, and challenge the student to new depths of understanding through further questioning. Regular meetings between instructor and student should resemble a Socratic<sup>2</sup> dialogue, where questions serve as scalpels to dissect topics and expose assumptions. The student passes each module only after consistently demonstrating their ability to logically analyze and correctly apply all major concepts in each question or project/experiment. The instructor must be vigilant in probing each student’s understanding to ensure they are truly *reasoning* and not just *memorizing*. This is why “Challenge” points appear throughout, as prompts for students to think deeper about topics and as starting points for instructor queries. Sometimes these challenge points require additional knowledge that hasn’t been covered in the series to answer in full. This is okay, as the major purpose of the Challenges is to stimulate analysis and synthesis on the part of each student.

The instructor must possess enough mastery of the subject matter and awareness of students’ reasoning to generate their own follow-up questions to practically any student response. Even completely correct answers given by the student should be challenged by the instructor for the purpose of having students practice articulating their thoughts and defending their reasoning. Conceptual errors committed by the student should be exposed and corrected not by direct instruction, but rather by reducing the errors to an absurdity<sup>3</sup> through well-chosen questions and thought experiments posed by the instructor. Becoming proficient at this style of instruction requires time and dedication, but the positive effects on critical thinking for both student and instructor are spectacular.

An inspection of these learning modules reveals certain unique characteristics. One of these is a bias toward thorough explanations in the tutorial chapters. Without a live instructor to explain concepts and applications to students, the text itself must fulfill this role. This philosophy results in lengthier explanations than what you might typically find in a textbook, each step of the reasoning process fully explained, including footnotes addressing common questions and concerns students raise while learning these concepts. Each tutorial seeks to not only explain each major concept in sufficient detail, but also to explain the logic of each concept and how each may be developed

---

<sup>1</sup>In a traditional teaching environment, students first encounter new information via *lecture* from an expert, and then independently apply that information via *homework*. In an “inverted” course of study, students first encounter new information via *homework*, and then independently apply that information under the scrutiny of an expert. The expert’s role in lecture is to simply *explain*, but the expert’s role in an inverted session is to *challenge, critique*, and if necessary *explain* where gaps in understanding still exist.

<sup>2</sup>Socrates is a figure in ancient Greek philosophy famous for his unflinching style of questioning. Although he authored no texts, he appears as a character in Plato’s many writings. The essence of Socratic philosophy is to leave no question unexamined and no point of view unchallenged. While purists may argue a topic such as electric circuits is too narrow for a true Socratic-style dialogue, I would argue that the essential thought processes involved with scientific reasoning on *any* topic are not far removed from the Socratic ideal, and that students of electricity and electronics would do very well to challenge assumptions, pose thought experiments, identify fallacies, and otherwise employ the arsenal of critical thinking skills modeled by Socrates.

<sup>3</sup>This rhetorical technique is known by the Latin phrase *reductio ad absurdum*. The concept is to expose errors by counter-example, since only one solid counter-example is necessary to disprove a universal claim. As an example of this, consider the common misconception among beginning students of electricity that voltage cannot exist without current. One way to apply *reductio ad absurdum* to this statement is to ask how much current passes through a fully-charged battery connected to nothing (i.e. a clear example of voltage existing without current).

from “first principles”. Again, this reflects the goal of developing clear and independent thought in students’ minds, by showing how clear and logical thought was used to forge each concept. Students benefit from witnessing a model of clear thinking in action, and these tutorials strive to be just that.

Another characteristic of these learning modules is a lack of step-by-step instructions in the Project and Experiment chapters. Unlike many modern workbooks and laboratory guides where step-by-step instructions are prescribed for each experiment, these modules take the approach that students must learn to closely read the tutorials and apply their own reasoning to identify the appropriate experimental steps. Sometimes these steps are plainly declared in the text, just not as a set of enumerated points. At other times certain steps are implied, an example being assumed competence in test equipment use where the student should not need to be told *again* how to use their multimeter because that was thoroughly explained in previous lessons. In some circumstances no steps are given at all, leaving the entire procedure up to the student.

This lack of prescription is not a flaw, but rather a feature. Close reading and clear thinking are foundational principles of this learning series, and in keeping with this philosophy all activities are designed to *require* those behaviors. Some students may find the lack of prescription frustrating, because it demands more from them than what their previous educational experiences required. This frustration should be interpreted as an unfamiliarity with autonomous thinking, a problem which must be corrected if the student is ever to become a self-directed learner and effective problem-solver. Ultimately, the need for students to read closely and think clearly is more important both in the near-term and far-term than any specific facet of the subject matter at hand. If a student takes longer than expected to complete a module because they are forced to outline, digest, and reason on their own, so be it. The future gains enjoyed by developing this mental discipline will be well worth the additional effort and delay.

Another feature of these learning modules is that they do not treat topics in isolation. Rather, important concepts are introduced early in the series, and appear repeatedly as stepping-stones toward other concepts in subsequent modules. This helps to avoid the “compartmentalization” of knowledge, demonstrating the inter-connectedness of concepts and simultaneously reinforcing them. Each module is fairly complete in itself, reserving the beginning of its tutorial to a review of foundational concepts.

This methodology of assigning text-based modules to students for digestion and then using Socratic dialogue to assess progress and hone students’ thinking was developed over a period of several years by the author with his Electronics and Instrumentation students at the two-year college level. While decidedly unconventional and sometimes even unsettling for students accustomed to a more passive lecture environment, this instructional philosophy has proven its ability to convey conceptual mastery, foster careful analysis, and enhance employability so much better than lecture that the author refuses to ever teach by lecture again.

Problems which often go undiagnosed in a lecture environment are laid bare in this “inverted” format where students must articulate and logically defend their reasoning. This, too, may be unsettling for students accustomed to lecture sessions where the instructor cannot tell for sure who comprehends and who does not, and this vulnerability necessitates sensitivity on the part of the “inverted” session instructor in order that students never feel discouraged by having their errors exposed. *Everyone* makes mistakes from time to time, and learning is a lifelong process! Part of the instructor’s job is to build a culture of learning among the students where errors are not seen as shameful, but rather as opportunities for progress.

To this end, instructors managing courses based on these modules should adhere to the following principles:

- Student questions are always welcome and demand thorough, honest answers. The only type of question an instructor should refuse to answer is one the student should be able to easily answer on their own. Remember, *the fundamental goal of education is for each student to learn to think clearly and independently*. This requires hard work on the part of the student, which no instructor should ever circumvent. Anything done to bypass the student's responsibility to do that hard work ultimately limits that student's potential and thereby does real harm.
- It is not only permissible, but encouraged, to answer a student's question by asking questions in return, these follow-up questions designed to guide the student to reach a correct answer through their own reasoning.
- All student answers demand to be challenged by the instructor and/or by other students. This includes both correct and incorrect answers – the goal is to practice the articulation and defense of one's own reasoning.
- No reading assignment is deemed complete unless and until the student demonstrates their ability to accurately summarize the major points in their own terms. Recitation of the original text is unacceptable. This is why every module contains an "Outline and reflections" question as well as a "Foundational concepts" question in the Conceptual reasoning section, to prompt reflective reading.
- No assigned question is deemed answered unless and until the student demonstrates their ability to consistently and correctly apply the concepts to *variations* of that question. This is why module questions typically contain multiple "Challenges" suggesting different applications of the concept(s) as well as variations on the same theme(s). Instructors are encouraged to devise as many of their own "Challenges" as they are able, in order to have a multitude of ways ready to probe students' understanding.
- No assigned experiment or project is deemed complete unless and until the student demonstrates the task in action. If this cannot be done "live" before the instructor, video-recordings showing the demonstration are acceptable. All relevant safety precautions must be followed, all test equipment must be used correctly, and the student must be able to properly explain all results. The student must also successfully answer all Challenges presented by the instructor for that experiment or project.

Students learning from these modules would do well to abide by the following principles:

- No text should be considered fully and adequately read unless and until you can express every idea *in your own words, using your own examples*.
- You should always articulate your thoughts as you read the text, noting points of agreement, confusion, and epiphanies. Feel free to print the text on paper and then write your notes in the margins. Alternatively, keep a journal for your own reflections as you read. This is truly a helpful tool when digesting complicated concepts.
- Never take the easy path of highlighting or underlining important text. Instead, *summarize* and/or *comment* on the text using your own words. This actively engages your mind, allowing you to more clearly perceive points of confusion or misunderstanding on your own.
- A very helpful strategy when learning new concepts is to place yourself in the role of a teacher, if only as a mental exercise. Either explain what you have recently learned to someone else, or at least *imagine* yourself explaining what you have learned to someone else. The simple act of having to articulate new knowledge and skill forces you to take on a different perspective, and will help reveal weaknesses in your understanding.
- Perform each and every mathematical calculation and thought experiment shown in the text on your own, referring back to the text to see that your results agree. This may seem trivial and unnecessary, but it is critically important to ensuring you actually understand what is presented, especially when the concepts at hand are complicated and easy to misunderstand. Apply this same strategy to become proficient in the use of *circuit simulation software*, checking to see if your simulated results agree with the results shown in the text.
- Above all, recognize that learning is hard work, and that a certain level of frustration is unavoidable. There are times when you will struggle to grasp some of these concepts, and that struggle is a natural thing. Take heart that it will yield with persistent and varied<sup>4</sup> effort, and never give up!

Students interested in using these modules for self-study will also find them beneficial, although the onus of responsibility for thoroughly reading and answering questions will of course lie with that individual alone. If a qualified instructor is not available to challenge students, a workable alternative is for students to form study groups where they challenge<sup>5</sup> one another.

To high standards of education,

Tony R. Kuphaldt

---

<sup>4</sup>As the old saying goes, “Insanity is trying the same thing over and over again, expecting different results.” If you find yourself stumped by something in the text, you should attempt a different approach. Alter the thought experiment, change the mathematical parameters, do whatever you can to see the problem in a slightly different light, and then the solution will often present itself more readily.

<sup>5</sup>Avoid the temptation to simply share answers with study partners, as this is really counter-productive to learning. Always bear in mind that the answer to any question is far less important in the long run than the method(s) used to obtain that answer. The goal of education is to empower one’s life through the improvement of clear and independent thought, literacy, expression, and various practical skills.



# Appendix C

## Tools used

I am indebted to the developers of many open-source software applications in the creation of these learning modules. The following is a list of these applications with some commentary on each.

You will notice a theme common to many of these applications: a bias toward *code*. Although I am by no means an expert programmer in any computer language, I understand and appreciate the flexibility offered by code-based applications where the user (you) enters commands into a plain ASCII text file, which the software then reads and processes to create the final output. Code-based computer applications are by their very nature *extensible*, while WYSIWYG (What You See Is What You Get) applications are generally limited to whatever user interface the developer makes for you.

### The GNU/Linux computer operating system

There is so much to be said about Linus Torvalds' `Linux` and Richard Stallman's `GNU` project. First, to credit just these two individuals is to fail to do justice to the *mob* of passionate volunteers who contributed to make this amazing software a reality. I first learned of `Linux` back in 1996, and have been using this operating system on my personal computers almost exclusively since then. It is *free*, it is completely *configurable*, and it permits the continued use of highly efficient `Unix` applications and scripting languages (e.g. shell scripts, Makefiles, `sed`, `awk`) developed over many decades. `Linux` not only provided me with a powerful computing platform, but its open design served to inspire my life's work of creating open-source educational resources.

### Bram Moolenaar's Vim text editor

Writing code for any code-based computer application requires a *text editor*, which may be thought of as a word processor strictly limited to outputting plain-ASCII text files. Many good text editors exist, and one's choice of text editor seems to be a deeply personal matter within the programming world. I prefer `Vim` because it operates very similarly to `vi` which is ubiquitous on `Unix/Linux` operating systems, and because it may be entirely operated via keyboard (i.e. no mouse required) which makes it fast to use.



### Donald Knuth's $\text{\TeX}$ typesetting system

Developed in the late 1970's and early 1980's by computer scientist extraordinaire Donald Knuth to typeset his multi-volume magnum opus *The Art of Computer Programming*, this software allows the production of formatted text for screen-viewing or paper printing, all by writing plain-text code to describe how the formatted text is supposed to appear.  $\text{\TeX}$  is not just a markup language for documents, but it is also a Turing-complete programming language in and of itself, allowing useful algorithms to be created to control the production of documents. Simply put,  *$\text{\TeX}$  is a programmer's approach to word processing*. Since  $\text{\TeX}$  is controlled by code written in a plain-text file, this means anyone may read that plain-text file to see exactly how the document was created. This openness afforded by the code-based nature of  $\text{\TeX}$  makes it relatively easy to learn how other people have created their own  $\text{\TeX}$  documents. By contrast, examining a beautiful document created in a conventional WYSIWYG word processor such as Microsoft **Word** suggests nothing to the reader about *how* that document was created, or what the user might do to create something similar. As Mr. Knuth himself once quipped, conventional word processing applications should be called WYSIAYG (What You See Is *All* You Get).

### Leslie Lamport's $\text{\LaTeX}$ extensions to $\text{\TeX}$

Like all true programming languages,  $\text{\TeX}$  is inherently extensible. So, years after the release of  $\text{\TeX}$  to the public, Leslie Lamport decided to create a massive extension allowing easier compilation of book-length documents. The result was  $\text{\LaTeX}$ , which is the markup language used to create all ModEL module documents. You could say that  $\text{\TeX}$  is to  $\text{\LaTeX}$  as **C** is to **C++**. This means it is permissible to use any and all  $\text{\TeX}$  commands within  $\text{\LaTeX}$  source code, and it all still works. Some of the features offered by  $\text{\LaTeX}$  that would be challenging to implement in  $\text{\TeX}$  include automatic index and table-of-content creation.

### Tim Edwards' **Xcircuit** drafting program

This wonderful program is what I use to create all the schematic diagrams and illustrations (but not photographic images or mathematical plots) throughout the ModEL project. It natively outputs PostScript format which is a true vector graphic format (this is why the images do not pixellate when you zoom in for a closer view), and it is so simple to use that I have never had to read the manual! Object libraries are easy to create for **Xcircuit**, being plain-text files using PostScript programming conventions. Over the years I have collected a large set of object libraries useful for drawing electrical and electronic schematics, pictorial diagrams, and other technical illustrations.

### Gimp graphic image manipulation program

Essentially an open-source clone of Adobe’s **PhotoShop**, I use **Gimp** to resize, crop, and convert file formats for all of the photographic images appearing in the **MODEL** modules. Although **Gimp** does offer its own scripting language (called **Script-Fu**), I have never had occasion to use it. Thus, my utilization of **Gimp** to merely crop, resize, and convert graphic images is akin to using a sword to slice bread.

### SPICE circuit simulation program

**SPICE** is to circuit analysis as **T<sub>E</sub>X** is to document creation: it is a form of markup language designed to describe a certain object to be processed in plain-ASCII text. When the plain-text “source file” is compiled by the software, it outputs the final result. More modern circuit analysis tools certainly exist, but I prefer **SPICE** for the following reasons: it is *free*, it is *fast*, it is *reliable*, and it is a fantastic tool for *teaching* students of electricity and electronics how to write simple code. I happen to use rather old versions of **SPICE**, version 2g6 being my “go to” application when I only require text-based output. **NGSPICE** (version 26), which is based on Berkeley **SPICE** version 3f5, is used when I require graphical output for such things as time-domain waveforms and Bode plots. In all **SPICE** example netlists I strive to use coding conventions compatible with all **SPICE** versions.

### Andrew D. Hwang’s ePiX mathematical visualization programming library

This amazing project is a **C++** library you may link to any **C/C++** code for the purpose of generating PostScript graphic images of mathematical functions. As a completely free and open-source project, it does all the plotting I would otherwise use a Computer Algebra System (CAS) such as **Mathematica** or **Maple** to do. It should be said that **ePiX** is *not* a Computer Algebra System like **Mathematica** or **Maple**, but merely a mathematical *visualization* tool. In other words, it won’t determine integrals for you (you’ll have to implement that in your own **C/C++** code!), but it can graph the results, and it does so beautifully. What I really admire about **ePiX** is that it is a **C++** programming library, which means it builds on the existing power and toolset available with that programming language. Mr. Hwang could have probably developed his own stand-alone application for mathematical plotting, but by creating a **C++** library to do the same thing he accomplished something much greater.

### `gnuplot` mathematical visualization software

Another open-source tool for mathematical visualization is `gnuplot`. Interestingly, this tool is *not* part of Richard Stallman’s GNU project, its name being a coincidence. For this reason the authors prefer “gnu” *not* be capitalized at all to avoid confusion. This is a much “lighter-weight” alternative to a spreadsheet for plotting tabular data, and the fact that it easily outputs directly to an X11 console or a file in a number of different graphical formats (including PostScript) is very helpful. I typically set my `gnuplot` output format to default (X11 on my Linux PC) for quick viewing while I’m developing a visualization, then switch to PostScript file export once the visual is ready to include in the document(s) I’m writing. As with my use of `Gimp` to do rudimentary image editing, my use of `gnuplot` only scratches the surface of its capabilities, but the important points are that it’s *free* and that it *works well*.

### Python programming language

Both Python and C++ find extensive use in these modules as instructional aids and exercises, but I’m listing Python here as a *tool* for myself because I use it almost daily as a *calculator*. If you open a Python interpreter console and type `from math import *` you can type mathematical expressions and have it return results just as you would on a hand calculator. Complex-number (i.e. *phasor*) arithmetic is similarly supported if you include the complex-math library (`from cmath import *`). Examples of this are shown in the Programming References chapter (if included) in each module. Of course, being a fully-featured programming language, Python also supports conditionals, loops, and other structures useful for calculation of quantities. Also, running in a console environment where all entries and returned values show as text in a chronologically-ordered list makes it easy to copy-and-paste those calculations to document exactly how they were performed.

# Appendix D

## Creative Commons License

### Creative Commons Attribution 4.0 International Public License

By exercising the Licensed Rights (defined below), You accept and agree to be bound by the terms and conditions of this Creative Commons Attribution 4.0 International Public License (“Public License”). To the extent this Public License may be interpreted as a contract, You are granted the Licensed Rights in consideration of Your acceptance of these terms and conditions, and the Licensor grants You such rights in consideration of benefits the Licensor receives from making the Licensed Material available under these terms and conditions.

#### Section 1 – Definitions.

a. **Adapted Material** means material subject to Copyright and Similar Rights that is derived from or based upon the Licensed Material and in which the Licensed Material is translated, altered, arranged, transformed, or otherwise modified in a manner requiring permission under the Copyright and Similar Rights held by the Licensor. For purposes of this Public License, where the Licensed Material is a musical work, performance, or sound recording, Adapted Material is always produced where the Licensed Material is synched in timed relation with a moving image.

b. **Adapter’s License** means the license You apply to Your Copyright and Similar Rights in Your contributions to Adapted Material in accordance with the terms and conditions of this Public License.

c. **Copyright and Similar Rights** means copyright and/or similar rights closely related to copyright including, without limitation, performance, broadcast, sound recording, and Sui Generis Database Rights, without regard to how the rights are labeled or categorized. For purposes of this Public License, the rights specified in Section 2(b)(1)-(2) are not Copyright and Similar Rights.

d. **Effective Technological Measures** means those measures that, in the absence of proper authority, may not be circumvented under laws fulfilling obligations under Article 11 of the WIPO Copyright Treaty adopted on December 20, 1996, and/or similar international agreements.

e. **Exceptions and Limitations** means fair use, fair dealing, and/or any other exception or

limitation to Copyright and Similar Rights that applies to Your use of the Licensed Material.

f. **Licensed Material** means the artistic or literary work, database, or other material to which the Licensor applied this Public License.

g. **Licensed Rights** means the rights granted to You subject to the terms and conditions of this Public License, which are limited to all Copyright and Similar Rights that apply to Your use of the Licensed Material and that the Licensor has authority to license.

h. **Licensor** means the individual(s) or entity(ies) granting rights under this Public License.

i. **Share** means to provide material to the public by any means or process that requires permission under the Licensed Rights, such as reproduction, public display, public performance, distribution, dissemination, communication, or importation, and to make material available to the public including in ways that members of the public may access the material from a place and at a time individually chosen by them.

j. **Sui Generis Database Rights** means rights other than copyright resulting from Directive 96/9/EC of the European Parliament and of the Council of 11 March 1996 on the legal protection of databases, as amended and/or succeeded, as well as other essentially equivalent rights anywhere in the world.

k. **You** means the individual or entity exercising the Licensed Rights under this Public License. **Your** has a corresponding meaning.

## Section 2 – Scope.

a. License grant.

1. Subject to the terms and conditions of this Public License, the Licensor hereby grants You a worldwide, royalty-free, non-sublicensable, non-exclusive, irrevocable license to exercise the Licensed Rights in the Licensed Material to:

A. reproduce and Share the Licensed Material, in whole or in part; and

B. produce, reproduce, and Share Adapted Material.

2. Exceptions and Limitations. For the avoidance of doubt, where Exceptions and Limitations apply to Your use, this Public License does not apply, and You do not need to comply with its terms and conditions.

3. Term. The term of this Public License is specified in Section 6(a).

4. Media and formats; technical modifications allowed. The Licensor authorizes You to exercise the Licensed Rights in all media and formats whether now known or hereafter created, and to make technical modifications necessary to do so. The Licensor waives and/or agrees not to assert any right or authority to forbid You from making technical modifications necessary to exercise the Licensed Rights, including technical modifications necessary to circumvent Effective Technological Measures.

For purposes of this Public License, simply making modifications authorized by this Section 2(a)(4) never produces Adapted Material.

5. Downstream recipients.

A. Offer from the Licensor – Licensed Material. Every recipient of the Licensed Material automatically receives an offer from the Licensor to exercise the Licensed Rights under the terms and conditions of this Public License.

B. No downstream restrictions. You may not offer or impose any additional or different terms or conditions on, or apply any Effective Technological Measures to, the Licensed Material if doing so restricts exercise of the Licensed Rights by any recipient of the Licensed Material.

6. No endorsement. Nothing in this Public License constitutes or may be construed as permission to assert or imply that You are, or that Your use of the Licensed Material is, connected with, or sponsored, endorsed, or granted official status by, the Licensor or others designated to receive attribution as provided in Section 3(a)(1)(A)(i).

b. Other rights.

1. Moral rights, such as the right of integrity, are not licensed under this Public License, nor are publicity, privacy, and/or other similar personality rights; however, to the extent possible, the Licensor waives and/or agrees not to assert any such rights held by the Licensor to the limited extent necessary to allow You to exercise the Licensed Rights, but not otherwise.

2. Patent and trademark rights are not licensed under this Public License.

3. To the extent possible, the Licensor waives any right to collect royalties from You for the exercise of the Licensed Rights, whether directly or through a collecting society under any voluntary or waivable statutory or compulsory licensing scheme. In all other cases the Licensor expressly reserves any right to collect such royalties.

**Section 3 – License Conditions.**

Your exercise of the Licensed Rights is expressly made subject to the following conditions.

a. Attribution.

1. If You Share the Licensed Material (including in modified form), You must:

A. retain the following if it is supplied by the Licensor with the Licensed Material:

i. identification of the creator(s) of the Licensed Material and any others designated to receive attribution, in any reasonable manner requested by the Licensor (including by pseudonym if designated);

ii. a copyright notice;

- iii. a notice that refers to this Public License;
- iv. a notice that refers to the disclaimer of warranties;
- v. a URI or hyperlink to the Licensed Material to the extent reasonably practicable;

B. indicate if You modified the Licensed Material and retain an indication of any previous modifications; and

C. indicate the Licensed Material is licensed under this Public License, and include the text of, or the URI or hyperlink to, this Public License.

2. You may satisfy the conditions in Section 3(a)(1) in any reasonable manner based on the medium, means, and context in which You Share the Licensed Material. For example, it may be reasonable to satisfy the conditions by providing a URI or hyperlink to a resource that includes the required information.

3. If requested by the Licensor, You must remove any of the information required by Section 3(a)(1)(A) to the extent reasonably practicable.

4. If You Share Adapted Material You produce, the Adapter's License You apply must not prevent recipients of the Adapted Material from complying with this Public License.

#### **Section 4 – Sui Generis Database Rights.**

Where the Licensed Rights include Sui Generis Database Rights that apply to Your use of the Licensed Material:

- a. for the avoidance of doubt, Section 2(a)(1) grants You the right to extract, reuse, reproduce, and Share all or a substantial portion of the contents of the database;
- b. if You include all or a substantial portion of the database contents in a database in which You have Sui Generis Database Rights, then the database in which You have Sui Generis Database Rights (but not its individual contents) is Adapted Material; and
- c. You must comply with the conditions in Section 3(a) if You Share all or a substantial portion of the contents of the database.

For the avoidance of doubt, this Section 4 supplements and does not replace Your obligations under this Public License where the Licensed Rights include other Copyright and Similar Rights.

#### **Section 5 – Disclaimer of Warranties and Limitation of Liability.**

a. Unless otherwise separately undertaken by the Licensor, to the extent possible, the Licensor offers the Licensed Material as-is and as-available, and makes no representations or warranties of any kind concerning the Licensed Material, whether express, implied, statutory, or other. This includes, without limitation, warranties of title, merchantability, fitness for a particular purpose, non-infringement, absence of latent or other defects, accuracy, or the presence or absence of errors,

whether or not known or discoverable. Where disclaimers of warranties are not allowed in full or in part, this disclaimer may not apply to You.

b. To the extent possible, in no event will the Licensor be liable to You on any legal theory (including, without limitation, negligence) or otherwise for any direct, special, indirect, incidental, consequential, punitive, exemplary, or other losses, costs, expenses, or damages arising out of this Public License or use of the Licensed Material, even if the Licensor has been advised of the possibility of such losses, costs, expenses, or damages. Where a limitation of liability is not allowed in full or in part, this limitation may not apply to You.

c. The disclaimer of warranties and limitation of liability provided above shall be interpreted in a manner that, to the extent possible, most closely approximates an absolute disclaimer and waiver of all liability.

#### **Section 6 – Term and Termination.**

a. This Public License applies for the term of the Copyright and Similar Rights licensed here. However, if You fail to comply with this Public License, then Your rights under this Public License terminate automatically.

b. Where Your right to use the Licensed Material has terminated under Section 6(a), it reinstates:

1. automatically as of the date the violation is cured, provided it is cured within 30 days of Your discovery of the violation; or

2. upon express reinstatement by the Licensor.

For the avoidance of doubt, this Section 6(b) does not affect any right the Licensor may have to seek remedies for Your violations of this Public License.

c. For the avoidance of doubt, the Licensor may also offer the Licensed Material under separate terms or conditions or stop distributing the Licensed Material at any time; however, doing so will not terminate this Public License.

d. Sections 1, 5, 6, 7, and 8 survive termination of this Public License.

#### **Section 7 – Other Terms and Conditions.**

a. The Licensor shall not be bound by any additional or different terms or conditions communicated by You unless expressly agreed.

b. Any arrangements, understandings, or agreements regarding the Licensed Material not stated herein are separate from and independent of the terms and conditions of this Public License.

#### **Section 8 – Interpretation.**

a. For the avoidance of doubt, this Public License does not, and shall not be interpreted to, reduce, limit, restrict, or impose conditions on any use of the Licensed Material that could lawfully



be made without permission under this Public License.

b. To the extent possible, if any provision of this Public License is deemed unenforceable, it shall be automatically reformed to the minimum extent necessary to make it enforceable. If the provision cannot be reformed, it shall be severed from this Public License without affecting the enforceability of the remaining terms and conditions.

c. No term or condition of this Public License will be waived and no failure to comply consented to unless expressly agreed to by the Licensor.

d. Nothing in this Public License constitutes or may be interpreted as a limitation upon, or waiver of, any privileges and immunities that apply to the Licensor or You, including from the legal processes of any jurisdiction or authority.

Creative Commons is not a party to its public licenses. Notwithstanding, Creative Commons may elect to apply one of its public licenses to material it publishes and in those instances will be considered the “Licensor.” Except for the limited purpose of indicating that material is shared under a Creative Commons public license or as otherwise permitted by the Creative Commons policies published at [creativecommons.org/policies](https://creativecommons.org/policies), Creative Commons does not authorize the use of the trademark “Creative Commons” or any other trademark or logo of Creative Commons without its prior written consent including, without limitation, in connection with any unauthorized modifications to any of its public licenses or any other arrangements, understandings, or agreements concerning use of licensed material. For the avoidance of doubt, this paragraph does not form part of the public licenses.

Creative Commons may be contacted at [creativecommons.org](https://creativecommons.org).



# Appendix E

## References

“Bulletin 1333 3/4-20 HP (.55-15 kW) Adjustable Frequency AC Drive” series D User Manual, Rockwell Automation publication 1333-5.2, Rockwell Automation, Inc., Milwaukee, WI, July 1994.  
Dalziel, Charles F., *Deleterious Effects of Electric Shock*, University of California, Berkeley, CA, October 1961.

“GS1 Series Drives” User Manual, Automationdirect.com, 2002.

*NFPA 70E Standard for Electrical Safety in the Workplace*, 2015 Edition, NFPA, Quincy, MA, 2016.

“PowerFlex 4 Adjustable Frequency AC Drive” User Manual, Rockwell Automation publication 22A-UM001G-EN-E, Rockwell Automation, Inc., Milwaukee, WI, April 2007.

“Wiring and Grounding Guidelines for Pulse Width Modulated (PWM) AC Drives” Installation Instructions, Rockwell Automation publication DRIVES-IN001J-EN-P, Rockwell Automation, Inc., Milwaukee, WI, April 2009.



# Appendix F

## Version history

This is a list showing all significant additions, corrections, and other edits made to this learning module. Each entry is referenced by calendar date in reverse chronological order (newest version first), which appears on the front cover of every learning module for easy reference. Any contributors to this open-source document are listed here as well.

**25 April 2025** – elaborated on the function of line reactors to impede triplen-harmonic currents.

**21 April 2025** – Added another question to the “Currents within a VFD circuit” Conceptual Reasoning problem, asking about output frequency and motor speed.

**19 November 2024** – eliminated references to DC motor drives in the Tutorial, as this was vestigial from the time when this tutorial was part of the *Lessons In Industrial Instrumentation* textbook where the section on VFDs immediately followed a section on DC motor drives.

**14 November 2024** – divided the Introduction chapter into sections, one with recommendations for students, one with a listing of challenging concepts, and one with recommendations for instructors.

**22-23 April 2024** – minor typo corrections.

**29 November 2023** – added field and armature winding labels and connections to image\_0900, and also edited/added some Introduction chapter questions.

**21 June 2023** – added Quantitative Reasoning questions related to computer programming (simulating three-phase circuits).

**28 November 2022** – placed questions at the top of the itemized list in the Introduction chapter prompting students to devise experiments related to the tutorial content.

**9 July 2021** – added a Case Tutorial chapter with a section on demonstrating DC injection braking. Also made minor edits to the index listings for this same topic.

**19-21 April 2021** – minor edits to the Tutorial, including the addition of “clean” and “dirty” sine

waves to the illustrations showing line reactor usage.

**15 April 2021** – significantly edited the Introduction chapter to make it more suitable as a pre-study guide and to provide cues useful to instructors leading “inverted” teaching sessions. Also made some minor edits to the Tutorial.

**18 March 2021** – corrected multiple instances of “volts” that should have been capitalized “Volts”.

**15 March 2021** – added questions.

**12 March 2021** – added photograph of a three-phase line reactor to the Tutorial.

**7 July 2020** – moved the VFD transistor animation into its own L<sup>A</sup>T<sub>E</sub>X file.

**25 May 2020** – corrected an omission in the “VFD configuration example” Conceptual Reasoning problem where I had failed to provide numerical option number values for some of the parameters. Credit goes to Ron Felix for identifying this omission.

**29 January 2020** – added more Foundational Concepts to the list in the Conceptual Reasoning section.

**6 May 2019** – improved question on VFD configuration example.

**3 May 2019** – corrected minor typographical error. Also added an Experiment, on DC injection braking for a small AC motor.

**30 March 2019** – added questions and a project.

**10 March 2019** – completed the Foundational Concepts list.

**2 February 2019** – added Tutorial section on setting motor nameplate parameters.

**1 January 2019** – added a Technical Reference section on electrical safety.

**12 November 2018** – title changed to include “AC”.

**July 2018** – document first created.

# Index

- Acceleration, 22
- Adding quantities to a qualitative problem, 142
- Alternating current, 33
- Angular acceleration, 22
- Annotating diagrams, 141
- Arc, 35
- Arc blast, 39
- Arc flash, 35
- Arc flash boundary, 36
- Arc flash suit, 38
  
- Base parameters, 21
- Bonding, 34
- Boundary, arc flash, 36
- Boundary, limited approach, 36
- Boundary, restricted approach, 36
- Breadboard, solderless, 128, 129
- Breadboard, traditional, 131
- Bridge network, 11
- Busbar, 34
  
- Calorie, 38
- Cardio-Pulmonary Resuscitation, 126
- Carrier frequency, 24
- Checking for exceptions, 142
- Checking your work, 142
- Circuit breaker, 33
- Code, computer, 149
- Conservation of Energy, 15
- CPR, 126
- Current, eddy, 24
  
- Dalziel, Charles, 32, 126
- DC boost, 23, 24
- DC injection braking, AC motor, 8, 14, 15
- De-rating, 24
- Dimensional analysis, 141
  
- DIN rail, 129
- DIP, 128
- Direct current, 33
- Disconnect switch, 34
- Dynamic braking, AC motor, 14, 16
  
- Eddy current, 24
- Edwards, Tim, 150
- Electric shock, 32, 126
- Electrically common points, 34, 127
- Enclosure, electrical, 131
- Equipotential, 34
- Equipotential points, 127, 129
- Experiment, 132
- Experimental guidelines, 133
  
- Filter, 11, 13, 28
- Fourier series, 13
- Fourier, Jean Baptiste Joseph, 13, 27
- Frequency, 33
- Frequency, skip, 26
- Fuse, 33
  
- Graph values to solve a problem, 142
- Greenleaf, Cynthia, 95
  
- Harmonic filtering, 28
- Harmonic frequency, 27
- Hertz, 33
- How to teach with these modules, 144
- Hwang, Andrew D., 151
  
- IC, 128
- Identify given data, 141
- Identify relevant principles, 141
- Incremental inductance, 23
- Inductance, incremental, 23
- Induction motor, 9



- Instructions for projects and experiments, 145
- Intermediate results, 141
- Inverted instruction, 144
- Inverter, 11
- Ionized air, 35
  
- Kinetic energy, 14
- Knuth, Donald, 150
  
- Lampert, Leslie, 150
- Lenz's Law, 15
- Limited approach boundary, 36
- Limiting cases, 142
- Line reactor, 28
- Load, 32
- Lock-out, tag-out, 36
- LOTO, 36
  
- Metacognition, 100
- Moment of inertia, 22
- Moolenaar, Bram, 149
- Motor base parameters, 21
- Motor de-rating, 24
- Motor nameplate parameters, 21
- Murphy, Lynn, 95
  
- Nameplate parameters, 21
- National Fire Protection Association, 36
- Nervous system, 32
- Newton's Second Law of Motion, 22
- NFPA, 36
- NFPA 70E, 36
  
- One-Hand Rule, 35
- Open-source, 149
  
- Plugging, AC motor, 14, 20
- Potential distribution, 129
- Problem-solving: annotate diagrams, 141
- Problem-solving: check for exceptions, 142
- Problem-solving: checking work, 142
- Problem-solving: dimensional analysis, 141
- Problem-solving: graph values, 142
- Problem-solving: identify given data, 141
- Problem-solving: identify relevant principles, 141
- Problem-solving: interpret intermediate results, 141
- Problem-solving: limiting cases, 142
- Problem-solving: qualitative to quantitative, 142
- Problem-solving: quantitative to qualitative, 142
- Problem-solving: reductio ad absurdum, 142
- Problem-solving: simplify the system, 141
- Problem-solving: thought experiment, 133, 141
- Problem-solving: track units of measurement, 141
- Problem-solving: visually represent the system, 141
- Problem-solving: work in reverse, 142
- Project management guidelines, 136
- Pulse-width modulation, 12, 24
- PWM, 12, 24
- PWM frequency, 24
  
- Qualitatively approaching a quantitative problem, 142
  
- Radio frequency interference from motor drive circuits, 13
- Reactor, power line, 28
- Reading Apprenticeship, 95
- Rectifier, 11
- Reductio ad absurdum, 142–144
- Regenerative braking, AC motor, 14, 18
- Restricted approach boundary, 36
- RFI, 13
- Rotating magnetic field, 9, 12
  
- Safety disconnect switch, 34
- Safety, electrical, 126
- Saturation, magnetic, 13, 23
- Schoenbach, Ruth, 95
- Scientific method, 100, 132
- Scope creep, 136
- Shock, electric, 32
- Shunt resistor, 128
- Simplifying a system, 141
- Skip frequency, 26
- Slip speed, 9, 10
- Socrates, 143
- Socratic dialogue, 144
- Solderless breadboard, 128, 129
- Spark, 35
- SPICE, 95, 133

SPICE netlist, 130  
Stallman, Richard, 149  
Stator, 9, 12  
Subpanel, 131  
Surface mount, 129  
Switch, disconnect, 34  
Synchronous motor, 9  
Synchronous speed, 9

Terminal block, 127–131  
Thought experiment, 133, 141  
Torque, 9, 13, 22  
Torque, constant, 23  
Torque, variable, 23  
Torvalds, Linus, 149

Units of measurement, 141

V/F ratio, 13, 23  
V/Hz ratio, 13, 23  
Variable-frequency drive, 10  
VFD, 10  
Visualizing a system, 141  
Volt-second product, 23  
Voltage-to-frequency ratio, 13, 23

Wiring sequence, 130  
Work in reverse to solve a problem, 142  
WYSIWYG, 149, 150