

MODULAR ELECTRONICS LEARNING (MODEL) PROJECT



VOLTAGE, CURRENT, RESISTANCE, AND BASIC CIRCUIT CONCEPTS

© 2016-2025 BY TONY R. KUPHALDT – UNDER THE TERMS AND CONDITIONS OF THE
CREATIVE COMMONS ATTRIBUTION 4.0 INTERNATIONAL PUBLIC LICENSE

LAST UPDATE = 2 MAY 2025

This is a copyrighted work, but licensed under the Creative Commons Attribution 4.0 International Public License. A copy of this license is found in the last Appendix of this document. Alternatively, you may visit <http://creativecommons.org/licenses/by/4.0/> or send a letter to Creative Commons: 171 Second Street, Suite 300, San Francisco, California, 94105, USA. The terms and conditions of this license allow for free copying, distribution, and/or modification of all licensed works by the general public.

Contents

1	Introduction	3
1.1	Recommendations for students	3
1.2	Challenging concepts related to voltage, current, and resistance	5
1.3	Recommendations for instructors	7
2	Case Tutorial	9
2.1	Example: money analogy for voltage	10
2.2	Example: Battery, lamp, jumper wires, and meters	13
2.3	Example: A simple (working) circuit	14
2.4	Example: An open circuit	15
2.5	Example: A shorted circuit	17
2.6	Example: potential in open and shorted circuits	18
2.7	Example: A continuity tester	25
2.8	Occam’s Razor as a general diagnostic principle	26
3	Simplified Tutorial	31
4	Full Tutorial	39
4.1	Potential energy	40
4.2	Conservation laws	41
4.3	Electric potential and voltage	42
4.4	Electric resistance, current, and circuits	45
4.5	Concept review	47
4.6	Energy transfer in circuits	49
4.7	Causes of voltage, current, and resistance	52
4.8	Opens and shorts	53
4.9	Switches	56
5	Historical References	57
5.1	Benjamin Franklin on the nature of electricity	58
5.2	James Clerk Maxwell on charge, potential, and electrical energy	62
5.3	James Clerk Maxwell on the nature of electric potential	63
5.4	John Ambrose Fleming on the nature of electric potential	64
5.5	James Prescott Joule on the conservation of energy	66

CONTENTS	1
6 Derivations and Technical References	75
6.1 Fluid pressure as an analogue of voltage	76
6.2 Metric prefixes	80
7 Questions	85
7.1 Conceptual reasoning	89
7.1.1 Reading outline and reflections	90
7.1.2 Foundational concepts	91
7.1.3 Irrigation water	93
7.1.4 Applying foundational concepts to a two-lamp circuit	94
7.1.5 A three-lamp circuit	95
7.1.6 Voltage with no current (and vice-versa)	96
7.1.7 Lightning	97
7.1.8 A shocking experience	98
7.1.9 Polarities in a multi-lamp circuit	99
7.1.10 Electrically common versus distinct terminals	100
7.2 Diagnostic reasoning	101
7.2.1 Properties of connected points	102
7.2.2 Effects of breaks in a motor circuit	103
7.2.3 Faults in a crude battery/lamp circuit	105
7.2.4 Faults in a terminal block battery/lamp circuit	106
8 Projects and Experiments	109
8.1 Recommended practices	109
8.1.1 Safety first!	110
8.1.2 Other helpful tips	112
8.1.3 Terminal blocks for circuit construction	113
8.1.4 Conducting experiments	116
8.1.5 Constructing projects	120
8.2 Experiment: measuring battery voltages	121
8.3 Experiment: measuring resistances	123
8.4 Experiment: battery and lamp circuit	125
8.5 Experiment: variable resistance circuit	126
A Problem-Solving Strategies	129
B Instructional philosophy	131
C Tools used	137
D Creative Commons License	141
E References	149
F Version history	151
Index	154

Chapter 1

Introduction

1.1 Recommendations for students

This module explores the most fundamental principles of electric circuits, including the quantities of voltage, current, and resistance. It is critically important to learn this well, because many of the struggles faced by students of electricity and electronics are traceable to misunderstandings of these very principles.

When first learning anything new, it is extremely helpful to challenge yourself to express what you have learned into your own words, using your own examples, and to discover how these new ideas connect to ideas previously learned. You can do this by writing, by speaking, and also by direct application (by doing). Then, share your thoughts and actions with others to gain their perspective. If you are a student in a formal educational environment, bringing this level of engagement to the conversation will help you (as well as your fellow students) tremendously. You will find this not only helps you remember, but it also gives you greater depth of understanding.

Important concepts include **energy** (both potential and kinetic) and its universal **conservation**, electrical **polarity**, the action of **fields** upon matter, the motion of **electric charges** through matter, **voltage**, **current**, **hydraulic head**, **resistance**, **opens**, **shorts**, **switches**, and electrical **point relations** (equipotential, common, distinct, isolated).

The Tutorials make ample use of analogies to help explain the action of electrical circuits. No analogy is ever perfectly accurate, and therefore these analogies should not be taken literally, but they are still helpful in conveying the fundamental principles. Each of these analogies involves the transfer of energy (or something akin to energy), which is their relatable principle to electric circuits.

Here are some good questions to ask of yourself while studying this subject:

- How might an experiment be designed and conducted to test the effects of “opens” and “shorted” circuits? What hypotheses (i.e. predictions) might you pose for that experiment, and what result(s) would either support or disprove those hypotheses?
- What are some practical applications of electricity and electric circuits?

- What is energy, and what are some of its different forms?
- What is the effect of a field upon matter?
- What does it mean that energy, matter, and electric charge are all *conserved* quantities?
- How does potential energy relate to displacement and force?
- What is voltage, and how does it relate to energy?
- What is current, and how does it relate to the transfer of energy in a circuit?
- What is resistance, and how does it relate to the transfer of energy in a circuit?
- What is the guaranteed effect of an *open* in an electric circuit?
- Is the effect of an open localized to one part of a circuit, or does it affect the entire circuit?
- What is the guaranteed effect of a *short* in an electric circuit?
- Is the effect of a short localized to one part of a circuit, or does it affect the entire circuit?
- Where is energy being transferred in an electric circuit? Where does it originate and where does it move to?
- What do the “+” and “−” symbols mean when annotating a voltage in a circuit?
- What are a few different analogies for understanding voltage?
- Why is it nonsense to speak of resistance at a single point in a circuit?
- What are some common sources of voltage?
- What are some common examples of resistance?
- What is a “limiting case” and how may they be helpful to us in solving certain problems?

To maximize your learning when reading from a text, you should write your own journal recording your interpretation of the text as well as any questions or points of confusion you may have after reading it. You will find practical suggestions for how to do this in the “Reading outline and reflections” subsection of the Conceptual reasoning section of the *Questions* chapter. Additionally, the “Foundational concepts” subsection in that same chapter gives a list of important principles explained and referenced in this learning module. A good self-check of your reading comprehension is to see if you are able to define each of those listed concepts.

1.2 Challenging concepts related to voltage, current, and resistance

The following list cites concepts related to this module's topic that are easily misunderstood, along with suggestions for properly understanding them:

- **Force versus Energy** – while these two concepts are related to each other, they are not synonymous. Energy is anything having the ability to set matter into motion, and while transfers of energy always involve forces at some level, they are not the same thing. Consider lifting a weight upwards against the gravitational pull of Earth: the higher you lift this weight, the more potential energy it will have; however, the amount of force you must exert to hoist this weight is constant no matter how high you lift it!
- **Shorts versus Opens** – these are two distinctly different types of electrical conditions, and are not generic labels for *any* problem that might occur in a circuit¹. Each of these conditions is characterized by a prohibition of some electrical measure: shorts prevent voltage from existing between the two points that are shorted together, and opens prevent current from passing through the conductors that used to be joined. A very common misconception is that shorts ensure current and opens ensure voltage, but it is more accurate to say that *shorts prohibit voltage* and *opens prohibit current*.
- **Charge carrier motion in a simple circuit** – a common misunderstanding is to think of electricity in a circuit as like a fluid that must first fill up empty pipes (wires), which in turn would mean that flow (current) starts at the positive end of the source and progresses throughout the whole circuit until it finally reaches the source's negative end. In fact, electrical conductors are by their very nature completely full of mobile charge carriers and in this way are definitely *not* like empty pipes that first need to be filled from a liquid source. Wires, like *pre-filled pipes*, naturally possess an abundance of free charge carriers, so that motion anywhere results in motion everywhere throughout the loop. This explains why a break anywhere in a simple circuit instantly halts current everywhere. It also helps explain why voltage is divided amongst series-connected loads instead of the load closest to the source's positive terminal experiencing the entire source voltage.
- **Voltage polarity symbols** – the “+” and “-” symbols used to denote voltages in circuits only have meaning as *pairs* and do not mean anything on their own.
- **Voltage as a relative quantity** – this is arguably one of the most difficult concepts students first encounter when studying electricity: understanding that voltage is a *difference* in energy levels between two locations, and not something that can exist at any single point. In this respect, voltage is similar to *distance* which is always something existing *between* two specified points.
- **Voltage versus Current** – these are two completely distinct things, each capable of existing without the other. *Voltage* is the amount of potential energy lost or gained by electric charge carriers as they move from one place to another, whereas *current* is the actual motion of electric charge carriers.

¹It is common for new students of electricity to assume, for example, that “short” means any type of fault whatsoever!

- **Energy flow versus Charge flow** – a circuit consists of a continuous path through which electric charge carriers may flow (i.e. a path for electric current), while energy in a circuit generally moves from one device (a source) to another (a load).

The *Case Tutorial* chapter contains examples of elementary circuits designed to illuminate certain important concepts and also demonstrate good technique. In particular, the “Example: potential in open and shorted circuits” Case Tutorial section has proven extremely helpful for students’ understanding of what voltage is, which is perhaps the most confusing foundational concept related to electricity. The *Historical References* chapter also contains many useful sections explaining these same concepts from different perspectives over time, including Benjamin Franklin’s explanation of his famous kite experiment and his thoughts on “electric matter”, James Clerk Maxwell’s thoughts on electrical energy and electrical potential, John Ambrose Fleming’s very clear presentation of electrical potential, and selections from a lecture given by James Prescott Joule on energy and its conservation.

This module introduces the foundational concepts of electricity: *voltage*, *current*, and *resistance*. Current is a relatively easy concept to understand, being the average flow of electric charge carriers through any substance. Resistance is likewise easy to grasp, being any opposition to electric current resulting in energy dissipation. Voltage, however, is a challenging concept². Closely related to the concept of potential energy, voltage is always a relative quantity existing between two points. It is practically meaningless to speak of voltage being at a single location in any circuit, and it is utter nonsense to speak of voltage “flowing” from one place to another. Current is proper term for the flow of electric charges, and voltage is an expression of how much energy those charges gain or lose if moved from *one location* to *another*.

²Voltage is often referred to as *electromotive force*, or *EMF*, but even this terminology is misleading. Referring to voltage as a “force” because it causes charges to move is analogous to calling energy a “force” because it causes matter to move. To be sure, force is related to energy, but the two concepts are not the same.

1.3 Recommendations for instructors

This section lists realistic student learning outcomes supported by the content of the module as well as suggested means of assessing (measuring) student learning. The outcomes state what learners should be able to do, and the assessments are specific challenges to prove students have learned.

- **Outcome** – Demonstrate effective technical reading and writing
 - Assessment – Students present their outlines of this module’s instructional chapters (e.g. Case Tutorial, Tutorial, Historical References, etc.) ideally as an entry to a larger Journal document chronicling their learning. These outlines should exhibit good-faith effort at summarizing major concepts explained in the text.

- **Outcome** – Predict relative electrical potentials in circuits
 - Assessment – Explain how and why the various colorings used in the “Example: potential in open and shorted circuits” Case Tutorial section were determined based on circuit status (unfaulted, open, shorted).
 - Assessment – Identify relative electrical potentials in a random circuit given by the instructor or chosen from the tutorial, explaining the reasoning behind those determinations.

- **Outcome** – Apply foundational concepts to a given circuit
 - Assessment – Properly identify true/false statements about a given circuit and defend each answer by appeal to the correct foundational concept(s); e.g. pose problems in the form of the “Applying foundational concepts to a two-lamp circuit” Conceptual Reasoning question.
 - Assessment – Properly identify both voltage and current as they would be found within circuits either provided by the instructor or chosen from the tutorial, clearly differentiating between these two concepts.
 - Assessment – Properly identify points within circuits either provided by the instructor or chosen from the tutorial between which we would expect to measure significant voltage, as well as points between which we would *not* expect to measure any significant voltage
 - Assessment – Identify the effects of “opens” and “shorts” as they appear in circuits either provided by the instructor or chosen from the tutorial.
 - Assessment – Identify the flow of energy into and out of circuits either provided by the instructor or chosen from the tutorial.

- **Outcome** – Independent research
 - Assessment – Read and summarize in your own words what early electrical experimenters and technologists wrote about concepts such as voltage, current, and resistance. Recommended readings include *A Treatise on Electricity and Magnetism* (1904 book) by James Clerk Maxwell, *Electric Lamps and Electric Lighting* (1894 book) by John Ambrose Fleming³, *On Matter, Living Force, and Heat* (1847 lecture) by James Prescott Joule.

³Fleming was a very productive and very clear writer, whose works are highly recommended for serious students of electricity.

Chapter 2

Case Tutorial

The idea behind a *Case Tutorial* is to explore new concepts by way of example. In this chapter you will read less presentation of theory compared to other Tutorial chapters, but by close observation and comparison of the given examples be able to discern patterns and principles much the same way as a scientific experimenter. Hopefully you will find these cases illuminating, and a good supplement to text-based tutorials.

These examples also serve well as challenges following your reading of the other Tutorial(s) in this module – can you explain *why* the circuits behave as they do?

2.1 Example: money analogy for voltage

Electrical *voltage* is a widely misunderstood concept. This example shows a helpful analogy for understanding voltage in terms of *energy* difference for electrical charge carriers in a circuit.

The following diagram shows the path of a person visiting a bank to withdraw some money, then spending that money at two different locations, returning to their starting point with the exact same amount of money in their pocket as they started with. The difference of money between two different locations is equivalent to “voltage” in an electric circuit: a difference of potential energy possessed by an electric charge at two different locations. The person’s travels between these locations is equivalent to “current” in an electric circuit: the motion of electric charge carriers in a loop.

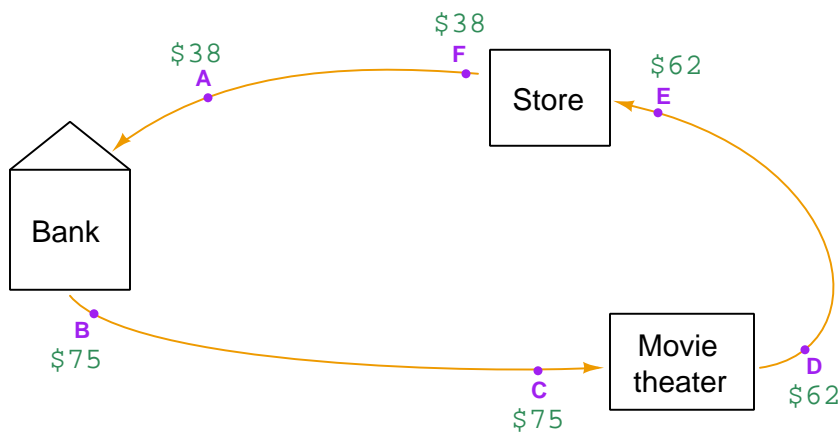

Our hypothetical person begins at point A with \$38 in their pocket, withdraws \$37 from the bank to have \$75 at point B, then spends \$13 at the movie theater and \$24 at the store. Arriving back at point A with the same \$38 in their pocket they started with, it is possible for them to repeat this loop indefinitely with no net accumulation or loss of money, simply acting as a courier of cash from the bank to these two places of purchase.

Note how the actual amount of money at point A is irrelevant – it’s just the amount *gained* or *lost* between points that matters so long as the person repeats the loop with the same amount of (starting) money every time. Likewise, voltage is simply the relative gain or loss of electrical potential energy (per unit charge) between any two locations rather than being any sort of absolute measure of potential energy.

This analogy also helps to illustrate *conservation laws*, specifically the Conservation of Energy and the Conservation of Electric Charge. Here we could call them the *Conservation of Money* and *Conservation of People*: money does not magically appear or disappear, but must always be accounted; likewise the person never vanishes and neither do new people appear from nowhere.

If we imagine an instrument called a “money meter” built to compare the amount of cash carried by the person between any two points, we see how its indication will express a relative gain or loss between those:

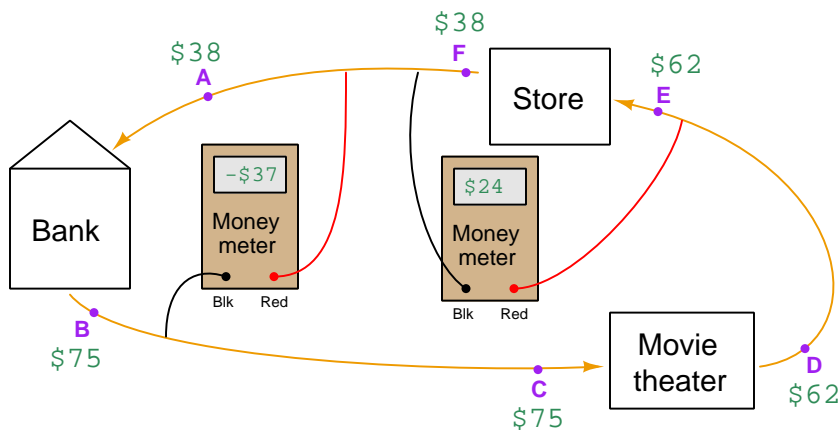

This is what a *voltmeter* does: it shows you how much more (or less) potential energy each charge carrier possesses at its red test lead compared to its black. The red lead is the “measurement” and the black lead is the “reference” by which the measurement point is judged. Another way of looking at it is to think of the meter showing you the mathematical difference between the two (i.e. red potential minus black potential). With the money analogy the “money meter” shows either a *debit* (money spent) or a *credit* (money earned) by each person passing between the two points.

If we compare the *direction* of this person’s travels (counter-clockwise) to the gain or loss of money at each step, we may determine whether each establishment functions as a *source* or as a *load*. The bank functions as a source of money to the person, since the person exits the bank with more money than they had when they entered. Both the movie theater and the store function as loads, since in each case the person exits with less money than they had when they entered. A source gives money to the person, while a load takes money away from the person. Similarly, an electrical source gives energy to the passing charge carriers, while an electrical load takes energy away from the charge carriers as they pass through.

If the “money meter” is connected between points A and F, or between points B and C, or between points D and E, it will register zero because no money was collected or spent by the person between those locations. This is electrically analogous to points located along an unbroken wire, which we call *electrically common* points. Such points happen to be *equipotential* because the negligible resistance of the wire forces electric charges along that wire to all equalize in potential energy.

Summarizing key concepts in the “money analog”:

- *Voltage* in an electric circuit is the difference in potential energy possessed by electric charge carriers at one location versus at another location, analogous to the difference in money possessed by each person between two different points in their journey
- *Current* in an electric circuit is the rate at which charge carriers drift through a conductor, analogous to the number of persons moving by any particular point per unit time
- *Energy is conserved*, which means it cannot be created or destroyed, just as the total amount of money in the analogy is constant but merely moves from the bank to the store and theater over time
- *Electric charges are conserved*, which means they also cannot be created or destroyed, just as the total number of people moving about in the analogy is constant
- *Electrically common points* in an electric circuit all have the same potential because no energy is lost or gained as electric charges move from one of these locations to another, just as the people in the analogy don't lose or gain any money while traveling *between* the bank, theater, and store
- *Resistance* is where charge carriers lose energy traveling from one location to another in an electric circuit, just as persons in the analogy are depleted of some of their money as they spend it
- Electric charges *circulate* in an electric circuit just as people trace a circular path from bank to theater and store and back to the bank again, but energy *moves in one direction* from source(s) to load(s) just as money moves in one direction from the bank to the theater and store

2.2 Example: Battery, lamp, jumper wires, and meters

Here, a large 12 Volt battery and 12 Volt-rated lamp are provided for experimentation, along with “jumper” wires consisting of plastic-clad stranded copper conductors terminated with spring-loaded “alligator” clip jaws at either end. A simple voltmeter with red- and black-colored test leads stands ready to measure voltage, while a simple ammeter with a magnetic sensor stands ready to measure electrical current:

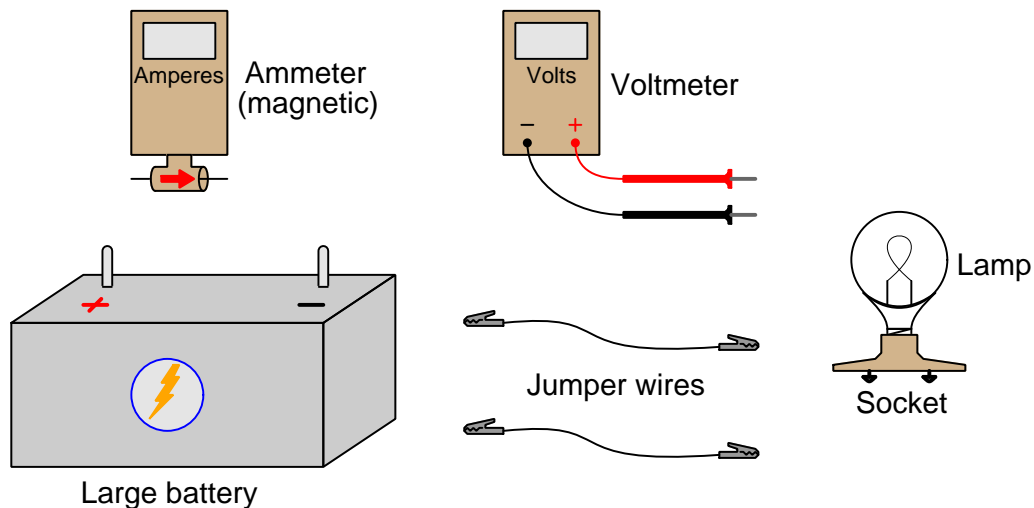

Current is defined as the motion of incredibly small “electric charge carriers” inside of electrically conductive materials such as copper metal, the *Ampere* being a unit of measurement for how many of these charge carriers pass by every second. The ammeter shown here senses electric current by the magnetic field produced around any current-carrying conductor.

Voltage is defined as the difference in energy per electric charge carrier between two locations, and is sensed by the voltmeter using two copper-wire *test leads* that are touched to the two locations of interest.

For every example shown in this Case Tutorial, we will connect the meters in such a way that they register mathematically positive (e.g. +12 Volts, rather than -12 Volts). For “DC” (Direct Current) electric circuits where electric charge carriers move in a consistent direction, reversing the orientation of a voltmeter’s test leads or a magnetic ammeter’s sensor will result in a measurement of the opposite mathematical sign.

A DC voltmeter will register a mathematically positive value when its red test lead (“+”) contacts a point whose electric charge carriers are at a higher energy level than the point contacted by the black test lead (“-”). A DC magnetic ammeter will register a mathematically positive value when current flows in the direction shown by the sensor’s arrow marking.

2.3 Example: A simple (working) circuit

Connecting the two metal terminals of the battery with the two metal terminals of the lamp socket using “jumper wires” (plastic-covered copper wires terminated by alligator clips) results in the lamp energizing:

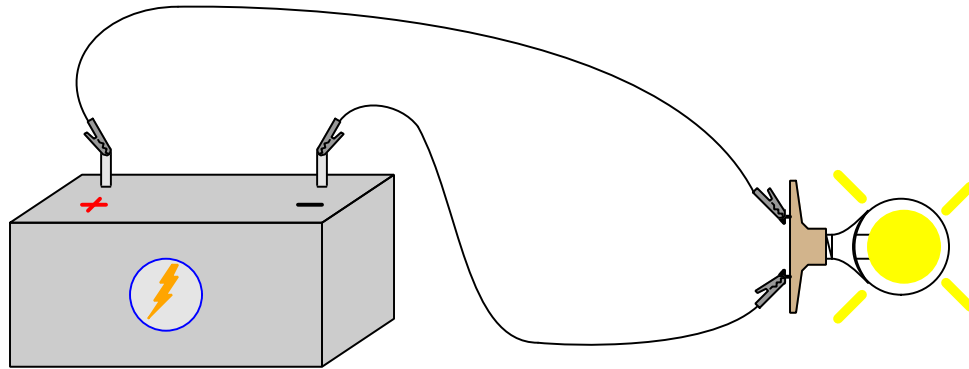

Inserting meters into this circuit shows us voltage between the lamp’s terminals and current through the wires:

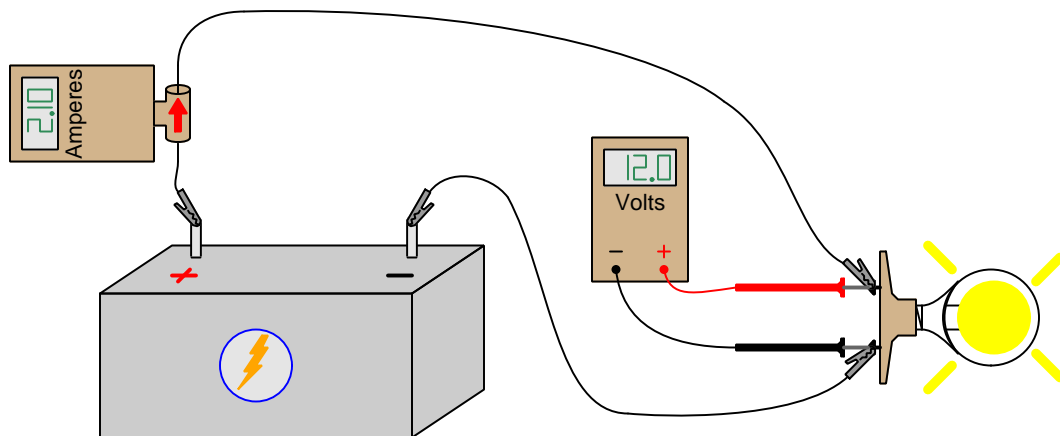

The voltmeter also registers 12.0 Volts when connected to the battery’s terminals (red to +, black to -), but registers zero when connected to opposite ends of either jumper wire. In other words, there is voltage across the lamp and voltage across the battery, but no voltage across either wire.

The ammeter also registers the same 2.1 Amperes of current through the other jumper wire, but with the arrow pointing *toward* the battery rather than *away* from it.

2.4 Example: An open circuit

Breaking metal-to-metal contact between any alligator clip and its corresponding terminal makes the lamp immediately de-energize:

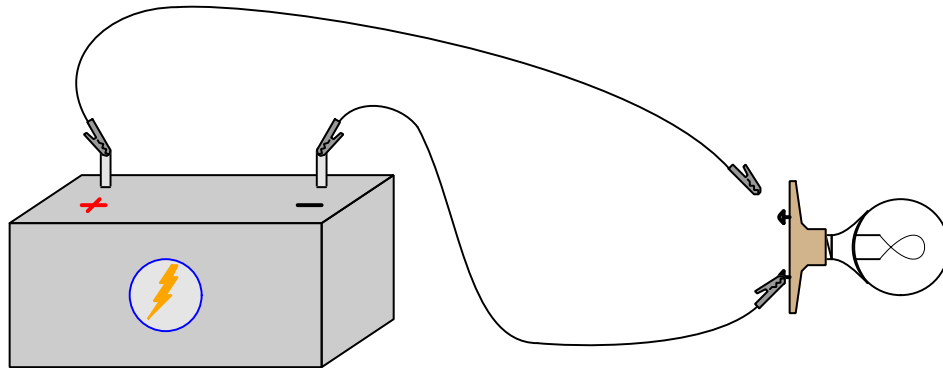

It doesn't matter which connection is broken, or how many connections are broken. *Any* interruption of the circuit (i.e. the closed path) between the battery's two terminals and the lamp's two terminals results in de-energization and no light. The only configuration resulting in the lamp's energization is a wire connecting the positive (+) terminal of the battery with one terminal of the lamp, and another wire connecting the negative (-) terminal of the battery with the other terminal of the lamp. This condition is called an *open circuit*.

Voltage measured across the lamp's terminals is zero, as is current through either jumper wire:

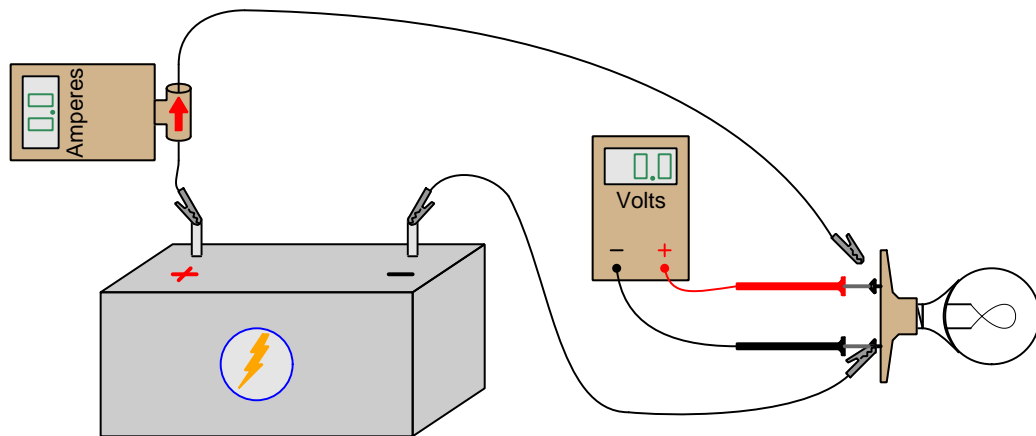

The voltmeter still registers 12.0 Volts when connected across the battery's terminals, just as in the functioning lamp circuit. Voltage across each jumper wire (i.e. voltmeter connected to opposite ends of the same wire) is still zero as before. The ammeter registers zero current regardless of the break's location.

When the voltmeter test leads are made to touch the two disconnected points in a single-break circuit (i.e. the loose alligator clip and the component terminal it used to touch), the voltmeter registers full battery voltage (12.0 Volts):

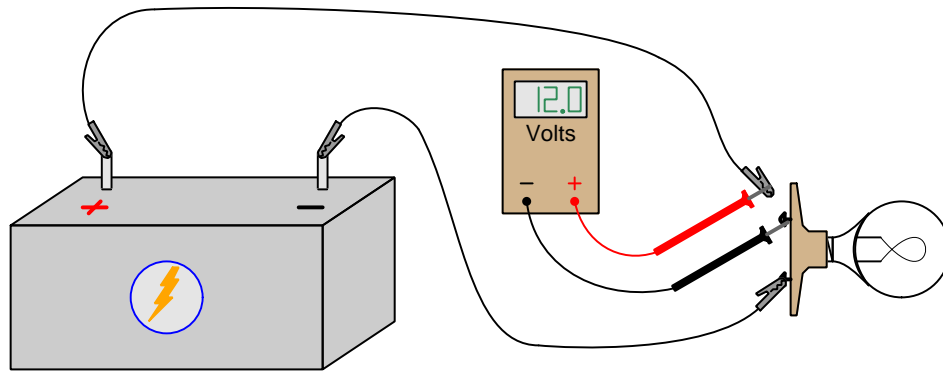

2.5 Example: A shorted circuit

Connecting a third jumper wire into the circuit results in disaster:

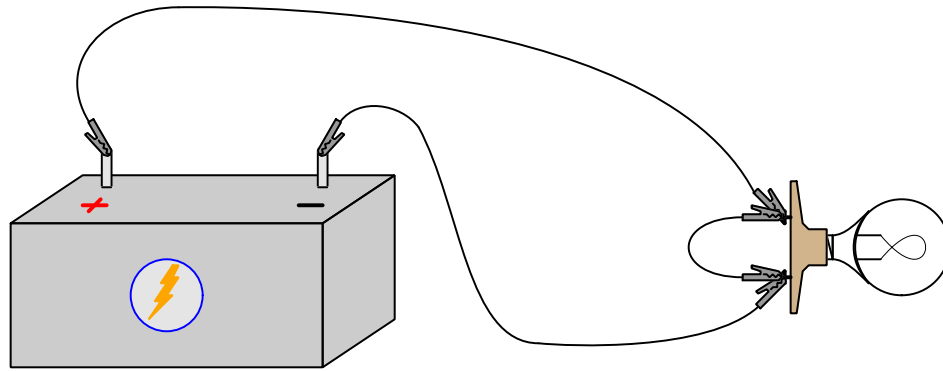

As soon as the last alligator clip of this third wire touches its lamp terminal, three things immediately happen:

- A violent electrical spark appears at the final point of contact
- The lamp de-energizes
- All three jumper wires become hot, and their plastic insulation begins to smoke and melt

Additionally, the battery begins to become warm. If this condition persists, the battery may become damaged.

This condition is called a *short-circuit*, where a direct metal-wire path exists between the two terminals of an electrical energy source (e.g. a battery). Short circuits are usually destructive, and are generally to be avoided!

2.6 Example: potential in open and shorted circuits

Here we will explore the concept of *potential* in both electric and hydraulic circuits. The following illustrations will be used, each circuit containing one *source* tasked with boosting the potential energy of the flow and two *loads* where that flow releases energy to do useful work:

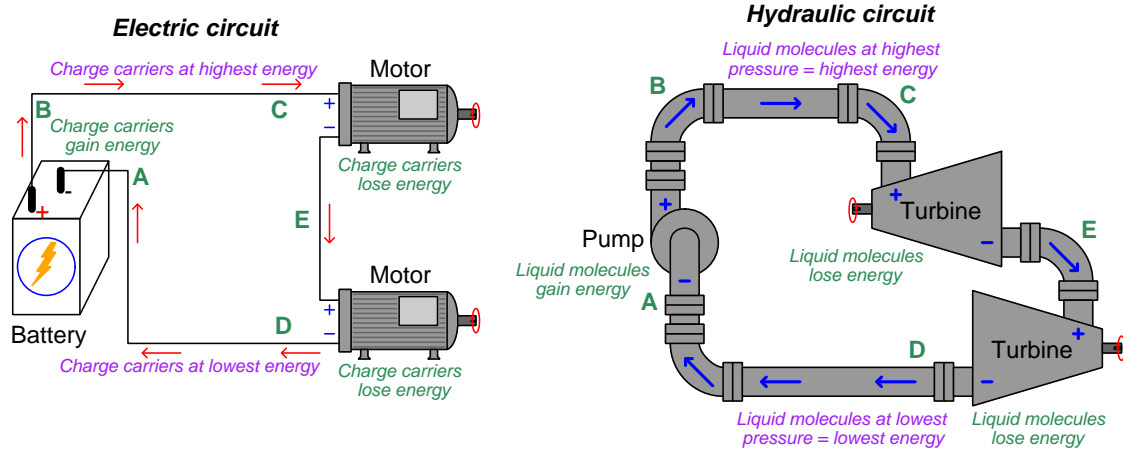

“Potential” may be thought of as *specific potential energy*, or the amount of potential energy possessed by a certain quantity of mobile fluid particles. In the case of electricity, electric potential is the number of Joules of potential energy carried by one Coulomb (6.2415×10^{18}) of charge carriers. In the case of hydraulic systems, fluid potential is better known as *pressure* and is the number of Joules of potential energy carried by one cubic meter of the fluid.

Differences of potential may be precisely quantified in any circuit, be it *voltage* for electric circuits or *pressure differential* for hydraulic circuits. The “+” and “-” symbol pairs shown in each illustration represent the high-potential and low-potential sides of each difference. Each component’s identity as either a source or a load is clear to see from a comparison of these “+” and “-” polarity marks in conjunction with the direction of flow. Note how each source takes in flow on the low-potential (-) side and outputs flow on the high-potential (+) side as it boosts the potential of the flowstream, while each load does just the opposite as energy is released by the flow.

Here we show the circuit illustrations with higher and lower potentials color-coded¹: red to signify high potential, orange to signify medium potential, and blue to signify low potential. Applying these colors to the original illustrations:

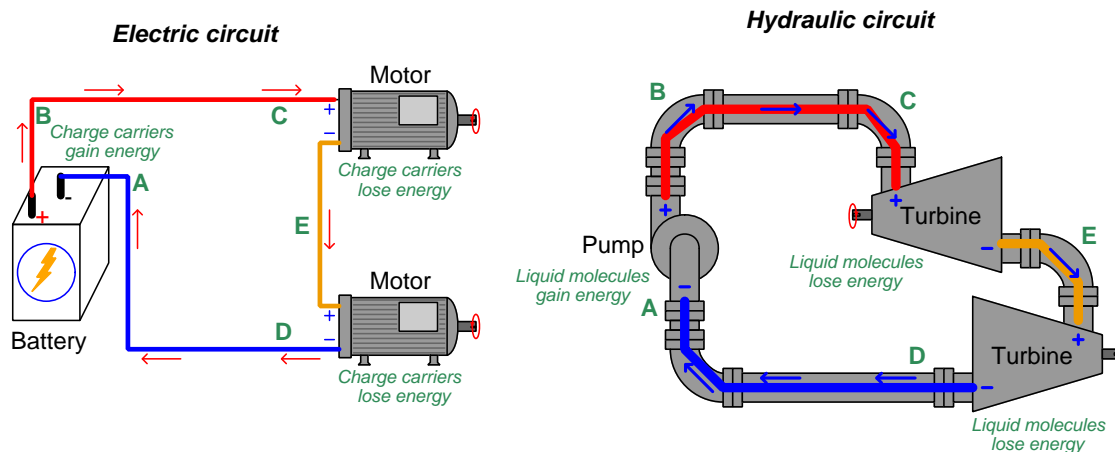

These color-coded potentials are all qualitative in nature. It is really impossible to precisely specify potential at any single location in a circuit, whether electrical or hydraulic, because potential energy depends on *two* conditions: a starting condition and an ending condition. We cannot say with any certainty how much energy is *potentially* released by any given fluid unless we know for certain what its end-state will be. This is why voltage in an electrical circuit is always relative between two points: an expression of how much potential was either gained or lost by charge carriers passing from one location to another. In a similar sense, hydraulic liquid pressure is also relative between two points: even a simple pressure gauge registering liquid pressure inside of a pipe is actually sensing the *difference* in pressure between the fluid within the pipe versus the atmospheric (air) pressure surrounding the pressure gauge. Thus, in both circuits the color-coding merely represents “greater” and “lesser” potential on a relative scale rather than absolute values of potential.

¹These same colors are often used to signify relative liquid pressures in hydraulic system illustrations.

Now we will place an “open” (i.e. a blockage to flow) on the upper portion of each circuit:

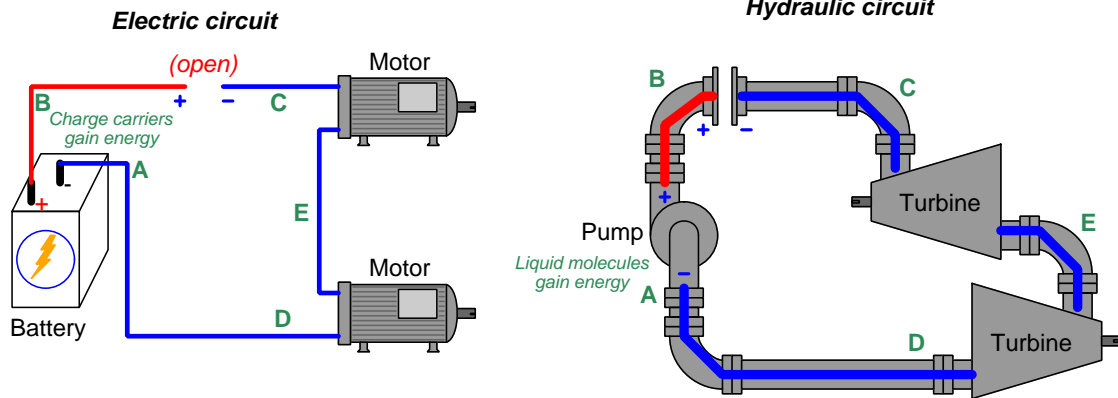

Note how the only portion with high potential lies between the “+” side of the source and the “opened” pathway. All other portions of each circuit immediately equalize in potential to be the same (low). No longer will a difference of potential develop across each load, since the flow ceases everywhere as a result of the “open”, but a potential difference does exist across the “open”.

Next we will place an “open” on the lower portion of each circuit:

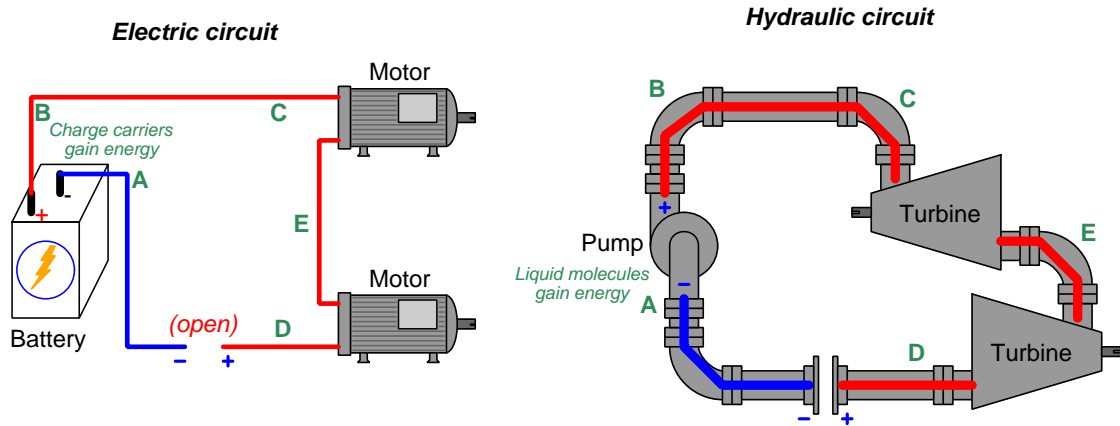

Note how the only portion with low potential lies between the “-” side of the source and the “opened” pathway. All other portions of each circuit immediately equalize in potential to be the same (high). Each load experiences zero difference of potential across it, since the flow ceases everywhere as a result of the “open”, but a potential difference does exist across the “open”.

Our last “open” will be placed between the two loads in each circuit:

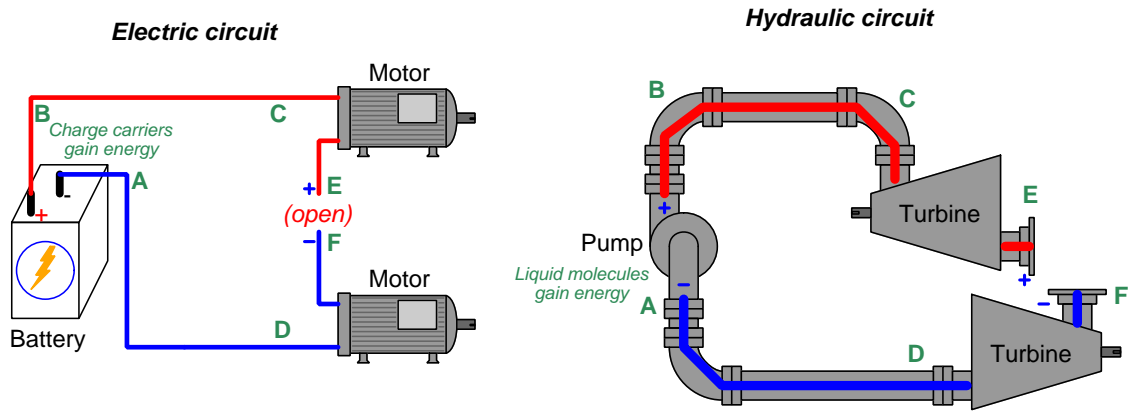

The “open” placed between the two loads creates a new distinct point which we label as **F**. Note how the lower load and its connection to the source maintains a low potential throughout, while the upper load and its connection to the source is at high potential throughout. Neither load has a difference of potential across it, but there is a difference of potential across the “open” in each circuit. The lack of flow, however, means no work is being done.

“Shorting” past loads in a circuit also affects the distribution of potential. Here we see the upper load shorted in each circuit:

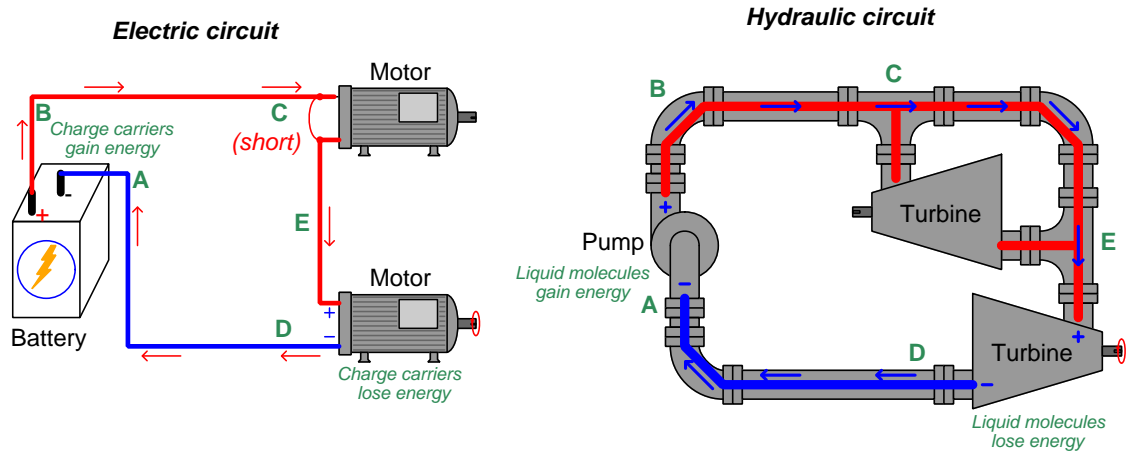

Making both ends of the upper load “common” to each other ensures equipotentiality, robbing the upper loads of any potential difference. This means the flow will not lose any energy going past the shorted load, and instead will deliver all its energy to the lower load which still provides resistance to the flow and is therefore able to extract energy from the flow.

Now we will short past the lower load in each circuit to see the effects:

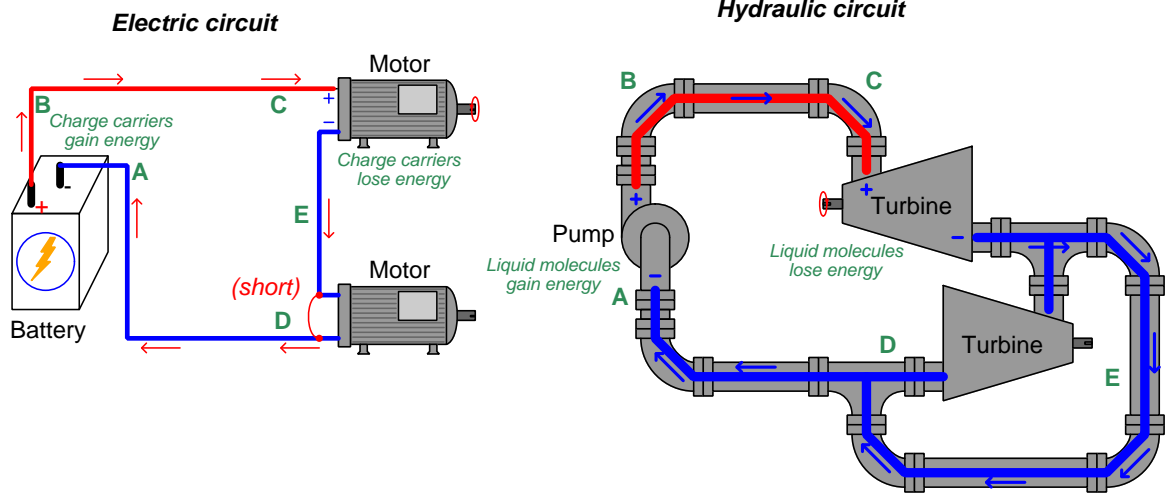

Making both ends of the lower load “common” to each other ensures equipotentiality, robbing the lower loads of any potential difference. This means the flow will not lose any energy going past the shorted load, and instead will deliver all its energy to the upper load which still provides resistance to the flow and is therefore able to extract energy from the flow.

2.7 Example: A continuity tester

A simple battery-and-lamp circuit may be used as an instrument for testing the electrical continuity of different substances or devices:

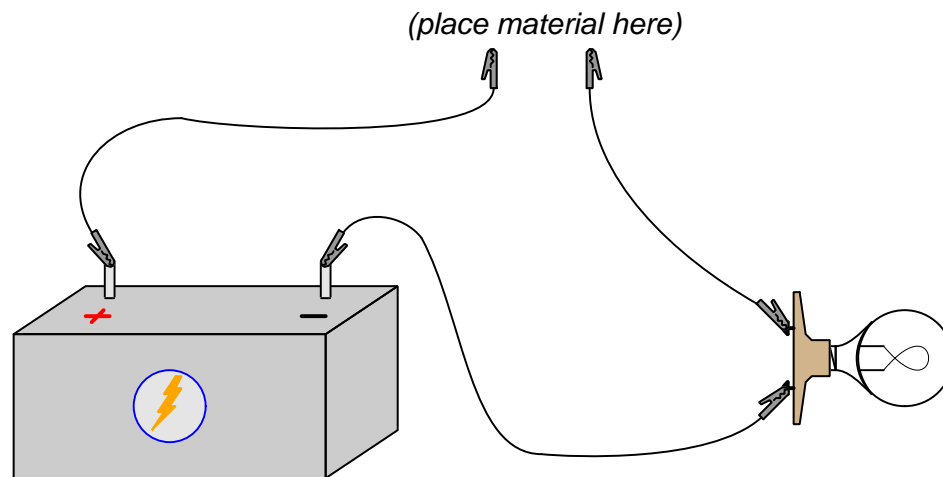

If a conductive substance is placed between the two open-ended alligator clips, the lamp will energize because that substance provides a low-resistance pathway for electric charge carriers. If a non-conductive substance is placed between the two clips, the lamp will be de-energized and full battery voltage will be dropped across those clips.

2.8 Occam's Razor as a general diagnostic principle

Sir William of Ockham was an English theologian who lived from 1287 to 1347, and whose name is attached (albeit often with different spellings) to a logical principle supremely useful in technical diagnostic work. Simply put, Occam's Razor states that the likeliest explanation for anything is that which employs the fewest assumptions. The word "razor" simply refers to the mental task of eliminating (i.e. shaving away) unnecessary assumptions until we are left with the most probable explanation for something.

Let's consider a common example everyone can surely relate to: misplacing something. Suppose you are leaving your home to go to work, school, or some other destination, and on your way out the door you realize you are missing some important item such as your keys, your wallet or purse, your hat, etc. Realizing this, you return inside your home to find this item, but to your dismay it is not where you usually leave it. Why is this item missing, and where may you find it? Multiple explanations are possible, just a few of them listed here:

1. You were distracted while previously handling this item, and set it somewhere you usually don't
2. Someone who lives with you borrowed this item
3. A thief broke into your house and stole this item
4. An interstellar species traveled light-years across space and decided to teleport your item to their spacecraft for research before returning to their home planet

How many independent assumptions are necessary for each of these explanations? For the first (distraction), there is only one assumption and that is your prior distraction. For the second there is the assumption that a house-mate would fail to notify you of their borrowing the item. For the third one must assume that the thief left no clue as to their entry and apparently were only motivated to steal this one item and none else you would have noticed. For the fourth rests on a host of assumptions: the existence of intelligent creatures far from Earth, their ability to travel here and scoop up your item unnoticed, their motive for doing so, etc., etc.

If you found yourself in the position of lacking this item on your way out the door of your home, you may very likely consider the first two explanations as possible, but not give any serious consideration to the third or fourth because they are so far-fetched. What makes them far-fetched is not their assured impossibility, but rather their *improbability* based on the number of assumptions necessary. You *might* be inclined to entertain explanation #3, but only after a thorough search of your house and inquiries of your house-mates failed to reveal the item's whereabouts. No one would seriously consider explanation #4. Of the first two explanations, the first is probably more likely than the second unless you happen to live with careless and inconsiderate people who would fail to let you know they needed to borrow this item from you.

Now let's consider how we might apply the principle of fewest (or least-unlikely) assumptions to electrical troubleshooting. Consider the following electric oven schematic, where three different heating elements are controlled by corresponding toggle switches:

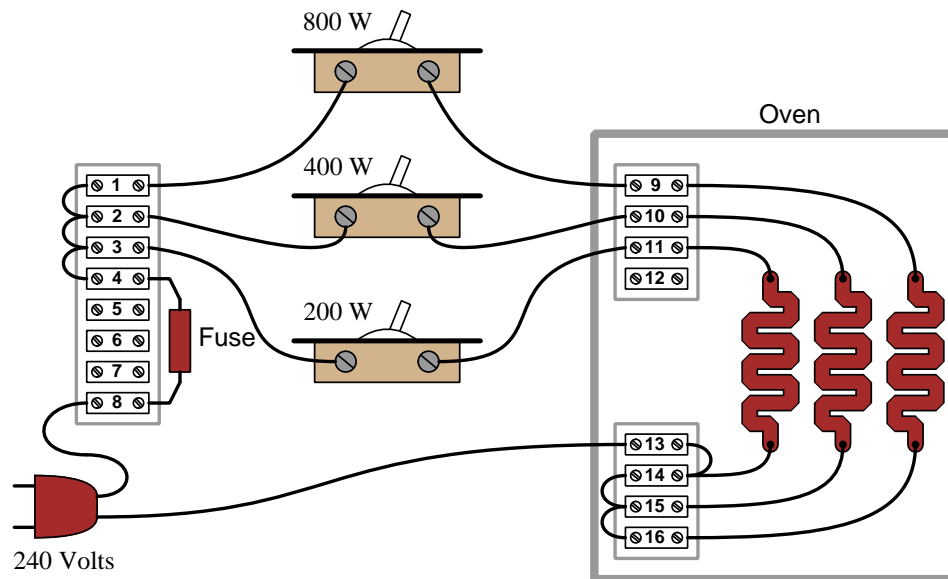

Suppose someone calls you over the telephone to request your diagnostic assistance with this oven. They tell you the 200-Watt switch didn't appear to work: when they turn on that switch by itself, the oven remains at room temperature. Based on this information, the following faults should immediately come to mind as possibilities:

- Failed-open 200-Watt toggle switch
- Failed-open 200-Watt heating element
- Dead 240 VAC power source
- Blown fuse
- Open terminal 3-4 wire
- Open terminal 3-switch wire
- Open terminal 13-plug wire
- Open terminal 13-14 wire
- Open terminal 14-element wire
- Open terminal 11-element wire
- Open terminal 11-switch wire

Now suppose while you're on your way to the oven to begin troubleshooting, you receive a second telephone call from the same person, this time informing you that they subsequently tried flipping every one of the toggle switches to find *none* of them work. Even with all three switches on, the oven remains at room temperature! Upon receiving this news, proper application of Occam's Razor would tell you that any of the previously-listed faults capable of incapacitating the whole oven are more likely than any fault that could only explain the 200-Watt element failing to heat up, since in order for such a specific fault to be true it must also be coincidentally accompanied by at least one more fault explaining why the other heating elements aren't working either. *Simply put, a single fault accounting for everything is more likely than multiple, coincidental faults where each one only accounts for part of the problem.*

By employing Occam's Razor in this way, we may "shave down" our list of likely faults to those single faults individually capable of preventing any of the heating elements from energizing:

- Dead 240 VAC power source
- Blown fuse
- Open terminal 3-4 wire
- Open terminal 3-switch wire
- Open terminal 13-plug wire
- Open terminal 13-14 wire

For example, it's far more likely that a single fault such as an open wire between terminals 3 and 4 is the cause of the trouble here, as opposed to multiple faults such as a failed-open 200-Watt heating element *and* a failed-open 400-Watt heating element *and* a failed-open 800-Watt heating element to account for none of the heating elements working. Mind you, it is not *impossible* that all three heating elements have failed open, just *less likely* than a single fault such as a loosened wire between terminals 3 and 4. Occam's Razor is all about *probability*, not certainty.

Note how much shorter this list is than the first one which we created when we only knew the 200-Watt element wasn't working! Shorter lists of possible faults are quicker to work through, and so by judiciously focusing on these most-probable faults we should be able to identify the problem in less time and with less effort. Limiting our search to the fewest faults capable of accounting for the most symptoms is key to efficient and timely diagnosis.

This is why, when troubleshooting a malfunctioning system, it is so important to collect data on the problem. With each test we perform, with each measurement we take, we learn new information helpful for "shaving" our list of possible causes to the fewest in number. This means it is wise for us to re-assess our list of possible causes with each new symptom and data point we collect.

A companion strategy when diagnosing faults in complex systems is to intentionally simplify the system (if possible), especially if the system in question is new (i.e. unproven) and therefore more likely to harbor multiple errors than a system that used to work just fine and suddenly stopped functioning. When I counsel students who find their breadboard-constructed circuits don't work when initially powered, I recommend the same: *build the simplest version of the circuit you can think of and get that simple version working before adding complexity to it.* Otherwise, if you build

the entire circuit from scratch in its full glory, it becomes more likely that you will have multiple, unrelated faults which will be more challenging to identify.

It's worth noting that the premise of Occam's Razor – that fewer faults are more likely than a multiplicity of faults – is true only when the multiple faults are unrelated to each other (i.e. coincidental). If, however, one form of fault subsequently leads to another fault, then it may be quite likely for a failed system to harbor those multiple faults. Considering our oven example, suppose the original failure was a *shorted* failure of the 200-Watt heating element. With the 200-Watt element failed-short, the fuse would immediately blow as soon as the 200-Watt toggle switch was flipped to its “on” position, leading to a non-functioning oven with *two* faults: a shorted 200-Watt heating element and a blown-open fuse. The blown fuse is not coincidental to the shorted 200-Watt element, but rather a direct consequence of it.

This leads to the concept of something called a *root cause*. A “root” cause is the source of subsequent failures, that will keep resulting in future failures if uncorrected. In the example just given of the shorted heating element and the blown fuse, the shorted element is the root cause and the blown fuse is a secondary cause: the shorted element explains why the fuse blew, but the blown fuse would explain why none of the other heating elements will energize despite their sub-circuits being in good condition.

Root causes may go even further than this simple example. Suppose after repairing the shorted 200-Watt heating element, we find it fails once more shortly thereafter. Now, our search for root cause becomes a search for the answer to why that one heating element keeps failing prematurely. Perhaps the oven is being used improperly, in such a way that causes physical damage to that 200-Watt element and makes it fail shorted. Perhaps our supplier of 200-Watt heating elements has an error in their manufacturing and/or quality-control processes such that we keep receiving defective heating elements. As you may well imagine, the search for root cause may extend far beyond the immediate scope of a malfunctioning oven, and may even involve entities beyond your responsibility or control. However, root causes being what they are, if uncorrected they will continue to spawn other failures.

Chapter 3

Simplified Tutorial

Suppose we wished to build a wind-powered sawmill, using energy¹ provided by wind to cut logs into lumber. Since lumber mills are mechanical in nature, and wind turbines provide mechanical energy (in the form of a rotating shaft turned by the turbine blades) the whole operation could be built as a single unit. The turbine turns a shaft, connected to a sprocket at the base of the turbine tower, which then drives another sprocket inside the mill by a short connecting chain, much like a bicycle chain couples the mechanical energy of a bicyclist's legs to the driving wheel. Inside the mill, saw blades moved by the chain-driven sprocket cut the logs into dimensional lumber:

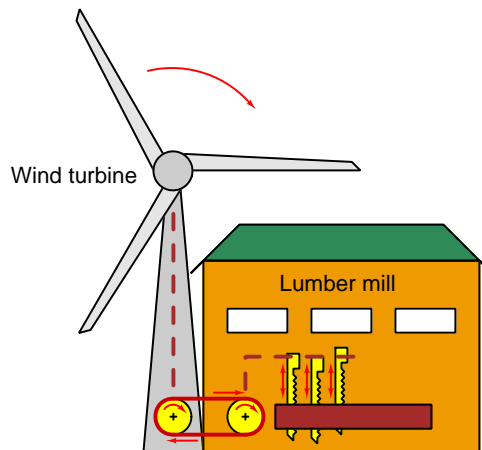

Dutch wind-powered lumber mills of antiquity were similar in concept. In order for our wind turbine to catch the most wind, though, it would have to be located on a hilltop away from all obstructions. This poses a practical problem, in that the windiest locations usually are not best for lumber mills. Logs and finished lumber are easiest to transport near a river, and rivers are usually located in valleys rather than hilltops. So, how do we convey the mechanical energy from a turbine on the hill to a mill in the valley?

¹Simply defined, *energy* is anything that is able to set matter into motion.

A direct solution to this problem is to extend the length of the chain connecting the turbine's sprocket to the mill's sprocket:

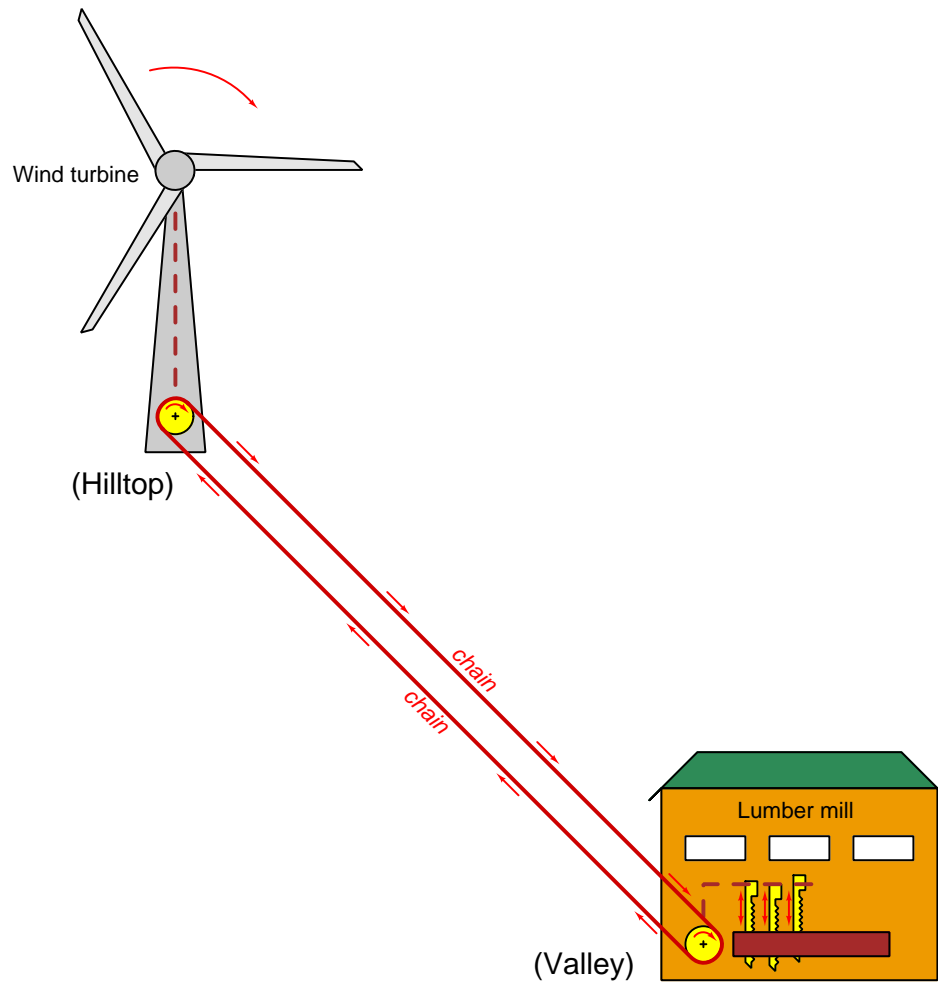

This approach, however, is impractical for multiple reasons. First, long mechanical chains are dangerous because people and animals may become injured or killed by the moving chain. Also, an open chain will prematurely wear due to dust and rain exposure. Furthermore, a chain this long requires support sprockets in between the turbine and mill to suspend its weight, and each of these support sprockets adds friction to the system which wastes energy in the form of heat. Technically, this system would function, but it would be dangerous, unreliable, and inefficient.

A better solution to this problem is a *hydraulic loop*. Here the turbine spins an oil pump which pumps oil to the mill where that moving oil spins a hydraulic motor to move the saw blades, returning the oil back uphill to the turbine's pump to be recycled:

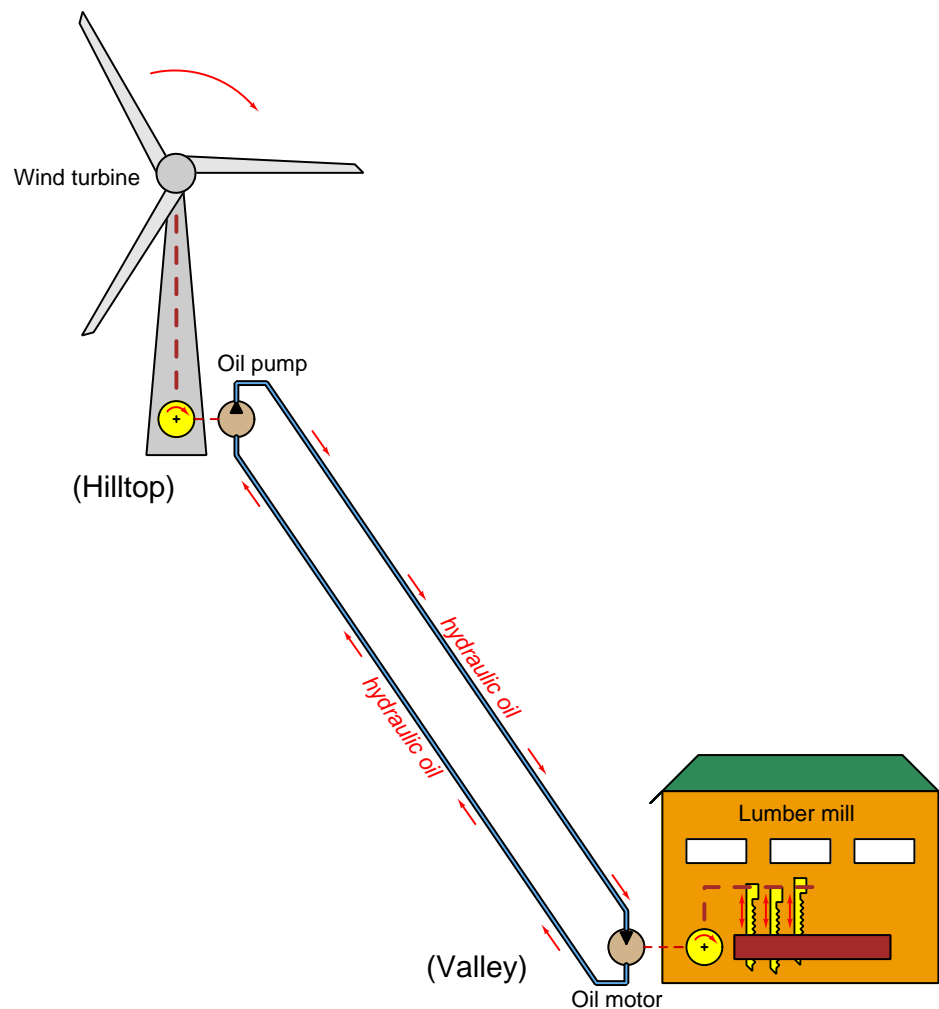

In this solution countless molecules of piped oil replace the mechanical chain. The pipes themselves are stationary and thus present no dangerous motion to nearby people or animals. The pipes are also sealed, which means the moving oil never gets exposed to the elements and will not be contaminated or diluted. Oil molecules experience less friction moving through pipes than a chain supported by extra sprockets, making this system more energy-efficient than a long chain and thereby directing a greater percentage of the turbine's mechanical energy to do useful work at the mill.

In both the chain and hydraulic systems, the unifying principle is that *something* moves in a loop from the turbine to the mill and back to the turbine to convey the turbine's energy to the mill. Whether metal links in a chain or molecules of oil inside of a pipe, the circulating medium transfers energy from one location (the turbine) to another (the mill).

It is also important to note that every bit of the energy motivating the mill comes from the wind turbine, which in turn is moved by the action of wind. No matter what kind of system we might use to transport energy from turbine to mill, the mill can never receive more energy than the turbine outputs. In other words, the chain or hydraulic oil merely *transports* energy and does not *create* any energy of its own. In fact, the mill will always receive a bit *less* energy than the turbine outputs because some of the turbine's energy inevitably² converts into heat along the way. The sum total of all energy leaving the loop (to the mill, and as heat) must equal the energy put into the loop (from the turbine)³.

Centuries ago people discovered that certain types of solid matter contained a sort of "fluid" capable of invisible motion through that matter, and like oil through a pipe could also be used to convey energy from an energy source to a point of energy use. This "fluid" was named *electricity*, and was later discovered to be subatomic particles called *electric charge carriers* that happened to be mobile in materials such as metals but immobile in other materials such as wood, plastic, glass, and air. Substances with mobile charge carriers are called *electrical conductors* while substances whose charge carriers are locked into place are called *electrical insulators*. Any continuous loop made of electrically conductive material supporting a continuous "flow" of this electricity is called an *electric circuit*.

²This is described by a physical law called the *Second Law of Thermodynamics*.

³This is described by the *Law of Energy Conservation*, otherwise known as the *First Law of Thermodynamics*, which states energy can neither be created nor destroyed, but must always be accounted for in any system.

Modifying our wind turbine / lumber mill to use electricity for energy transport, we replace the hydraulic pump and motor with an *electric generator* and *electric motor*, respectively:

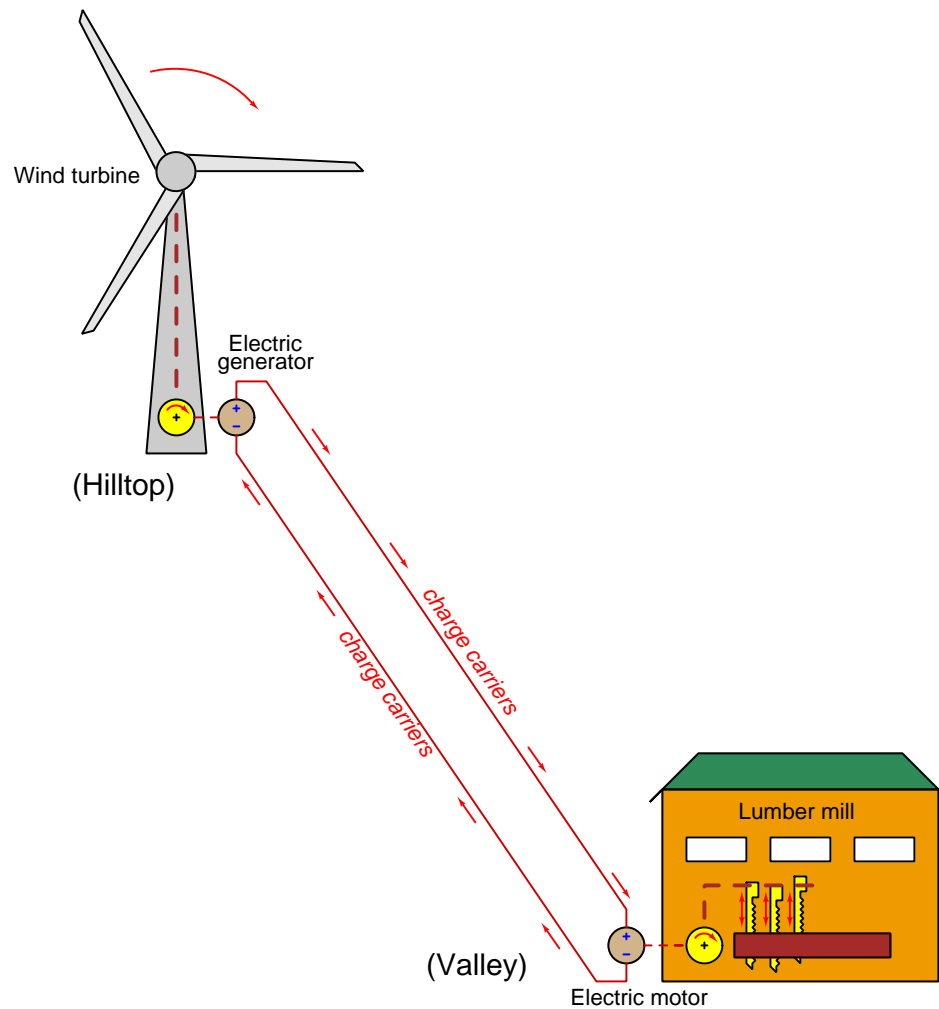

Instead of pipes connecting the hydraulic pump and motor together, we now use metal wires to connect the two terminals of the generator to the two terminals of the motor. Like the pipes, these wires are completely stationary when in use, betraying no evidence of motion within. In fact, electricity happens to be a far more efficient means of transmitting energy over long distances than either mechanical chains or hydraulic oil loops, meaning much more of the source's energy gets delivered to the point of use and less of it diverts in the form of heat. This permits the wind turbine and lumber mill to be located many kilometers away from each other while still enjoying excellent efficiency, which means we may locate the wind turbine in its best possible location and the lumber mill in its best possible location without losing much of the turbine's energy to heat along the way.

Hydraulic loops prove to be a surprisingly good analogy for describing characteristics of electric circuits. Let's compare a hydraulic loop and electric circuit side-by-side:

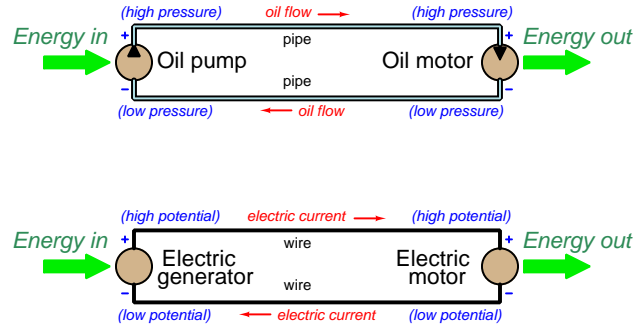

The rate of oil flowing through the pipes of the hydraulic loop is analogous to the rate at which electric charge carriers drift through the metal wires in the electric circuit, and for the electric circuit we call this drift *current*. Whereas hydraulic oil flow might be measured in units of liters per minute or kilograms per second, electric current is always measured in the unit of the *Ampere*, with one Ampere being one Coulomb⁴ of charge carriers passing by per second. In both of these simple systems, the rate of flow (current) at any given time is the same at all points because there exists only one path for the flow to take; if the current increases or decreases anywhere, it increases or decreases to the exact same degree *everywhere* in the circuit.

In the hydraulic loop the pump pressurizes the oil molecules in the upper pipe, and this pressurization constitutes energy the oil may release to the hydraulic motor at the other end of the loop, so that the oil arrives at the motor under high pressure and returns to the pump at a much lower pressure. In a similar manner, an electric generator “pressurizes” (energizes) the charge carriers on their way to the electric motor, and after delivering energy to the motor those charge carriers return to the generator at a lower energy state. In the early days of electrical engineering the relative energization of electric charge carriers was actually called *pressure*, but now we simply call it electric *potential*. In both systems we denote the high-pressure/potential line with a “+” symbol and the low-pressure/potential line with a “-” symbol.

With electricity it is practically impossible to measure electric potential as an absolute quantity, but relatively easy to compare the amount of energy carried by an electric charge at one location versus at another. The term we give to such a *difference of potential* between two points is *voltage*, and it is measured in the unit of the *Volt*, with one Volt being equivalent to one Joule⁵ of potential energy per Coulomb of electric charge carriers.

Any friction encountered by the moving oil in the hydraulic loop results in some pressure loss, and consequently energy diverted to heat. Electric circuits suffer a similar effect as well, as drifting charge carriers sometimes collide with atoms in the metal wires and consequently give up some of their potential energy also to heat. We call this electrical friction *resistance*, and measure it in the unit of the *Ohm*. Thus, in hydraulic loops there will be a measurable pressure loss or “drop” from one end of a pipe to the other due to friction, and in electric circuits there will also be a slight potential

⁴Equivalent to 6.2415×10^{18} electrons.

⁵The amount of energy needed to lift a 1 kilogram mass 10.2 centimeters upward against Earth gravity.

loss or “voltage drop” from one end of a current-carrying wire to the other. In well-designed systems these energy losses are usually so minimal as to be practically zero, but they do exist.

Our wind turbine and lumber mill system also serves to illustrate some very important concepts called *conservation laws*. A “conserved” quantity is anything that is eternal, meaning it cannot be created or destroyed but always exists in some form or another. *Energy* is one of these conserved quantities in universe. So is *mass*, and so is *electric charge*. In all three versions of the turbine/mill system we see energy conserved, in that every bit of energy extracted from the wind and imparted to the system ultimately shows up in some other form elsewhere in the system (e.g. work done in cleaving wood fibers, heat); simply put: *total energy in equals total energy out*. In all three versions of the system we also see matter being recycled in the loop without increasing or decreasing over time, whether that be links in a chain, oil molecules in sealed pipes, or electric charge carriers in metal wires.

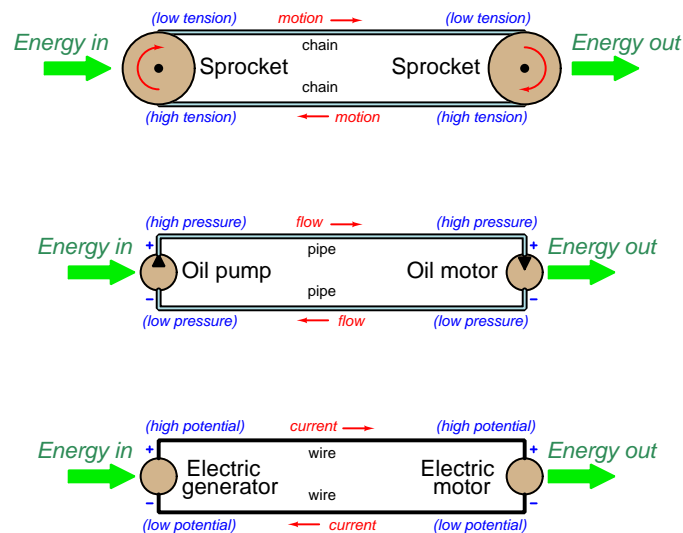

Conservation of Energy

[All three systems] – total energy out equals total energy in

Conservation of Mass

[Chain/sprocket system] – number of links in the chain never changes

[Hydraulic system] – number of oil molecules in the loop never changes

Conservation of Electric Charge

[Electric system] – number of electric charge carriers in the circuit never changes

Chapter 4

Full Tutorial

4.1 Potential energy

Imagine walking into a gymnasium and noticing a 30 kg iron weight on the floor. If I were to ask you how hazardous that weight was, resting on the floor, you might think I was setting up a joke because an iron weight resting at ground level poses no threat to anyone at all.

What if we perched this same 30 kg weight precariously on a shelf 3 meters high? Now the question of hazard is no joke at all – a 30 kg weight falling 3 meters to ground level is capable of inflicting serious harm!

Now imagine lifting that same 30 kg weight to the top of a building and setting it on the edge of the roof. Here, the hazard needs no explanation at all: falling from that height, a 30 kg weight would be *lethal*.

What, exactly, determines an object's falling hazard? It cannot simply be the object's *mass*, because mass was identical in all three scenarios despite the varying levels of danger: whether resting on the floor, on a shelf, or at the top of a tall building, it was still a *30 kg* weight. Nor is *height* the only danger factor, because we can easily imagine other things at similar or even greater heights posing no hazard whatsoever: a raindrop falling from a height of several kilometers, or a speck of dust atop a shelf. Clearly, neither mass nor height alone determines the degree of hazard.

By now, the correct conclusion should be obvious: it is the *combination*¹ of an object's mass and height that determines its ability to do harm when dropped. In the study of physics we have a single term for this quantity: a combination of force (in this case, the weight of a mass drawn by gravity) and displacement (falling distance) which we call *energy*. Simply put, energy is the ability to set matter into motion.

A 30 kg weight resting at ground level has no ability to set matter into motion. If we raise that weight to some height, though, now it possesses the potential to move² things. We call this latent capacity *potential energy* because it is not realized until the weight begins to fall. As the weight falls, that potential energy (weight combined with height) gets converted³ into *kinetic energy* (mass combined with speed) which also has the capacity to move (other) things.

Potential energy, however, is not as simple as combining weight and height. To illustrate, consider a 30 kg weight located in a gymnasium in a different city at an altitude thousands of meters higher than the first. Clearly, the 30 kg weight located in the high-altitude city possesses a greater absolute height than the 30 kg weight located in the low-altitude city, yet neither weight poses any falling hazard whatsoever while resting on its respective floor. The same three scenarios explored earlier (weight at ground level, on a shelf, or on the top of a tall building) would still hold true in the high-altitude city, so height still clearly matters, but each city's altitude relative to sea level appears to be irrelevant.

Sharpening our definition of energy, we must consider the height of any mass as a *relative* rather

¹Mathematically, energy (E) is the product (multiplication) of force (F) and displacement (x): $E = F \cdot x$. When the force in question is the object's weight (W) and the displacement is the vertical height (h) above ground, the energy formula may be alternatively written as $E = Wh$.

²In the context of safety, the moving of things we are concerned with is primarily the *crushing* of flesh and bone, and secondarily the damage to fragile objects which might occur as a result of the weight falling on them.

³This is why the weight's falling speed increases as its height decreases: kinetic energy increases as a result of potential energy decreasing, the sum total of potential and kinetic energy remaining constant because it is conserved. After impacting the ground, the weight possesses neither potential energy nor kinetic energy, all that energy having been translated into other forms during the impact (e.g. heat, sound, compression of soil).

than an *absolute* quantity. A weight's potential energy is a function of both its mass and how far it is liable to fall. A 30 kg weight on a shelf possesses the same amount of potential energy (i.e. the ability to set matter into motion) as a 30 kg weight perched on an identical shelf at some other altitude above sea level, because in both cases the height⁴ of its potential fall is the same. Stated differently, *potential energy is only quantifiable between those two points defining the amount of displacement.*

4.2 Conservation laws

A close study of matter and energy reveals a rather startling truth: *energy is eternal*, meaning it can never be created or destroyed, only converted between different forms. The 30 kg weight perched on a shelf didn't get its energy from nowhere – someone had to place it there, and that person had to expend energy hoisting the weight up to that location. That person's energy didn't spontaneously appear, either, but originated from food eaten at some earlier time. The energy contained in that food, in turn, came from sunlight falling on plants which used that solar energy⁵ to grow.

As we see here, energy exists in many different forms. Elevated and moving masses are only two forms of energy, other forms including but not limited to *heat* (molecules in vibrational motion), *light*, *chemical energy* (atoms ready to bond with each other and thereby set matter into motion), *nuclear energy* (subatomic particles in the nuclei of atoms ready to shift into more stable arrangements), and *spring tension* (a spring compressed or stretched by an external force). The fact that energy so readily shifts form but yet never disappears or appears from nowhere is a profound feature of the universe we inhabit, and it is a very useful fact because it permits us to make precise predictions about matter in motion. We call this the principle the *Conservation of Energy*, or the *Law of Energy Conservation*.

As it so happens, energy is not the only conserved quantity in the universe. Mass⁶ is also eternal: like energy, mass is impossible to create or destroy, but may change into different forms. Other Conservation Laws exist, describing such quantities as *momentum* and subatomic particle "*spin*", but these are not relevant to our study of electricity.

⁴This is where the term *displacement* mentioned earlier shows its utility. A displacement is a distance of motion, and as such it has both a starting point and an ending point. "Height" is somewhat ambiguous because the point of reference is not clearly defined, whereas "displacement" implies a definite start and end.

⁵The sun, in turn, gets its energy from an enormous internal repository of hydrogen gas which it uses as fuel for its nuclear fusion reaction. Where the energy came from to form that hydrogen fuel is something of a mystery.

⁶Mass is the opposition to acceleration or deceleration. Although mass and weight are related, they are not identical. Technically speaking, *weight* is the force exerted on a mass by a gravitational field, while mass is an intrinsic property independent of any external influence. That 30 kg iron weight would weigh nothing in the zero-gravity environment of deep space, although it would still possess mass (being just as resistant to acceleration or deceleration).

4.3 Electric potential and voltage

What does all this talk of falling weights have to do with electricity? Just as any mass placed within a gravitational field experiences a force we call *weight*, certain types of matter possess a property called *electric charge* which similarly experiences a force when placed within an *electric field*⁷:

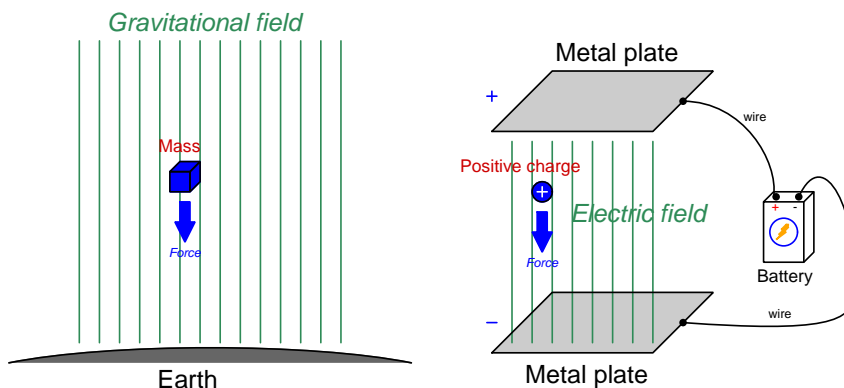

An electric charge experiences a force when exposed to an electric field, just as a mass experiences force (called "weight") when exposed to a gravitational field

Electric charges take two different forms, called *positive* and *negative*. Opposite charges (i.e. positive versus negative) attract one another while like charges (i.e. positive versus positive, and negative versus negative) repel one another. If we were to place a negative charge within the same electric field illustrated above, it would “fall” upward toward the positive metal plate just as the positive charge “falls” downward toward the negative plate. Electric charges happen to be conserved just like mass: *electric charges cannot be created or destroyed, but are eternal*.

An electric field exerts a force on any electric charge placed within it, in this case repelling the charge away from the like pole and attracting it toward the opposite pole. This is similar to the force gravity exerts on a mass, except that with mass and gravity there are no “positive” and “negative” identities. If any external energy source overcomes this force and causes the charge to move toward the field’s like pole, we increase that charge’s potential energy, just as when we lift a weight upwards against Earth’s gravity. If the charge “falls” toward the field’s opposite pole, it loses potential energy just as a weight falling to the ground loses potential energy.

An investment of energy is necessary to move any object against the natural force imposed by a field, for example an engine hoisting a mass upward against the force of gravity, or some external influence moving the positive electric charge closer to the positive plate and away from the negative plate. Conversely, energy is released when the object “falls” in the direction imposed by the field. *Work* is the scientific term used to describe a gain or loss of energy for some particular object or portion of a system. We would say that the external agency *does work on the object* when “lifting” it against the field’s force.

⁷ *Fields* are interesting concepts, being invisible “webs” of interaction propagating through space. Many types of fields exist besides gravity, and each type of field has its own unique properties. Gravitational fields interact with matter. Electric fields interact with electrically charged matter. Magnetic fields interact with *moving* electric charges. These fields propagate through space at the speed of light (approximately 3×10^8 meters per second).

Atoms contain electrically-charged particles, and these electric charges experience forces and changes in energy when moved relative to each other. Orbiting *electrons* are tiny particles of matter carrying a single negative charge each, while *protons* are larger particles (still very tiny!) located in the center (nucleus) of the atom and carrying a single positive charge each. *Neutrons* are slightly more massive than protons, but carry no electric charge whatsoever. The electric fields naturally formed between electronic and protons exert an attractive force, one to the other, but have no effect on the neutrons because they are electrically “neutral” and are therefore unaffected by electric fields. Electrons are very mobile within an atom, attracted to the positively-charged nucleus but repelled from each other. The protons would be forced away from each other by the same electric repulsion as the electrons if they were not tightly bound together by a much stronger force⁸:

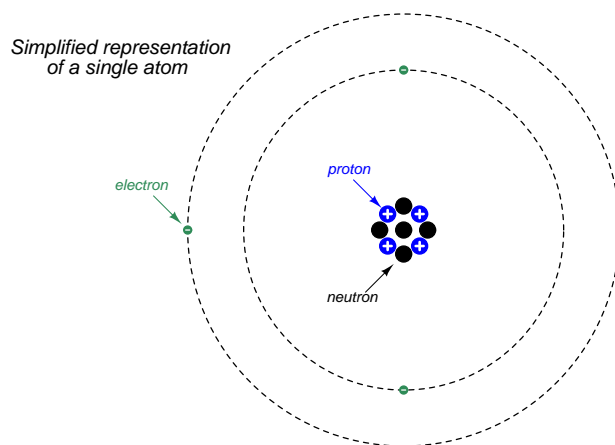

If we perform work on this atom by investing sufficient energy into it from an external source, we may cause one or more of its electron to jump into a higher orbit, “lifting” it farther away from the nucleus it’s attracted to, and thereby boosting that electron’s potential energy. When that electron “falls” back into its original position, it loses that potential energy it was given, the work done by the falling electron converting into another form such as heat or light. This exchange of energy, from some outside source to an electron, and then from that electron to another form such as heat or light, is how gas-discharge electric lamps function: electrical energy “excites” gas atoms such that some of the electrons get boosted to higher orbits, and when those electrons “fall” back down to their original orbits they emit energy in the form of colored light.

Work done on or by electrons also explain *chemical reactions*, which are instances of atoms bonding with other atoms and/or splitting apart from other atoms, those bonds consisting of exchanges of electrons from atom to atom. The energy absorbed or released by a chemical reaction is the result of electrons achieving higher or lower energy levels, respectively.

⁸This stronger force binding all the protons and neutrons together in the atom’s nucleus is called the *strong nuclear force*, and it is the phenomenon exploited in both nuclear fission and fusion reactions.

Electricity is the word we use to describe various phenomena related to the motion of electric charges within matter. In certain materials such as metals, some of these electric charges are quite mobile, capable of drifting from atom to atom when influenced by external electric fields. As these mobile electric charges gain and lose energy within those electric fields, they provide a means to transfer energy from one physical location to another. This is the basis of electric power systems: using mobile electric charges to move energy across large distances.

In most cases it is impractical to precisely quantify the amount of potential energy possessed by any object influenced by a field, but it is much easier to quantify how much energy it gained or lost – i.e. how much work was done to it or done by it – from one condition to relative to another. Recall the 30 kg weights located in different cities: the amount of energy each weight could potentially deliver when falling depended only on how far it could have actually fallen if released (i.e. from its current location to ground level in that city). In principle we could argue that a 30 kg weight located in a city 1000 meters above sea level possesses five times the potential energy of a 30 kg weight located in a city 200 meters above sea level, but this five-fold ratio of energy tells us nothing about the hazard such a weight might practically pose falling from a shelf in either city. Only the distance from its resting place to the floor matters for that question.

In the study of electricity we have a special term to describe this relative change in energy, or work, and it is called *voltage*. We quantify voltage by the unit of the *Volt*, defined as one Joule of work done per Coulomb of electric charge⁹. If 30 Coulombs of electric charge either gains or loses 120 Joules of potential energy moving from point A to point B, we would say there is a *4 Volt potential difference* between those two points. It is meaningless to speak of how much potential energy this 30-Coulomb charge might have at any single location without reference to some other location, just as it would be meaningless to speak of the amount of potential energy possessed by a 30 kg weight without referencing a second location it could be lifted to or fall to.

Relativity of potential energy

Potential energy is always relative between two different conditions. Voltage, being a measure of electrical potential energy, has meaning only as a measurement between two locations.

This is arguably the most confusing aspect of electricity: the fact that voltage exists only between pairs of points, and has no practical meaning at any single location. Voltage is fundamentally *relative between two points*, an expression of work done by or on an electric charge if it were to move from one location to another. To try to speak of voltage existing at a single location is nonsense, just as it would be nonsense to speak of “distance” existing at a single point without reference to some *other* point of comparison.

⁹One Joule is equivalent to one Newton of weight (the force generated by approximately one-tenth of a kilogram exposed to Earth gravity) displaced one meter parallel to that force, and one Coulomb of charge is equal to 6.2415×10^{18} electrons’ worth of electric charge.

4.4 Electric resistance, current, and circuits

Electricity is the study of mobile electric charges, and the energy involved in the motion of those charges. Some substances easily permit electric charges to move within them, and we refer to these substances as *conductors* of electricity. Other substances exhibit great opposition to the motion of electric charges, and we call these substances *insulators* of electricity. The degree to which a substance inhibits the flow of electric charges is called *electrical resistance*.

Metals are typically good conductors of electricity, the bonds between metal atoms being such that the electrons are free to drift from atom to atom while the nuclei of those atoms remain fixed. Some liquids are good conductors of electricity because their molecules (which are mobile in any liquid) dissociate into electrically-imbalanced *anions* and *cations*. All gases are insulators unless they become energized to the point where the electrons are forcibly stripped away from the atomic nuclei, at which point the gas becomes a *plasma* consisting of free electrons and cations. In the presence of an electric field, electrons will drift through a metal while the atomic nuclei remain at rest; liquid anions and cations will migrate in opposite directions; free electrons and cations in a plasma likewise migrate in opposite directions. Any mobile entity possessing an electric charge is a *charge carrier*, whether it be a single subatomic particle or an ion, whether it be positive or negative. In any case, the net¹⁰ motion of electric charge carriers through a substance is called an *electric current*.

Early experimenters described electricity as a *fluid*, and this happens to be a surprisingly good analogy. A fluid, after all, is any form of matter capable of *flow*, and since electric charge carriers are able to flow through electrically-conductive materials it is fair to refer to them collectively as a type of fluid. We may illustrate the concepts of voltage, current, and resistance by presenting two simple *circuits* (a “loop” where a fluid may move in an unending cycle). In the electric circuit we have a battery, an electric motor, and connecting wires. In the hydraulic “circuit” we have a pump, a turbine, and connecting pipes:

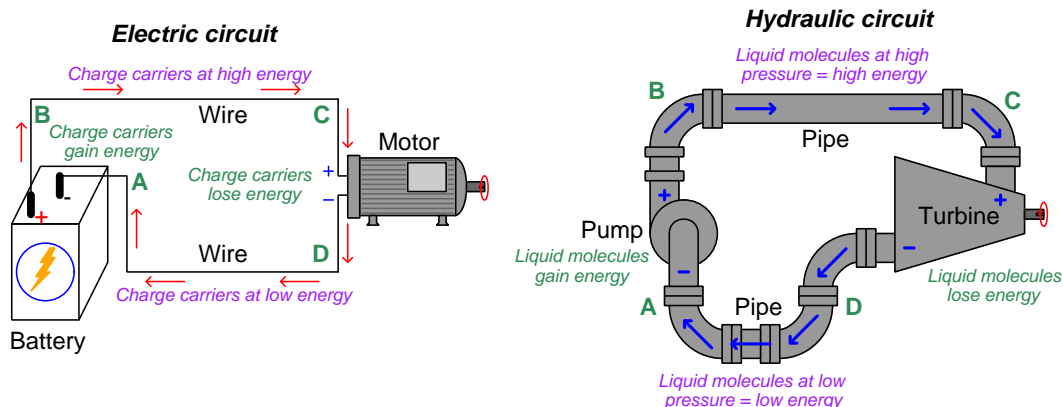

Both systems convey energy from a *source* to a *load* through the medium of a fluid. In each case some “source” device imparts energy to the fluid (i.e. does work on the fluid): the battery

¹⁰Electric charges often move randomly through substances as a function of thermal energy, especially in the case of metals and conductive liquids. Electric current is simply the *average drift* of these charge carriers.

uses chemical reactions to impart energy to mobile electric charge carriers, while the pump relies on mechanical motion provided by another machine to impart energy to mobile liquid molecules. In each case a “load” device extracts energy from the fluid (i.e. allows the fluid to do work): the electric motor uses magnetic fields to convert potential energy of the charge carriers into mechanical motion, while the turbine uses curved blades to convert the energy of the moving liquid into mechanical motion. In the electric circuit, *voltage*¹¹ is the amount of energy gained or lost by charge carriers moving from one location to another. In the hydraulic circuit, *head*¹² is the amount of energy gained or lost by liquid molecules moving from one location to another.

The “+” and “−” symbols you see in both circuit illustrations expresses this relative gain or loss of potential energy by the fluid as it circulates around each system. Note how fluid enters the negative (−) end and exits the positive (+) end of a source (battery, pump) as it accumulates potential energy from that device, and then enters the positive (+) and exits the negative (−) of a load (motor, turbine) as it relinquishes energy to something else outside of the circuit.

The Law of Energy Conservation is instructive for both systems – in each case, the load cannot deliver any more energy than it receives from the source. In each case, the fluid in question is merely a medium for energy transfer from one location to another, the total amount of energy remaining constant at all times as it shifts location. The Laws of Mass and of Electric Charge Conservation also hold true: in the electric circuit the total count of electric charge carriers never varies as those charge carriers flow through the circuit; in the hydraulic circuit the total number of fluid molecules similarly remains constant as the liquid circulates.

Resistance is a term used to describe the extraction of energy from any fluid moving in a circuit. In the electric circuit the motor resists the flow of electric current as it extracts energy from those moving charge carriers to produce mechanical work. In the hydraulic circuit the turbine resists the flow of liquid as it extracts energy from those moving molecules to similarly produce mechanical work. Anyone familiar with using exercise machinery knows this concept well: a machine providing more *resistance* extracts more energy from your body as you labor to move the mechanism.

The amount of resistance offered by the electric circuit’s connecting wires or the hydraulic circuit’s connecting pipes is minimal, and as a result there is little difference in fluid potential energy from one end of a wire or pipe to the other. In the electric circuit we will find negligible voltage from one end of a connecting wire to the other. In the hydraulic circuit we will find negligible liquid pressure difference from one end of a connecting pipe to the other.

¹¹This standard quantity is called the Coulomb, and it is equivalent to the charge of 6.2415×10^{18} protons or electrons (since protons and neutrons both exhibit the same magnitude of charge, only opposite in sign.).

¹²Fluid head may take potential-energy form as pressure or as elevation (for dense fluids where gravitational potential energy can be significant), and/or kinetic-energy form as velocity. Bernoulli’s Equation is a mathematical expression of these three heads applicable to any location within a fluid system: Total head = $z\rho g + \frac{\rho v^2}{2} + P$ where z is elevation (height), ρ is the mass density of the fluid, g is the acceleration of gravity, v is fluid velocity, and P is fluid pressure. In this equation $z\rho g$ represents the *elevation head*, $\frac{\rho v^2}{2}$ the *velocity head*, and P the *pressure head*.

4.5 Concept review

Let us review some important concepts. *Energy* is the ability to put matter into motion, and it cannot be created or destroyed, but it can be transferred from one place to another and it may change form. *Potential energy* is energy that is not yet causing matter to move, but may do so under the correct conditions. Masses elevated within a gravitational field possess potential energy because they *can* fall, even if they are not falling at the present moment. Electric charges “elevated” within an electric field also possess potential energy. The amount of work done on (i.e. potential energy absorbed) or done by (i.e. potential energy released) each electric charge as it moves between two different locations is called *voltage*.

Electric *circuits* are circulations of electric charge carriers, absorbing energy from one location at a device known as a *source* and releasing energy to another location at another device known as a *load*. In a simple battery-motor circuit, the battery is the source doing work on charges passing through it, and the motor is the load where those charges do mechanical work. The flow of electric charges around a circuit is called an electric *current*. *Resistance* refers to the work done by (i.e. energy extracted from) electric charges moving through a load.

Positive (+) and negative (−) symbols represent the relative energies of charge carriers passing through any component, with “−” meaning lower energy and “+” meaning higher energy. Therefore, charge carriers enter as “−” and exit as “+” at a source device, gaining energy (i.e. having work done on them) as they pass through that source. Charges enter as “+” and exit as “−” at a load device, losing energy (i.e. doing work) as they pass through that load.

These *polarity* symbols have meaning only as *pairs*, because voltage is by its very nature a relative quantity between two points. Just as there is no such thing as voltage existing at any one location, an isolated “+” or “−” polarity symbol likewise is meaningless. Voltage always is an expression of potential energy either gained or lost by electric charges moving from one point to another, just as distance is the expression of physical separation between two points. It would make no sense at all to ask “What is the distance of Paris, France?” but it would be a legitimate question to ask “What is the distance *between* the Paris, France and Dublin, Ireland?” in the same way that it would be nonsensical to inquire of the voltage at point “A” but entirely appropriate to measure voltage *between* points “A” and “B”.

Physical analogies of electricity, imperfect though they may be, help us envision the behavior of real electric charges. Multiple analogies are presented here:

- **Elevators and masses:** each mass represents an electric charge carrier, the rate of masses ascending or descending within the elevator represents current, and height changes represent voltage. Masses require energy to lift them (from $-$ to $+$ height) and return energy when falling (from $+$ to $-$ height). Horizontal motion requires no height change (i.e. no voltage).
- **Liquid pumped through a hydraulic loop:** liquid molecules represent electric charges, their rate of flow represents current, and the pressure gained or lost as liquid passes through each component in the hydraulic circuit represents voltage. Energy delivered by the pressurized fluid to a hydraulic actuator or motor ultimately comes from the pump or other source pressurizing the liquid. Liquid molecules traveling through non-restricting pipes neither lose nor gain any pressure.
- **Tractors traveling between a fuel station and a field:** tractors represent electric charges, the number of tractors per day represents current, and the change in each tractor's fuel level represents voltage. Tractors doing useful work (e.g. plowing fields) convert their fuel's potential energy into action, and in so doing deplete their fuel reserves (i.e. from $+$ to $-$). Those same tractors get refueled when they pass through a fuel station (i.e. from $-$ to $+$), and are ready to repeat the cycle. Roads linking the fuel station to the fields are perfectly level and frictionless, so the tractors coast between those points and use no fuel traveling to and from the field (i.e. zero voltage from one end of a road to the other).
- **People transferring money:** each person represents an electric charge, their rate of travel between a money source and an expense represents current, and the amount of money either gained or lost by each person traveling between any two points represents voltage. No money is spent in transit, but when a person encounters an expense, it costs them money. The result is each person is richer ($+$) prior to encountering the expense and poorer ($-$) afterward; upon returning to their money source each person enters poorer ($-$) and leaves richer ($+$) as they receive more money (energy).

4.6 Energy transfer in circuits

We may explore the concept of energy transfer and voltage in more detail by adding one more element of resistance to each circuit:

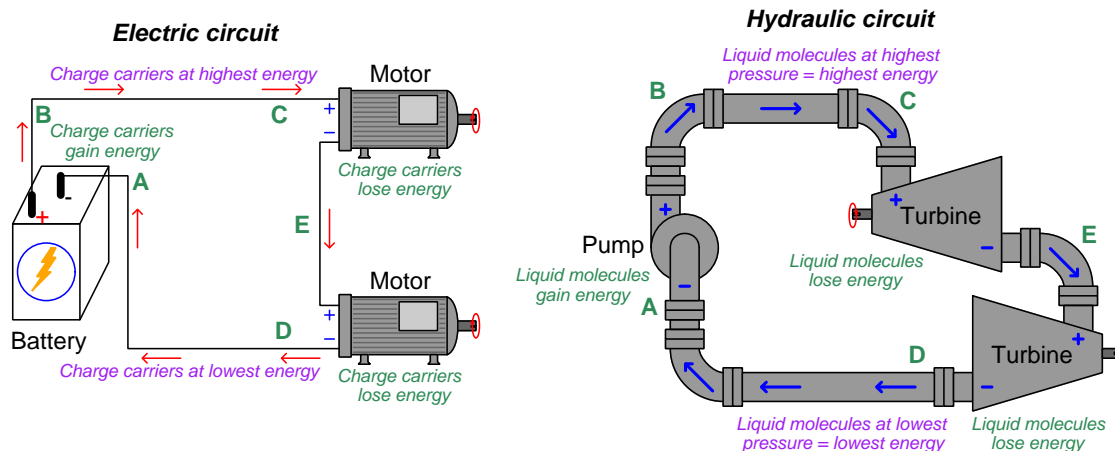

In each case we have one “source” device boosting the particles’ energy level (battery, pump) and *two* “load” devices drawing energy from those particles to do work elsewhere. Each of the energy-extracting devices (motors, turbines) now operates on a fraction of the energy input by its respective source. Using proper terminology, we may say each of the motors experiences a fraction of the battery’s voltage, and that each turbine experiences a fraction of the pump’s head.

From these illustrations it should be clear that voltage, like fluid head, *is always a quantity relative between two points*. If the voltage between points C and E is equal to the voltage between point E and D, then each one of those voltage “drops” will be exactly one-half the voltage of the battery (between points B and A). It is nonsense to speak of either voltage or head at any single location without another point of reference because voltage is an expression of potential energy *difference* between two locations.

It should also be clear from these illustrations that negligible voltage exists between points connected by negligible resistance, for example between points B and C, or between points D and A, simply because charges may move freely between those points without doing any work. The electrical term for this is *equipotential points*, meaning electric charge carriers at those different points possess the same amount of potential energy¹³. One way to ensure points are equipotential to each other is to make them *electrically common* to each other by directly connecting them using a good conductor. Points B and C are equipotential, as are points A and D, because they are electrically common (i.e. joined by pathways of negligible resistance). Points A and B, however, are not equipotential because the battery ensures charges at those two points exist at different energy levels. Neither are points

¹³A noteworthy exception to this principle is in cases where energy is applied to a circuit in pulsations occurring faster than the energy is able to propagate. In such cases, *waves* of voltage may occur along the length of conductors, similar to waves occurring over large bodies of water. For the sake of this introduction, however, we will assume electrical circuits and fluid systems exist in steady-state conditions where waves are not present.

C, D, or E equipotential to each other while there is flow because energy is extracted from the moving charge carriers as they pass from C to E to D. Any points capable of existing at different potentials are *electrically distinct* from each other. Electrically common points, by contrast, *must* be equipotential or very nearly equipotential due to the lack of significant resistance between them.

As was mentioned previously, electric *current* is the measure of average charge carrier motion. It is analogous to the rate of liquid flow in the pump and turbine system. While the liquid's flow rate may be measured in terms of standard volumes (e.g. liters or gallons) per second, the flow rate of electricity may be measured in terms of standard quantities of electric charges passing by per second. Unlike voltage, current is definable at any single point in a circuit. In a simple circuit such as those seen here, where only one path exists for the flow and all conditions are assumed to be "steady-state" (i.e. no rapid changes in voltage or current), we would expect to see precisely the same flow rate at all points along the circuit¹⁴.

It should be noted that electric current is defined in the same manner regardless of the type of charge carrier. If the current happens to flow through a solid metal where only electrons are mobile and the positive nuclei of the metal atoms are fixed, the rate of current is defined in terms of standard quantities of electrons passing by per second. If the current happens to flow through a liquid, where positive "cations" drift one direction and negative "anions" drift another direction, the number of standard electrical charges per second is the same in either direction. In fact, the direction we choose to represent charge flow in a circuit is somewhat arbitrary. Historical convention and modern engineering notation shows electric current as the flow of positive charge carriers, exiting the positive (high-energy, or "+") side of a voltage source and returning to the negative (low-energy, or "-") side of a voltage source¹⁵.

Resistance, like voltage, is a quantity relative between two points because it is the total amount of opposition electric charges encounter traveling from one location to another. Just as it is nonsense to try to speak of voltage existing at a single point in a circuit, it is equally nonsensical to speak of resistance as existing at a single point: in either case, both the starting and ending points must be defined. Whether speaking of voltage or of resistance, the quantity in question is defined by the *journey* charges must take as they move from one location to the other. The electrical resistance offered by each motor, for example, is measured from one terminal of the motor to the other, and not at any one specific point within the motor.

Examine the battery-motor circuits shown previously and take note of the "+" and "-" symbols

¹⁴The same noteworthy exception applies to current in a single circuit (loop) as to voltage along an equipotential conductor: if energy is applied to a circuit in pulsations faster than the speed of energy propagation, *waves* will develop where the current at one point in the circuit is not the same as in another point in the same loop. For the sake of simplicity, though, we will ignore such cases and assume our circuits all function in steady-state conditions where voltage is nonexistent between equipotential points and current is precisely equal at all points in a loop at any given moment.

¹⁵This is often a source of confusion for students new to electricity: we learn that the only charge carriers in metal conductors are electrons, which have a negative charge, yet in every circuit built of metal wires we commonly see arrows representing the motion of *positive* charge carriers. Some texts prefer to show the actual direction of electron motion through metal wires, which is called *electron flow notation*. However, the vast majority of engineering references show current going the other way (called *conventional flow notation*), and in fact directional electronic components such as diodes and transistors actually have arrows built into the symbols showing the direction of current in "conventional" notation. This tutorial series will exclusively use conventional notation unless specifically noted otherwise.

used to mark voltage across each component. You will see how these markings indicate the relative energy states of charges as they journey through each component. At the battery, for example, we see charges entering the “−” side (low energy) and exiting the “+” side (high-energy), because the battery is infusing each electric charge carrier with energy obtained from its internal store of chemical reactants. At each motor, however, we see charges entering the motor at high energy (“+”) and leaving the motor at a lower energy (“−”) because the motor is drawing energy away from the electric charges in order to perform mechanical work (i.e. force combined with motion). These polarity marks must be interpreted in *pairs*, indicating either a gain or a loss of energy for electric charges passing through. The direction of these charges’ motion through the component relative to the polarity marks tell us whether the component is investing energy in the charges or extracting energy from them.

4.7 Causes of voltage, current, and resistance

Voltage may be generated in several different ways. Batteries use energy stored in chemical compounds to motivate charge carriers to elevate their energy levels. Mechanical friction between objects may also generate voltage: this is how *static electric charges* are created by rubbing dry materials against each other. Some minerals are known to create voltage when physically stressed, a phenomenon known as *piezoelectricity* (i.e. electricity from pressure). Conductors may generate voltage when exposed to a temperature gradient, a phenomenon known as the *Seebeck effect*, employed by so-called *thermo-electric generators* which convert heat directly into electricity. *Light* may be used to excite charge carriers in certain substances and thereby create voltage, a phenomenon known as the *photoelectric effect*. This basic principle finds application in *photovoltaic cells* used to generate electricity directly from sunshine.

By far the most common means of generating voltage, though, is *electromagnetic induction*, which is the effect that happens when a conductor is exposed to either a strengthening or weakening magnetic field. Nearly every electrical power plant in the world uses mechanical generators turned by various prime movers (e.g. wind turbines, water turbines, heat engines) wherein strong magnets are passed by coils of metal wire. The magnetic field experienced by these wire coils grows and ebbs with the passing of the magnets, thereby generating voltage across the length of the coils.

Current results when electrical charges are given the opportunity to return to a lower energy state. If we apply a voltage across an electrical resistance, a current will flow through that resistance directly proportional to the magnitude of the voltage and inversely proportional to the resistance offered. This proportionality is mathematically codified in *Ohm's Law*, a topic for a future tutorial.

Resistance transfers of energy away from moving charge carriers and into a form that leaves the circuit entirely. The resistance of the electric motor extracts energy away from the charges, turning that energy into mechanical force and motion which then dissipated into the surrounding environment as physical work, never to return to the circuit. The resistance of a metal wire (caused by random collisions of electrons as they drift through the metal lattice) causes that wire to increase temperature and radiate thermal energy into the surrounding air¹⁶. An electric lamp takes energy from the moving charges and converts it into light and heat. Like the motor, the energy extracted by the lamp goes into the surrounding environment never to return to the circuit. An *electrochemical cell* is a device using an electric current to force a chemical reaction to occur. In this case, the energy extracted from electric charges by the cell is invested in the products of that chemical reaction, raising their energy states in the process. A rechargeable battery is a form of electrochemical cell where the extracted energy is stored in chemical form for later use. An *electrolysis cell* using electricity to separate water molecules into hydrogen and oxygen gases stores that energy in the flammability of the hydrogen, that energy being reclaimed for useful work when the hydrogen is later burned as a fuel.

¹⁶Since the resistance of conductors is purposefully made as low as possible, this heating effect is typically minimal. However, a conductor that is “overloaded” with too much electric current may become hot enough to ignite flammable substances nearby or even melt! This is why electric circuits are almost always provided with overcurrent protection to shut off the current in the event it becomes excessive. One simple form of overcurrent protection is a *fuse*, which is nothing more than a thin strip of metal designed to melt and break into two pieces with excessive current. In effect, a fuse is a “weak wire” purposefully installed in an electric circuit.

4.8 Opens and shorts

A very important pair of concepts related to voltage, current, and resistance are *opens* and *shorts*. An “open” is when a formerly conductive path for electric current is broken by an insulating gap, such that current can no longer exist at that point. A “short” is when two formerly isolated points in a circuit are joined together by a conductive path, making those two points electrically common with each other¹⁷ and therefore equipotential (i.e. no difference of potential between them). An “open” condition guarantees zero current, because charge carriers are unable to pass through the insulating gap. An open condition also permits voltage to exist between those two points where were formerly connected (equipotential). Conversely, a “shorted” condition guarantees zero (or nearly zero) voltage between those shorted points, and permits the passage of current where none could flow before.

Both “opens” and “shorts” may occur accidentally, or be inserted intentionally into a circuit for any number of reasons. Opens commonly occur when a conductor breaks or otherwise becomes disconnected from another conductor. Shorts commonly occur when the insulating material sheathing a conductor becomes stripped away, cracked, melted, or otherwise compromised such that it allows the conductor to come into contact with another conductor. Also, a short may be intentionally placed into a circuit by means of a temporary “jumper wire” inserted between the two points to be shorted.

Opens and shorts may be cast in terms of resistance, being *limiting cases*¹⁸ of high and low resistance, respectively. Unlike resistance, which transfers energy away from a circuit, idealized opens and shorts manifest no energy loss at all. However, opens and shorts greatly affect the transfer of energy elsewhere in the circuit which is why they are so important for us to understand.

When circuit components fail, they often do so in a way resembling opens and shorts. A “failed open” component is one where the internal path for current becomes broken, or at least becomes highly resistive. A “failed shorted” component is one where the resistance of its internal current path decreases to nearly zero.

A class of electrical components called *switches* create open and shorted conditions on demand. When a switch is “opened” it means its mechanism moved in such a way as to sever a metal-to-metal connection and thereby prevent electric current through it. When a switch is “shorted” or *closed* it means its mechanism moved to bridge two points by direct contact with metal:



¹⁷Sadly, some people colloquially use the word “short” as a descriptor for *any* type of electrical fault. In the study of electric circuits, however, the term “short” has a very specific, technical meaning: the joining together of two points by a conductor of negligible resistance.

¹⁸A “limiting case” is nothing more than the end of a continuum, and as a problem-solving concept is extremely useful. Here, we use this construct as a way to relate new concepts (opens and shorts) to a previous concept (resistance).

A concept relevant to switch function is *electrical continuity*: whether or not a continuous path for current exists. A “closed” switch exhibits continuity, while an “open” switch does not.

Let us consider how an “open” affects circuits, both electric and hydraulic. In the electric circuit, the “open” is simply a cut¹⁹ made on the wire attaching to the positive (+) terminal of the battery; in the hydraulic circuit, the “open” is a gap in a pipe with the pipe ends blocked off by metal plates called *blinds* preventing liquid from moving through that pipe:

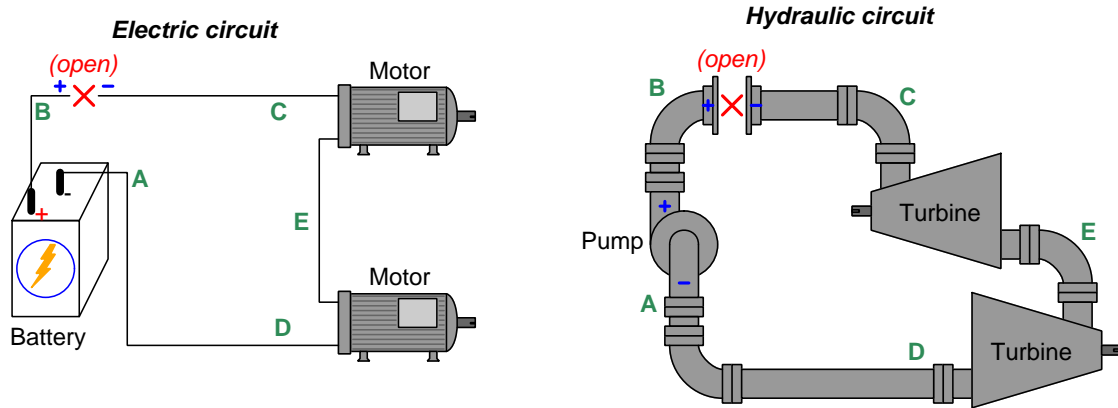

In either case, the “open” forces flow to halt: electric charges cannot bridge the gap in the cut wire, and liquid cannot pass through the blinded pipe ends. Since there is only one path for movement in either circuit, the cessation of flow at one point rapidly halts flow at *all* points in these circuits. For the electric circuit this means both motors turn off. For the hydraulic circuit this means both turbines stop spinning.

In fact, the effect of an open *anywhere* in a simple (one-path) circuit is to rapidly halt current everywhere, because a continuous flow requires a complete loop²⁰. If current is prohibited by the open, then charges cannot move from a point of high energy to a point of low energy, and therefore are unable to release their energy from the circuit to do work (e.g. mechanical force and motion at the motors; turning turbines). Voltage will still be present in the electric circuit, across the terminals of the battery, because the chemical reactions in the battery are still elevating the energy states of the electric charges within. Likewise, “head” is still being produced by the spinning pump even though the liquid can no longer exit the pump and flow through the pipe: a pressure gauge attached to the discharge port of the pump will still show significant liquid pressure with the blinds in place.

¹⁹The severed wire now has an air gap separating the formerly connected ends. Air, as you may recall, is an electrical insulator at standard temperature because there are no charge carriers available to support an electric current: the electrons in the air molecules are tightly bound to their constituent atoms. An alternative to cutting the wire is to install a switch at that location in the circuit, allowing one to open the circuit on demand.

²⁰While it is possible for a *momentary* current to exist without a continuous path in which to circulate (e.g. lightning is a good example of this, with tremendous currents existing for brief periods of time as electric charges rush to re-balance their numbers between clouds and the Earth or from cloud to cloud), a *continuous* current requires an unbroken loop to support that circulation. This is a consequence of the *Law of Electric Charge Conservation*.

A less intuitive effect of the open is that points C, E, and D become equipotential to each other²¹. With no flow moving through those points, there will be no energy extracted from the circuit between those points, and therefore no voltage (or head) between them. Since points A and D were already equipotential, it means points C, E, D, and A are now all equipotential.

Now let us consider the effects of a “short” on circuits, both electric and hydraulic. In the electric circuit, the “short” is a piece of metal wire joining the two terminals of the upper motor together²²; in the hydraulic circuit, the “short” is a pipe bypassing the upper turbine:

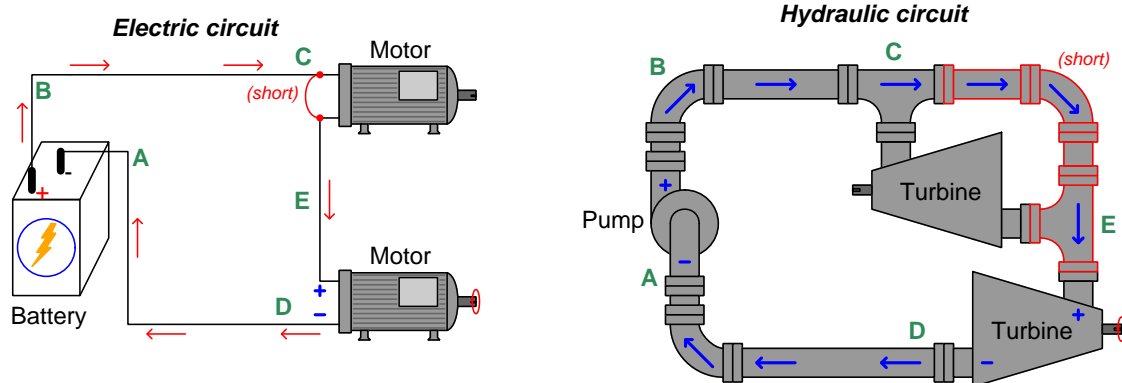

In either case, the “short” makes the connected points electrically common to one another, forcing their charge carriers to be at the same energy level. In this case we have connected points C and E together by the shorting wire (or pipe). This is why neither the upper motor nor the upper turbine spins. With those points being made equipotential, no energy is released by the flow going from one point to the other. The flow retains all its energy from point C and carries it to point E, ready to be put to work elsewhere. With the shorting “jumper wire” in place, the entire voltage of the battery is now impressed upon the lower motor, and the entire head of the pump is now impressed upon the lower turbine. The effect of this bypass is that both the lower motor and the lower turbine will spin faster than they did before the “short” was placed in each circuit.

²¹Here is a case where points may be equipotential to each other without being electrically *common* (i.e. directly connected by wire). Equipotentiality simply means a lack of potential difference between different points. Electrical commonality means different points connected together by a conductor of negligible resistance. A condition of electrical commonality forces those connected points to be equipotential to each other, but it is possible for points to be equipotential without being *directly* connected together.

²²Alternatively, we could have installed a switch at that location to short past the upper motor on demand, rather than attach a temporary wire.

4.9 Switches

Switches may be installed in wiring of the electric circuit to create these conditions on demand. Similarly, *valves* may be installed in the piping of the hydraulic circuit to control the flow. Consider the following example diagram, showing a single switch installed in the electric circuit and a single valve installed in the hydraulic circuit:

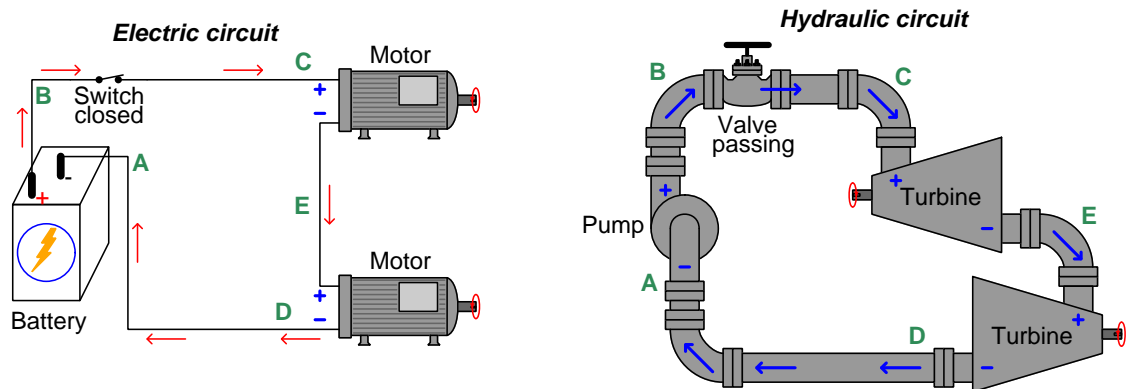

With the switch and valve in their “shorted” states, both circuits are functioning to transfer energy. However, when the switch and valve are blocking²³, flow ceases in each circuit and so does energy transfer:

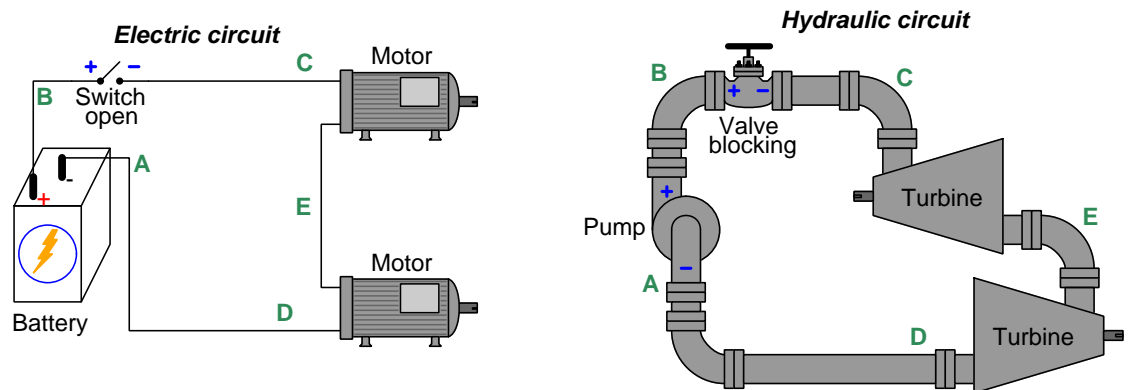

²³Valve state is usually described by the terms “open” and “shut” which can be confusing when contrasting with electrical switches because the term “open” for a valve is equivalent to the term “shorted” for a switch, while a “shut” valve is equivalent to an “open” switch. As you can see, the term “open” means exactly the opposite condition referring to a valve versus referring to a switch. Here I intentionally use the word “blocking” to avoid this confusion.

Chapter 5

Historical References

This chapter is where you will find references to historical texts and technologies related to the module's topic.

Readers may wonder why historical references might be included in any modern lesson on a subject. Why dwell on old ideas and obsolete technologies? One answer to this question is that the initial discoveries and early applications of scientific principles typically present those principles in forms that are unusually easy to grasp. Anyone who first discovers a new principle must necessarily do so from a perspective of ignorance (i.e. if you truly *discover* something yourself, it means you must have come to that discovery with no prior knowledge of it and no hints from others knowledgeable in it), and in so doing the discoverer lacks any hindsight or advantage that might have otherwise come from a more advanced perspective. Thus, discoverers are forced to think and express themselves in less-advanced terms, and this often makes their explanations more readily accessible to others who, like the discoverer, comes to this idea with no prior knowledge. Furthermore, early discoverers often faced the daunting challenge of explaining their new and complex ideas to a naturally skeptical scientific community, and this pressure incentivized clear and compelling communication. As James Clerk Maxwell eloquently stated in the Preface to his book *A Treatise on Electricity and Magnetism* written in 1873,

It is of great advantage to the student of any subject to read the original memoirs on that subject, for science is always most completely assimilated when it is in its nascent state . . . [page xi]

Furthermore, grasping the historical context of technological discoveries is important for understanding how science intersects with culture and civilization, which is ever important because new discoveries and new applications of existing discoveries will always continue to impact our lives. One will often find themselves impressed by the ingenuity of previous generations, and by the high degree of refinement to which now-obsolete technologies were once raised. There is much to learn and much inspiration to be drawn from the technological past, and to the inquisitive mind these historical references are treasures waiting to be (re)-discovered.

5.1 Benjamin Franklin on the nature of electricity

Early American statesman Benjamin Franklin was also a researcher on the then-mysterious subject of electricity. His famous kite experiment is described here, from his book *Experiments and Observations on Electricity, made at Philadelphia in America*, published in 1769. From letter XI (pages 111 through 112 of the book) dated 19 October 1752:

As frequent mention is made in public papers from *Europe* of the success of the *Philadelphia* experiment for drawing the electric fire from clouds by means of pointed rods of iron erected on high buildings, etc. it may be agreeable to the curious to be informed that the same experiment has succeeded in *Philadelphia*, though made in a different and more easy manner, which is as follows:

Make a small cross of two light strips of cedar, the arms so long as to reach the four corners of a large thin silk handkerchief when extended; tie the corners of the handkerchief to the extremities of the cross, so you have the body of a kite ; which being properly accommodated with a tail, loop, and string, will rise in the air, like those made of paper ; but this being of silk, is fitter to bear the wet and wind of a thunder-gust without tearing. To the top of the upright stick of the cross is to be fixed a very sharp pointed wire, rising a foot or more [page 111]

above the wood. To the end of the twine, next the hand, is to be tied a silk ribbon, and where the silk and twine join, a key may be fastened. This kite is to be raised when a thunder gust appears to be coming on, and the person who holds the string must stand within a door or window, or under some cover, so that the silk ribbon may not be wet ; and care must be taken that the twine does not touch the frame of the door or window. As soon as any of the thunder clouds come over the kite, the pointed wire will draw the electric fire from them, and the kite, with all the twine, will be electrified, and the loose filaments of the twine will stand out every way, and be attracted by an approaching finger. And when the rain has wet the kite and twine, so that it can conduct the electric fire freely, you will find it stream out plentifully from the key on the approach of your knuckle. At this key the phial may be charged ; and from the electric fire this obtained, spirits may be kindled, and all the other electric experiments be performed, which are usually done by the help of a rubbed glass globe or tube, and thereby the sameness of the electric matter with that of lightning completely demonstrated.

B.F. [page 112]

In the same book Franklin also provides an excellent comparison between conductors and insulators:

Query. Wherein consists the difference between an *electric* and a *non-electric* body?

Answer. The terms *electric per se*, and *non-electric* were first used to distinguish bodies, on a mistaken supposition that those called *electrics per se*, alone contained electric matter in their substance, which was capable of being excited by friction, and of being produced or drawn from them, and communicated to those called *non-electrics*, supposed to be destitute of it: For the glass, etc. being rubbed, discover'd signs of having it, by snapping to the finger, attracting, repelling, etc. and could communicate those signs to metals and water. – Afterwards it was found, that rubbing of glass would not produce the electric matter, unless a communication was preserved between the rubber and the floor ; and subsequent experiments proved that the electric matter was really drawn from those bodies that at first were thought to have none in them. Then it was doubted whether glass and other bodies called *electrics per se*, had really any electric matter in them, since they apparently afforded none but what they first extracted from those which had been called *non-electrics*. But some of my experiments shew that glass contains it in great quantity, and I now suspect it to be pretty equally diffused in all the matter of this terraqueous [page 95]

globe. If so, the terms *electric per se*, and *non-electric* should be laid aside as improper: And (the only difference being this, that some bodies will conduct electric matter, and others will not) the terms *conductor* and *non-conductor* may supply their place. If any portion of electric matter is applied to a piece of conducting matter, it penetrates and flows through it, or spreads equally on its surface ; if applied to a piece of non-conducting matter, it will do neither. Perfect conductors of electric matter are only metals and water. Other bodies conducting only as they contain a mixture of those ; without more or less of which they will not conduct at all¹. This (by the way) shews a new relation between metals and water heretofore unknown.

To illustrate this by a comparison, which, however, can only give a faint resemblance. Electric matter passes through conductors as water passes through a porous stone, or spreads on their surfaces as water spreads on a wet stone ; but when applied to non-conductors, it is like water dropt on a greasy stone, it neither penetrates, passes through, nor spreads on the surface, but remains in drops where it falls. See farther on this head in my last printed piece. [page 96]

¹Footnote from Franklin's text: This proposition is since found to be too general ; Mr Wilson having discovered that melted wax and rosin will also conduct.

One of the errors made by early experimenters of electricity was the determination of positive and negative charge, positive so-called because it was supposed to represent a surplus of the electric fluid and negative so-called because it represented a deficiency. We now know *electrons* are the majority electric charge carriers in most substances, and flow in the direction opposite to that which these early experimenters supposed, which is why today we call electrons *negatively charged particles*. This misconception, which early experimenters really had no way of correcting, remains to this day, and is often a source of confusion for students of electricity: the conventions of voltage polarity and current direction (“conventional flow” notation) make sense to us in terms of energy transfer for sources and loads, but in real metallic circuits the charge carriers are actually electrons moving in the other direction (i.e. “electron flow” notation).

One of Franklin’s correspondences contained in this same book (Letter X, dated 16 March 1752 and addressed to a Mr. E. Kinnersley living in Boston) explains his own assumptions on the matter:

Sir, Having brought your brimstone globe to work, I tried one of the experiments you proposed, and was agreeably surprised to find that the glass globe being at one end of the conductor, and the sulphur globe at the other end, both globes in motion, no spark could be obtained from the conductor, unless when one globe turned slower, or was not in so good order as the other ; and then the spark was only in proportion to the difference, so that turning equally, or turning that slowest which worked best, would again bring the conductor to afford no spark.

I found also, that the wire of a phial charg’d by the glass globe, attracted a cork ball that had touch’d the wire of a phial charged by the brimstone globe, and *vice versa*, [page 103]

so that the cork continued to play between the two phials, just as when one phial was charged through the wire, the other through the coating, by the glass globe alone. And two phials charged, the one by the brimstone globe, the other by the glass globe, would be both discharged by bringing their wires together, and shock the person holding the phials.

From these experiments one may be certain that your 2d, 3d, and 4th proposed experiments, would succeed exactly as you suppose, though I have not tried them, wanting time. – I imagine it is the glass globe that charges positively, and the sulphur negatively, for these reasons, 1. Though the sulfur globe seems to work equally well with the glass one, yet it can never be occasion to large and distant a spark between my knuckle and the conductor when the sulfur is working, as when the glass one is used ; which, I suppose, is occasioned by this, that bodies of a certain bigness cannot so easily part with a quantity or electrical fluid they have and hold attracted *within* their substance, as they can receive an additional quantity *upon* their surface by way of atmosphere. Therefore so much cannot be drawn *out* of the conductor, as can be thrown *on* it. 2. I observe that the stream or brush of fire, appearing at the end of a wires, connected with the conductor, is long, large, and much diverging, when the glass globe is used, and makes a snapping (or rattling) noise ; but when the sulphur one is used, it is short, small, and makes a hissing noise ; and just the re- [page 104]

verse of both happens, when you hold the same wire in your hand, and the globes are worked alternately : the brush is long, large, and diverging and snapping (or rattling) when the sulphur globe is turn’d ; short, small, and hissing when the glass globe is turn’d.

– When the brush is long, large, and much diverging, the body to which it joins, seems to be to be throwing the fire out ; and when the contrary appears, it seems to be drinking in. 3. I observe, that when I hold my knuckle before the sulphur globe, when turning, the stream of fire between my knuckle and the globe, seems to spread on its surface, as if it flowed from the finger ; on the glass globe it is otherwise. 4. The cool wind (or what was called so) that we used to feel as coming from an electrified point, is, I think, more sensible when the glass globe is used, than when the sulphur one. – But these are hasty thoughts. [page 105]

Another reason for his conjecture on polarity is given on page 9 of this same book (Letter II dated 11 July 1747 to Peter Collinson, Esquire, living in London):

. . . As we daily in our experiments [sic] electrify bodies *plus* or *minus*, as we think proper. – To electrify *plus* or *minus*, no more needs to be known that this, that the parts of the tube or sphere that are rubbed, do, in the instant of the friction, attract the electrical fire, and therefore take it from the thing rubbing: the same parts immediately, as the friction upon them ceases, are disposed to give the fire they have received, to any body that has less. [page 9]

It is worth noting that Franklin’s qualification stated on page 105 about his conclusions being “hasty thoughts” is not only characteristic of Franklin’s humility, but also a good example of proper scientific thinking. Good science always qualifies conclusions with estimates of uncertainty, because the limits of human perception and imagination always cast some shadow of doubt upon our own conclusions. In other words, the plain and incontrovertible fact that we as human beings commit errors means we must maintain a certain attitude of humility regarding any new conclusions we draw.

One interesting point to note is in reference to Franklin’s fourth reason (stated on page 105) for polarity of the glass globe. He writes of a “cool wind” emanating from an electrified point, which seemed to suggest to him a direction of current. We do know that a sensible flow of air molecules may be produced by static electricity, owing to the forced ionization of those air molecules (by either adding extra electrons to them or stripping electrons from them) and the subsequent repulsion of those electrically-charged molecules from the metallic point of charging. However, without knowing the polarity of those air molecules’ electric charge it is impossible to infer polarity from the direction of that “cool wind”. For the sake of argument, Franklin could have been feeling a breeze of positively-charged air molecules repelled by a positively-charged glass globe. In other words, it is quite possible that Franklin experienced an actual current of positive charge carriers when he concluded the glass globe was positively charged, even though the mobile charge carriers in a metal wire are negatively-charged electrons and not positively-charged air ions.

In Franklin’s defense, neither he nor any of his contemporaries would have been able to determine absolute polarity of charge given their primitive experimental apparatus and their lack of knowledge about atomic structure. However, in order to speak of electricity as being a *fluid* which is a surprisingly accurate description, some declaration regarding direction of flow was necessary in order to complete the analogy. They made their conjecture, and it proved to be wrong for charge carrier motion in metals, which is why to this day we have two contradicting models of current in electric circuits: *electron flow notation* and *conventional flow notation*.

5.2 James Clerk Maxwell on charge, potential, and electrical energy

Another famous investigator of electricity was the Scottish physicist James Clerk Maxwell (1831-1879) who presented a unified theory of electricity and magnetism in the form of five mathematical equations relating electric charge (Q), electric current (I), electric field (E), magnetic field (B), permittivity (ϵ), permeability (μ), as well as physical parameters such as area (A) and length (l). Maxwell's equations will not be presented here, as they are all based on calculus and extend far beyond the scope of this module.

In Maxwell's book *A Treatise on Electricity and Magnetism* (published in 1904) he explains how the quantity of electrical charge and the potential exhibited by charges combine to represent energy in an electrified system, much the same as other physical quantities such as *force* and *distance* combine to equal energy:

There is, however, another reason which warrants us in asserting that electricity, as a physical quantity, synonymous with the total electrification of a body, is not, like heat, a form of energy. An electrified system has a certain amount of energy, and this energy can be calculated by multiplying the quantity of electricity in each of its parts by another physical quantity, called the Potential of that part, and taking half the sum of the products. The quantities 'Electricity' and 'Potential,' when multiplied together, produce the quantity 'Energy.' It is impossible, therefore, that electricity and energy should be quantities of the same category, for electricity is only one of the factors of energy, the other factor being 'Potential.'

Energy, which is the product of these factors, may also be considered as the product of several other pairs of factors, such as

A Force \times A distance through which the force is to act.

A Mass \times Gravitation acting through a certain height.

A Mass \times Half the square of its velocity.

A Pressure \times A volume of fluid introduced into a vessel at that pressure.

A Chemical Affinity \times A chemical change, measured by the number of electro-chemical equivalents which enter into combination.

If we ever should obtain distinct mechanical ideas of the nature of electric potential, we may combine these with the idea of energy to determine the physical category in which 'Electricity' is to be placed. [page 39]

Here, Maxwell is saying that energy (measured in Joules) is the product of electric charge ("quantity of electricity" measured in Coulombs) and potential (voltage, measured in Volts, which is equivalent to Joules per Coulomb). This may be shown dimensionally as follows:

$$[\text{Joules}] = [\text{Coulombs}] \times \frac{[\text{Joules}]}{[\text{Coulomb}]}$$

5.3 James Clerk Maxwell on the nature of electric potential

From the same book (*A Treatise on Electricity and Magnetism*), James Clerk Maxwell defines electric potential in terms of work done (i.e. energy transferred) moving an electric charge:

Definition of Potential. The Potential at a Point is the work which would be done on a unit of positive electricity by the electric forces if it were placed at that point without disturbing the electric distribution, and carried from that point to an infinite distance: or, what comes to the same thing, that work which must be done by an external agent in order to bring the unit of positive electricity from an infinite distance (or from any place where the potential is zero) to the given point. [page 78]

This is the closest we can come to defining electric potential as an absolute quantity at a single point: the amount of energy either gained or lost by a test charge moved an infinite distance toward or away from some other electrical charge(s). This definition of absolute potential is impractical², and so we must instead define voltage as the *potential difference* between two points. By analogy, defining electric potential in terms of infinite distance is like defining potential energy for a mass on Earth as the amount of work necessary to lift that mass away from Earth to some infinite distance³.

On the next page, Maxwell discusses how electric charges tend to move in such a way as to minimize their potential, and how analogies to fluid and heat, while helpful, should never be taken too literally:

Potential, in electrical science, has the same relation to Electricity that Pressure, in Hydrostatics, has to Fluid, or that Temperature, in Thermodynamics, has to Heat. Electricity, Fluids, and Heat all tend to pass from one place to another, if the Potential, Pressure, or Temperature is greater in the first place than in the second. A fluid is certainly a substance, heat is as certainly not a substance, so that though we may find assistance from analogies of this kind in forming clear ideas of formal relations of electrical quantities, we must be careful not to let that one or the other analogy suggest to us that electricity is either a substance like water, or a state of agitation like heat. [page 79]

²The first and most obvious reason this definition of potential is impractical is that we cannot perform a real experiment where a test charge gets moved *an infinite distance away* from another charge. However, one could argue that such a thing could be simulated mathematically, and that is good enough for a fundamental definition; furthermore, that one can move a test charge over finite distances and empirically show that the potential energy required *approaches* the theoretical value over an infinite distance. However, there is another reason why it is impossible to actually define potential at any single location, and that is because the procedure assumes the test charge and the reference charge are *the only two electrical charges existing in the entire universe*. If one considers the existence of any other charges existing anywhere else in space, then the potential of that test charge could just as easily be defined in terms of the distance from *any one* of those other charges. Another way of saying this is that *potential can only have an absolute definition if just one point of reference exists*. Otherwise, our test charge can be said to have as many different values of potential as there are reference charges elsewhere in the universe!

³This, in fact, is how *escape velocity* is defined for any planet: the velocity at which a mass at ground level would have to travel in an upward direction in order to escape that planet's gravitational field – i.e. the velocity resulting in an amount of kinetic energy equal to the potential energy necessary to shoot that mass away from the planet so that it never returns. Here again we see how potential energy must be a relative quantity rather than absolute: escape velocity is always relative to a particular planet, such that the escape velocity for any mass depends entirely on which planet you propose escaping from.

5.4 John Ambrose Fleming on the nature of electric potential

What follows is a selection from John Ambrose Fleming's text *Electric Lamps and Electric Lighting* published in 1894, discussing electric potential:

We pass next to consider another important matter, viz., that of electric pressure or potential; and we shall be helped in grasping this idea by considering the corresponding conception in the case of the flow of fluids. When a fluid such as water flows along a pipe it does so in virtue of the fact that there is a difference of pressure between different points in the pipes, and the water flows in the pipe from the place where the pressure is greatest to the place where the pressure is least. On the table before you is a horizontal pipe (Fig. 5) which is connected with a cistern of water, and which delivers water to another receptacle at a lower level. In that pipe are placed a number of vertical glass tubes to enable us to measure the pressure in the pipe at any instant. The pressure at the foot of each gauge glass is exactly measured by the *head* or elevation of the water in the vertical gauge glass, and at the present moment, when the outlet from the horizontal pipe is closed, you will notice that the water in all the gauge glasses stands up to the same height as the water in the cistern. In other words, the pressure in the pipe is everywhere the same. [page 11]

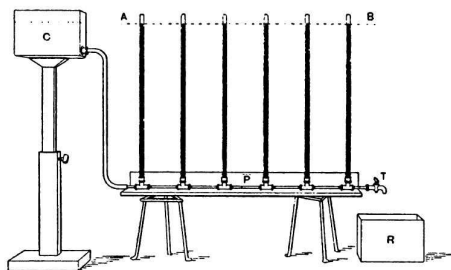

FIG. 5.—Horizontal pipe P, having six vertical gauge tubes attached to it. The pipe P is in connection with a water cistern C, and when the tap T is shut the water stands up at the same level, A B, in all the tubes.

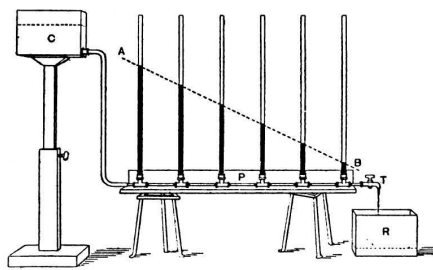

FIG. 6.—Horizontal pipe P, through which water is flowing from a cistern C to a reservoir R. When the tap T is open the water stands at gradually decreasing heights in the pressure tubes. The dotted line A B shows the hydraulic gradient.

Opening the outlet tap we allow the water to flow out from the pipe, and you will then observe that the water sinks (see Fig. 6) in each gauge glass, and, so far from being now uniform in height, there is seen to be a regular fall in pressure along the pipe, the gauge glass nearest the cistern showing the greatest pressure, the next one less, the next one less still, and so on, the pressure in the horizontal pipe gradually diminishing as we proceed along towards the tap by which the water is flowing out. This fall in pressure along the pipe takes place in every gas and water pipe, and is called the hydraulic gradient in the pipe. The flow of water takes place in virtue of this gradient of pressure. It will be next necessary to explain to you that there is an exactly similar phenomenon in the case of an electric current in a wire, and that there is a quantity which we may call the *electric pressure*, which diminishes in amount as we proceed along the wire when the current is flowing in it. [page 12]

The fall in electric potential along a current-carrying wire, like the fall of pressure in a pipe carrying a flow of liquid, is due to *resistance* along the flowing path. In a practical circuit where we

do not wish energy to be dissipated along wires but only at the intended load(s), the fall of potential (i.e. “voltage drop”) along any current-carrying conductor is rather small, and is assumed to be negligible for most practical purposes.

5.5 James Prescott Joule on the conservation of energy

The following text comes from a lecture given by James Prescott Joule in 1847 at the reading-room of Saint Ann’s Church, entitled *On Matter, Living Force, and Heat*. In this lecture Joule outlines a general theme of energy conservation, being one of the pivotal discoveries within the field of thermodynamics. The modern reader should note that in Joule’s time the terms *potential* and *kinetic* energy did not yet exist in common scientific dialogue, and so we find Joule using the term *living force* to describe what we now call kinetic energy: the energy possessed by a mass by virtue of its motion. Joule describes three forms of energy (*heat, living force, and attraction through space*), which we would in modern terms describe as *thermal energy*⁴, *kinetic energy*, and *potential energy*, respectively.

This lecture is remarkable for several reasons. First, it clearly and compellingly describes a range of physics principles in language suitable for a non-technical audience: matter, gravity, inertia, kinetic energy, energy transfer, potential energy, the permanence (i.e. conservation) of energy, the equivalence of different forms of energy to each other, meteorological phenomena, sensible and latent heat, phase changes, conductive heat transfer, and even a hint at the energy involved in chemical reactions. Second, it strives (and succeeds, in my opinion) to show how energy may be used as a unifying principle linking seemingly unrelated concepts. Third, it concludes with an encouragement to the audience that a study of physics from the perspective of energy is a profitable approach for learning. I have certainly found this to be true when educating students on the mysteries of electric circuits, that *energy* proves an extremely useful perspective for understanding. To quote Joule himself, “patient inquiry on these grounds can hardly fail to be amply rewarded.”

Without further adieu, I give you the lecture of James Prescott Joule:

ON MATTER, LIVING FORCE, AND HEAT (1847)

In our notion of matter two ideas are generally included, namely those of *impenetrability* and *extension*. By the extension of matter we mean the space which it occupies; by its impenetrability we mean that two bodies cannot exist at the same time in the same place. Impenetrability and extension cannot with much propriety be reckoned among the *properties* of matter, but deserve rather to be called its *definitions*, because nothing that does not possess the two qualities bears the name of matter. If we conceive of impenetrability and extension we have the idea of matter, and of matter only.

Matter is endowed with an exceedingly great variety of wonderful properties, some of which are common to all matter, while others are present variously, so as to constitute a difference between one body and another. Of the first of these classes, the attraction of gravitation is one of the most important. We observe its presence readily in all solid bodies, the component parts of which are, in the opinion⁵ of Majocchi, held together by this force. If we break the body in pieces, and remove the separate pieces to a distance from each other, they will still be found to attract each other, though in a very slight

⁴Later in his lecture, Joule hypothesizes that heat is really just another form of mechanical energy, be it living force (kinetic energy) in the case of sensible heat, or attraction through space (potential energy) in the case of latent heat.

⁵Note: Majocchi was incorrect in this hypothesis. We now know forces other than just gravity work to bind particles together to form solid bodies. The more general point, however, is still sound: any force acting to attract masses to one another is capable of imparting potential energy to matter – “attraction through space” in Joule’s parlance.

degree, owing to the force being one which diminishes very rapidly as the bodies are removed further from one another. The larger the bodies are the more powerful is the force of attraction subsisting between them. Hence, although the force of attraction between small bodies can only be appreciated by the most delicate apparatus except in the case of contact, that which is occasioned by a body of immense magnitude, such as the earth, becomes very considerable. This attraction of bodies towards the earth constitutes what is called their weight or gravity, and is always exactly proportional to the quantity of matter. Hence, if any body be found to weigh 2 lb., while another only weighs 1 lb., the former will contain exactly twice as much matter as the latter; and this is the case, whatever the bulk of the bodies may be: 2-lb. weight of air contains exactly twice the quantity of matter that lib. of lead does.

Matter is sometimes endowed with other kinds of attraction besides the attraction of gravitation; sometimes also it possesses the faculty of *repulsion*, by which force the particles tend to separate further from each other. Wherever these forces exist, they do not supersede the attraction of gravitation. Thus the weight of a piece of iron or steel is in no way affected by imparting to it the magnetic virtue.

Besides the force of gravitation, there is another very remarkable property displayed in an equal degree by every kind of matter – its perseverance in any condition, whether of rest or motion, in which it may have been placed. This faculty has received the name of *inertia*, signifying passiveness, or the inability of any thing to change its own state. It is in consequence of this property that a body at rest cannot be set in motion without the application of a certain amount of force to it, and also that when once the body has been set in motion it will never stop of itself, but continue to move straight forwards with a uniform velocity until acted upon by another force, which, if applied contrary to the direction of motion, will retard it, if in the same direction will accelerate it, and if sideways will cause it to move in a curved direction. In the case in which the force is applied contrary in direction, but equal in degree to that which set the body first in motion, it will be entirely deprived of motion whatever time may have elapsed since the first impulse, and to whatever distance the body may have travelled.

From these facts it is obvious that the force expended in setting a body in motion is carried by the body itself, and exists with it and in it, throughout the whole course of its motion. This force possessed by moving bodies is termed by mechanical philosophers *vis viva*, or *living force*. The term may be deemed by some inappropriate, inasmuch as there is no life, properly speaking, in question; but it is useful in order to distinguish the moving force from that which is stationary in its character, as the force of gravity. When, therefore, in the subsequent parts of this lecture I employ the term *living force*, you will understand that I simply mean the force of bodies in motion. The living force of bodies is regulated by their weight and by the velocity of their motion. You will readily understand that if a body of a certain weight possess a certain quantity of living force, twice as much living force will be possessed by a body of twice the weight, provided both bodies move with equal velocity. But the law by which the velocity of a body regulates its living force is not so obvious. At first sight one would imagine that the living force would be simply proportional to the velocity, so that if a body moved twice as fast as another, it would have twice the impetus or living force. Such, however, is not the case;

for if three bodies of equal weight move with the respective velocities of 1, 2, and 3 miles per hour, their living forces will be found to be proportional to those numbers multiplied by themselves, *viz.* to 1×1 , 2×2 , 3×3 , or 1, 4, and 9, the squares of 1, 2, and 3. This remarkable law may be proved in several ways. A bullet fired from a gun at a certain velocity will pierce a block of wood to only one quarter of the depth it would if propelled at twice the velocity. Again, if a cannon-ball were found to fly at a certain velocity when propelled by a given charge of gun-powder, and it were required to load the cannon so as to propel the ball with twice that velocity, it would be found necessary to employ four times the weight of powder previously used. Thus, also, it will be found that a railway-train going at 70 miles per hour possesses 100 times the impetus, or living force, that it does when travelling at 7 miles per hour.

A body may be endowed with living force in several ways. It may receive it by the impact of another body. Thus, if a perfectly elastic ball be made to strike another similar ball of equal weight at rest, the striking ball will communicate the whole of its living force to the ball struck, and, remaining at rest itself, will cause the other ball to move in the same direction and with the same velocity that it did itself before the collision. Here we see an instance of the facility with which living force may be transferred from one body to another. A body may also be endowed with living force by means of the action of gravitation upon it through a certain distance. If I hold a ball at a certain height and drop it, it will have acquired when it arrives at the ground a degree of living force proportional to its weight and the height from which it has fallen. We see, then, that living force may be produced by the action of gravity through a given distance or space. We may, therefore, say that the former is of equal value, or *equivalent*, to the latter. Hence, if I raise a weight of 1 lb. to the height of one foot, so that gravity may act on it through that distance, I shall communicate to it that which is of equal value or equivalent to a certain amount of living force; if I raise the weight to twice the height, I shall communicate to it the equivalent of twice the quantity of living force. Hence, also, when we compress a spring, we communicate to it the equivalent to a certain amount of living force; for in that case we produce molecular attraction between the particles of the spring through the distance they are forced asunder, which is strictly analogous to the production of the attraction of gravitation through a certain distance.

You will at once perceive that the living force of which we have been speaking is one of the most important qualities with which matter can be endowed, and, as such, that it would be absurd to suppose that it can be destroyed, or even lessened, without producing the equivalent of attraction through a given distance of which we have been speaking. You will therefore be surprised to hear that until very recently the universal opinion has been that living force could be absolutely and irrevocably destroyed at anyone's option. Thus, when a weight falls to the ground, it has been generally supposed that its living force is absolutely annihilated, and that the labour which may have been expended in raising it to the elevation from which it fell has been entirely thrown away and wasted without the production of any permanent effect whatever. We might reason, *a priori*, that such absolute destruction of living force cannot possibly take place, because it is manifestly absurd to suppose that the powers with which God has endowed matter can be destroyed any more than that they can be created by man's agency; but we are not

left with this argument alone, decisive as it must be to every unprejudiced mind. The common experience of every one teaches him that living force is not *destroyed* by the friction or collision of bodies. We have reason to believe that the manifestations of living force on our globe are, at the present time, as extensive as those which have existed at any time since its creation, or, at any rate, since the deluge – that the winds blow as strongly, and the torrents flow with equal impetuosity now, as at the remote period of 4000 or even 6000 years ago; and yet we are certain that, through that vast interval of time, the motions of the air and of the water have been incessantly obstructed and hindered by friction. We may conclude, then, with certainty, that these motions of air and water, constituting living force, are not *annihilated* by friction. We lose sight of them, indeed, for a time; but we find them again reproduced. Were it not so, it is perfectly obvious that long ere this all nature would have come to a dead standstill. What, then, may we inquire, is the cause of this apparent anomaly? How comes it to pass that, though in almost all natural phenomena we witness the arrest of motion and the apparent destruction of living force, we find that no waste or loss of living force has actually occurred? Experiment has enabled us to answer these questions in a satisfactory manner; for it has shown that, wherever living force is *apparently* destroyed, an equivalent is produced which in process of time may be reconverted into living force. This equivalent is *heat*. Experiment has shown that wherever living force is apparently destroyed or absorbed, heat is produced. The most frequent way in which living force is thus converted into heat is by means of friction. Wood rubbed against wood or against any hard body, metal rubbed against metal or against any other body – in short, all bodies, solid or even liquid, rubbed against each other are invariably heated, sometimes even so far as to become red-hot. In all these instances the quantity of heat produced is invariably in proportion to the exertion employed in rubbing the bodies together – that is, to the living force absorbed. By fifteen or twenty smart and quick strokes of a hammer on the end of an iron rod of about a quarter of an inch in diameter placed upon an anvil an expert blacksmith will render that end of the iron visibly red-hot. Here heat is produced by the absorption of the living force of the descending hammer in the soft iron; which is proved to be the case from the fact that the iron cannot be heated if it be rendered hard and elastic, so as to transfer the living force of the hammer to the anvil.

The general rule, then, is, that wherever living force is *apparently* destroyed, whether by percussion, friction, or any similar means, an exact equivalent of heat is restored. The converse of this proposition is also true, namely, that heat cannot be lessened or absorbed without the production of living force, or its equivalent attraction through space. Thus, for instance, in the steam-engine it will be found that the power gained is at the expense of the heat of the fire – that is, that the heat occasioned by the combustion of the coal would have been greater had a part of it not been absorbed in producing and maintaining the living force of the machinery. It is right, however, to observe that this has not as yet been demonstrated by experiment. But there is no room to doubt that experiment would prove the correctness of what I have said; for I have myself proved that a conversion of heat into living force takes place in the expansion of air, which is analogous to the expansion of steam in the cylinder of the steam-engine. But the most convincing proof of the conversion of heat into living force has been derived from my experiments with the electro-magnetic engine, a machine composed of magnets and bars

of iron set in motion by an electrical battery. I have proved by actual experiment that, in exact proportion to the force with which this machine works, heat is abstracted from the electrical battery. You see, therefore, that living force may be converted into heat, and that heat may be converted into living force, or its equivalent attraction through space. All three, therefore – namely, heat, living force, and attraction through space (to which I might also add *light* were it consistent with the scope of the present lecture) – are mutually convertible into one another. In these conversions nothing is ever lost. The same quantity of heat will always be converted into the same quantity of living force. We can therefore express the equivalency in definite language applicable at all times and under all circumstances. Thus the attraction of 817 lb. through the space of one foot is equivalent to, and convertible into, the living force possessed by a body of the same weight of 817 lb. when moving with the velocity of eight feet per second, and this living force is again convertible into the quantity of heat which can increase the temperature of one pound of water by one degree Fahrenheit. The knowledge of the equivalency of heat to mechanical power is of great value in solving a great number of interesting and important questions. In the case of the steam-engine, by ascertaining the quantity of heat produced by the combustion of coal, we can find out how much of it is converted into mechanical power, and thus come to a conclusion how far the steam-engine is susceptible of further improvements. Calculations made upon this principle have shown that at least ten times as much power might be produced as is now obtained by the combustion of coal. Another interesting conclusion is, that the animal frame, though destined to fulfil so many other ends, is as a machine more perfect than the best contrived steam-engine – that is, is capable of more work with the same expenditure of fuel.

Behold, then, the wonderful arrangements of creation. The earth in its rapid motion round the sun possesses a degree of living force so vast that, if turned into the equivalent of heat, its temperature would be rendered at least 1000 times greater than that of red-hot iron, and the globe on which we tread would in all probability be rendered equal in brightness to the sun itself. And it cannot be doubted that if the course of the earth were changed so that it might fall into the sun, that body, so far from being cooled down by the contact of a comparatively cold body, would actually blaze more brightly than before in consequence of the living force with which the earth struck the sun being converted into its equivalent of heat. Here we see that our existence depends upon the *maintenance* of the living force of the earth. On the other hand, our safety equally depends in some instances upon the conversion of living force into heat. You have, no doubt, frequently observed what are called *shooting-stars*, as they appear to emerge from the dark sky of night, pursue a short and rapid course, burst, and are dissipated in shining fragments. From the velocity with which these bodies travel, there can be little doubt that they are small planets which, in the course of their revolution round the sun, are attracted and drawn to the earth. Reflect for a moment on the consequences which would ensue, if a hard meteoric stone were to strike the room in which we are assembled with a velocity sixty times as great as that of a cannon-ball. The dire effects of such a collision are effectually prevented by the atmosphere surrounding our globe, by which the velocity of the meteoric stone is checked and its living force converted into heat, which at last becomes so intense as to melt the body and dissipate it into fragments too small probably to be noticed in their fall to the ground. Hence it is that, although multitudes

of shooting-stars appear every night, few meteoric stones have been found, those few corroborating the truth of our hypothesis by the marks of intense heat which they bear on their surfaces.

Descending from the planetary space and firmament to the surface of our earth, we find a vast variety of phenomena connected with the conversion of living force and heat into one another, which speak in language which cannot be misunderstood of the wisdom and beneficence of the Great Architect of nature. The motion of air which we call *wind* arises chiefly from the intense heat of the torrid zone compared with the temperature of the temperate and frigid zones. Here we have an instance of heat being converted into the living force of currents of air. These currents of air, in their progress across the sea, lift up its waves and propel the ships; whilst in passing across the land they shake the trees and disturb every blade of grass. The waves by their violent motion, the ships by their passage through a resisting medium, and the trees by the rubbing of their branches together and the friction of their leaves against themselves and the air, each and all of them generate heat equivalent to the diminution of the living force of the air which they occasion. The heat thus restored may again contribute to raise fresh currents of air; and thus the phenomena may be repeated in endless succession and variety.

When we consider our own animal frames, “fearfully and wonderfully made,” we observe in the motion of our limbs a continual conversion of heat into living force, which may be either converted back again into heat or employed in producing an attraction through space, as when a man ascends a mountain. Indeed the phenomena of nature, whether mechanical, chemical, or vital, consist almost entirely in a continual conversion of attraction through space, living force, and heat into one another. Thus it is that order is maintained in the universe – nothing is deranged, nothing ever lost, but the entire machinery, complicated as it is, works smoothly and harmoniously. And though, as in the awful vision of Ezekiel, “wheel may be in the middle of wheel,” and every thing may appear complicated and involved in the apparent confusion and intricacy of an almost endless variety of causes, effects, conversions, and arrangements, yet is the most perfect regularity preserved – the whole being governed by the sovereign will of God.

A few words may be said, in conclusion, with respect to the real nature of heat. The most prevalent opinion, until of late, has been that it is a *substance* possessing, like all other matter, impenetrability and extension. We have, however, shown that heat can be converted into living force and into attraction through space. It is perfectly clear, therefore, that unless matter can be converted into attraction through space, which is too absurd an idea to be entertained for a moment, the hypothesis of heat being a substance must fall to the ground. Heat must therefore consist of either living force or of attraction through space. In the former case we can conceive the constituent particles of heated bodies to be, either in whole or in part, in a state of motion. In the latter we may suppose the particles to be removed by the process of heating, so as to exert attraction through greater space. I am inclined to believe that both of these hypotheses will be found to hold good – that in some instances, particularly in the case of *sensible* heat, or such as is indicated by the thermometer, heat will be found to consist in the living force of the particles of the bodies in which it is induced; whilst in others, particularly in the case of *latent* heat, the phenomena are produced by the separation of particle from particle,

so as to cause them to attract one another through a greater space. We may conceive, then, that the communication of heat to a body consists, in fact, in the communication of impetus, or living force, to its particles. It will perhaps appear to some of you something strange that a body apparently quiescent should in reality be the seat of motions of great rapidity; but you will observe that the bodies themselves, considered as wholes, are not supposed to be in motion. The constituent particles, or atoms of the bodies, are supposed to be in motion, without producing a gross motion of the whole mass. These particles, or atoms, being far too small to be seen even by the help of the most powerful microscopes, it is no wonder that we cannot observe their motion. There is therefore reason to suppose that the particles of all bodies, their constituent atoms, are in a state of motion almost too rapid for us to conceive, for the phenomena cannot be otherwise explained. The velocity of the atoms of water, for instance, is at least equal to a mile per second of time. If, as there is reason to think, some particles are at rest while others are in motion, the velocity of the latter will be proportionally greater. An increase of the velocity of revolution of the particles will constitute an increase of temperature, which may be distributed among the neighbouring bodies by what is called *conduction* – that is, on the present hypothesis, by the communication of the increased motion from the particles of one body to those of another. The velocity of the particles being further increased, they will tend to fly from each other in consequence of the centrifugal force overcoming the attraction subsisting between them. This removal of the particles from each other will constitute a new condition of the body – it will enter into the state of fusion, or become melted. But, from what we have already stated, you will perceive that, in order to remove the particles violently attracting one another asunder, the expenditure of a certain amount of living force or heat will be required. Hence it is that heat is always absorbed when the state of a body is changed from solid to liquid, or from liquid to gas. Take, for example, a block of ice cooled down to zero; apply heat to it, and it will gradually arrive at 32° , which is the number conventionally employed to represent the temperature at which ice begins to melt. If, when the ice has arrived at this temperature, you continue to apply heat to it, it will become melted; but its temperature will not increase beyond 32° until the whole has been converted into water. The explanation of these facts is clear on our hypothesis. Until the ice has arrived at the temperature of 32° the application of heat increases the velocity of rotation of its constituent particles; but the instant it arrives at that point, the velocity produces such an increase of the centrifugal force of the particles that they are compelled to separate from each other. It is in effecting this separation of particles strongly attracting one another that the heat applied is then spent; not in increasing the velocity of the particles. As soon, however, as the separation has been effected, and the fluid water produced, a further application of heat will cause a further increase of the velocity of the particles, constituting an increase of temperature, on which the thermometer will immediately rise above 32° . When the water has been raised to the temperature of 212° , or the boiling-point, a similar phenomenon will be repeated; for it will be found impossible to increase the temperature beyond that point, because the heat then applied is employed in separating the particles of water so as to form steam, and not in increasing their velocity and living force. When, again, by the application of cold we condense the steam into water, and by a further abstraction of heat we bring the water to the solid condition of ice, we witness the repetition of similar phenomena in the reverse order. The particles of steam, in assuming the condition of water, fall

together through a certain space. The living force thus produced becomes converted into heat, which must be removed before any more steam can be converted into water. Hence it is always necessary to abstract a great quantity of heat in order to convert steam into water, although the temperature will all the while remain exactly at 212°; but the instant that all the steam has been condensed, the further abstraction of heat will cause a diminution of temperature, since it can only be employed in diminishing the velocity of revolution of the atoms of water. What has been said with regard to the condensation of steam will apply equally well to the congelation of water.

I might proceed to apply the theory to the phenomena of combustion, the heat of which consists in the living force occasioned by the powerful attraction through space of the combustible for the oxygen, and to a variety of other thermo-chemical phenomena; but you will doubtless be able to pursue the subject further at your leisure. I do assure you that the principles which I have very imperfectly advocated this evening may be applied very extensively in [sic] elucidating many of the abstruse as well as the simple points of science, and that patient inquiry on these grounds can hardly fail to be amply rewarded.

Chapter 6

Derivations and Technical References

This chapter is where you will find mathematical derivations too detailed to include in the tutorial, and/or tables and other technical reference material.

6.1 Fluid pressure as an analogue of voltage

Early investigators of electricity likened this strange and new phenomenon to the motion of fluid, and in retrospect this analogy is appropriate for many reasons. We now know that electric current is indeed the motion of electrically-charged matter, whether it be electrons through the bulk of a solid metal, positively-charged and negatively-charged ions within a liquid solution, or positively-charged and negatively-charged ions within a gas. Just as fluids have the ability to possess and transport energy, so does electricity, and the relationship between electricity and energy constitutes one of the keystone principles explored throughout this tutorial series.

The concepts of *electrical potential* and of *voltage* also map well to the fluid analogy, particularly to the concept of fluid *pressure*. Here we will explore how energy is quantified for any fluid stream, and see how this is similar to electricity.

A fluid stream may possess energy in three different modes: *gravitational potential energy*, *pressure potential energy*, and *kinetic energy*. We know from the study of basic kinematics (physics) that gravitational potential energy for any mass elevated above the Earth is equal to:

$$E_p = mgh$$

Where,

E_p = Potential energy of object (Joules)

m = Mass of elevated object (kilograms)

g = Acceleration of gravity (meters per second squared)

h = Height above ground (meters)

Expressing potential energy in terms of the units of measurement used for all variables shows us that the unit of the Joule (for energy) is equivalent to kilograms times meters squared per second squared:

$$[\text{J}] = [\text{kg}] \left[\frac{\text{m}}{\text{s}^2} \right] [\text{m}] = [\text{kg}] \left[\frac{\text{m}^2}{\text{s}^2} \right]$$

We also know that the kinetic energy possessed by any moving mass is equal to:

$$E_k = \frac{1}{2}mv^2$$

Where,

E_k = Kinetic energy of object (Joules)

m = Mass of moving object (kilograms)

v = Velocity of moving object (meters per second)

Once again, analyzing the dimensions (units) of this formula reveals that the unit of the Joule is equivalent to a kilogram-meter squared per second squared:

$$[\text{J}] = [\text{kg}] \left[\frac{\text{m}}{\text{s}} \right]^2 = [\text{kg}] \left[\frac{\text{m}^2}{\text{s}^2} \right]$$

Any fluid, whether it be a gas or a liquid, is comprised of individual molecules, and so these formulae apply to those molecules individually since they may be elevated and/or moving. Instead of referring to the mass of an individual fluid molecule, however, it is more practical to refer to the *mass density* of the bulk fluid expressed as the amount of mass per unit volume of fluid. A common formula used in the field of fluid dynamics is *Bernoulli's Equation*¹ which expresses these forms of energy for any two locations within a frictionless fluid stream but also includes one more form: pressure.

$$z_1\rho g + \frac{v_1^2\rho}{2} + P_1 = z_2\rho g + \frac{v_2^2\rho}{2} + P_2$$

Where,

z = Height of fluid (from a common reference point, usually ground level)

ρ = Mass density of fluid (kilograms per cubic meter)

g = Acceleration of gravity (meters per second squared)

v = Velocity of fluid (meters per second)

P = Pressure of fluid (Newtons per square meter)

Each of the three terms in Bernoulli's equation expresses a relationship with energy, commonly referred to as *head*:

$z\rho g$ Elevation head

$\frac{v^2\rho}{2}$ Velocity head

P Pressure head

As you can see, the only real differences between the solid-object and fluid formulae for energies is the use of mass *density* (ρ) for fluids instead of mass (m) for solids, and the arbitrary use of the variable z for height instead of h . In essence, the elevation and velocity head terms within Bernoulli's equation come from the assumption of individual fluid molecules behaving as miniscule solid masses. "Head" is not identical to energy, but it is certainly related to energy.

The pressure term (P) is something novel to Bernoulli's Equation which has no clear counterpart to individual solid masses. In a fluid, *pressure* is the amount of force that fluid will exert upon a containing surface such as the wall of a tank, or a piston. Pressure is a function of fluid molecule collisions against that surface, imparting a force upon it. The fact that pressure is included as a term within the sum of Bernoulli's Equation tells us it must fundamentally be the same type of thing as elevation head and as velocity head, with the same (or equivalent) units of measurement.

¹This is named after Daniel Bernoulli, but was first formulated by the mathematician Leonhard Euler and popularized by Julius Weisbach.

Just as energy is conserved, *head* is conserved in any fluid system where the fluid does not dissipate any energy to a non-fluid form. Consider the following example, showing a liquid inside of an open vessel. At three different points in this vessel, liquid molecules will have different heights (z), different pressures (P), and different velocities (v). According to Bernoulli's Equation, so long as fluid molecules dissipate no energy moving between these points, the sum total of their heads must remain constant:

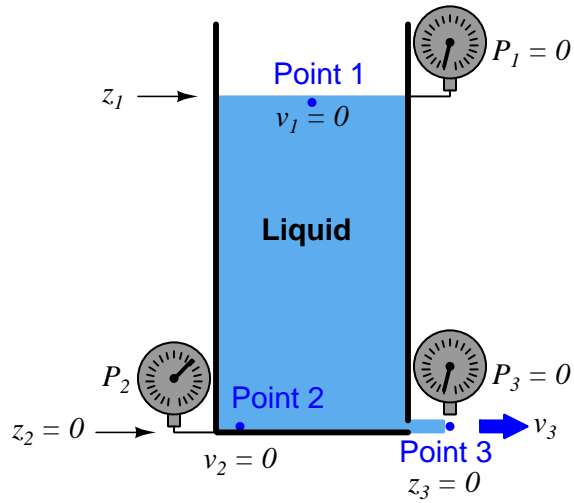

Examining this illustration, we see fluid located at point 1 has no motion and no pressure, but it does possess height (i.e. elevation head). Fluid at point 2 has no motion and no height, but it does possess pressure (pressure head). Fluid exiting the vessel at point 3 has no height and no pressure, but it does possess speed (velocity head). Again, assuming no energy is gained or lost along the way, a fluid molecule traveling from point 1 to point 2 will lose elevation but gain an equivalent amount of pressure; a fluid molecule moving from point 2 to point 3 will lose pressure but gain an equivalent amount of velocity; etc.

Let us now analyze the dimensions (i.e. units of measurement) used in the three terms of Bernoulli's Equation to verify that they are indeed equivalent:

$$z\rho g + \frac{\rho v^2}{2} + P$$

$$[\text{m}] \left[\frac{\text{kg}}{\text{m}^3} \right] \left[\frac{\text{m}}{\text{s}^2} \right] + \left[\frac{\text{kg}}{\text{m}^3} \right] \left[\frac{\text{m}}{\text{s}} \right]^2 + \left[\frac{\text{N}}{\text{m}^2} \right]$$

Canceling extra m terms proves the elevation head and velocity head terms to be equivalent:

$$\left[\frac{\text{kg}}{\text{m s}^2} \right] + \left[\frac{\text{kg}}{\text{m s}^2} \right] + \left[\frac{\text{N}}{\text{m}^2} \right]$$

Now for the pressure head term. One Newton of force is equivalent to a kilogram of mass accelerated one meter per second squared according to the formula $F = ma$. Therefore, $[\text{N}] = [\text{kg}][\text{m}/\text{s}^2]$. Substituting this for N in Bernoulli's Equation, we get the following:

$$\left[\frac{\text{kg}}{\text{m s}^2} \right] + \left[\frac{\text{kg}}{\text{m s}^2} \right] + \left[\frac{\text{kg}[\text{m}/\text{s}^2]}{\text{m}^2} \right]$$

Canceling m and simplifying the compound fraction in the last term yields the expected result:

$$\left[\frac{\text{kg}}{\text{m s}^2} \right] + \left[\frac{\text{kg}}{\text{m s}^2} \right] + \left[\frac{\text{kg}}{\text{m s}^2} \right]$$

It is now clear that all three “heads” in Bernoulli's Equation refer to the same physical quantity. But what is this quantity, exactly? We know that energy (Joules) is equivalent to kilograms times meters squared per second squared, but these are not the exact same units. Each of the “head” terms are kilograms per meter-second squared, not kilograms times meters squared per second squared.

The difference between these two sets of units is cubic meters. Observe as we take the units for energy and divide by cubic meters:

$$\left[\frac{\text{J}}{\text{m}^3} \right] = \frac{[\text{kg}] \left[\frac{\text{m}^2}{\text{s}^2} \right]}{\text{m}^3} = \left[\frac{\text{kg}}{\text{m s}^2} \right]$$

This proves that the units of measurement inherent to each of the three “head” terms in Bernoulli's Equation are equivalent to Joules of energy per cubic meter. In other words, each “head” refers to the *energy density* of the fluid: the amount of energy contained per volume.

At this point, you are probably asking yourself the question, “*What in the world has this to do with electricity?*” You are no doubt familiar with voltage explained in terms of the amount of *pressure* gained or lost by a fluid as it travels through a hydraulic circuit, and in fact it was once common practice for electrical practitioners to refer to potential as “electrical pressure”. As it so happens, this is a very apt analogy, as we have just proven that fluid pressure is equivalent to energy per unit volume, and we also know that electrical potential is defined as the amount of energy carried per unit charge. In other words, electrical potential is the *energy density* of charge carriers (i.e. the amount of energy carried per “volume” of charges), and voltage is the gain or loss of this energy density as current moves from one point to another.

6.2 Metric prefixes

The *metric system* of measurement specifies certain units of measurement for various physical parameters, some of them listed here:

Parameter	Unit	Symbol
Length	Meter	m
Temperature	Celsius or Kelvin	C or K
Mass	Gram	g
Force	Newton	N

These units are useful for measuring any range imaginable, from subatomic to astronomical. In order to make the numerical values easier for human beings to manage, the metric system also includes *prefixes* representing power-of-ten multipliers, some of which are listed here:

Prefix	Symbol	Power-of-ten
Peta	P	$10^{15} = 1,000,000,000,000,000$
Tera	T	$10^{12} = 1,000,000,000,000$
Giga	G	$10^9 = 1,000,000,000$
Mega	M	$10^6 = 1,000,000$
Kilo	k	$10^3 = 1,000$
Milli	m	$10^{-3} = \frac{1}{1,000}$
Micro	μ	$10^{-6} = \frac{1}{1,000,000}$
Nano	n	$10^{-9} = \frac{1}{1,000,000,000}$
Pico	p	$10^{-12} = \frac{1}{1,000,000,000,000}$
Femto	f	$10^{-15} = \frac{1}{1,000,000,000,000,000}$

In order to represent very large or very small quantities all we need to do is combine the right prefix with the unit. For example, a distance of 12,509 meters could be written as 12.509 *kilometers* (12.509 km) because “kilo” simply means *thousand*. Similarly, a mass of 0.000000421 grams could be written as 0.421 *micrograms* (0.421 μg) or 421 *nanograms* (421 ng) because “micro” means *one-millionth* and “nano” means *one-billionth*.

Scientific hand calculators offer display modes and entry functions tailored for the purpose of expressing results and accepting input using standard metric prefix power-of-ten notation. Consider the following photograph of a Texas Instruments model TI-30X IIS calculator computing the current through a 4700 Ohm resistor energized by a 5 Volt source (using Ohm's Law, $I = \frac{V}{R}$):

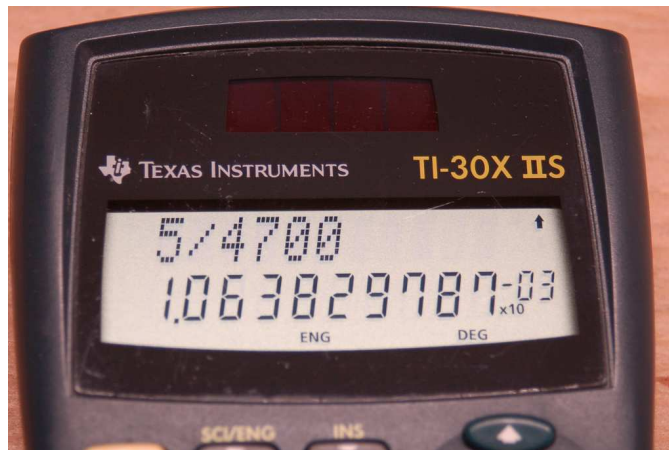

When the calculator has been set to the *Engineering* display mode, all results appear with a $\times 10^x$ label where x is an integer multiple of three to match with the metric prefixes listed previously. Here, the quotient $\frac{5}{4700}$ results in 1.0638×10^{-3} , or 1.0638 milliAmperes (1.0638 mA).

A button marked **EE** (sometimes $\times 10^x$ or simply **E**) allows entry of numerical values in either scientific notation or “engineering” form. Here, the same current calculation is performed entering the 4700 Ohm resistor's value as 4.7 kiloOhms (4.7 k Ω), entered as 4.7E3 in the calculator:

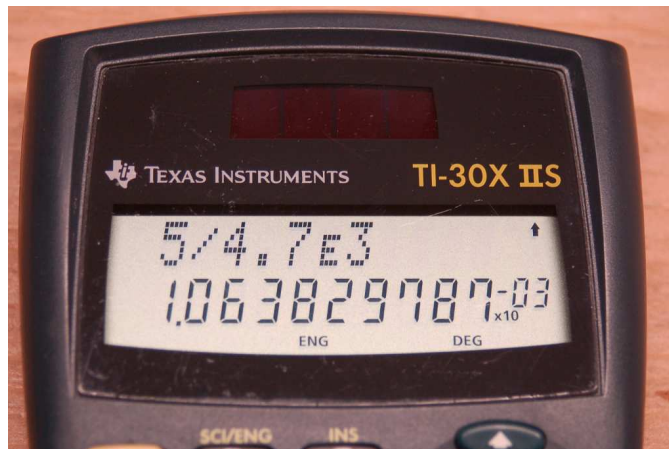

Another example shows the calculation of power dissipated by a $4\ \Omega$ resistor passing a current of 2.8 mA, using Joule's Law ($P = I^2R$) and once again making use of the EE button when entering the current value as 2.8E-3:

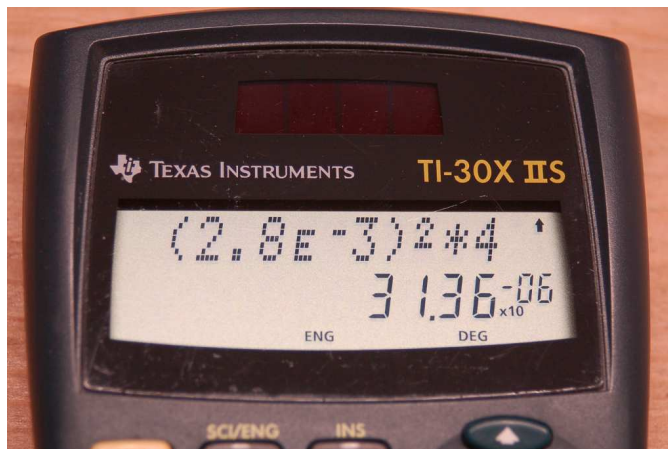

Here, the resulting power dissipation is 31.36 microWatts ($31.36\ \mu\text{W}$).

Some hand calculators provide the Normal/Scientific/Engineering display setting as an option within a general display menu, while others (like the TI-30X IIS) allow faster access by making those settings accessible directly on the front. Note the SCI/ENG function visible above one of the buttons in these photographs.

Engineering mode requires a knowledge of the powers-of-ten associated with common metric prefixes, but once those prefix multipliers are memorized it becomes very valuable in that it saves you from having to track numerical values with many leading or trailing zeroes. For example, without Engineering mode set, our calculated current of 1.0638 mA would be displayed by the calculator as 0.001638. It is surprisingly easy to mis-count the number of repeated characters in a digital display – in this case the number of zeroes displayed in 0.001638 – and so this value might easily be mistaken as 0.01638 (16.38 mA) or 0.0001638 (0.1638 mA or 163.8 μA).

Mathematical formulae in science and engineering generally assume the use of *base units* in their variables. For example, *Ohm's Law* assumes voltage expressed in plain Volts (V), current expressed in plain Amperes (A), and resistance expressed in plain Ohms (Ω). However, for very large and very small quantities, it is more convenient for humans to read and write values using either metric prefixes or scientific notation rather than base units. For example, a voltage of 72 Volts applied across a resistance of 3,500,000 Ohms will result in a current of 0.0002057143 Amperes; but these quantities are much more easily written as 72 Volts, 3.5 megaOhms, and 20.57143 microAmperes, respectively.

Metric prefixes exist for the sole purpose of making very large and very small numbers easier for human beings to write. They are really just short-hand notations for specific powers-of-ten. Thus, 3.5 M Ω is equal to 3.5×10^6 Ohms, or 3.5 *million* Ohms; likewise, 20.57143 μ A is the same as 20.57143×10^{-6} Amperes, or 20.57143 *millionths* of an Ampere.

A very common error made by students new to the use of metric prefixes is to ignore these metric prefixes when inserting values into scientific and engineering formulae. For example, if someone tries to apply Ohm's Law to the example quantities of 72 V and 3.5 M Ω to find current ($I = \frac{V}{R}$) by simply dividing 72 by 3.5, their result will be grossly erroneous, as $72 \div 3.5 = 20.57143$. What this incorrect calculation *actually* finds is that 72 Volts applied across 3.5 Ohms yields a current of 20.57143 Amperes. When you enter "3.5" into a calculator, that calculator has no idea you really mean 3.5 *million* (3.5 *mega*) unless you specifically tell it so. This either requires you manually convert 3.5 M Ω into base units of Ohms (3,500,000 Ohms) by entering 3500000 into the calculator, or by using the calculator's power-of-ten entry key by entering 3.5E6 which means 3.5×10^6 . In all cases, it is your responsibility to convert all metric-prefixed values into base-unit forms suitable for the formula(e) being calculated.

An interesting twist on the theme of base units for mathematical formulae is any formula involving *mass*, in which case the value for m must be in *kilograms* rather than grams. This is in accordance with the meter-kilogram-second (MKS) convention of modern² metric notation where the kilogram rather than the gram is considered to be the "base" unit for mass.

For example, suppose we wished to calculate the kinetic energy of an 80 gram mass traveling at a velocity of 0.79 kilometers per second using the equation $E = \frac{1}{2}mv^2$. To properly calculate energy (E) in Joules, we would need to enter 0.080 for mass (m) in kilograms because 0.080 kg = 80 g, and we would need to enter 790 or 0.79×10^3 or 0.79E3 for velocity (v) in meters per second because 790 m/s = 0.79 km/s. The proper result would be 24,964 Joules, or 24.964 kJ. If we were to ignore these metric prefixes by entering 80 for m and 0.79 for v , we would erroneously obtain a result of 24.964: an answer to a very different scenario where the mass is 80 kilograms rather than 80 grams and has a velocity of 0.79 meters per second rather than 0.79 kilometers per second. So, just like the Ohm's Law example shown previously, we must always properly interpret values having metric prefixes when entering those values into our calculators – because our hand calculators cannot read the metric prefixes written on the page for us – and additionally ensure that any mass values get entered as kilograms rather than grams.

²The older metric convention was centimeter-gram-second (CGS) whereby all formulae using distance or displacement required casting that variable in centimeters rather than meters.

Chapter 7

Questions

This learning module, along with all others in the ModEL collection, is designed to be used in an inverted instructional environment where students independently read¹ the tutorials and attempt to answer questions on their own *prior* to the instructor's interaction with them. In place of lecture², the instructor engages with students in Socratic-style dialogue, probing and challenging their understanding of the subject matter through inquiry.

Answers are not provided for questions within this chapter, and this is by design. Solved problems may be found in the Tutorial and Derivation chapters, instead. The goal here is *independence*, and this requires students to be challenged in ways where others cannot think for them. Remember that you always have the tools of *experimentation* and *computer simulation* (e.g. SPICE) to explore concepts!

The following lists contain ideas for Socratic-style questions and challenges. Upon inspection, one will notice a strong theme of *metacognition* within these statements: they are designed to foster a regular habit of examining one's own thoughts as a means toward clearer thinking. As such these sample questions are useful both for instructor-led discussions as well as for self-study.

¹Technical reading is an essential academic skill for any technical practitioner to possess for the simple reason that the most comprehensive, accurate, and useful information to be found for developing technical competence is in textual form. Technical careers in general are characterized by the need for continuous learning to remain current with standards and technology, and therefore any technical practitioner who cannot read well is handicapped in their professional development. An excellent resource for educators on improving students' reading prowess through intentional effort and strategy is the book *Reading For Understanding – How Reading Apprenticeship Improves Disciplinary Learning in Secondary and College Classrooms* by Ruth Schoenbach, Cynthia Greenleaf, and Lynn Murphy.

²Lecture is popular as a teaching method because it is easy to implement: any reasonably articulate subject matter expert can talk to students, even with little preparation. However, it is also quite problematic. A good lecture always makes complicated concepts seem easier than they are, which is bad for students because it instills a false sense of confidence in their own understanding; reading and re-articulation requires more cognitive effort and serves to verify comprehension. A culture of teaching-by-lecture fosters a debilitating dependence upon direct personal instruction, whereas the challenges of modern life demand independent and critical thought made possible only by gathering information and perspectives from afar. Information presented in a lecture is ephemeral, easily lost to failures of memory and dictation; text is forever, and may be referenced at any time.

GENERAL CHALLENGES FOLLOWING TUTORIAL READING

- Summarize as much of the text as you can in one paragraph of your own words. A helpful strategy is to explain ideas as you would for an intelligent child: as simple as you can without compromising too much accuracy.
- Simplify a particular section of the text, for example a paragraph or even a single sentence, so as to capture the same fundamental idea in fewer words.
- Where did the text make the most sense to you? What was it about the text's presentation that made it clear?
- Identify where it might be easy for someone to misunderstand the text, and explain why you think it could be confusing.
- Identify any new concept(s) presented in the text, and explain in your own words.
- Identify any familiar concept(s) such as physical laws or principles applied or referenced in the text.
- Devise a proof of concept experiment demonstrating an important principle, physical law, or technical innovation represented in the text.
- Devise an experiment to disprove a plausible misconception.
- Did the text reveal any misconceptions you might have harbored? If so, describe the misconception(s) and the reason(s) why you now know them to be incorrect.
- Describe any useful problem-solving strategies applied in the text.
- Devise a question of your own to challenge a reader's comprehension of the text.

GENERAL FOLLOW-UP CHALLENGES FOR ASSIGNED PROBLEMS

- Identify where any fundamental laws or principles apply to the solution of this problem, especially before applying any mathematical techniques.
- Devise a thought experiment to explore the characteristics of the problem scenario, applying known laws and principles to mentally model its behavior.
- Describe in detail your own strategy for solving this problem. How did you identify and organized the given information? Did you sketch any diagrams to help frame the problem?
- Is there more than one way to solve this problem? Which method seems best to you?
- Show the work you did in solving this problem, even if the solution is incomplete or incorrect.
- What would you say was the most challenging part of this problem, and why was it so?
- Was any important information missing from the problem which you had to research or recall?
- Was there any extraneous information presented within this problem? If so, what was it and why did it not matter?
- Examine someone else's solution to identify where they applied fundamental laws or principles.
- Simplify the problem from its given form and show how to solve this simpler version of it. Examples include eliminating certain variables or conditions, altering values to simpler (usually whole) numbers, applying a limiting case (i.e. altering a variable to some extreme or ultimate value).
- For quantitative problems, identify the real-world meaning of all intermediate calculations: their units of measurement, where they fit into the scenario at hand. Annotate any diagrams or illustrations with these calculated values.
- For quantitative problems, try approaching it qualitatively instead, thinking in terms of “increase” and “decrease” rather than definite values.
- For qualitative problems, try approaching it quantitatively instead, proposing simple numerical values for the variables.
- Were there any assumptions you made while solving this problem? Would your solution change if one of those assumptions were altered?
- Identify where it would be easy for someone to go astray in attempting to solve this problem.
- Formulate your own problem based on what you learned solving this one.

GENERAL FOLLOW-UP CHALLENGES FOR EXPERIMENTS OR PROJECTS

- In what way(s) was this experiment or project easy to complete?
- Identify some of the challenges you faced in completing this experiment or project.

- Show how thorough documentation assisted in the completion of this experiment or project.
- Which fundamental laws or principles are key to this system's function?
- Identify any way(s) in which one might obtain false or otherwise misleading measurements from test equipment in this system.
- What will happen if (component X) fails (open/shorted/etc.)?
- What would have to occur to make this system unsafe?

7.1 Conceptual reasoning

These questions are designed to stimulate your analytic and synthetic thinking³. In a Socratic discussion with your instructor, the goal is for these questions to prompt an extended dialogue where assumptions are revealed, conclusions are tested, and understanding is sharpened. Your instructor may also pose additional questions based on those assigned, in order to further probe and refine your conceptual understanding.

Questions that follow are presented to challenge and probe your understanding of various concepts presented in the tutorial. These questions are intended to serve as a guide for the Socratic dialogue between yourself and the instructor. Your instructor’s task is to ensure you have a sound grasp of these concepts, and the questions contained in this document are merely a means to this end. Your instructor may, at his or her discretion, alter or substitute questions for the benefit of tailoring the discussion to each student’s needs. The only absolute requirement is that each student is challenged and assessed at a level equal to or greater than that represented by the documented questions.

It is far more important that you convey your *reasoning* than it is to simply convey a correct answer. For this reason, you should refrain from researching other information sources to answer questions. What matters here is that *you* are doing the thinking. If the answer is incorrect, your instructor will work with you to correct it through proper reasoning. A correct answer without an adequate explanation of how you derived that answer is unacceptable, as it does not aid the learning or assessment process.

You will note a conspicuous lack of answers given for these conceptual questions. Unlike standard textbooks where answers to every other question are given somewhere toward the back of the book, here in these learning modules students must rely on other means to check their work. The best way by far is to debate the answers with fellow students and also with the instructor during the Socratic dialogue sessions intended to be used with these learning modules. Reasoning through challenging questions with other people is an excellent tool for developing strong reasoning skills.

Another means of checking your conceptual answers, where applicable, is to use circuit simulation software to explore the effects of changes made to circuits. For example, if one of these conceptual questions challenges you to predict the effects of altering some component parameter in a circuit, you may check the validity of your work by simulating that same parameter change within software and seeing if the results agree.

³*Analytical* thinking involves the “disassembly” of an idea into its constituent parts, analogous to dissection. *Synthetic* thinking involves the “assembly” of a new idea comprised of multiple concepts, analogous to construction. Both activities are high-level cognitive skills, extremely important for effective problem-solving, necessitating frequent challenge and regular practice to fully develop.

7.1.1 Reading outline and reflections

“Reading maketh a full man; conference a ready man; and writing an exact man” – Francis Bacon

Francis Bacon’s advice is a blueprint for effective education: reading provides the learner with knowledge, writing focuses the learner’s thoughts, and critical dialogue equips the learner to confidently communicate and apply their learning. Independent acquisition and application of knowledge is a powerful skill, well worth the effort to cultivate. To this end, students should read these educational resources closely, journal their own reflections on the reading, and discuss in detail their findings with classmates and instructor(s). You should be able to do all of the following after reading any instructional text:

☑ Briefly **SUMMARIZE THE TEXT** in the form of a journal entry documenting your learning as you progress through the course of study. Share this summary in dialogue with your classmates and instructor. Journaling is an excellent self-test of thorough reading because you cannot clearly express what you have not read or did not comprehend.

☑ Demonstrate **ACTIVE READING STRATEGIES**, including verbalizing your impressions as you read, simplifying long passages to convey the same ideas using fewer words, annotating text and illustrations with your own interpretations, working through mathematical examples shown in the text, cross-referencing passages with relevant illustrations and/or other passages, identifying problem-solving strategies applied by the author, etc. Technical reading is a special case of problem-solving, and so these strategies work precisely because they help solve any problem: paying attention to your own thoughts (metacognition), eliminating unnecessary complexities, identifying what makes sense, paying close attention to details, drawing connections between separated facts, and noting the successful strategies of others.

☑ Identify **IMPORTANT THEMES**, especially **GENERAL LAWS** and **PRINCIPLES**, expounded in the text and express them in the simplest of terms as though you were teaching an intelligent child. This emphasizes connections between related topics and develops your ability to communicate complex ideas to anyone.

☑ Form **YOUR OWN QUESTIONS** based on the reading, and then pose them to your instructor and classmates for their consideration. Anticipate both correct and incorrect answers, the incorrect answer(s) assuming one or more plausible misconceptions. This helps you view the subject from different perspectives to grasp it more fully.

☑ Devise **EXPERIMENTS** to test claims presented in the reading, or to disprove misconceptions. Predict possible outcomes of these experiments, and evaluate their meanings: what result(s) would confirm, and what would constitute disproof? Running mental simulations and evaluating results is essential to scientific and diagnostic reasoning.

☑ Specifically identify any points you found **CONFUSING**. The reason for doing this is to help diagnose misconceptions and overcome barriers to learning.

7.1.2 Foundational concepts

Correct analysis and diagnosis of electric circuits begins with a proper understanding of some basic concepts. The following is a list of some important concepts referenced in this module's full tutorial. Define each of them in your own words, and be prepared to illustrate each of these concepts with a description of a practical example and/or a live demonstration.

Energy

Conservation of Energy

Conservation of Mass

Conservation of Electric Charge

Voltage

Conductors versus Insulators

Resistance

Current

Polarity

Electric circuit

Equipotential points

Electrically common points

Electrically distinct points

Electrically isolated points

Open

Short

Switch

Conventional versus electron flow

7.1.3 Irrigation water

Suppose a gardener desires to store irrigation water in an elevated storage tank, so that at any time a valve may be opened to let water flow from the tank (by gravity) to the garden when needed. That water, when stored in the elevated tank, possesses both mass and height, which means it possesses *energy*.

The water for this storage tank comes from a well, with a submersible pump located at the very bottom providing the means for lifting water out of the well and into the elevated tank.

Consider this scenario carefully, then answer the following questions:

- A very important skill for problem-solving is being able to collect and organize important information. One way to do that is to sketch a simple illustration of the problem scenario, and use that illustration to focus your thoughts and analysis. Specific to this scenario, identify some of the important factors your illustration will show.
- Describe the amount of potential energy possessed by a single molecule of water as it is pumped out of the well, as it is lifted to the height of the tank, as it resides in the tank, and then later as it falls back to ground level at the garden. At which point(s) does the molecule's energy level increase? At which point(s) does the molecule's energy level decrease? At which point(s) does the molecule's energy level remain unchanged over time?
- What factors determine the amount of potential energy possessed by the water in the elevated tank?
- Compare the amount of energy necessary to pump the water out of the well and into the tank, versus the amount of energy released by the water as it flows by gravity from the tank to the garden. Is one of these quantities greater than the other, or are they equal to each other?

Challenges

- Suppose the gardener upgrades the well pump to a model that is more powerful. How would this change in the system affect parameters such as the potential energy of water molecules stored in the tank, the energy released by water as it flows down to the garden, etc.?
- Suppose instead of pumping water out of a well, instead we were pumping some other liquid that was much less dense than water (e.g. gasoline, pumped from a transport truck up to an equivalent elevated storage tank). In other words, each molecule of this new liquid is less massive than a molecule of water. How would this change affect parameters such as potential energy of liquid in the tank, energy released when flowing back to ground level, etc.?

7.1.4 Applying foundational concepts to a two-lamp circuit

Identify which foundational concept(s) apply to each of the declarations shown below regarding the following circuit. If a declaration is true, then identify it as such and note which concept supports that declaration; if a declaration is false, then identify it as such and note which concept is violated by that declaration:

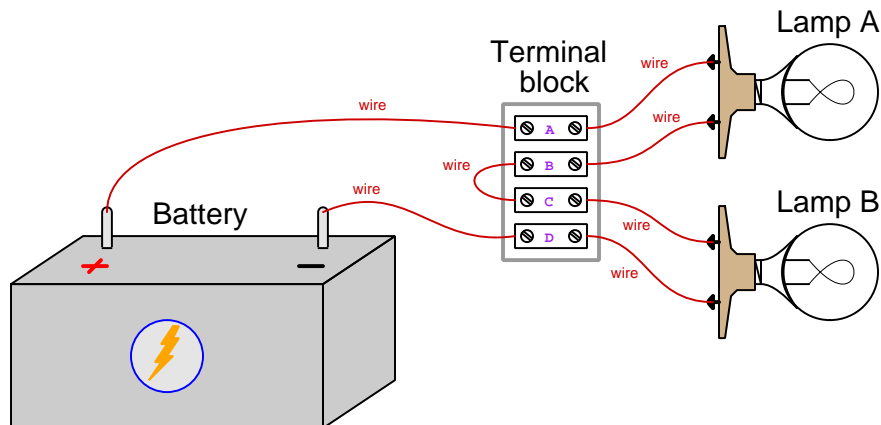

- Voltage exists between terminals A (+) and D (–)
- If Lamp B fails open, the battery will experience zero current
- If Lamp B fails shorted, there will be no voltage across its terminals
- The battery will eventually run out of energy powering the lamps
- If Lamp A fails open, there will be no voltage across its terminals
- If Lamp A fails shorted, Lamp B will experience greater voltage across its terminals
- Voltage exists between terminals B and C
- If the wire connecting terminals B and C together fails open, both lamps will extinguish

Here is a list of foundational concepts for your reference: **Conservation of Energy, Conservation of Mass, behavior of sources vs. loads, effects of open faults, effect of shorted faults, properties of electrically-common points.** More than one of these concepts may apply to a declaration, and some concepts may not apply to any listed declaration at all. Also, feel free to include foundational concepts not listed here.

Challenges

- What will happen in this circuit if we reverse the battery's polarity, connecting + to terminal D and – to terminal A?

7.1.5 A three-lamp circuit

Examine this electric circuit, where a battery powers three identical lamps, and answer the following questions:

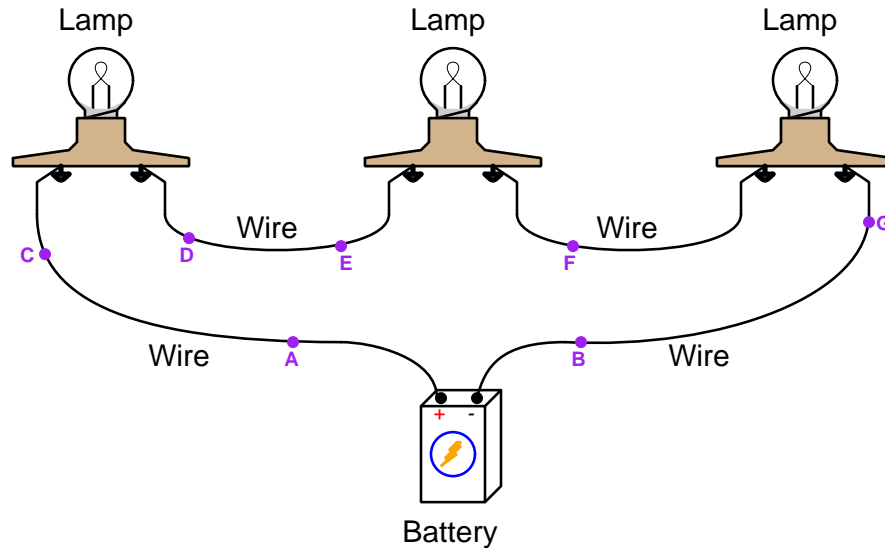

Identify all lettered points in this circuit that are equipotential.

Identify a few pairs of lettered points between which voltage exists. For each of those point pairs, identify which is the “+” and which is the “-”, explaining what those symbols mean in terms of energy.

Identify the two lettered points between which the greatest amount of voltage exists.

Identify what you could do to this circuit to shut off all the lamps.

Select any pair of lettered points between which there exists a voltage, and mark the “polarity” of that voltage using “+” and “-” symbols.

Challenges

- Suppose we were to unscrew one of the lamps from its base, thereby removing the lamp from the circuit. What would happen to the other lamps? How would this alter the distribution of voltage in the circuit? How would this affect current in the circuit? Would these answers depend on *which* light bulb was removed, or not?
- Where does the energy originate, to power the lamps? Can this energy source ever become depleted?
- What would happen if the battery were replaced by one exhibiting a higher amount of voltage?

- What would happen if the battery's terminals were reversed (i.e. negative on the left-hand side and positive on the right-hand side)?

7.1.6 Voltage with no current (and vice-versa)

Is it possible to have a condition of voltage but no current in an electrical circuit? If so, describe an example of this happening. If not, explain the principle of its impossibility.

Is it possible to have a condition of current but no voltage in an electrical circuit? If so, describe an example of this happening. If not, explain the principle of its impossibility.

Voltage is closely related to *energy* and *work*, but it is not exactly the same thing. Describe an example of voltage present in an electrical circuit where no work is being done, contrasted against a different example with voltage present in a circuit while work is being done.

Challenges

- Is a condition of no voltage *and* no current possible? If so, describe an example of it. If not, explain why this is impossible.
- Answer this same question, but in the context of a fluid system rather than an electrical circuit.
- Identify a condition in a circuit of *infinite electrical resistance*. How would this circumstance manifest in terms of voltage and current?
- Identify a condition in a circuit of *zero electrical resistance*. How would this circumstance manifest in terms of voltage and current?
- When a voltage is impressed upon a resistance, that resistance becomes warm. Is any heat dissipated when a voltage is impressed across an *open*? Why or why not?
- When a current travels through a resistance, that resistance becomes warm. Is any heat dissipated when current travels through a *short*? Why or why not?

7.1.7 Lightning

Lightning is a natural, electrical phenomenon. It is caused by the accumulation of vast electrical charges over time resulting from air, dust, and water droplets transporting smaller electrical charges between clouds and the Earth.

Explain how the terms *voltage*, *current*, and *resistance* relate to the process of lightning. In other words, use these three terms to explain the cycle of charge accumulation and lightning discharge.

Challenges

- Where does the energy of a lightning bolt come from, originally?
- Why do some storms generate more frequent lightning strikes than others?
- Is the air during a storm considered an electrical conductor, an electrical insulator, or something else?

7.1.8 A shocking experience

A friend of mine was once installing foam-board insulation in his garage. These foam boards were made of polystyrene with a metal-foil layer on one side, delivered to his home in a bundled stack. As he lifted each board off of the stack, he noticed they tended to adhere to one another by static “cling” which is nothing more than the force created by an electric field between oppositely-charged objects. This charging action began in transport: as the boards were moved to the construction site, they rubbed against each other and caused some charges to transfer from one board to another. None of this, of course, was surprising, as “static cling” is a very common experience in life.

What was surprising to my friend is what happened when he tried to separate two of these foam boards from each other in the stack. As he pried two of the boards apart from each other against the attractive pull of the static charges, a large electric spark jumped from one of the board’s metal-foil layer to his nearest hand! The electric shock was quite powerful and passed through both arms, as the other hand was already in firm contact with the other board’s foil layer.

My friend found it interesting that the spark didn’t happen until he began to pry the boards apart. Surely there was already an electric charge imbalance between the boards, but nothing large enough to create a spark through dry air while the boards were still stacked on top of each other!

Consider this scenario carefully, then answer the following questions:

- Where did the energy originate from to initially charge some of the boards?
- Why do two objects rubbed together always *attract* each other and never *repel*?
- Why did an electric spark develop during the process of separating the two boards from each other, and not previously while the boards were in direct contact?
- Where did the energy for the large electric spark originate?
- Suppose an athlete accidentally drops a weight on their toe while exercising in a gymnasium. Where did the energy causing the injury originate? What condition(s) would make such a weight more or less hazardous to the athlete? Explain how this analogy relates to the scenario of a person getting shocked by two foam insulation boards.

Challenges

- Relate this scenario to the analogy of a hoisted mass or a pumped fluid. What is the equivalent of the electric spark in an analogous hoisted mass or pumped fluid system?
- Will a voltage develop between two foam boards being separated from one another, if they began in a completely uncharged state (i.e. no “static cling” between the two boards)?
- Explain how one could use a metal wire to equalize the electric charge between two foam insulation boards with metal-foil layering, in order to avoid being shocked like this.
- Why is “static” electricity called *static*? By contrast is there such a thing as *dynamic* electricity?

7.1.9 Polarities in a multi-lamp circuit

Consider this circuit comprised of three lamps and one battery, with points labeled A through D and polarity marks shown:

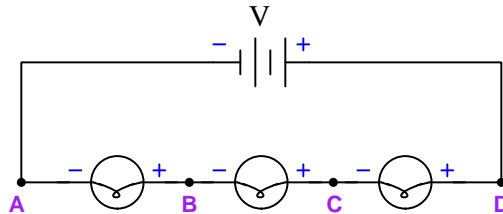

Suppose a student approached you with a question about this circuit. They seem confused on the identification of polarity within this circuit, asking you to explain how it is possible that the points lying between two lamps (e.g. point B and point C) seem to bear both positive and negative polarity labels, while point A is consistently negative and point D is consistently positive. *“How is it possible that point C is both positive and negative, while point D is just positive?”* asks the student.

Answer this student’s question as accurately as you can, identifying and correcting any misconceptions along the way.

An alternative, though seldom used, method of denoting voltage polarity is to use curved arrows instead of + and – symbols. In this symbology, the tip of the arrow represents “+” while the tail of the arrow represents “–” as shown here:

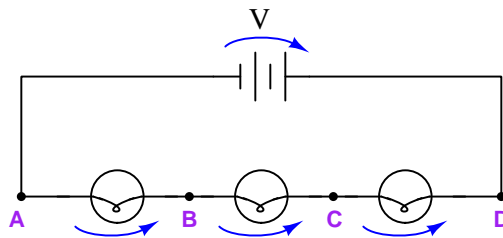

Explain how this alternative method of denoting voltage polarity may help the confused student.

Challenges

- Sketch straight arrows showing the direction of current (using conventional flow) in this circuit, and then explain the relationship between these straight current arrows and the curved voltage arrows. Do you see a pattern?
- Suppose the middle lamp fails shorted. Re-draw curved arrows showing voltage polarity across each of the three lamps in this new condition.
- Suppose the middle lamp fails open. Re-draw curved arrows showing voltage polarity across each of the three lamps in this new condition.

7.1.10 Electrically common versus distinct terminals

Identify whether the terminals of each listed component are *electrically common* to each other, *electrically distinct* from each other, *equipotential* to each other, *not equipotential* to each other, or some combination thereof. Assume each component in question is by itself (i.e. connected to nothing else) unless otherwise specified:

- A switch in its open state =
- A switch in its closed state =
- A fresh battery =
- A completely dead battery with internal resistance =
- A lamp =
- A motor =
- An operating electromechanical generator =
- A stationary electromechanical generator =
- A heater =
- A short length of wire =
- A powered lamp =

Challenges

- Write a general statement defining equipotentiality that may be applied as a test to any specific application.
- Write a general statement defining electrical commonality that may be applied as a test to any specific application.
- Write a general statement defining electrical distinction that may be applied as a test to any specific application.
- For those familiar with formal logic, show how the two concepts of equipotentiality and electrical commonality relate to each other using Venn diagrams.

7.2 Diagnostic reasoning

These questions are designed to stimulate your deductive and inductive thinking, where you must apply general principles to specific scenarios (deductive) and also derive conclusions about the failed circuit from specific details (inductive). In a Socratic discussion with your instructor, the goal is for these questions to reinforce your recall and use of general circuit principles and also challenge your ability to integrate multiple symptoms into a sensible explanation of what's wrong in a circuit. Your instructor may also pose additional questions based on those assigned, in order to further challenge and sharpen your diagnostic abilities.

As always, your goal is to fully *explain* your analysis of each problem. Simply obtaining a correct answer is not good enough – you must also demonstrate sound reasoning in order to successfully complete the assignment. Your instructor's responsibility is to probe and challenge your understanding of the relevant principles and analytical processes in order to ensure you have a strong foundation upon which to build further understanding.

You will note a conspicuous lack of answers given for these diagnostic questions. Unlike standard textbooks where answers to every other question are given somewhere toward the back of the book, here in these learning modules students must rely on other means to check their work. The best way by far is to debate the answers with fellow students and also with the instructor during the Socratic dialogue sessions intended to be used with these learning modules. Reasoning through challenging questions with other people is an excellent tool for developing strong reasoning skills.

Another means of checking your diagnostic answers, where applicable, is to use circuit simulation software to explore the effects of faults placed in circuits. For example, if one of these diagnostic questions requires that you predict the effect of an open or a short in a circuit, you may check the validity of your work by simulating that same fault (substituting a very high resistance in place of that component for an open, and substituting a very low resistance for a short) within software and seeing if the results agree.

7.2.1 Properties of connected points

Identify which of these are true statements:

1. Between two points directly connected to each other by a low-resistance conductor, there is guaranteed to be zero voltage.
2. If zero voltage is measured between two points, those points must be connected to each other by a low-resistance conductor.
3. Between two points that are not connected to each other at all, there is guaranteed to be voltage.
4. If substantial voltage is measured between two points, those points cannot be directly connected to each other by a low-resistance conductor.

Explain how a sound understanding of these principles will help you diagnose circuit faults.

Challenges

- Devise a set of experiments to prove or disprove each of the statements listed above.

7.2.2 Effects of breaks in a motor circuit

In this simple electric circuit, a *motor* is connected to a battery through two wires terminated by *alligator clips* which are spring-loaded clamps designed to make firm contact with metal conductors for the purpose of forming temporary electrical connections:

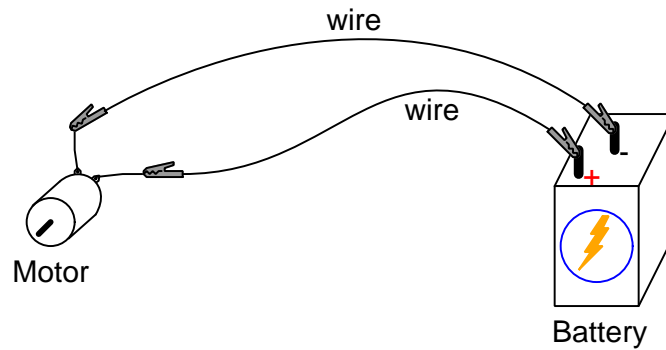

First, identify pairs of points in this circuit between which you would expect a voltage. Label those points with “+” and “-” symbols.

Next, sketch arrows showing the direction of electric current, using “conventional” flow notation.

Suppose that one of the alligator clips becomes disconnected from its motor terminal, so the circuit now looks like this:

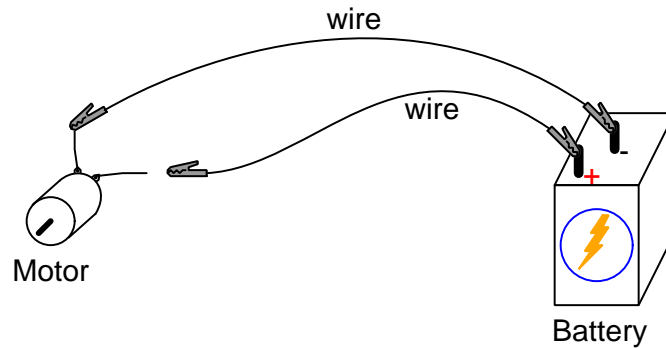

What will the motor do as a result of this wire disconnection happening?

First, identify pairs of points in this circuit between which you would expect a voltage. Label those points with “+” and “-” symbols.

Sketch arrows showing the direction of electric current, using “conventional” flow notation.

Challenges

- Identify points in first circuit that are equipotential to each other.
- Identify points in first circuit that are electrically common to each other.
- Identify a pair of points in either circuit that are equipotential to each other but not electrically common to each other.

7.2.3 Faults in a crude battery/lamp circuit

The following circuit uses a single battery to power two electric lamps. Following this diagram is a set of fault scenarios, where one wire segment or component has failed in a certain way (e.g. failed *open*, failed *shorted*). Your task is to analyze each of the scenarios, one at a time, and identify all potential faults, any one of which could account for the symptoms described.

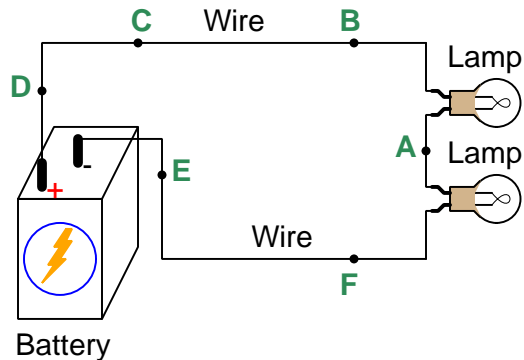

Scenario #1: both lamps are dark, and we measure full battery voltage between points C and E.

Scenario #2: both lamps are dark, and we measure full battery voltage between points A and F.

Scenario #3: both lamps are dark, and we measure zero voltage between points B and F.

Scenario #4: both lamps are dark, and we measure full battery voltage between points C and E, but no voltage between points C and F.

Scenario #5: the upper lamp is dark and the lower lamp is glowing brightly, and we measure full battery voltage between points C and E.

Challenges

- For any of these scenarios, is there a single given symptom conclusive enough to positively identify the location and nature of the fault without any further information? If not, can you postulate one symptom that would be sufficient?
- For any of these scenarios, is there a symptom given to us that does *not* help us diagnose the location or nature of the fault at all?
- For any of these scenarios, what would be a good *next test* to perform with a multimeter to further identify the nature and/or location of the fault?
- Identify points in this circuit that are electrically common with each other (when the circuit is intact and functioning properly).
- Identify points in this circuit that are electrically distinct from each other (when the circuit is intact and functioning properly).

7.2.4 Faults in a terminal block battery/lamp circuit

A common method of circuit construction used in industrial applications is to form connections between electrical wires and components using *terminal blocks*. A “terminal block” is a non-conducting structure with one or more conductive metal strips inside, each strip equipped with either a screw-clamp or a spring clip to secure connections to electrical wires. Each terminal block forms a semi-permanent connection point between multiple wires, and/or between wires and components. The screws or spring clips may be loosened at any time to facilitate changes in the circuit’s configuration, and then re-tightened to form a robust circuit again.

Examine this simple battery and lamp circuit, and then identify any possible faults (opens, shorts) any one of which could account for the symptoms listed in each scenario:

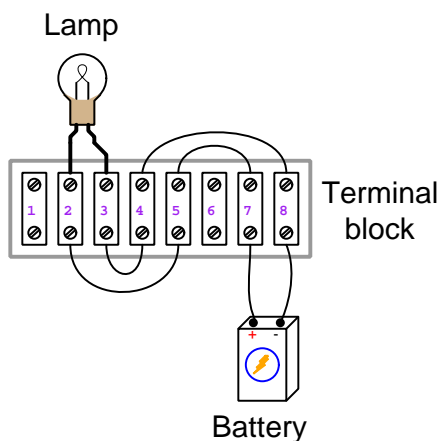

Scenario #1: the lamp is dark, and we measure full battery voltage between terminals 4 and 5.

Scenario #2: the lamp is dark, and we measure full battery voltage between terminals 4 and 8.

Scenario #3: the lamp is dark, and we measure full battery voltage between terminals 2 and 7.

Scenario #4: the lamp is dark, and we measure no battery voltage between terminals 3 and 4.

Challenges

- For any of these scenarios, is there a single given symptom conclusive enough to positively identify the location and nature of the fault without any further information? If not, can you postulate one symptom that would be sufficient?
- For any of these scenarios, is there a symptom given to us that does *not* help us diagnose the location or nature of the fault at all?
- For any of these scenarios, what would be a good *next test* to perform with a multimeter to further identify the nature and/or location of the fault?

- Suppose the wire connecting terminals 4 and 8 broke open. Where would we expect to measure battery voltage in this circuit, and where would we not?
- Identify points in this circuit that are electrically common with each other (when the circuit is intact and functioning properly).
- Identify points in this circuit that are electrically distinct from each other (when the circuit is intact and functioning properly).

Chapter 8

Projects and Experiments

The following project and experiment descriptions outline things you can build to help you understand circuits. With any real-world project or experiment there exists the potential for physical harm. *Electricity can be very dangerous in certain circumstances, and you should follow proper safety precautions at all times!*

8.1 Recommended practices

This section outlines some recommended practices for all circuits you design and construct.

8.1.1 Safety first!

Electricity, when passed through the human body, causes uncomfortable sensations and in large enough measures¹ will cause muscles to involuntarily contract. The overriding of your nervous system by the passage of electrical current through your body is particularly dangerous in regard to your heart, which is a vital muscle. Very large amounts of current can produce serious internal burns in addition to all the other effects.

Cardio-pulmonary resuscitation (CPR) is the standard first-aid for any victim of electrical shock. This is a very good skill to acquire if you intend to work with others on dangerous electrical circuits. You should never perform tests or work on such circuits unless someone else is present who is proficient in CPR.

As a general rule, any voltage in excess of 30 Volts poses a definitive electric shock hazard, because beyond this level human skin does not have enough resistance to safely limit current through the body. “Live” work of any kind with circuits over 30 volts should be avoided, and if unavoidable should only be done using electrically insulated tools and other protective equipment (e.g. insulating shoes and gloves). If you are unsure of the hazards, or feel unsafe at any time, stop all work and distance yourself from the circuit!

A policy I strongly recommend for students learning about electricity is to *never come into electrical contact² with an energized conductor, no matter what the circuit’s voltage³ level!* Enforcing this policy may seem ridiculous when the circuit in question is powered by a single battery smaller than the palm of your hand, but it is precisely this instilled habit which will save a person from bodily harm when working with more dangerous circuits. Experience has taught me that students who learn early on to be careless with safe circuits have a tendency to be careless later with dangerous circuits!

In addition to the electrical hazards of shock and burns, the construction of projects and running of experiments often poses other hazards such as working with hand and power tools, potential

¹Professor Charles Dalziel published a research paper in 1961 called “The Deleterious Effects of Electric Shock” detailing the results of electric shock experiments with both human and animal subjects. The threshold of perception for human subjects holding a conductor in their hand was in the range of 1 milliamperes of current (less than this for alternating current, and generally less for female subjects than for male). Loss of muscular control was exhibited by half of Dalziel’s subjects at less than 10 milliamperes alternating current. Extreme pain, difficulty breathing, and loss of all muscular control occurred for over 99% of his subjects at direct currents less than 100 milliamperes and alternating currents less than 30 milliamperes. In summary, it doesn’t require much electric current to induce painful and even life-threatening effects in the human body! Your first and best protection against electric shock is maintaining an insulating barrier between your body and the circuit in question, such that current from that circuit will be unable to flow through your body.

²By “electrical contact” I mean either directly touching an energized conductor with any part of your body, or indirectly touching it through a conductive tool. The only physical contact you should ever make with an energized conductor is via an electrically insulated tool, for example a screwdriver with an electrically insulated handle, or an insulated test probe for some instrument.

³Another reason for consistently enforcing this policy, even on low-voltage circuits, is due to the dangers that even some low-voltage circuits harbor. A single 12 Volt automobile battery, for example, can cause a surprising amount of damage if short-circuited simply due to the high current levels (i.e. very low internal resistance) it is capable of, even though the voltage level is too low to cause a shock through the skin. Mechanics wearing metal rings, for example, are at risk from severe burns if their rings happen to short-circuit such a battery! Furthermore, even when working on circuits that are simply too low-power (low voltage and low current) to cause any bodily harm, touching them while energized can pose a threat to the circuit components themselves. In summary, it generally wise (and *always* a good habit to build) to “power down” *any* circuit before making contact between it and your body.

contact with high temperatures, potential chemical exposure, etc. You should never proceed with a project or experiment if you are unaware of proper tool use or lack basic protective measures (e.g. personal protective equipment such as safety glasses) against such hazards.

Some other safety-related practices should be followed as well:

- All power conductors extending outward from the project must be *firmly* strain-relieved (e.g. “cord grips” used on line power cords), so that an accidental tug or drop will not compromise circuit integrity.
- All electrical connections must be sound and appropriately made (e.g. soldered wire joints rather than twisted-and-taped; terminal blocks rather than solderless breadboards for high-current or high-voltage circuits). Use “touch-safe” terminal connections with recessed metal parts to minimize risk of accidental contact.
- Always provide overcurrent protection in any circuit you build. *Always*. This may be in the form of a fuse, a circuit breaker, and/or an electronically current-limited power supply.
- Always ensure circuit conductors are rated for more current than the overcurrent protection limit. *Always*. A fuse does no good if the wire or printed circuit board trace will “blow” before it does!
- Always bond metal enclosures to Earth ground for any line-powered circuit. *Always*. Ensuring an equipotential state between the enclosure and Earth by making the enclosure electrically common with Earth ground ensures no electric shock can occur simply by one’s body bridging between the Earth and the enclosure.
- Avoid building a high-energy circuit when a low-energy circuit will suffice. For example, I always recommend beginning students power their first DC resistor circuits using small batteries rather than with line-powered DC power supplies. The intrinsic energy limitations of a dry-cell battery make accidents highly unlikely.
- Use line power receptacles that are GFCI (Ground Fault Current Interrupting) to help avoid electric shock from making accidental contact with a “hot” line conductor.
- Always wear eye protection when working with tools or live systems having the potential to eject material into the air. Examples of such activities include soldering, drilling, grinding, cutting, wire stripping, working on or near energized circuits, etc.
- Always use a step-stool or stepladder to reach high places. Never stand on something not designed to support a human load.
- When in doubt, *ask an expert*. If anything even seems remotely unsafe to you, do not proceed without consulting a trusted person fully knowledgeable in electrical safety.

8.1.2 Other helpful tips

Experience has shown the following practices to be very helpful, especially when students make their own component selections, to ensure the circuits will be well-behaved:

- Avoid resistor values less than 1 k Ω or greater than 100 k Ω , unless such values are definitely necessary⁴. Resistances below 1 k Ω may draw excessive current if directly connected to a voltage source of significant magnitude, and may also complicate the task of accurately measuring current since any ammeter's non-zero resistance inserted in series with a low-value circuit resistor will significantly alter the total resistance and thereby skew the measurement. Resistances above 100 k Ω may complicate the task of measuring voltage since any voltmeter's finite resistance connected in parallel with a high-value circuit resistor will significantly alter the total resistance and thereby skew the measurement. Similarly, AC circuit impedance values should be between 1 k Ω and 100 k Ω , and for all the same reasons.
- Ensure all electrical connections are low-resistance and physically rugged. For this reason, one should avoid *compression splices* (e.g. "butt" connectors), solderless breadboards⁵, and wires that are simply twisted together.
- Build your circuit with **testing** in mind. For example, provide convenient connection points for test equipment (e.g. multimeters, oscilloscopes, signal generators, logic probes).
- Design permanent projects with **maintenance** in mind. The more convenient you make maintenance tasks, the more likely they will get done.
- **Always document and save your work.** Circuits lacking schematic diagrams are more difficult to troubleshoot than documented circuits. Similarly, circuit construction is simpler when a schematic diagram precedes construction. Experimental results are easier to interpret when comprehensively recorded. Consider modern videorecording technology for this purpose where appropriate.
- **Record your steps** when troubleshooting. **Talk to yourself** when solving problems. These simple steps clarify thought and simplify identification of errors.

⁴An example of a necessary resistor value much less than 1 k Ω is a *shunt resistor* used to produce a small voltage drop for the purpose of sensing current in a circuit. Such shunt resistors must be low-value in order not to impose an undue load on the rest of the circuit. An example of a necessary resistor value much greater than 100 k Ω is an electrostatic *drain resistor* used to dissipate stored electric charges from body capacitance for the sake of preventing damage to sensitive semiconductor components, while also preventing a path for current that could be dangerous to the person (i.e. shock).

⁵Admittedly, solderless breadboards are very useful for constructing complex electronic circuits with many components, especially DIP-style integrated circuits (ICs), but they tend to give trouble with connection integrity after frequent use. An alternative for projects using low counts of ICs is to solder IC sockets into prototype printed circuit boards (PCBs) and run wires from the soldered pins of the IC sockets to terminal blocks where reliable temporary connections may be made.

8.1.3 Terminal blocks for circuit construction

Terminal blocks are the standard means for making electric circuit connections in industrial systems. They are also quite useful as a learning tool, and so I highly recommend their use in lieu of solderless breadboards⁶. Terminal blocks provide highly reliable connections capable of withstanding significant voltage and current magnitudes, and they force the builder to think very carefully about component layout which is an important mental practice. Terminal blocks that mount on standard 35 mm DIN rail⁷ are made in a wide range of types and sizes, some with built-in disconnecting switches, some with built-in components such as rectifying diodes and fuseholders, all of which facilitate practical circuit construction.

I recommend every student of electricity build their own terminal block array for use in constructing experimental circuits, consisting of several terminal blocks where each block has at least 4 connection points all electrically common to each other⁸ and at least one terminal block that is a fuse holder for overcurrent protection. A pair of anchoring blocks hold all terminal blocks securely on the DIN rail, preventing them from sliding off the rail. Each of the terminals should bear a number, starting from 0. An example is shown in the following photograph and illustration:

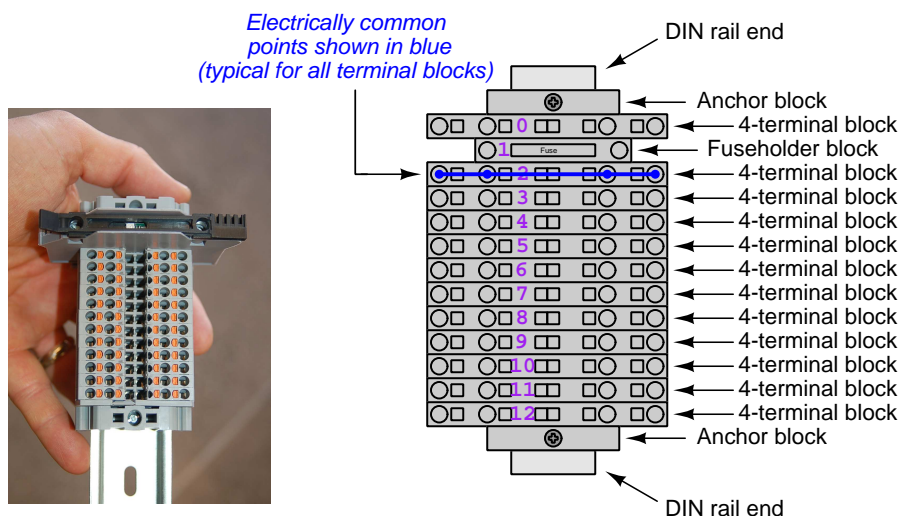

Screwless terminal blocks (using internal spring clips to clamp wire and component lead ends) are preferred over screw-based terminal blocks, as they reduce assembly and disassembly time, and also minimize repetitive wrist stress from twisting screwdrivers. Some screwless terminal blocks require the use of a special tool to release the spring clip, while others provide buttons⁹ for this task which may be pressed using the tip of any suitable tool.

⁶Solderless breadboard are preferable for complicated electronic circuits with multiple integrated “chip” components, but for simpler circuits I find terminal blocks much more practical. An alternative to solderless breadboards for “chip” circuits is to solder chip sockets onto a PCB and then use wires to connect the socket pins to terminal blocks. This also accommodates *surface-mount* components, which solderless breadboards do not.

⁷DIN rail is a metal rail designed to serve as a mounting point for a wide range of electrical and electronic devices such as terminal blocks, fuses, circuit breakers, relay sockets, power supplies, data acquisition hardware, etc.

⁸Sometimes referred to as *equipotential*, *same-potential*, or *potential distribution* terminal blocks.

⁹The small orange-colored squares seen in the above photograph are buttons for this purpose, and may be actuated by pressing with any tool of suitable size.

The following example shows how such a terminal block array might be used to construct a series-parallel resistor circuit consisting of four resistors and a battery:

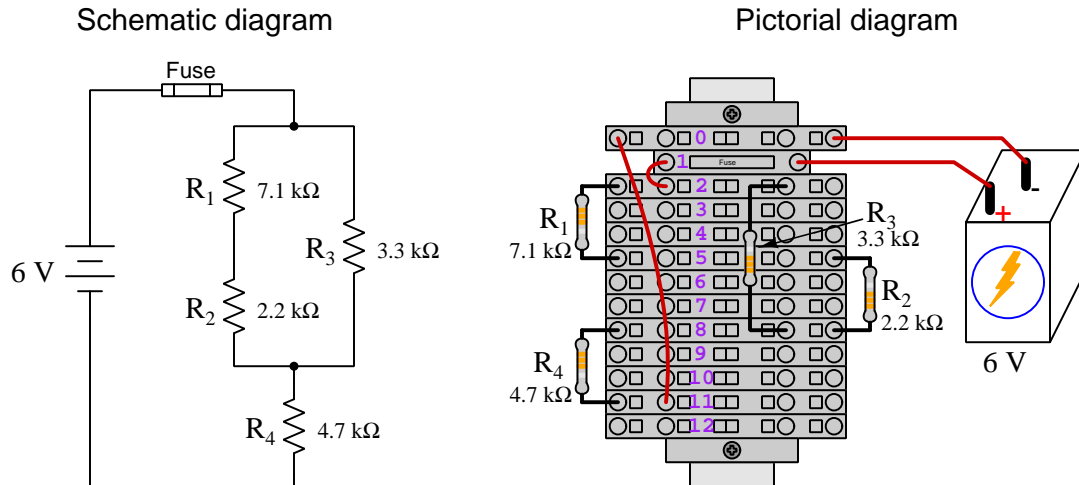

Numbering on the terminal blocks provides a very natural translation to SPICE¹⁰ netlists, where component connections are identified by terminal number:

```
* Series-parallel resistor circuit
v1 1 0 dc 6
r1 2 5 7100
r2 5 8 2200
r3 2 8 3300
r4 8 11 4700
rjmp1 1 2 0.01
rjmp2 0 11 0.01
.op
.end
```

Note the use of “jumper” resistances `rjmp1` and `rjmp2` to describe the wire connections between terminals 1 and 2 and between terminals 0 and 11, respectively. Being resistances, SPICE requires a resistance value for each, and here we see they have both been set to an arbitrarily low value of 0.01 Ohm realistic for short pieces of wire.

Listing all components and wires along with their numbered terminals happens to be a useful documentation method for any circuit built on terminal blocks, independent of SPICE. Such a “wiring sequence” may be thought of as a *non-graphical description* of an electric circuit, and is exceptionally easy to follow.

¹⁰SPICE is computer software designed to analyze electrical and electronic circuits. Circuits are described for the computer in the form of *netlists* which are text files listing each component type, connection node numbers, and component values.

An example of a more elaborate terminal block array is shown in the following photograph, with terminal blocks and “ice-cube” style electromechanical relays mounted to DIN rail, which is turn mounted to a perforated subpanel¹¹. This “terminal block board” hosts an array of thirty five undedicated terminal block sections, four SPDT toggle switches, four DPDT “ice-cube” relays, a step-down control power transformer, bridge rectifier and filtering capacitor, and several fuses for overcurrent protection:

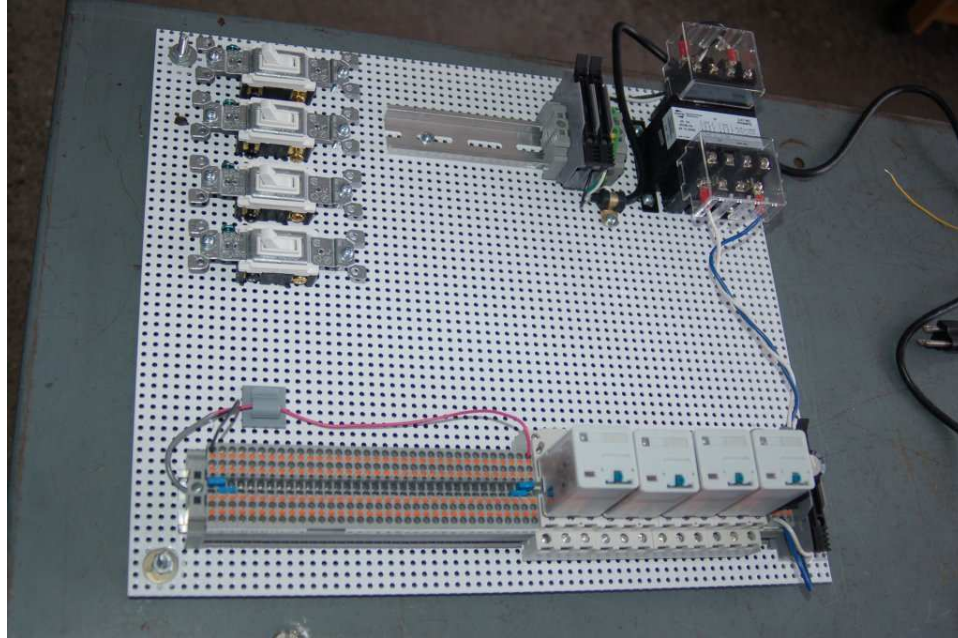

Four plastic-bottomed “feet” support the subpanel above the benchtop surface, and an unused section of DIN rail stands ready to accept other components. Safety features include electrical bonding of the AC line power cord’s ground to the metal subpanel (and all metal DIN rails), mechanical strain relief for the power cord to isolate any cord tension from wire connections, clear plastic finger guards covering the transformer’s screw terminals, as well as fused overcurrent protection for the 120 Volt AC line power and the transformer’s 12 Volt AC output. The perforated holes happen to be on $\frac{1}{4}$ inch centers with a diameter suitable for tapping with 6-32 machine screw threads, their presence making it very easy to attach other sections of DIN rail, printed circuit boards, or specialized electrical components directly to the grounded metal subpanel. Such a “terminal block board” is an inexpensive¹² yet highly flexible means to construct physically robust circuits using industrial wiring practices.

¹¹An electrical *subpanel* is a thin metal plate intended for mounting inside an electrical enclosure. Components are attached to the subpanel, and the subpanel in turn bolts inside the enclosure. Subpanels allow circuit construction outside the confines of the enclosure, which speeds assembly. In this particular usage there is no enclosure, as the subpanel is intended to be used as an open platform for the convenient construction of circuits on a benchtop by students. In essence, this is a modern version of the traditional *breadboard* which was literally a wooden board such as might be used for cutting loaves of bread, but which early electrical and electronic hobbyists used as platforms for the construction of circuits.

¹²At the time of this writing (2019) the cost to build this board is approximately \$250 US dollars.

8.1.4 Conducting experiments

An *experiment* is an exploratory act, a test performed for the purpose of assessing some proposition or principle. Experiments are the foundation of the *scientific method*, a process by which careful observation helps guard against errors of speculation. All good experiments begin with an *hypothesis*, defined by the American Heritage Dictionary of the English Language as:

An assertion subject to verification or proof, as (a) A proposition stated as a basis for argument or reasoning. (b) A premise from which a conclusion is drawn. (c) A conjecture that accounts, within a theory or ideational framework, for a set of facts and that can be used as a basis for further investigation.

Stated plainly, an hypothesis is an *educated guess* about cause and effect. The correctness of this initial guess matters little, because any well-designed experiment will reveal the truth of the matter. In fact, *incorrect* hypotheses are often the most valuable because the experiments they engender lead us to surprising discoveries. One of the beautiful aspects of science is that it is more focused on the process of *learning* than about the status of *being correct*¹³. In order for an hypothesis to be valid, it must be testable¹⁴, which means it must be a claim possible to refute given the right data. Hypotheses impossible to critique are useless.

Once an hypothesis has been formulated, an experiment must be designed to test that hypothesis. A well-designed experiment requires careful regulation of all relevant variables, both for personal safety and for prompting the hypothesized results. If the effects of one particular variable are to be tested, the experiment must be run multiple times with different values of (only) that particular variable. The experiment set up with the “baseline” variable set is called the *control*, while the experiment set up with different value(s) is called the *test* or *experimental*.

For some hypotheses a viable alternative to a physical experiment is a *computer-simulated experiment* or even a *thought experiment*. Simulations performed on a computer test the hypothesis against the physical laws encoded within the computer simulation software, and are particularly useful for students learning new principles for which simulation software is readily available¹⁵.

¹³Science is more about clarifying our view of the universe through a systematic process of error detection than it is about proving oneself to be right. Some *scientists* may happen to have large egos – and this may have more to do with the ways in which large-scale scientific research is *funded* than anything else – but *scientific method* itself is devoid of ego, and if embraced as a practical philosophy is quite an effective stimulant for humility. Within the education system, scientific method is particularly valuable for helping students break free of the crippling fear of *being wrong*. So much emphasis is placed in formal education on assessing correct retention of facts that many students are fearful of saying or doing anything that might be perceived as a mistake, and of course making mistakes (i.e. having one’s hypotheses disproven by experiment) is an indispensable tool for learning. Introducing science in the classroom – *real* science characterized by individuals forming actual hypotheses and testing those hypotheses by experiment – helps students become self-directed learners.

¹⁴This is the principle of *falsifiability*: that a scientific statement has value only insofar as it is liable to disprove given the requisite experimental evidence. Any claim that is unfalsifiable – that is, a claim which can *never* be disproven by any evidence whatsoever – could be completely wrong and we could never know it.

¹⁵A very pertinent example of this is learning how to analyze electric circuits using simulation software such as SPICE. A typical experimental cycle would proceed as follows: (1) Find or invent a circuit to analyze; (2) Apply your analytical knowledge to that circuit, predicting all voltages, currents, powers, etc. relevant to the concepts you are striving to master; (3) Run a simulation on that circuit, collecting “data” from the computer when complete; (4) Evaluate whether or not your hypotheses (i.e. predicted voltages, currents, etc.) agree with the computer-generated results; (5) If so, your analyses are (provisionally) correct – if not, examine your analyses and the computer simulation again to determine the source of error; (6) Repeat this process as many times as necessary until you achieve mastery.

Thought experiments are useful for detecting inconsistencies within your own understanding of some subject, rather than testing your understanding against physical reality.

Here are some general guidelines for conducting experiments:

- The clearer and more specific the hypothesis, the better. Vague or unfalsifiable hypotheses are useless because they will fit *any* experimental results, and therefore the experiment cannot teach you anything about the hypothesis.
- Collect as much data (i.e. information, measurements, sensory experiences) generated by an experiment as is practical. This includes the time and date of the experiment, too!
- *Never* discard or modify data gathered from an experiment. If you have reason to believe the data is unreliable, write notes to that effect, but never throw away data just because you think it is untrustworthy. It is quite possible that even “bad” data holds useful information, and that someone else may be able to uncover its value even if you do not.
- Prioritize *quantitative* data over *qualitative* data wherever practical. Quantitative data is more specific than qualitative, less prone to subjective interpretation on the part of the experimenter, and amenable to an arsenal of analytical methods (e.g. statistics).
- Guard against your own bias(es) by making your experimental results available to others. This allows other people to scrutinize your experimental design and collected data, for the purpose of detecting and correcting errors you may have missed. Document your experiment such that others may independently replicate it.
- Always be looking for sources of error. No physical measurement is perfect, and so it is impossible to achieve *exact* values for any variable. Quantify the amount of uncertainty (i.e. the “tolerance” of errors) whenever possible, and be sure your hypothesis does not depend on precision better than this!
- Always remember that scientific confirmation is provisional – no number of “successful” experiments will prove an hypothesis true for all time, but a single experiment can disprove it. Put into simpler terms, *truth is elusive but error is within reach*.
- Remember that scientific method is about *learning*, first and foremost. An unfortunate consequence of scientific triumph in modern society is that science is often viewed by non-practitioners as an unerring source of truth, when in fact science is an ongoing process of challenging existing ideas to probe for errors and oversights. This is why it is perfectly acceptable to have a failed hypothesis, and why the only truly failed experiment is one where nothing was learned.

The following is an example of a well-planned and executed experiment, in this case a physical experiment demonstrating Ohm's Law.

Planning Time/Date = 09:30 on 12 February 2019

HYPOTHESIS: the current through any resistor should be exactly proportional to the voltage impressed across it.

PROCEDURE: connect a resistor rated 1 k Ohm and 1/4 Watt to a variable-voltage DC power supply. Use an ammeter in series to measure resistor current and a voltmeter in parallel to measure resistor voltage.

RISKS AND MITIGATION: excessive power dissipation may harm the resistor and/or pose a burn hazard, while excessive voltage poses an electric shock hazard. 30 Volts is a safe maximum voltage for laboratory practices, and according to Joule's Law a 1000 Ohm resistor will dissipate 0.25 Watts at 15.81 Volts ($P = V^2 / R$), so I will remain below 15 Volts just to be safe.

Experiment Time/Date = 10:15 on 12 February 2019

DATA COLLECTED:

(Voltage)	(Current)	(Voltage)	(Current)
0.000 V	= 0.000 mA	8.100	= 7.812 mA
2.700 V	= 2.603 mA	10.00 V	= 9.643 mA
5.400 V	= 5.206 mA	14.00 V	= 13.49 mA

Analysis Time/Date = 10:57 on 12 February 2019

ANALYSIS: current definitely increases with voltage, and although I expected exactly one milliAmpere per Volt the actual current was usually less than that. The voltage/current ratios ranged from a low of 1036.87 (at 8.1 Volts) to a high of 1037.81 (at 14 Volts), but this represents a variance of only -0.0365% to +0.0541% from the average, indicating a very consistent proportionality -- results consistent with Ohm's Law.

ERROR SOURCES: one major source of error is the resistor's value itself. I did not measure it, but simply assumed color bands of brown-black-red meant exactly 1000 Ohms. Based on the data I think the true resistance is closer to 1037 Ohms. Another possible explanation is multimeter calibration error. However, neither explains the small positive and negative variances from the average. This might be due to electrical noise, a good test being to repeat the same experiment to see if the variances are the same or different. Noise should generate slightly different results every time.

The following is an example of a well-planned and executed *virtual* experiment, in this case demonstrating Ohm's Law using a computer (SPICE) simulation.

Planning Time/Date = 12:32 on 14 February 2019

HYPOTHESIS: for any given resistor, the current through that resistor should be exactly proportional to the voltage impressed across it.

PROCEDURE: write a SPICE netlist with a single DC voltage source and single 1000 Ohm resistor, then use NGSPICE version 26 to perform a "sweep" analysis from 0 Volts to 25 Volts in 5 Volt increments.

```
* SPICE circuit
v1 1 0 dc
r1 1 0 1000
.dc v1 0 25 5
.print dc v(1) i(v1)
.end
```

RISKS AND MITIGATION: none.

DATA COLLECTED:

DC transfer characteristic Thu Feb 14 13:05:08 2019

Index	v-sweep	v(1)	v1#branch
0	0.000000e+00	0.000000e+00	0.000000e+00
1	5.000000e+00	5.000000e+00	-5.00000e-03
2	1.000000e+01	1.000000e+01	-1.00000e-02
3	1.500000e+01	1.500000e+01	-1.50000e-02
4	2.000000e+01	2.000000e+01	-2.00000e-02
5	2.500000e+01	2.500000e+01	-2.50000e-02

Analysis Time/Date = 13:06 on 14 February 2019

ANALYSIS: perfect agreement between data and hypothesis -- current is precisely 1/1000 of the applied voltage for all values. Anything other than perfect agreement would have probably meant my netlist was incorrect. The negative current values surprised me, but it seems this is just how SPICE interprets normal current through a DC voltage source.

ERROR SOURCES: none.

As gratuitous as it may seem to perform experiments on a physical law as well-established as Ohm's Law, even the examples listed previously demonstrate opportunity for real learning. In the physical experiment example, the student should identify and explain why their data does not perfectly agree with the hypothesis, and this leads them naturally to consider sources of error. In the computer-simulated experiment, the student is struck by SPICE's convention of denoting regular current through a DC voltage source as being *negative* in sign, and this is also useful knowledge for future simulations. Scientific experiments are most interesting when things *do not* go as planned!

Aside from verifying well-established physical laws, simple experiments are extremely useful as educational tools for a wide range of purposes, including:

- Component familiarization (e.g. *Which terminals of this switch connect to the NO versus NC contacts?*)
- System testing (e.g. *How heavy of a load can my AC-DC power supply source before the semiconductor components reach their thermal limits?*)
- Learning programming languages (e.g. *Let's try to set up an "up" counter function in this PLC!*)

Above all, the priority here is to inculcate the habit of hypothesizing, running experiments, and analyzing the results. This experimental cycle not only serves as an excellent method for self-directed learning, but it also works exceptionally well for troubleshooting faults in complex systems, and for these reasons should be a part of every technician's and every engineer's education.

8.1.5 Constructing projects

Designing, constructing, and testing projects is a very effective means of practical education. Within a formal educational setting, projects are generally chosen (or at least vetted) by an instructor to ensure they may be reasonably completed within the allotted time of a course or program of study, and that they sufficiently challenge the student to learn certain important principles. In a self-directed environment, projects are just as useful as a learning tool but there is some risk of unwittingly choosing a project beyond one's abilities, which can lead to frustration.

Here are some general guidelines for managing projects:

- Define your goal(s) before beginning a project: what do you wish to achieve in building it? What, exactly, should the completed project *do*?
- Analyze your project prior to construction. Document it in appropriate forms (e.g. schematic diagrams), predict its functionality, anticipate all associated risks. In other words, *plan ahead*.
- Set a reasonable budget for your project, and stay within it.
- Identify any deadlines, and set reasonable goals to meet those deadlines.
- Beware of *scope creep*: the tendency to modify the project's goals before it is complete.
- Document your progress! An easy way to do this is to use photography or videography: take photos and/or videos of your project as it progresses. Document failures as well as successes, because both are equally valuable from the perspective of learning.

8.2 Experiment: measuring battery voltages

Locate the user's manual provided by the manufacturer for your *multimeter*. Read this manual's instructions for measuring *DC voltage*. "DC" is an acronym standing for "Direct Current" which means electricity flowing in just one direction. This stands in contrast to "AC" (Alternating Current) which is a topic for a later time. Chemical batteries produce DC rather than AC, as do thermoelectric generators, photovoltaic cells (solar cells), and many other common sources of electricity.

Set your multimeter to measure "DC voltage" and then use it to measure the voltage of several batteries, one battery at a time. Pay close attention to the mathematical sign displayed by your meter (i.e. whether the digital display shows the value as being positive or negative) as it relates to the "+" and "-" polarity markings on the battery's metal terminals and the connections of the meter's red and black test leads to those marked terminals.

Experiment with connecting only one of your multimeter's test leads to the battery, connecting the other test lead to some other point (e.g. empty space (air), the metal frame of a table, Earth ground, etc.). Explain the results you obtain from this experiment. What happens when you touch both test leads of your meter to each other (i.e. make them contact the same point)?

Experiment with a pair of batteries connected together by a single wire. A so-called “jumper wire” equipped with “alligator” style spring-clip jaws at each end works well to connect any pair of batteries where the terminals may be gripped by the jaws. 9-volt “transistor” batteries work well for this purpose, as do “lantern” batteries with coil-spring terminals. Try connecting the batteries together in each of the following ways, and take voltage measurements between every pair of points possible in each configuration (e.g. between the terminals of each battery (one battery at a time), between the terminals connected by the wire, between the outer terminals of the battery pair):

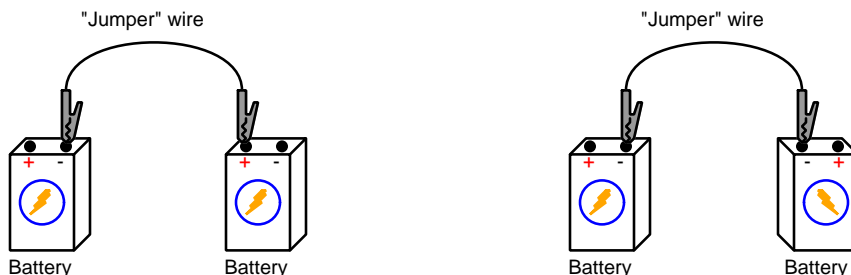

Knowing that voltage is defined as the amount of potential energy either lost or gained by electric charges between two different points, relate the multimeter’s measurements to its test lead connections. What does it mean when the meter registers a larger versus a smaller amount of voltage? What does it mean when the meter registers a positive versus a negative voltage? What does it mean when the meter registers zero voltage?

Challenges

- Show in your multimeter’s user manual the section on measuring DC voltage, and comment on whatever steps you must take to prepare your multimeter to measure this.
- Your multimeter has different *ranges* for voltage measurement. Demonstrate how to set the range of your meter, and why that is an important consideration when using it.
- Demonstrate how to obtain a *positive* DC voltage measurement from a battery, as well as how to obtain a *negative* DC voltage measurement from the same battery. Explain the pattern you see, such that you will be able to correctly predict the sign of your meter’s indication prior to connecting to any DC voltage source.
- Explain how you might combine multiple batteries to achieve a voltage greater than any one of them alone.
- Suppose you took any battery-powered appliance designed to use multiple batteries stacked in-line with each other (e.g. a flashlight) and inserted one of those batteries backwards. How would this affect the operation of the appliance, and why would this be so?
- A *short circuit* is one where a voltage source is connected directly to a very low resistance. Explain why this is a good situation to avoid, and what it might do to one or more of your batteries if attempted.

8.3 Experiment: measuring resistances

Locate the user's manual provided by the manufacturer for your *multimeter*. Read this manual's instructions for measuring *resistance*.

Set your multimeter to measure "resistance" and then experiment by connecting the test leads to different points. *It is imperative that you never connect a resistance meter to an electrical energy source such as a battery!* Not only will the voltage of that source interfere with the meter's function, but it may harm the meter as well. Try holding both of the test leads in mid-air. Now try touching them together. What does your multimeter register in each case? Explain the results based on what you know about resistance.

Use a "jumper wire" to connect both test lead tips together, such that the multimeter is now measuring resistance through its test leads and the wire. How does this measurement compare against the previous measurements?

Test the resistance of several different electronic components from your parts kit. Which components register the most resistance? Which components measure the least resistance? Pay close attention to the metric prefix displayed to the right of your meter's numerical indication: what does "k" mean? What does "M" mean? What does "m" mean?

Use a graphite pencil to draw a thick¹⁶ line on a sheet of paper, and then use your multimeter to measure the amount of resistance from one end of this line to the other. Experiment with different line thicknesses and different line lengths. As a general rule, how do these dimensions affect resistance?

Locate a device in your parts kit called a *potentiometer*. It has three terminals, and either a shaft which may be turned or a slider which may be moved linearly:

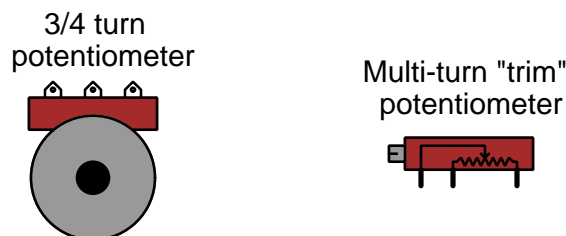

Use alligator-clip "jumper" wires to connect these terminals to your meter's test leads, in order to free your hands to operate the moving portion of the potentiometer. Which two terminals exhibit a constant resistance? Which terminal pairs exhibit an increasing versus a decreasing resistance as the mechanism is moved in one direction?

¹⁶A *very* thick line!

Challenges

- A good self-test of an ohmmeter is to connect its test leads directly together (otherwise known as “shorting” the leads because a direct connection is the shortest, lowest resistance electrical path possible). What should an ohmmeter register when its leads are shorted together? Why?
- Sometimes you will find your multimeter yields a non-zero resistance measurement when you would expect it to measure zero or very nearly zero. Explain why this is.
- Most digital multimeters provide a “relative” function which may be used to cancel out the effects of stray electrical resistance that might otherwise bias your resistance measurements. Locate this feature on your meter and demonstrate its use.
- Try replicating the pencil-line experiment with other writing instruments, such as ink pen or crayon. What results do you obtain? Explain why these results might vary from that of the pencil experiment.

8.4 Experiment: battery and lamp circuit

Construct the following circuit using an incandescent lamp and a battery, using four wires with “alligator-clip” connectors at each end to form a complete circuit. Note that you will need to select a lamp and battery with compatible voltage ratings (e.g. a 6-volt lamp with a 6-volt battery). If you cannot find these components with matching voltage ratings, you may connect a lamp having a greater voltage rating to a battery of lesser voltage. The lamp will glow dimly, but at least it will still work:

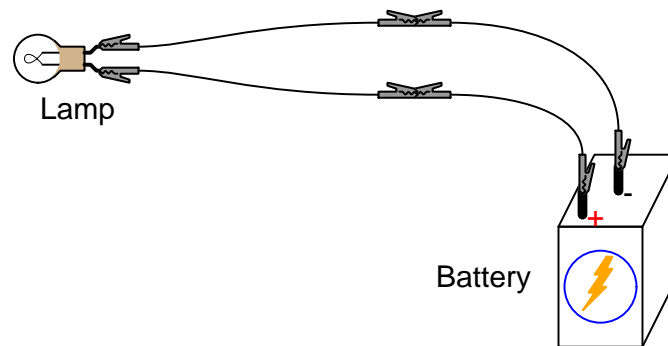

First, predict pairs of points in this circuit between which you would expect to measure voltage. Use your multimeter (set to measure DC voltage) to test your predictions.

Next, predict pairs of points in this circuit you expect would be *equipotential*. Use your multimeter (set to measure DC voltage) to test your predictions.

Disconnect one of the “alligator” clips so that it is no longer making contact with any metal surface. This is called *breaking the circuit*, or *opening* the circuit. What happens to the lamp when you do this? Is there any difference in the lamp’s behavior relative to which portion of the circuit is broken?

Challenges

- A *short circuit* is one where a voltage source is connected directly to a very low resistance. Explain why this is a good situation to avoid, and what it might do to your battery if attempted.
- Based on what you know about voltage, why would it be a bad idea to connect a lamp with a lesser voltage rating to a battery with a greater voltage?
- Explain how any of the *conservation laws* you’ve learned about in the tutorial apply to this circuit.

8.5 Experiment: variable resistance circuit

Connect a rotary potentiometer to a pair of fixed-value resistors and a battery, to form a simple circuit. You will need to decide which two of the three terminals on the potentiometer to connect the alligator-clip wires in order to form a variable resistance. It is recommended that you choose fixed-value resistors with 10 k Ohms (10000 Ohms) of resistance each, and also a potentiometer with the same (maximum) resistance value. The exact amount of resistance doesn't matter much, so long as the three components are approximately equal to each other, and no single resistance is less than 1 k Ohm (1000 Ohms) or greater than 100 k Ohms (100000 Ohms)¹⁷:

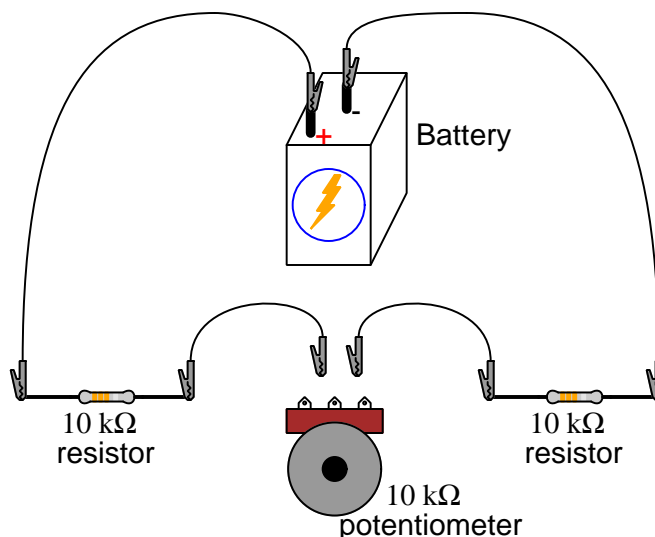

Predict the following voltages, then verify your predictions using your multimeter set to measure DC voltage:

Where would you expect to find the greatest amount of voltage in this circuit? Identify more than one pair of points you could measure between with your meter to obtain this maximum value.

Where would you expect to find the least amount of voltage in this circuit? Identify more than one pair of points you could measure between with your meter to obtain this minimum value.

Where would you expect to find a voltage that increases as the potentiometer shaft rotates clockwise? Identify more than one pair of points you could measure between with your meter to obtain this minimum value.

¹⁷The recommendation to stay within 1 k and 100 k of resistance is primarily based on the loading effects of the multimeter. In circuits with resistances less than 1 k Ohms, a multimeter connected to measure current may impose a significant load on that circuit, thereby decreasing the current below the normal value of the circuit with no meter connected. In circuits with resistances greater than 100 k Ohms, a multimeter connected to measure voltage may impose a significant load on the circuit, causing the voltage to read less than it should. This is why the guidelines of 1 k Ω minimum and 100 k Ω maximum are used throughout this module series, except for special cases.

Where would you expect to find a voltage that increases as the potentiometer shaft rotates counter-clockwise? Identify more than one pair of points you could measure between with your meter to obtain this minimum value.

Identify the “+” and “-” polarities of every voltage in this circuit, and show how you may use your multimeter to verify those polarities.

Challenges

- Choose two random terminals on the potentiometer to connect the wires, then predict what will happen to each resistor’s voltage drop as the potentiometer is turned clockwise, then counter-clockwise.
- Explain why your multimeter will not give sensible results for the measurement of resistance when connected to this live circuit.
- Identify how you could perform accurate measurements of electrical resistance in this circuit with the resistors still connected to each other.
- Will any of these results differ if we reverse the polarity of the battery?

Appendix A

Problem-Solving Strategies

The ability to solve complex problems is arguably one of the most valuable skills one can possess, and this skill is particularly important in any science-based discipline.

- Study principles, not procedures. Don't be satisfied with merely knowing how to compute solutions – learn *why* those solutions work.
- Identify what it is you need to solve, identify all relevant data, identify all units of measurement, identify any general principles or formulae linking the given information to the solution, and then identify any “missing pieces” to a solution. Annotate all diagrams with this data.
- Sketch a diagram to help visualize the problem. When building a real system, always devise a plan for that system and analyze its function *before* constructing it.
- Follow the units of measurement and meaning of every calculation. If you are ever performing mathematical calculations as part of a problem-solving procedure, and you find yourself unable to apply each and every intermediate result to some aspect of the problem, it means you don't understand what you are doing. Properly done, every mathematical result should have practical meaning for the problem, and not just be an abstract number. You should be able to identify the proper units of measurement for each and every calculated result, and show where that result fits into the problem.
- Perform “thought experiments” to explore the effects of different conditions for theoretical problems. When troubleshooting real systems, perform *diagnostic tests* rather than visually inspecting for faults, the best diagnostic test being the one giving you the most information about the nature and/or location of the fault with the fewest steps.
- Simplify the problem until the solution becomes obvious, and then use that obvious case as a model to follow in solving the more complex version of the problem.
- Check for exceptions to see if your solution is incorrect or incomplete. A good solution will work for *all* known conditions and criteria. A good example of this is the process of testing scientific hypotheses: the task of a scientist is not to find support for a new idea, but rather to *challenge* that new idea to see if it holds up under a battery of tests. The philosophical

principle of *reductio ad absurdum* (i.e. disproving a general idea by finding a specific case where it fails) is useful here.

- Work “backward” from a hypothetical solution to a new set of given conditions.
- Add quantities to problems that are qualitative in nature, because sometimes a little math helps illuminate the scenario.
- Sketch graphs illustrating how variables relate to each other. These may be quantitative (i.e. with realistic number values) or qualitative (i.e. simply showing increases and decreases).
- Treat quantitative problems as qualitative in order to discern the relative magnitudes and/or directions of change of the relevant variables. For example, try determining what happens if a certain variable were to increase or decrease before attempting to precisely calculate quantities: how will each of the dependent variables respond, by increasing, decreasing, or remaining the same as before?
- Consider limiting cases. This works especially well for qualitative problems where you need to determine which direction a variable will change. Take the given condition and magnify that condition to an extreme degree as a way of simplifying the direction of the system’s response.
- Check your work. This means regularly testing your conclusions to see if they make sense. This does *not* mean repeating the same steps originally used to obtain the conclusion(s), but rather to use some other means to check validity. Simply repeating procedures often leads to *repeating the same errors* if any were made, which is why alternative paths are better.

Appendix B

Instructional philosophy

“The unexamined circuit is not worth energizing” – Socrates (if he had taught electricity)

These learning modules, although useful for self-study, were designed to be used in a formal learning environment where a subject-matter expert challenges students to digest the content and exercise their critical thinking abilities in the answering of questions and in the construction and testing of working circuits.

The following principles inform the instructional and assessment philosophies embodied in these learning modules:

- The first goal of education is to enhance clear and independent thought, in order that every student reach their fullest potential in a highly complex and inter-dependent world. Robust reasoning is *always* more important than particulars of any subject matter, because its application is universal.
- Literacy is fundamental to independent learning and thought because text continues to be the most efficient way to communicate complex ideas over space and time. Those who cannot read with ease are limited in their ability to acquire knowledge and perspective.
- Articulate communication is fundamental to work that is complex and interdisciplinary.
- Faulty assumptions and poor reasoning are best corrected through challenge, not presentation. The rhetorical technique of *reductio ad absurdum* (disproving an assertion by exposing an absurdity) works well to discipline student’s minds, not only to correct the problem at hand but also to learn how to detect and correct future errors.
- Important principles should be repeatedly explored and widely applied throughout a course of study, not only to reinforce their importance and help ensure their mastery, but also to showcase the interconnectedness and utility of knowledge.

These learning modules were expressly designed to be used in an “inverted” teaching environment¹ where students first read the introductory and tutorial chapters on their own, then individually attempt to answer the questions and construct working circuits according to the experiment and project guidelines. The instructor never lectures, but instead meets regularly with each individual student to review their progress, answer questions, identify misconceptions, and challenge the student to new depths of understanding through further questioning. Regular meetings between instructor and student should resemble a Socratic² dialogue, where questions serve as scalpels to dissect topics and expose assumptions. The student passes each module only after consistently demonstrating their ability to logically analyze and correctly apply all major concepts in each question or project/experiment. The instructor must be vigilant in probing each student’s understanding to ensure they are truly *reasoning* and not just *memorizing*. This is why “Challenge” points appear throughout, as prompts for students to think deeper about topics and as starting points for instructor queries. Sometimes these challenge points require additional knowledge that hasn’t been covered in the series to answer in full. This is okay, as the major purpose of the Challenges is to stimulate analysis and synthesis on the part of each student.

The instructor must possess enough mastery of the subject matter and awareness of students’ reasoning to generate their own follow-up questions to practically any student response. Even completely correct answers given by the student should be challenged by the instructor for the purpose of having students practice articulating their thoughts and defending their reasoning. Conceptual errors committed by the student should be exposed and corrected not by direct instruction, but rather by reducing the errors to an absurdity³ through well-chosen questions and thought experiments posed by the instructor. Becoming proficient at this style of instruction requires time and dedication, but the positive effects on critical thinking for both student and instructor are spectacular.

An inspection of these learning modules reveals certain unique characteristics. One of these is a bias toward thorough explanations in the tutorial chapters. Without a live instructor to explain concepts and applications to students, the text itself must fulfill this role. This philosophy results in lengthier explanations than what you might typically find in a textbook, each step of the reasoning process fully explained, including footnotes addressing common questions and concerns students raise while learning these concepts. Each tutorial seeks to not only explain each major concept in sufficient detail, but also to explain the logic of each concept and how each may be developed

¹In a traditional teaching environment, students first encounter new information via *lecture* from an expert, and then independently apply that information via *homework*. In an “inverted” course of study, students first encounter new information via *homework*, and then independently apply that information under the scrutiny of an expert. The expert’s role in lecture is to simply *explain*, but the expert’s role in an inverted session is to *challenge, critique*, and if necessary *explain* where gaps in understanding still exist.

²Socrates is a figure in ancient Greek philosophy famous for his unflinching style of questioning. Although he authored no texts, he appears as a character in Plato’s many writings. The essence of Socratic philosophy is to leave no question unexamined and no point of view unchallenged. While purists may argue a topic such as electric circuits is too narrow for a true Socratic-style dialogue, I would argue that the essential thought processes involved with scientific reasoning on *any* topic are not far removed from the Socratic ideal, and that students of electricity and electronics would do very well to challenge assumptions, pose thought experiments, identify fallacies, and otherwise employ the arsenal of critical thinking skills modeled by Socrates.

³This rhetorical technique is known by the Latin phrase *reductio ad absurdum*. The concept is to expose errors by counter-example, since only one solid counter-example is necessary to disprove a universal claim. As an example of this, consider the common misconception among beginning students of electricity that voltage cannot exist without current. One way to apply *reductio ad absurdum* to this statement is to ask how much current passes through a fully-charged battery connected to nothing (i.e. a clear example of voltage existing without current).

from “first principles”. Again, this reflects the goal of developing clear and independent thought in students’ minds, by showing how clear and logical thought was used to forge each concept. Students benefit from witnessing a model of clear thinking in action, and these tutorials strive to be just that.

Another characteristic of these learning modules is a lack of step-by-step instructions in the Project and Experiment chapters. Unlike many modern workbooks and laboratory guides where step-by-step instructions are prescribed for each experiment, these modules take the approach that students must learn to closely read the tutorials and apply their own reasoning to identify the appropriate experimental steps. Sometimes these steps are plainly declared in the text, just not as a set of enumerated points. At other times certain steps are implied, an example being assumed competence in test equipment use where the student should not need to be told *again* how to use their multimeter because that was thoroughly explained in previous lessons. In some circumstances no steps are given at all, leaving the entire procedure up to the student.

This lack of prescription is not a flaw, but rather a feature. Close reading and clear thinking are foundational principles of this learning series, and in keeping with this philosophy all activities are designed to *require* those behaviors. Some students may find the lack of prescription frustrating, because it demands more from them than what their previous educational experiences required. This frustration should be interpreted as an unfamiliarity with autonomous thinking, a problem which must be corrected if the student is ever to become a self-directed learner and effective problem-solver. Ultimately, the need for students to read closely and think clearly is more important both in the near-term and far-term than any specific facet of the subject matter at hand. If a student takes longer than expected to complete a module because they are forced to outline, digest, and reason on their own, so be it. The future gains enjoyed by developing this mental discipline will be well worth the additional effort and delay.

Another feature of these learning modules is that they do not treat topics in isolation. Rather, important concepts are introduced early in the series, and appear repeatedly as stepping-stones toward other concepts in subsequent modules. This helps to avoid the “compartmentalization” of knowledge, demonstrating the inter-connectedness of concepts and simultaneously reinforcing them. Each module is fairly complete in itself, reserving the beginning of its tutorial to a review of foundational concepts.

This methodology of assigning text-based modules to students for digestion and then using Socratic dialogue to assess progress and hone students’ thinking was developed over a period of several years by the author with his Electronics and Instrumentation students at the two-year college level. While decidedly unconventional and sometimes even unsettling for students accustomed to a more passive lecture environment, this instructional philosophy has proven its ability to convey conceptual mastery, foster careful analysis, and enhance employability so much better than lecture that the author refuses to ever teach by lecture again.

Problems which often go undiagnosed in a lecture environment are laid bare in this “inverted” format where students must articulate and logically defend their reasoning. This, too, may be unsettling for students accustomed to lecture sessions where the instructor cannot tell for sure who comprehends and who does not, and this vulnerability necessitates sensitivity on the part of the “inverted” session instructor in order that students never feel discouraged by having their errors exposed. *Everyone* makes mistakes from time to time, and learning is a lifelong process! Part of the instructor’s job is to build a culture of learning among the students where errors are not seen as shameful, but rather as opportunities for progress.

To this end, instructors managing courses based on these modules should adhere to the following principles:

- Student questions are always welcome and demand thorough, honest answers. The only type of question an instructor should refuse to answer is one the student should be able to easily answer on their own. Remember, *the fundamental goal of education is for each student to learn to think clearly and independently*. This requires hard work on the part of the student, which no instructor should ever circumvent. Anything done to bypass the student's responsibility to do that hard work ultimately limits that student's potential and thereby does real harm.
- It is not only permissible, but encouraged, to answer a student's question by asking questions in return, these follow-up questions designed to guide the student to reach a correct answer through their own reasoning.
- All student answers demand to be challenged by the instructor and/or by other students. This includes both correct and incorrect answers – the goal is to practice the articulation and defense of one's own reasoning.
- No reading assignment is deemed complete unless and until the student demonstrates their ability to accurately summarize the major points in their own terms. Recitation of the original text is unacceptable. This is why every module contains an "Outline and reflections" question as well as a "Foundational concepts" question in the Conceptual reasoning section, to prompt reflective reading.
- No assigned question is deemed answered unless and until the student demonstrates their ability to consistently and correctly apply the concepts to *variations* of that question. This is why module questions typically contain multiple "Challenges" suggesting different applications of the concept(s) as well as variations on the same theme(s). Instructors are encouraged to devise as many of their own "Challenges" as they are able, in order to have a multitude of ways ready to probe students' understanding.
- No assigned experiment or project is deemed complete unless and until the student demonstrates the task in action. If this cannot be done "live" before the instructor, video-recordings showing the demonstration are acceptable. All relevant safety precautions must be followed, all test equipment must be used correctly, and the student must be able to properly explain all results. The student must also successfully answer all Challenges presented by the instructor for that experiment or project.

Students learning from these modules would do well to abide by the following principles:

- No text should be considered fully and adequately read unless and until you can express every idea *in your own words, using your own examples*.
- You should always articulate your thoughts as you read the text, noting points of agreement, confusion, and epiphanies. Feel free to print the text on paper and then write your notes in the margins. Alternatively, keep a journal for your own reflections as you read. This is truly a helpful tool when digesting complicated concepts.
- Never take the easy path of highlighting or underlining important text. Instead, *summarize* and/or *comment* on the text using your own words. This actively engages your mind, allowing you to more clearly perceive points of confusion or misunderstanding on your own.
- A very helpful strategy when learning new concepts is to place yourself in the role of a teacher, if only as a mental exercise. Either explain what you have recently learned to someone else, or at least *imagine* yourself explaining what you have learned to someone else. The simple act of having to articulate new knowledge and skill forces you to take on a different perspective, and will help reveal weaknesses in your understanding.
- Perform each and every mathematical calculation and thought experiment shown in the text on your own, referring back to the text to see that your results agree. This may seem trivial and unnecessary, but it is critically important to ensuring you actually understand what is presented, especially when the concepts at hand are complicated and easy to misunderstand. Apply this same strategy to become proficient in the use of *circuit simulation software*, checking to see if your simulated results agree with the results shown in the text.
- Above all, recognize that learning is hard work, and that a certain level of frustration is unavoidable. There are times when you will struggle to grasp some of these concepts, and that struggle is a natural thing. Take heart that it will yield with persistent and varied⁴ effort, and never give up!

Students interested in using these modules for self-study will also find them beneficial, although the onus of responsibility for thoroughly reading and answering questions will of course lie with that individual alone. If a qualified instructor is not available to challenge students, a workable alternative is for students to form study groups where they challenge⁵ one another.

To high standards of education,

Tony R. Kuphaldt

⁴As the old saying goes, “Insanity is trying the same thing over and over again, expecting different results.” If you find yourself stumped by something in the text, you should attempt a different approach. Alter the thought experiment, change the mathematical parameters, do whatever you can to see the problem in a slightly different light, and then the solution will often present itself more readily.

⁵Avoid the temptation to simply share answers with study partners, as this is really counter-productive to learning. Always bear in mind that the answer to any question is far less important in the long run than the method(s) used to obtain that answer. The goal of education is to empower one’s life through the improvement of clear and independent thought, literacy, expression, and various practical skills.

Appendix C

Tools used

I am indebted to the developers of many open-source software applications in the creation of these learning modules. The following is a list of these applications with some commentary on each.

You will notice a theme common to many of these applications: a bias toward *code*. Although I am by no means an expert programmer in any computer language, I understand and appreciate the flexibility offered by code-based applications where the user (you) enters commands into a plain ASCII text file, which the software then reads and processes to create the final output. Code-based computer applications are by their very nature *extensible*, while WYSIWYG (What You See Is What You Get) applications are generally limited to whatever user interface the developer makes for you.

The GNU/Linux computer operating system

There is so much to be said about Linus Torvalds' `Linux` and Richard Stallman's `GNU` project. First, to credit just these two individuals is to fail to do justice to the *mob* of passionate volunteers who contributed to make this amazing software a reality. I first learned of `Linux` back in 1996, and have been using this operating system on my personal computers almost exclusively since then. It is *free*, it is completely *configurable*, and it permits the continued use of highly efficient `Unix` applications and scripting languages (e.g. shell scripts, Makefiles, `sed`, `awk`) developed over many decades. `Linux` not only provided me with a powerful computing platform, but its open design served to inspire my life's work of creating open-source educational resources.

Bram Moolenaar's Vim text editor

Writing code for any code-based computer application requires a *text editor*, which may be thought of as a word processor strictly limited to outputting plain-ASCII text files. Many good text editors exist, and one's choice of text editor seems to be a deeply personal matter within the programming world. I prefer `Vim` because it operates very similarly to `vi` which is ubiquitous on `Unix/Linux` operating systems, and because it may be entirely operated via keyboard (i.e. no mouse required) which makes it fast to use.

Donald Knuth's \TeX typesetting system

Developed in the late 1970's and early 1980's by computer scientist extraordinaire Donald Knuth to typeset his multi-volume magnum opus *The Art of Computer Programming*, this software allows the production of formatted text for screen-viewing or paper printing, all by writing plain-text code to describe how the formatted text is supposed to appear. \TeX is not just a markup language for documents, but it is also a Turing-complete programming language in and of itself, allowing useful algorithms to be created to control the production of documents. Simply put, *\TeX is a programmer's approach to word processing*. Since \TeX is controlled by code written in a plain-text file, this means anyone may read that plain-text file to see exactly how the document was created. This openness afforded by the code-based nature of \TeX makes it relatively easy to learn how other people have created their own \TeX documents. By contrast, examining a beautiful document created in a conventional WYSIWYG word processor such as Microsoft **Word** suggests nothing to the reader about *how* that document was created, or what the user might do to create something similar. As Mr. Knuth himself once quipped, conventional word processing applications should be called WYSIAYG (What You See Is *All* You Get).

Leslie Lamport's \LaTeX extensions to \TeX

Like all true programming languages, \TeX is inherently extensible. So, years after the release of \TeX to the public, Leslie Lamport decided to create a massive extension allowing easier compilation of book-length documents. The result was \LaTeX , which is the markup language used to create all ModEL module documents. You could say that \TeX is to \LaTeX as **C** is to **C++**. This means it is permissible to use any and all \TeX commands within \LaTeX source code, and it all still works. Some of the features offered by \LaTeX that would be challenging to implement in \TeX include automatic index and table-of-content creation.

Tim Edwards' **Xcircuit** drafting program

This wonderful program is what I use to create all the schematic diagrams and illustrations (but not photographic images or mathematical plots) throughout the ModEL project. It natively outputs PostScript format which is a true vector graphic format (this is why the images do not pixellate when you zoom in for a closer view), and it is so simple to use that I have never had to read the manual! Object libraries are easy to create for **Xcircuit**, being plain-text files using PostScript programming conventions. Over the years I have collected a large set of object libraries useful for drawing electrical and electronic schematics, pictorial diagrams, and other technical illustrations.

Gimp graphic image manipulation program

Essentially an open-source clone of Adobe's `PhotoShop`, I use `Gimp` to resize, crop, and convert file formats for all of the photographic images appearing in the `MODEL` modules. Although `Gimp` does offer its own scripting language (called `Script-Fu`), I have never had occasion to use it. Thus, my utilization of `Gimp` to merely crop, resize, and convert graphic images is akin to using a sword to slice bread.

SPICE circuit simulation program

`SPICE` is to circuit analysis as `TEX` is to document creation: it is a form of markup language designed to describe a certain object to be processed in plain-ASCII text. When the plain-text “source file” is compiled by the software, it outputs the final result. More modern circuit analysis tools certainly exist, but I prefer `SPICE` for the following reasons: it is *free*, it is *fast*, it is *reliable*, and it is a fantastic tool for *teaching* students of electricity and electronics how to write simple code. I happen to use rather old versions of `SPICE`, version 2g6 being my “go to” application when I only require text-based output. `NGSPICE` (version 26), which is based on Berkeley `SPICE` version 3f5, is used when I require graphical output for such things as time-domain waveforms and Bode plots. In all `SPICE` example netlists I strive to use coding conventions compatible with all `SPICE` versions.

Andrew D. Hwang's ePiX mathematical visualization programming library

This amazing project is a `C++` library you may link to any `C/C++` code for the purpose of generating PostScript graphic images of mathematical functions. As a completely free and open-source project, it does all the plotting I would otherwise use a Computer Algebra System (CAS) such as `Mathematica` or `Maple` to do. It should be said that `ePiX` is *not* a Computer Algebra System like `Mathematica` or `Maple`, but merely a mathematical *visualization* tool. In other words, it won't determine integrals for you (you'll have to implement that in your own `C/C++` code!), but it can graph the results, and it does so beautifully. What I really admire about `ePiX` is that it is a `C++` programming library, which means it builds on the existing power and toolset available with that programming language. Mr. Hwang could have probably developed his own stand-alone application for mathematical plotting, but by creating a `C++` library to do the same thing he accomplished something much greater.

gnuplot mathematical visualization software

Another open-source tool for mathematical visualization is `gnuplot`. Interestingly, this tool is *not* part of Richard Stallman’s GNU project, its name being a coincidence. For this reason the authors prefer “gnu” *not* be capitalized at all to avoid confusion. This is a much “lighter-weight” alternative to a spreadsheet for plotting tabular data, and the fact that it easily outputs directly to an X11 console or a file in a number of different graphical formats (including PostScript) is very helpful. I typically set my `gnuplot` output format to default (X11 on my Linux PC) for quick viewing while I’m developing a visualization, then switch to PostScript file export once the visual is ready to include in the document(s) I’m writing. As with my use of `Gimp` to do rudimentary image editing, my use of `gnuplot` only scratches the surface of its capabilities, but the important points are that it’s *free* and that it *works well*.

Python programming language

Both Python and C++ find extensive use in these modules as instructional aids and exercises, but I’m listing Python here as a *tool* for myself because I use it almost daily as a *calculator*. If you open a Python interpreter console and type `from math import *` you can type mathematical expressions and have it return results just as you would on a hand calculator. Complex-number (i.e. *phasor*) arithmetic is similarly supported if you include the complex-math library (`from cmath import *`). Examples of this are shown in the Programming References chapter (if included) in each module. Of course, being a fully-featured programming language, Python also supports conditionals, loops, and other structures useful for calculation of quantities. Also, running in a console environment where all entries and returned values show as text in a chronologically-ordered list makes it easy to copy-and-paste those calculations to document exactly how they were performed.

Appendix D

Creative Commons License

Creative Commons Attribution 4.0 International Public License

By exercising the Licensed Rights (defined below), You accept and agree to be bound by the terms and conditions of this Creative Commons Attribution 4.0 International Public License (“Public License”). To the extent this Public License may be interpreted as a contract, You are granted the Licensed Rights in consideration of Your acceptance of these terms and conditions, and the Licensor grants You such rights in consideration of benefits the Licensor receives from making the Licensed Material available under these terms and conditions.

Section 1 – Definitions.

a. **Adapted Material** means material subject to Copyright and Similar Rights that is derived from or based upon the Licensed Material and in which the Licensed Material is translated, altered, arranged, transformed, or otherwise modified in a manner requiring permission under the Copyright and Similar Rights held by the Licensor. For purposes of this Public License, where the Licensed Material is a musical work, performance, or sound recording, Adapted Material is always produced where the Licensed Material is synched in timed relation with a moving image.

b. **Adapter’s License** means the license You apply to Your Copyright and Similar Rights in Your contributions to Adapted Material in accordance with the terms and conditions of this Public License.

c. **Copyright and Similar Rights** means copyright and/or similar rights closely related to copyright including, without limitation, performance, broadcast, sound recording, and Sui Generis Database Rights, without regard to how the rights are labeled or categorized. For purposes of this Public License, the rights specified in Section 2(b)(1)-(2) are not Copyright and Similar Rights.

d. **Effective Technological Measures** means those measures that, in the absence of proper authority, may not be circumvented under laws fulfilling obligations under Article 11 of the WIPO Copyright Treaty adopted on December 20, 1996, and/or similar international agreements.

e. **Exceptions and Limitations** means fair use, fair dealing, and/or any other exception or

limitation to Copyright and Similar Rights that applies to Your use of the Licensed Material.

f. **Licensed Material** means the artistic or literary work, database, or other material to which the Licensor applied this Public License.

g. **Licensed Rights** means the rights granted to You subject to the terms and conditions of this Public License, which are limited to all Copyright and Similar Rights that apply to Your use of the Licensed Material and that the Licensor has authority to license.

h. **Licensor** means the individual(s) or entity(ies) granting rights under this Public License.

i. **Share** means to provide material to the public by any means or process that requires permission under the Licensed Rights, such as reproduction, public display, public performance, distribution, dissemination, communication, or importation, and to make material available to the public including in ways that members of the public may access the material from a place and at a time individually chosen by them.

j. **Sui Generis Database Rights** means rights other than copyright resulting from Directive 96/9/EC of the European Parliament and of the Council of 11 March 1996 on the legal protection of databases, as amended and/or succeeded, as well as other essentially equivalent rights anywhere in the world.

k. **You** means the individual or entity exercising the Licensed Rights under this Public License. **Your** has a corresponding meaning.

Section 2 – Scope.

a. License grant.

1. Subject to the terms and conditions of this Public License, the Licensor hereby grants You a worldwide, royalty-free, non-sublicensable, non-exclusive, irrevocable license to exercise the Licensed Rights in the Licensed Material to:

A. reproduce and Share the Licensed Material, in whole or in part; and

B. produce, reproduce, and Share Adapted Material.

2. Exceptions and Limitations. For the avoidance of doubt, where Exceptions and Limitations apply to Your use, this Public License does not apply, and You do not need to comply with its terms and conditions.

3. Term. The term of this Public License is specified in Section 6(a).

4. Media and formats; technical modifications allowed. The Licensor authorizes You to exercise the Licensed Rights in all media and formats whether now known or hereafter created, and to make technical modifications necessary to do so. The Licensor waives and/or agrees not to assert any right or authority to forbid You from making technical modifications necessary to exercise the Licensed Rights, including technical modifications necessary to circumvent Effective Technological Measures.

For purposes of this Public License, simply making modifications authorized by this Section 2(a)(4) never produces Adapted Material.

5. Downstream recipients.

A. Offer from the Licensor – Licensed Material. Every recipient of the Licensed Material automatically receives an offer from the Licensor to exercise the Licensed Rights under the terms and conditions of this Public License.

B. No downstream restrictions. You may not offer or impose any additional or different terms or conditions on, or apply any Effective Technological Measures to, the Licensed Material if doing so restricts exercise of the Licensed Rights by any recipient of the Licensed Material.

6. No endorsement. Nothing in this Public License constitutes or may be construed as permission to assert or imply that You are, or that Your use of the Licensed Material is, connected with, or sponsored, endorsed, or granted official status by, the Licensor or others designated to receive attribution as provided in Section 3(a)(1)(A)(i).

b. Other rights.

1. Moral rights, such as the right of integrity, are not licensed under this Public License, nor are publicity, privacy, and/or other similar personality rights; however, to the extent possible, the Licensor waives and/or agrees not to assert any such rights held by the Licensor to the limited extent necessary to allow You to exercise the Licensed Rights, but not otherwise.

2. Patent and trademark rights are not licensed under this Public License.

3. To the extent possible, the Licensor waives any right to collect royalties from You for the exercise of the Licensed Rights, whether directly or through a collecting society under any voluntary or waivable statutory or compulsory licensing scheme. In all other cases the Licensor expressly reserves any right to collect such royalties.

Section 3 – License Conditions.

Your exercise of the Licensed Rights is expressly made subject to the following conditions.

a. Attribution.

1. If You Share the Licensed Material (including in modified form), You must:

A. retain the following if it is supplied by the Licensor with the Licensed Material:

i. identification of the creator(s) of the Licensed Material and any others designated to receive attribution, in any reasonable manner requested by the Licensor (including by pseudonym if designated);

ii. a copyright notice;

- iii. a notice that refers to this Public License;
- iv. a notice that refers to the disclaimer of warranties;
- v. a URI or hyperlink to the Licensed Material to the extent reasonably practicable;

B. indicate if You modified the Licensed Material and retain an indication of any previous modifications; and

C. indicate the Licensed Material is licensed under this Public License, and include the text of, or the URI or hyperlink to, this Public License.

2. You may satisfy the conditions in Section 3(a)(1) in any reasonable manner based on the medium, means, and context in which You Share the Licensed Material. For example, it may be reasonable to satisfy the conditions by providing a URI or hyperlink to a resource that includes the required information.

3. If requested by the Licensor, You must remove any of the information required by Section 3(a)(1)(A) to the extent reasonably practicable.

4. If You Share Adapted Material You produce, the Adapter's License You apply must not prevent recipients of the Adapted Material from complying with this Public License.

Section 4 – Sui Generis Database Rights.

Where the Licensed Rights include Sui Generis Database Rights that apply to Your use of the Licensed Material:

- a. for the avoidance of doubt, Section 2(a)(1) grants You the right to extract, reuse, reproduce, and Share all or a substantial portion of the contents of the database;
- b. if You include all or a substantial portion of the database contents in a database in which You have Sui Generis Database Rights, then the database in which You have Sui Generis Database Rights (but not its individual contents) is Adapted Material; and
- c. You must comply with the conditions in Section 3(a) if You Share all or a substantial portion of the contents of the database.

For the avoidance of doubt, this Section 4 supplements and does not replace Your obligations under this Public License where the Licensed Rights include other Copyright and Similar Rights.

Section 5 – Disclaimer of Warranties and Limitation of Liability.

a. Unless otherwise separately undertaken by the Licensor, to the extent possible, the Licensor offers the Licensed Material as-is and as-available, and makes no representations or warranties of any kind concerning the Licensed Material, whether express, implied, statutory, or other. This includes, without limitation, warranties of title, merchantability, fitness for a particular purpose, non-infringement, absence of latent or other defects, accuracy, or the presence or absence of errors,

whether or not known or discoverable. Where disclaimers of warranties are not allowed in full or in part, this disclaimer may not apply to You.

b. To the extent possible, in no event will the Licensor be liable to You on any legal theory (including, without limitation, negligence) or otherwise for any direct, special, indirect, incidental, consequential, punitive, exemplary, or other losses, costs, expenses, or damages arising out of this Public License or use of the Licensed Material, even if the Licensor has been advised of the possibility of such losses, costs, expenses, or damages. Where a limitation of liability is not allowed in full or in part, this limitation may not apply to You.

c. The disclaimer of warranties and limitation of liability provided above shall be interpreted in a manner that, to the extent possible, most closely approximates an absolute disclaimer and waiver of all liability.

Section 6 – Term and Termination.

a. This Public License applies for the term of the Copyright and Similar Rights licensed here. However, if You fail to comply with this Public License, then Your rights under this Public License terminate automatically.

b. Where Your right to use the Licensed Material has terminated under Section 6(a), it reinstates:

1. automatically as of the date the violation is cured, provided it is cured within 30 days of Your discovery of the violation; or

2. upon express reinstatement by the Licensor.

For the avoidance of doubt, this Section 6(b) does not affect any right the Licensor may have to seek remedies for Your violations of this Public License.

c. For the avoidance of doubt, the Licensor may also offer the Licensed Material under separate terms or conditions or stop distributing the Licensed Material at any time; however, doing so will not terminate this Public License.

d. Sections 1, 5, 6, 7, and 8 survive termination of this Public License.

Section 7 – Other Terms and Conditions.

a. The Licensor shall not be bound by any additional or different terms or conditions communicated by You unless expressly agreed.

b. Any arrangements, understandings, or agreements regarding the Licensed Material not stated herein are separate from and independent of the terms and conditions of this Public License.

Section 8 – Interpretation.

a. For the avoidance of doubt, this Public License does not, and shall not be interpreted to, reduce, limit, restrict, or impose conditions on any use of the Licensed Material that could lawfully

be made without permission under this Public License.

b. To the extent possible, if any provision of this Public License is deemed unenforceable, it shall be automatically reformed to the minimum extent necessary to make it enforceable. If the provision cannot be reformed, it shall be severed from this Public License without affecting the enforceability of the remaining terms and conditions.

c. No term or condition of this Public License will be waived and no failure to comply consented to unless expressly agreed to by the Licensor.

d. Nothing in this Public License constitutes or may be interpreted as a limitation upon, or waiver of, any privileges and immunities that apply to the Licensor or You, including from the legal processes of any jurisdiction or authority.

Creative Commons is not a party to its public licenses. Notwithstanding, Creative Commons may elect to apply one of its public licenses to material it publishes and in those instances will be considered the “Licensor.” Except for the limited purpose of indicating that material is shared under a Creative Commons public license or as otherwise permitted by the Creative Commons policies published at creativecommons.org/policies, Creative Commons does not authorize the use of the trademark “Creative Commons” or any other trademark or logo of Creative Commons without its prior written consent including, without limitation, in connection with any unauthorized modifications to any of its public licenses or any other arrangements, understandings, or agreements concerning use of licensed material. For the avoidance of doubt, this paragraph does not form part of the public licenses.

Creative Commons may be contacted at creativecommons.org.

Appendix E

References

Fleming, John Ambrose, *Electric Lamps and Electric Lighting* – A course of four lectures on electric illumination delivered at the Royal Institution of Great Britain, “The Electrician” Printing & Publishing Company, Limited, London, England, 1899.

Franklin, Benjamin, *Experiments and Observations on Electricity, made at Philadelphia in America*, London, 1769.

Joule, James Prescott; Scoresby, William; Playfair, Lyon; Thompson, William, *The Scientific Papers of James Prescott Joule*, The Physical Society of London, London, 1884.

Giancoli, Douglas C., *Physics for Scientists & Engineers*, Third Edition, Prentice Hall, Upper Saddle River, NJ, 2000.

Maxwell, James Clerk, *A Treatise on Electricity and Magnetism*, Volume I, Third Edition, Clarendon Press, Oxford, 1904.

Appendix F

Version history

This is a list showing all significant additions, corrections, and other edits made to this learning module. Each entry is referenced by calendar date in reverse chronological order (newest version first), which appears on the front cover of every learning module for easy reference. Any contributors to this open-source document are listed here as well.

2 May 2025 – corrected a typographical error in the “Benjamin Franklin on the nature of electricity” Historical Reference section where I wrote “missing” instead of “hissing”. This was a transcription error on my part.

16 September 2024 – minor edit to the Introduction chapter.

25 August 2024 – added another challenging concept reference to the Introduction chapter.

18-21 August 2024 – added another section to the Introduction chapter specifically for challenges related to this module’s topic.

21 July 2024 – added more learning outcomes and assessment methods to the Introduction chapter.

10-17 June 2024 – divided the Introduction chapter into sections, one for students and one for instructors, and added content to the instructor section recommending learning outcomes and measures.

20 May 2024 – very minor edits to the wording and formatting within the Simplified Tutorial.

14 May 2024 – added an analogy of distance to help explain the relative nature of voltage, to the “Concept review” section of the Full Tutorial.

5 February 2024 – added a new “Derivations and Technical References” section on Occam’s Razor as a general troubleshooting principle.

23 August 2023 – corrected a typographical error in the Full Tutorial chapter courtesy of Nick Brown.

8 June 2023 – minor edit to image_6738.

15-18 May 2023 – edited the Full Tutorial chapter for better readability. Also added a Case Tutorial section showing circuit potentials color-coded in open and shorted circuits, both electrical and hydraulic.

27 November 2022 – placed questions at the top of the itemized list in the Introduction chapter prompting students to devise experiments related to the tutorial content.

14-24 August 2022 – minor edits to the Full Tutorial, with the intention of streamlining it for maximum readability. Also, corrected an error in the “Applying foundational concepts to a two-lamp circuit” Conceptual Reasoning question.

7 June 2022 – typographical error correction in the Simplified Tutorial chapter, where the word “of” should have been “or”.

2 June 2022 – minor edits to the Simplified Tutorial chapter.

10 February 2022 – divided the Full Tutorial chapter into sections.

25 August 2021 – added bullet-point question to the “Applying foundational concepts to a two-lamp circuit” Conceptual Reasoning question.

22 July 2021 – added comments in the Case Tutorial and Tutorial chapters clarifying how conservation laws apply to voltage and current differently. Both energy and electric charge are conserved quantities, but their conservation in an electric circuit take different forms: energy is conserved in that total energy out equals total energy in; charge is conserved in that electric charges are recycled in the circuit and never increase or decrease in total number. Also streamlined text in the Simplified Tutorial chapter.

18 July 2021 – added an “Applying foundational concepts...” question to the Conceptual Reasoning section of the Questions chapter.

9 July 2021 – replaced some TeX-style italicizing markup with LaTeX-style.

7 June 2021 – added Case Tutorial showing simple circuit as a continuity tester.

21 May 2021 – re-wrote the Simplified Tutorial chapter, and fixed some spelling errors elsewhere.

25 January 2021 – added Case Tutorial showing the money/voltage analogy.

21 January 2021 – minor additions to the Introduction chapter and to the Full Tutorial chapter.

24 September 2020 – added more content to the Introduction chapter, including references to the “Reading outline and reflections” and “Foundational concepts” subsections. This is intended for helping students new to inverted instruction adapt to the expectations of courses based on these modules, where daily reading of these texts is fundamental to learning. Many students enter college unfamiliar with how to outline texts, and so they need guidance on how to do so.

3 September 2020 – added Technical Reference section on metric prefixes.

23 August 2020 – significantly edited the Introduction chapter to make it more suitable as a pre-study guide and to provide cues useful to instructors leading “inverted” teaching sessions.

20 July 2020 – added “Conventional versus electron flow” to the Foundational concepts list.

13 July 2020 – added “Electrically isolated points” to the Foundational concepts list.

21 January 2020 – corrected a typographical error in one of the instructor notes.

21 September 2019 – added an Historical Reference: James Prescott Joule’s 1847 lecture on the conservation of energy.

14 September 2019 – removed an empty Example section from the Case Tutorial chapter.

2 September 2019 – simplified some of the text in the Simplified Tutorial, and also added a Case Tutorial chapter.

26 August 2019 – added mention of difficult concepts to the Introduction.

20 May 2019 – added some Challenge questions.

14 May 2019 – minor edit to wording in Full Tutorial. Also, separated John Ambrose Fleming’s discussion of electric potential from James Clerk Maxwell’s.

5 November 2018 – retitled Historical References section(s) so as to not be redundant to the “Historical References” chapter.

September 2018 – edited the Introduction to make it more of a condensed tutorial, so that it functions as the “first-step” in a series of “vertical texts” on this topic. Also renamed “Derivations and Technical References” chapter to “Historical References”. Added a new “Derivations and Technical References” chapter and populated it with a tutorial on Bernoulli’s equation and how that relates to electrical potential by analogy.

August 2018 – added a “Derivations and Technical References” chapter with historical notes from Benjamin Franklin’s writings as well as James Clerk Maxwell’s writings. Included my own comments about the folly of attempting to define electrical potential at any single point. Also, made minor edits to Introduction and tutorial chapters.

July 2018 – added a References chapter.

May 2018 – minor changes to one of the illustrations in the Simplified Tutorial, and some of the paragraphs. Minor edit to open vs. shorted switch illustration, relating open with electrical isolation (no current) and relating shorted with electrical commonality (no voltage).

April 2018 – added a Simplified Tutorial chapter, and also clarified some of the explanations and graphic images in the Full Tutorial chapter.

August 2017 – added a conceptual question applying curved-arrow notation for representing voltage polarity. Added the word “deposit” to the bank courier analogy as the counterpart to the word “withdrawal”. Deleted an extra word in one of the diagnostic question sentences.

July 2017 – Minor edits to the Full Tutorial. Edited image_0001.eps for better readability of text. Added a new diagnostic question. Introduced the concept of *electrically distinct* points.

June 2017 – Edited image_0010.eps to include “A” and “B” labels which were mentioned in the caption but missing from the actual diagram.

February 2017 – Added a conceptual question challenging students to identify equipotentiality and electrical commonality for a list of electrical components.

December 2016 – More careful distinctions made between *electrically common* points versus *equipotential points* (electrically common points are always equipotential, but equipotential points are not necessarily electrically common).

October 2016 – created changelog for future use.

September 2016 – document first published.

Index

- AC, 121
- Adding quantities to a qualitative problem, 130
- Alligator clip, 122
- Alternating Current, 121
- Ammeter, 13
- Ampere, 36
- Anion, 45
- Annotating diagrams, 129

- Bernoulli's equation, 46
- Bernoulli, Daniel, 77
- Blind, pipe, 54
- Breadboard, solderless, 112, 113
- Breadboard, traditional, 115

- Cardio-Pulmonary Resuscitation, 110
- Cation, 45
- Cause, root, 29
- CGS system of units, 83
- Charge, 42
- Charge carrier, 34, 45
- Checking for exceptions, 130
- Checking your work, 130
- Chemical reaction, 43
- Circuit, 45, 47
- Circuit, open, 15
- Circuit, short, 17
- Closed, 53
- Code, computer, 137
- Conduction in gases, 45
- Conduction in liquids, 45
- Conduction in metals, 45
- Conductor, 34, 45, 59
- Conservation of Electric Charge, 37, 42, 46, 54
- Conservation of Energy, 34, 37, 41, 46, 78
- Conservation of Mass, 37, 41, 46
- Conservation of Momentum, 41
- Conservation of Spin, 41
- Continuity, 54
- Conventional flow notation, 50, 60, 61
- Coulomb, 46
- CPR, 110
- Current, 13, 36, 47, 50
- Current, electric, 45

- Dalziel, Charles, 110
- DC, 121
- Dimensional analysis, 129
- DIN rail, 113
- DIP, 112
- Direct Current, 121

- Edwards, Tim, 138
- Electric charge, 13, 42
- Electric charge carrier, 34
- Electric current, 45
- Electric field, 42
- Electric potential, 63, 76
- Electric shock, 110
- Electrical resistance, 45
- Electrically common points, 11, 50, 53, 55, 100, 111
- Electrically distinct points, 11, 50, 100
- Electrically isolated points, 53
- Electricity, 34
- Electrochemical cell, 52
- Electrolysis cell, 52
- Electromagnetic induction, 52
- Electromotive force, 6
- Electron, 60
- Electron flow notation, 50, 60, 61
- Electrostatic attraction, 42
- Electrostatic repulsion, 42
- Elevation head, 46

- EMF, 6
- Enclosure, electrical, 115
- Energy, 40, 47
- Energy density, 79
- Energy, kinetic, 40, 76
- Energy, potential, 40, 47, 76
- Equipotential points, 11, 50, 55, 100, 111, 113, 125
- Escape velocity, 63
- Euler, Leonhard, 77
- Experiment, 116
- Experimental guidelines, 117

- Field, 42
- First Law of Thermodynamics, 34
- Franklin, Benjamin, 58

- Gas discharge lamp, 43
- Graph values to solve a problem, 130
- Gravitational field, 42
- Greenleaf, Cynthia, 85

- Head, 46
- Head (fluid), 77
- Head, fluid, 46
- How to teach with these modules, 132
- Hwang, Andrew D., 139

- IC, 112
- Identify given data, 129
- Identify relevant principles, 129
- Instructions for projects and experiments, 133
- Insulator, 34, 45, 59
- Intermediate results, 129
- Inverted instruction, 132

- Jumper wire, 13, 14, 53, 122, 123

- Kinetic energy, 40, 76
- Knuth, Donald, 138

- Lamp, gas-discharge, 43
- Lampert, Leslie, 138
- Limiting cases, 53, 130
- Load, 18, 46, 47, 49

- Magnetic field, 42

- Mass, 41
- Maxwell, James Clerk, 57, 62, 63
- Metacognition, 90
- MKS system of units, 83
- Momentum, 41
- Moolenaar, Bram, 137
- Multimeter, 121, 123
- Murphy, Lynn, 85

- Negative charge, 42

- Occam's Razor, 26
- Ockham, Sir William of, 26
- Ohm, 37
- Ohm's Law, 52
- Open, 15, 20–22, 53, 54
- Open-source, 137

- Photoelectric effect, 52
- Piezoelectricity, 52
- Pipe blind, 54
- Plasma, 45
- Polarity, 47
- Polarity, voltage, 51
- Positive charge, 42
- Potential, 18, 36
- Potential difference, 36, 44
- Potential distribution, 113
- Potential energy, 40, 47, 76
- Potential, electric, 63, 76
- Pressure, 18, 36
- Pressure differential, 18
- Pressure head, 46
- Problem-solving: annotate diagrams, 129
- Problem-solving: check for exceptions, 130
- Problem-solving: checking work, 130
- Problem-solving: dimensional analysis, 129
- Problem-solving: graph values, 130
- Problem-solving: identify given data, 129
- Problem-solving: identify relevant principles, 129
- Problem-solving: interpret intermediate results, 129
- Problem-solving: limiting cases, 130
- Problem-solving: qualitative to quantitative, 130
- Problem-solving: quantitative to qualitative, 130
- Problem-solving: reductio ad absurdum, 130

- Problem-solving: simplify the system, 129
- Problem-solving: thought experiment, 117, 129
- Problem-solving: track units of measurement, 129
- Problem-solving: visually represent the system, 129
- Problem-solving: work in reverse, 130
- Project management guidelines, 120

- Qualitatively approaching a quantitative problem, 130

- Razor, Occam's, 26
- Reaction, chemical, 43
- Reading Apprenticeship, 85
- Reductio ad absurdum, 130–132
- Resistance, 37, 45–47, 50, 52
- Root cause, 29

- Safety, electrical, 110
- Schoenbach, Ruth, 85
- Scientific method, 90, 116
- Scope creep, 120
- Second Law of Thermodynamics, 34
- Seebeck effect, 52
- Short, 17, 23, 53, 55
- Shunt resistor, 112
- Simplifying a system, 129
- Socrates, 131
- Socratic dialogue, 132
- Solderless breadboard, 112, 113
- Source, 18, 46, 47, 49
- SPICE, 85, 117
- SPICE netlist, 114
- Spin, particle, 41
- Stallman, Richard, 137
- Static cling, 98
- Steady state condition, 50
- Subpanel, 115
- Surface mount, 113
- Switch, 53

- Terminal block, 106, 111–115
- Thermodynamics, Laws of, 34
- Thermoelectric generator, 52
- Thought experiment, 117, 129

- Torvalds, Linus, 137
- Units of measurement, 129
- Velocity head, 46
- Visualizing a system, 129
- Volt, 36
- Voltage, 13, 18, 44, 46, 47, 76
- Voltmeter, 13

- Weisbach, Julius, 77
- Wiring sequence, 114
- Work, 42
- Work in reverse to solve a problem, 130
- WYSIWYG, 137, 138