

**Recommended schedule**

---

Day 1

Topics: *Magnetism, electromagnetism, and electromagnetic induction*

Questions: *1 through 20*

Lab Exercises: *Electromagnetism (question 71)*

**MIT 8.02 video clip: Disk 2, Lecture 14; Single-wire field demo 17:32 to 18:35**

**MIT 8.02 video clip: Disk 2, Lecture 14; Twin-wire field demo 19:08 to 20:14**

**MIT 8.02 video clip: Disk 2, Lecture 11; Electromagnetism demos 6:50 to 12:45**

**MIT 8.02 video clip: Disk 2, Lecture 11; Forces between two wires 12:56 to 17:20**

**MIT 8.02 video clip: Disk 3, Lecture 15; Solenoid coil demos 23:00 to 27:15**

**MIT 8.02 video clip: Disk 3, Lecture 16; Electromagnetic induction 10:30 to 12:30**

---

Day 2

Topics: *Applications of electromagnetism and induction, Lenz's Law*

Questions: *21 through 40*

Lab Exercise: *Electromagnetic induction (question 72)*

**MIT 8.02 video clip: Disk 3, Lecture 21; Solenoid and armature demo 20:30 to 22:55**

**MIT 8.02 video clip: Disk 2, Lecture 11; Torque on wire loop demo 46:34 to end**

**MIT 8.02 video clip: Disk 3, Lecture 21; Homemade motor demo 4:20 to 5:55**

**Demo: Use powerful magnet(s) and aluminum coin to show Lenz's Law**

**MIT 8.02 video clip: Disk 3, Lecture 17; Damped pendulum demo 38:00 to 41:50**

**MIT 8.02 video clip: Disk 3, Lecture 17; Ring drop demo 45:10 to 48:51**

**Demo: Ammeter showing current drawn by electric motor under varying load**

---

Day 3

Topics: *Introduction to Thévenin's and Norton's theorems*

Questions: *41 through 55*

Lab Exercise: *Thévenin's theorem (question 73)*

**Socratic Electronics animation: Thévenin's theorem demonstrated**

**Demo: Build a Thévenin equivalent circuit for a more complex circuit**

---

Day 4

Topics: *Thévenin's, Norton's, and Maximum Power Transfer theorems*

Questions: *56 through 70*

Lab Exercise: *Thévenin's theorem (question 73, continued)*

---

Day 5

Exam 2: *includes Thévenin equivalent circuit performance assessment*

Lab Exercise: *Troubleshooting practice (loaded voltage divider circuit – question 74)*

---

Practice and challenge problems

Questions: *77 through the end of the worksheet*

---

Impending deadlines

**Troubleshooting assessment (voltage divider) due at end of ELTR105, Section 3**

Question 75: Troubleshooting log

Question 76: Sample troubleshooting assessment grading criteria

Skill standards addressed by this course section

---

*EIA Raising the Standard; Electronics Technician Skills for Today and Tomorrow, June 1994*

**B Technical Skills – DC circuits**

- B.01** Demonstrate an understanding of sources of electricity in DC circuits.
- B.03** Demonstrate an understanding of the meaning of and relationships among and between voltage, current, resistance and power in DC circuits.
- B.06** Demonstrate an understanding of magnetic properties of circuits and devices.

**B Basic and Practical Skills – Communicating on the Job**

- B.01** Use effective written and other communication skills. *Met by group discussion and completion of labwork.*
- B.03** Employ appropriate skills for gathering and retaining information. *Met by research and preparation prior to group discussion.*
- B.04** Interpret written, graphic, and oral instructions. *Met by completion of labwork.*
- B.06** Use language appropriate to the situation. *Met by group discussion and in explaining completed labwork.*
- B.07** Participate in meetings in a positive and constructive manner. *Met by group discussion.*
- B.08** Use job-related terminology. *Met by group discussion and in explaining completed labwork.*
- B.10** Document work projects, procedures, tests, and equipment failures. *Met by project construction and/or troubleshooting assessments.*

**C Basic and Practical Skills – Solving Problems and Critical Thinking**

- C.01** Identify the problem. *Met by research and preparation prior to group discussion.*
- C.03** Identify available solutions and their impact including evaluating credibility of information, and locating information. *Met by research and preparation prior to group discussion.*
- C.07** Organize personal workloads. *Met by daily labwork, preparatory research, and project management.*
- C.08** Participate in brainstorming sessions to generate new ideas and solve problems. *Met by group discussion.*

**D Basic and Practical Skills – Reading**

- D.01** Read and apply various sources of technical information (e.g. manufacturer literature, codes, and regulations). *Met by research and preparation prior to group discussion.*

**E Basic and Practical Skills – Proficiency in Mathematics**

- E.01** Determine if a solution is reasonable.
- E.02** Demonstrate ability to use a simple electronic calculator.
- E.05** Solve problems and [sic] make applications involving integers, fractions, decimals, percentages, and ratios using order of operations.
- E.06** Translate written and/or verbal statements into mathematical expressions.
- E.09** Read scale on measurement device(s) and make interpolations where appropriate. *Met by DC voltmeter circuit.*
- E.12** Interpret and use tables, charts, maps, and/or graphs.
- E.13** Identify patterns, note trends, and/or draw conclusions from tables, charts, maps, and/or graphs.
- E.15** Simplify and solve algebraic expressions and formulas.
- E.16** Select and use formulas appropriately.
- E.17** Understand and use scientific notation.

**F Additional Skills – Electromechanics**

- B.01e** Types of motors.

---

**Common areas of confusion for students**

---

**Difficult concept:** *Right-hand rule versus left-hand rule.*

This is an unnecessary difficulty brought on by the disagreement in convention describing electric current. Some textbooks use "conventional flow" notation where current is shown moving from the positive terminal of a source to the negative terminal of a source. With conventional flow notation, the relationship between current and magnetic field direction is described by the right-hand rule. Other textbooks use "electron flow" notation, where the actual motion of electrons in a conductor is the assumed direction for current. In this convention, current moves from the negative terminal of a source to the positive terminal, with the left-hand rule describing how a magnetic field relates to the current.

Which one is correct? With metallic conductor circuits (which is nearly every practical circuit), electron flow notation is actually the most accurate description of charge carrier motion. However, there are reasons why conventional flow notation (and the right-hand rule) is considered more "mathematically" correct, which is why engineers tend to use it. This is especially the case when studying electromagnetism in depth, where the right-hand rule is revealed to be a specific application of the general mathematical rule for *vector cross-products*, and where a "left-hand rule" would go against all mathematical convention with regard to vectors.

In short, either rule will yield the correct results, so long as you are consistent in your conventions! In other words, if you consistently stick with conventional flow and the right-hand rule, you will not go wrong. Or, if you consistently stick with electron flow and the left-hand rule, you will not go wrong. You may get yourself into trouble, though, if you try to switch back and forth between the two different notations for current. My personal recommendation is to go with conventional flow notation and the right-hand rule, because most technical literature is written by and for engineers who predominantly use this. Later on in your study of electronics you will see that all semiconductor device symbols were invented with conventional flow notation in mind, their arrows always pointing in that direction.

Another factor complicating this subject is the presence of similar rules invented to help simplify motor and generator operation, which in fact do not follow the conventions used in physics to relate electric current and magnetism at all. Popularized in U.S. Navy publications, and called the "left-hand rule for generators" and the "right hand rule for motors," these rules switch the ordering of magnetic flux and current direction for the index and middle fingers, and use the thumb to represent direction of motion rather than direction of force as the real vector cross-product relationship goes. The choice to have the thumb point in the direction of motion rather than the direction of force is why they have to use two different rules, one for generators and one for motors. If you maintain the conventions used in physics where the index finger represents current, the middle finger represents magnetic flux, and the thumb points in the direction of *force* (not motion!), one rule will describe all scenarios, generators and motors alike. The existence of two different rules (one for generators and one for motors) is a classic example of how over-simplification actually leads to confusion.

**Difficult concept:** *Rates of change.*

When studying electromagnetic induction and Lenz's Law, one must think in terms of how fast a variable is changing. The amount of voltage induced in a conductor is proportional to how *quickly* the magnetic field changes, not how strong the field is. This is the first hurdle in calculus: to comprehend what a rate of change is, and it is not obvious.

The best examples I know of to describe rates of change are *velocity* and *acceleration*. Velocity is nothing more than a rate of change of position: how quickly one's position is changing over time. Therefore, if the variable  $x$  describes position, then the derivative  $\frac{dx}{dt}$  (rate of change of  $x$  over time  $t$ ) must describe velocity. Likewise, acceleration is nothing more than the rate of change of velocity: how quickly velocity changes over time. If the variable  $v$  describes velocity, then the derivative  $\frac{dv}{dt}$  must describe velocity. Or, since we know that velocity is itself the derivative of position, we could describe acceleration as the *second derivative* of position:  $\frac{d^2x}{dt^2}$

**Difficult concept:** *Thévenin's and Norton's Theorems.*

These two theorems are used to simplify complex circuit networks so that you may mathematically analyze them easier. Two major concepts are difficult here. First is the concept of *equivalent networks*. This is where we take a complex bunch of interconnected components and model them as a much simpler circuit that behaves in the same manner. Understanding that it is possible for a simple circuit to behave identically to a larger, more complex circuit is not intuitive. Naturally, we expect more complex things to have more complex behaviors. However, both Thévenin's and Norton's theorems exploit the fact that certain types of circuits may indeed be greatly simplified and still maintain their original behaviors.

The second major hurdle for students is seeing where these Theorems are actually useful. Here is where many textbooks fail in their presentation of these theorems: by showing the steps of Thévenin's and Norton's theorems only as a prelude to future applications. Indeed, while these theorems are extremely useful in analyzing the transistor circuits you will encounter later on in your studies, it is a mistake to assume there are no immediate, useful applications which you may understand right away. Hopefully the questions contained in this worksheet will allow you to comprehend some of these immediate applications.

**Common mistake:** *Misunderstanding the Maximum Power Transfer Theorem.*

At first, this theorem appears to be very simple: maximum power will be dissipated at the load when the load resistance is equal to the source circuit's equivalent Thévenin or Norton resistance. However, many students misunderstand the scope of this theorem. What it is really saying is that power will be maximized at the load when  $R_{load} = R_{Thevenin}$ , *if  $R_{load}$  is the only resistance you have the freedom to change*. If  $R_{load}$  happens to be fixed, but you have the freedom to change the source circuit's internal resistance, then maximum load power will be achieved when  $R_{Thevenin}$  is equal to zero!

Another misconception is that this theorem tells you when optimum power *efficiency* is reached. In fact, when  $R_{load} = R_{Thevenin}$ , the system efficiency is only 50%. Exactly half of the total source power will be wasted, with only half getting to the load! Maximum *efficiency* is actually reached when the load resistance is very large compared to the source resistance, but of course the actual amount of load power (measured in watts) will be much less than if the load resistance were closer in value to  $R_{Thevenin}$ .

The best way to wrap your mind around all these concepts is to draw a two-resistor, one-battery circuit and do lots of sample calculations for load resistor power, seeing for yourself what happens as the different resistor values change. Approach this scientifically: do a lot of calculations changing only one resistor at a time. Make sure you do enough calculations where you can see the trend of how that one resistor's value affects load power before you decide to change the other resistor's value. Changing only one variable at a time in a scientific test is very important. Otherwise, it will be difficult (or impossible) to tell *what* what is causing what to happen.

---

### Question 1

A *permanent magnet* is a device that retains a magnetic field without need for a power source. Though many of us have experienced the effects of magnetism from a permanent magnet, very few people can describe what *causes* permanent magnetism. Explain the cause of permanent magnetism, in your own words.

file 00173

---

### Answer 1

Magnetism is caused by electric charges in motion. Since electrons in atoms are known to move in certain ways, they are able to produce their own magnetic fields. In some types of materials, the motions of atomic electrons are easily aligned with respect to one another, causing an overall magnetic field to be produced by the material.

Follow-up question: what does the term *retentivity* mean, in relation to permanent magnetism?

---

### Notes 1

The answers students find to this question may be philosophically unsatisfying. It is one thing to discover that magnetism is produced by moving electric charges, but quite another to discover (much less explain) just *what* a magnetic field is in an ontological sense. Sure, it is easy to explain what magnetic fields *do*, or even how they relate to other phenomenon. But what, exactly, *is* a magnetic field? This question is on the same level as, "what is an electric charge?"

---

Question 2

If we were to trace the magnetic lines of flux extending from this bar magnet, what would they appear like?

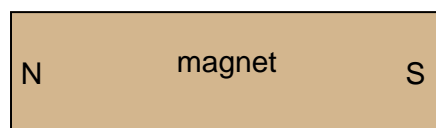

file 00623

---

Answer 2

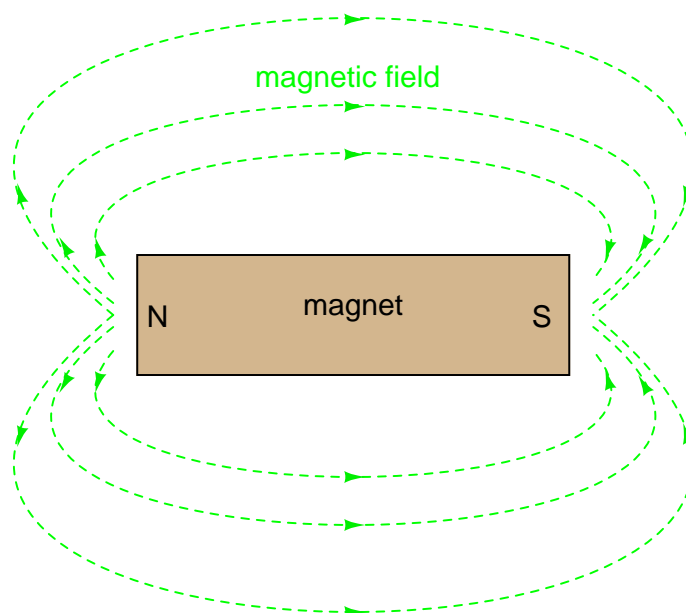

Challenge question: design an experiment to reveal the patterns of magnetic flux lines in visual form.

---

Notes 2

Experiments designed to reveal the patterns of magnetic flux lines are easy to set up. Try to have some iron filings, and some powerful bar magnets, available in your class for this purpose!

---

### Question 3

Magnetic poles are designated by two labels: "North" and "South". How are these labels defined? Explain how we can experimentally determine which ends of a magnet are "North" and "South", respectively?  
[file 00626](#)

---

### Answer 3

The end of a magnet that points to the north pole of the Earth is called the "North" pole of the magnet.

---

### Notes 3

After your students explain how to experimentally determine the poles of a magnet, challenge them with this question: given that like poles repel and opposite poles attract, what are the proper magnetic pole designations for the Earth's actual poles? If the "north" end of a bar magnet orients itself so that it is geographically pointing north, what "magnetic polarity" does the actual North pole of the Earth have?

---

Question 4

Devise a method of identifying the poles of a magnet that is too large and heavy to move.  
[file 00629](#)

---

Answer 4

I'll give you a hint: you could use another magnet!

---

Notes 4

This is another question designed to provoke students to think creatively in problem-solving. They should already understand the principle of suspending a magnet and using the Earth's natural magnetic field to identify the magnet's poles. However, this requires allowing the magnet to freely rotate (hence the requirement of suspension) so it can act as a compass. Using the same process to identify the poles of an immovable magnet may require the use of an intermediary magnet, combined with the knowledge of magnet pole interactions (repulsion versus attraction).



---

Question 5

What happens to the magnetic lines of flux emanating from a magnet, when an unmagnetized piece of iron is placed near it?

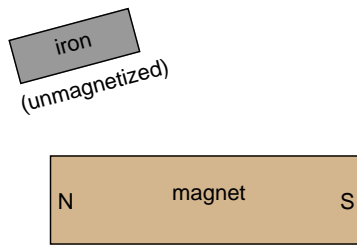

file 00625

---

Answer 5

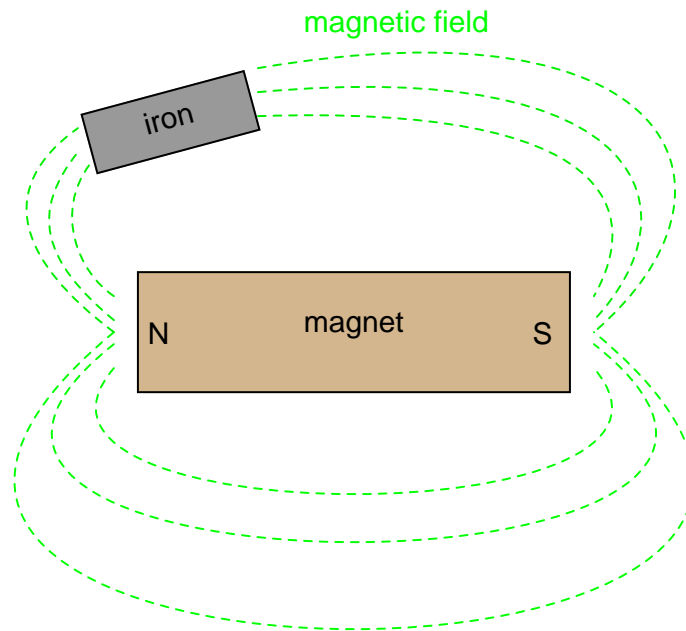

Challenge question: can you think of any practical applications of this field-distortion effect?

---

Notes 5

A previously unmagnetized piece of iron will become magnetized once exposed to the magnetic field of a nearby magnet. This fact leads to another question, namely, what magnetic pole assignments does the iron piece assume in this condition? Ask your students to identify which end of the iron becomes "North" and which end of the iron becomes "South".

One application of magnetic field distortion is the remote detection of vehicles and other objects made of ferrous metals. There is an historical wartime application of this principle, which may prove interesting for discussion purposes!

Question 6

In electric circuits, the three basic quantities are *voltage* ( $E$  or  $V$ ), *current* ( $I$ ), and *resistance* ( $R$ ), corresponding to the general concepts of *cause*, *effect*, and *opposition*, respectively.

$$I = \frac{E}{R}$$

$$\text{effect} = \frac{\text{cause}}{\text{opposition}}$$

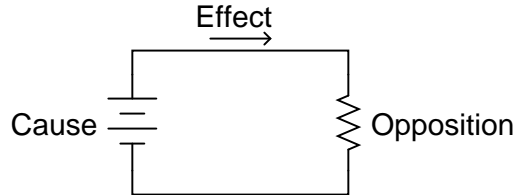

Magnetic "circuits" also have quantities corresponding to "cause," "effect," and "opposition." Identify these quantities, along with their respective symbols, and write an "Ohm's Law" equation relating them mathematically. Also, identify the units of measurement associated with each, in three systems of measurement: CGS ("old" metric), SI ("new" metric), and English.

*Magnetic "circuit"*

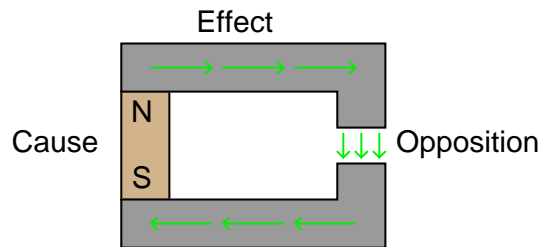

file 00678

---

Answer 6

"Cause" = Magnetomotive force (MMF) =  $\mathcal{F}$

"Effect" = Magnetic flux =  $\Phi$

"Opposition" = Reluctance =  $\mathfrak{R}$

This relationship is known as *Rowland's Law*, and it bears striking similarity to Ohm's Law in electric circuits:

$$\Phi = \frac{\mathcal{F}}{\mathfrak{R}}$$

Quantity	Symbol	Unit of Measurement and abbreviation		
		CGS	SI	English
Field Force	$\mathcal{F}$	Gilbert (Gb)	Amp-turn	Amp-turn
Field Flux	$\Phi$	Maxwell (Mx)	Weber (Wb)	Line
Reluctance	$\mathfrak{R}$	Gilberts per Maxwell	Amp-turns per Weber	Amp-turns per line

Follow-up question: algebraically manipulate the Rowland's Law equation shown above to solve for  $\mathcal{F}$  and to solve for  $\mathfrak{R}$ .

---

Notes 6

Magnetism, while commonly experienced in the form of permanent magnets and magnetic compasses, is just as "strange" a concept as electricity for the new student. At this point in their education, however, they should be familiar enough with voltage, current, and resistance to reflect upon them as analogous quantities to these new magnetic quantities of MMF, flux, and reluctance. Emphasize the analogical similarities of basic electrical quantities in your discussion with students. Not only will this help students understand magnetism better, but it will also reinforce their comprehension of electrical quantities.

---

Question 7

If we were to graph the "response" of a resistor to various levels of applied voltage, we would obtain a plot that looks like this:

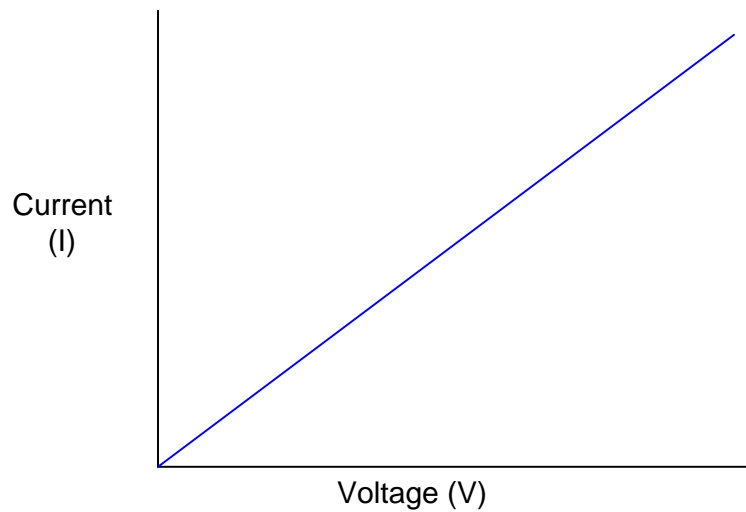

If we were to graph the "response" of a ferromagnetic sample to various levels of applied magnetomotive force, we would obtain a plot that looks something like this:

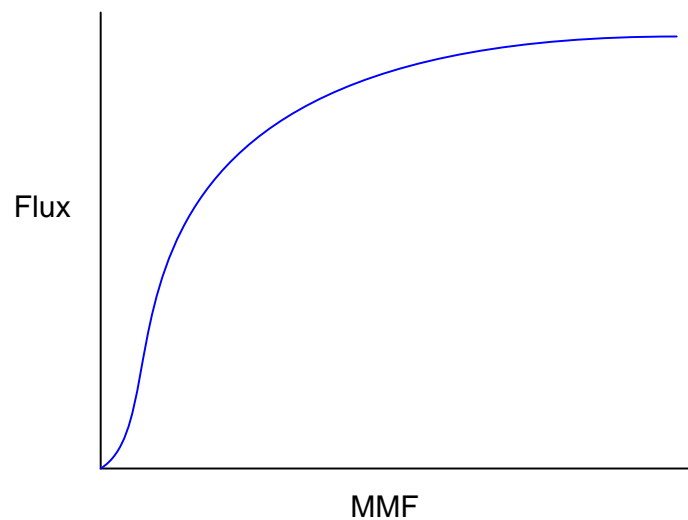

What does this graph indicate to you, as compared to the graph for a resistor's characteristics? What is the significance of this with regard to magnetic "circuit" analysis?

[file 00682](#)

---

Answer 7

The MMF/flux plot for a ferromagnetic material is quite *nonlinear*, unlike the plot for an electrical resistor.

Ask your students to identify *resistance* on the V/I graph shown in the question. Where on that graph is resistance represented? Your more mathematically astute students will recognize (or perhaps recall from earlier discussions) that the slope of the plot indicates the resistance of the circuit. The less resistance, the steeper the plot (at least in this case, where current is on the vertical axis and voltage on the horizontal). At any point on the plot, the slope is the same, indicating that resistance does not change over a wide range of voltage and current.

Now, direct their attention to the MMF/flux graph. Where is *reluctance* indicated on the graph? What conclusion may we form regarding reluctance in a magnetic circuit, from analyzing the shape of the MMF/flux curve shown? At what point is reluctance the greatest? At what point is it the least?

---

Question 8

When lightning strikes, nearby magnetic compass needles may be seen to jerk in response to the electrical discharge. No compass needle deflection results during the accumulation of electrostatic charge preceding the lightning bolt, but only when the bolt actually strikes. What does this phenomenon indicate about voltage, current, and magnetism?

[file 00077](#)

---

Answer 8

The presence of an electric current will produce a magnetic field, but the mere presence of a voltage will not. For more detail on the historical background of this scientific discovery, research the work of Hans Christian Oersted in the early 1820's.

---

Notes 8

The discovery of electromagnetism was nothing short of revolutionary in Oersted's time. It paved the way for the development of electric motors, among other useful electrical devices.

---

### Question 9

In 1820, the French physicist André Marie Ampère discovered that two parallel wires carrying electrical current would either be attracted to one another, or repelled by one another, depending on what directions the two currents were going. Devise an experiment to reproduce Ampère's results, and determine which directions current must go to produce an attractive versus a repulsive force.

[file 00170](#)

---

### Answer 9

I won't indicate the answer here, as the whole point of the question is to stimulate you to design and operate an experiment. Let the facts themselves give you the answer!

---

### Notes 9

This experiment is well worth performing during discussion time with your students. There are several ways to demonstrate the effect of electromagnetism in the way that Ampère did back in 1820. It will be interesting to compare your students' different approaches to this experiment.

One of the habits you should encourage in your students is experimentation to discover or confirm principles. While researching other peoples' findings is a valid mode to obtaining knowledge, the rewards of primary research (i.e. direct experimentation) are greater and the results more authoritative.

Another point you might want to mention here is the problem-solving technique of *altering the problem*. Instead of envisioning two *straight* parallel wires, imagine those wires being bent so they form two parallel *coils*. Now the right-hand rule applies for determining magnetic polarity, and the question of attraction versus repulsion is more easily answered.

---

Question 10

Draw the pattern of the magnetic field produced by electric current through a straight wire and through a wire coil:

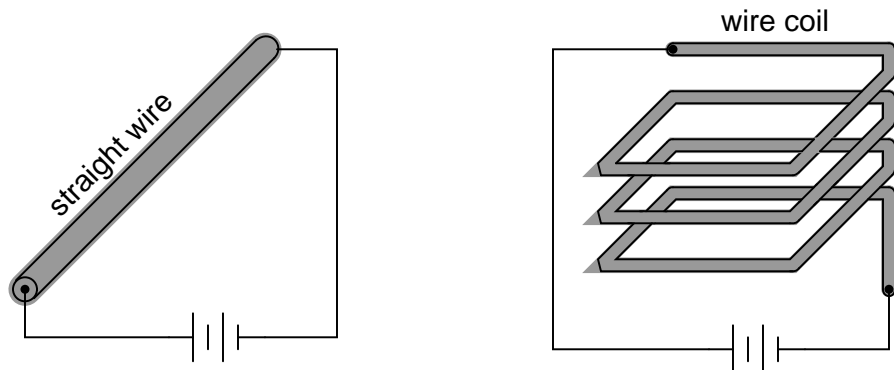

Explain your answer using either the *right-hand rule* (conventional flow) or the *left-hand rule* (electron flow).

[file 00175](#)

---

Answer 10

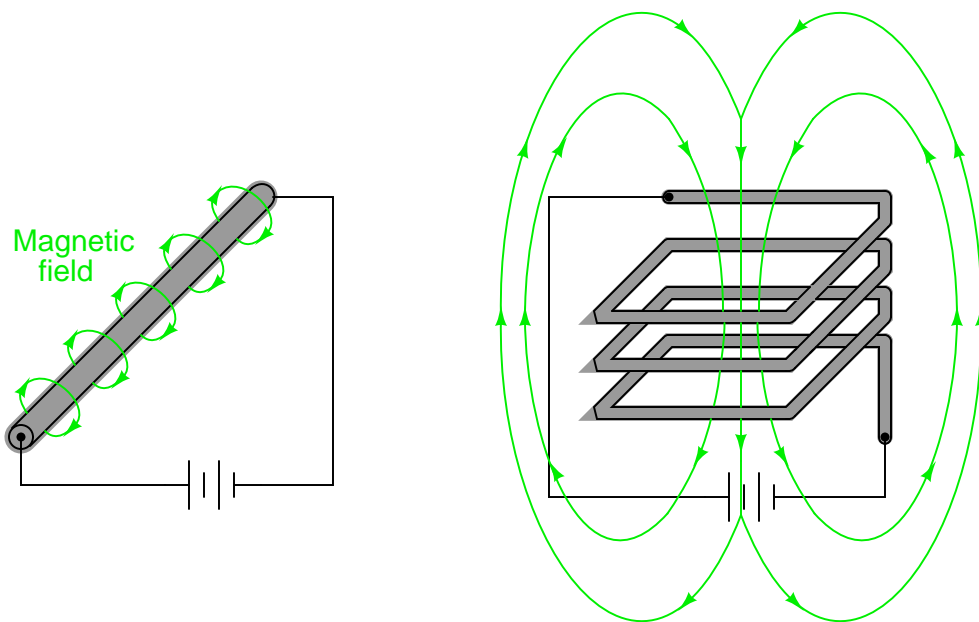

---

Notes 10

In your students' research, they will encounter a "right-hand rule" as well as a "left-hand rule" for relating electric current with magnetic field directions. The distinction between the two rules depends on whether the text uses "conventional flow" notation or "electron flow" notation to denote the movement of electrical charge through the conductors. Sadly, this is another one of those concepts in electricity that has been made unnecessarily confusing by the prevalence of two "standard" notions for electric current.



---

Question 11

Suppose that a length of electrical wire is wrapped around a section of an iron torus, and electric current conducted through the wire:

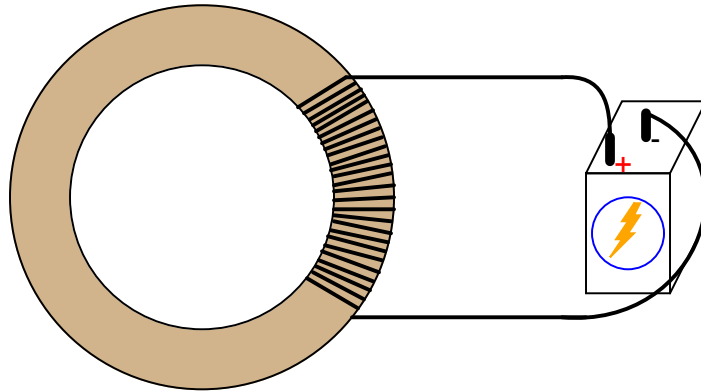

What factors influence the amount of MMF, flux, and reluctance in this magnetic "circuit"?  
[file 00679](#)

---

Answer 11

MMF is determined by the amount of current through the wire coil, and the number of turns in the coil ( $\mathcal{F} = IN$ ). Reluctance is determined by the cross-sectional area of the magnetic flux path, the length of that path, the type of material the torus is made of, *and the amount of flux present in the torus*. Magnetic flux is determined by the MMF and reluctance.

Follow-up question: how similar are these relationships to voltage, resistance, and current in an electrical circuit? Note any similarities as well as any differences.

---

Notes 11

Perhaps the most interesting part of the answer to this question is that magnetic reluctance ( $\mathfrak{R}$ ) changes with the amount of flux ( $\Phi$ ) in the "circuit". At first, this may seem quite different from electrical circuits, where resistance ( $R$ ) is constant regardless of current ( $I$ ).

However, the constancy of electrical resistance is something easily taken for granted. Ask your students to think of electrical devices (or phenomena) where resistance is not stable over a wide range of currents. After some discussion, you should find that the phenomenon of constant resistance is not as common as one might think!

After students have grasped this concept, ask them what it means with regard to magnetic flux ( $\Phi$ ) versus MMF ( $\mathcal{F}$ ). In other words, what happens to flux in a magnetic circuit as MMF is increased?

---

### Question 12

A coil of wire is formed of many loops. These loops, though tracing a circular path, may be thought of as being parallel to each other. We know that whenever two parallel wires carry an electric current, there will be a mechanical force generated between those two wires (as in André Marie Ampère's famous experiment).

When electric current is passed through a coil of wire, does the inter-loop force tend to compress the coil or extend it? Explain your answer.

[file 00627](#)

---

### Answer 12

The coil will tend to compress as current travels through its loops.

Challenge question: what will happen to a wire coil if *alternating* current is passed through it instead of direct current? Will the coil compress, extend, or do something entirely different?

---

### Notes 12

Questions such as this require the student to visualize a "bent" version of a phenomenon defined in terms of straight wires (Ampère's experiment). Some students, of course, will have a much more difficult time visualizing this than others. For those that struggle with this form of problem-solving, spend some discussion time on problem-solving (visualization) techniques to help those who find this difficult to do. Is there a particular drawing, sketch, or analogy that other students have found useful in their analysis of the problem?

The challenge question regarding alternating current is meant to be a "trick" question of sorts. The "unthinking" answer is that with alternating current, there will be a force that alternates direction: repulsion one half-cycle, then attraction for the next half-cycle. You may find students divided on this assessment, some thinking there will an alternating force, while others think the force will remain in the same direction at all times. There is one sure way to prove who is correct here: set up an experiment with AC power and see for yourself (straight, parallel wires will work just fine for this)!

---

**Question 13**

Two important variables in magnetic circuit analysis are  $B$  and  $H$ . Explain what these two variables represent, in terms of the more fundamental magnetic quantities of MMF ( $\mathcal{F}$ ) and flux ( $\Phi$ ), and relate them, if possible, to electrical quantities. Also, determine the units of measurement for these two variables, in the CGS, SI, and English measurement systems.

file 00681

---

**Answer 13**

Quantity	Symbol	Unit of Measurement and abbreviation		
		CGS	SI	English
Field Intensity	H	Oersted (Oe)	Amp-turns per meter	Amp-turns per inch
Flux Density	B	Gauss (G)	Tesla (T)	Lines per square inch

Field intensity ( $H$ ) is also known as "magnetizing force," and is the amount of MMF per unit length of the magnetic flux path. Flux density ( $B$ ) is the amount of magnetic flux per unit area.

---

**Notes 13**

Although the equivalent electrical variables to field intensity and flux density are not commonly used in electronics, they do exist! Ask your students if anyone was able to determine what these variables are. Also, ask them where they were able to obtain the information on magnetic quantities and units of measurement.

You should mention to your students that the SI units are considered to be the most "modern" of those shown here, the SI system being the international standard for metric units in all applications.

---

#### Question 14

When a steel manufacturer publishes the magnetic characteristics of their latest alloy, they do so in the form of a "B/H" graph, where flux density ( $B$ ) is plotted as a function of magnetizing force ( $H$ ):

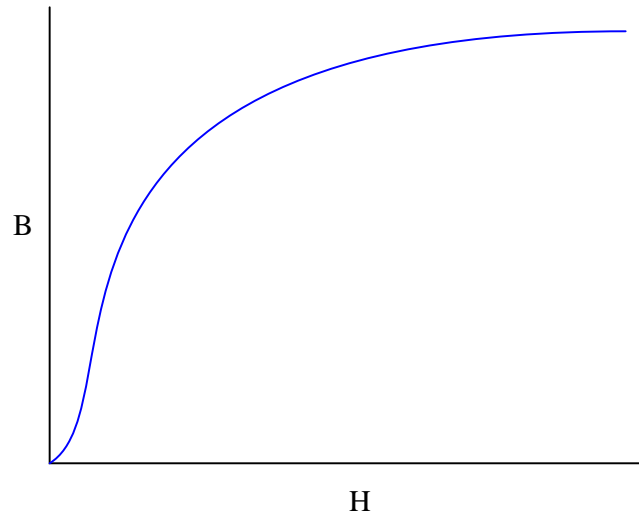

Rarely will you see a plot of flux ( $\Phi$ ) shown as a function of MMF ( $\mathcal{F}$ ), even though such a plot would appear very similar to the "B/H curve" for that same material. Why is this? Why would a "B/H" curve be preferable to an engineer rather than a "Flux/MMF" curve?

Hint: if a copper manufacturer were to publish the electrical characteristics of their latest alloy, they would specify its resistivity in terms of specific resistance ( $\rho$ ), rather than plain resistance ( $R$ ), for the exact same reason!

[file 00683](#)

---

#### Answer 14

A "B/H curve" is independent of the specimen's physical dimensions, communicating the magnetic characteristics of the *substance* itself, rather than the characteristics of any one particular *piece* of that substance.

---

#### Notes 14

This concept may confuse some students, so discussion on it is helpful. Ask your students what "flux density" and "magnetizing force" really mean: they are expressions of flux and MMF *per unit dimension*. So, if a manufacturer states that their new steel alloy will permit a flux density of 0.6 Tesla for an applied magnetizing force of 100 amp-turns/meter, this figure holds true for *any* size chunk of that alloy.

To prove this concept via the rhetorical technique of *reductio ad absurdum*, ask your students what it would be like if copper manufacturers specified the resistivity of their copper alloys in ohms: "Alloy 123XYZ has a resistivity of 17 ohms." Of what usefulness is this statement? What does it mean to us? How is the statement, "Alloy 123XYZ has a resistivity of 10.5 ohm-cmil per foot," superior?

---

Question 15

Explain what this graph means, and how it represents both *saturation* and *hysteresis* as magnetic phenomena:

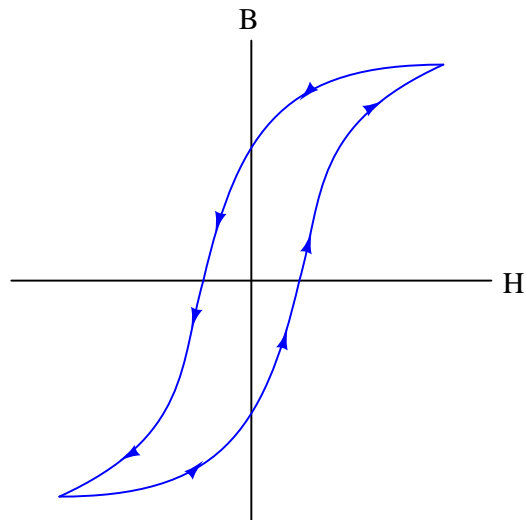

file 00472

---

Answer 15

This is a  $B-H$  curve, plotting the magnetic flux density ( $B$ ) against the magnetic field intensity ( $H$ ) of an electromagnet. The arrowheads represent the directions of increase and decrease in the variables.

"Saturation" is when  $B$  changes little for substantial changes in  $H$ . There are two regions on the  $B-H$  curve where saturation is evident.

---

Notes 15

This question is worthy of much discussion. It is one thing to recognize this curve as being a  $B-H$  curve, and quite another to explain exactly what it means. Ask your students to show on the curve, for instance, what happens when an electromagnet is fully energized with DC, and then the current is shut off, leaving a residual flux in the core. What is necessary to de-magnetize the core once again?

Also be sure to discuss saturation in detail. This is a very important magnetic phenomenon, without a direct analogy in electric circuits (it is not as though wires "saturate" when carrying too much current!).

---

Question 16

Given the following equations, derive a single equation expressing permeability ( $\mu$ ) in terms of flux density ( $B$ ) and field intensity ( $H$ , otherwise known as magnetizing force):

$$\mathfrak{R} = \frac{\mathcal{F}}{\Phi}$$

$$\mathfrak{R} = \frac{l}{\mu A}$$

$$H = \frac{\mathcal{F}}{l}$$

$$B = \frac{\Phi}{A}$$

file 00685

---

Answer 16

$$\mu = \frac{B}{H}$$

---

Notes 16

This question is an exercise in algebraic substitution and manipulation. It might be a good idea to point out that the following equation is valid only for a "solenoid" (a coil of wire).

$$\mathfrak{R} = \frac{l}{\mu A}$$

In the case of an air-core solenoid, the formula is as follows:

$$\mathfrak{R} = \frac{l}{\mu_0 A}$$

Where,

$l$  = linear length of coil in meters (m)

$A$  = cross-sectional area of coil "throat" in square meters ( $\text{m}^2$ )

$\mu_0$  = permeability of free space =  $4\pi \times 10^{-7}$  (T·m/A)

---

Question 17

Which magnet motion past the wire will produce the greatest voltmeter indication: perpendicular, parallel, or no motion at all?

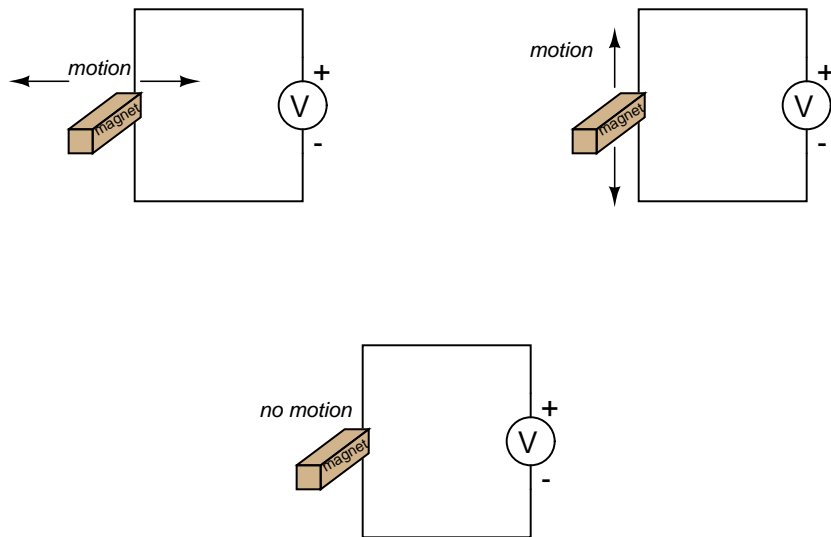

[file 00174](#)

---

Answer 17

The answer to this question is easy enough to determine experimentally. I'll let you discover it for yourself rather than give you the answer here.

Hint: the voltage generated by a magnetic field with a single wire is quite weak, so I recommend using a very sensitive voltmeter and/or a powerful magnet. Also, if the meter is analog (has a moving pointer and a scale rather than a digital display), you must keep it far away from the magnet, so that the magnet's field does not directly influence the pointer position.

Follow-up question: identify some potential problems which could arise in this experiment to prevent induction from occurring.

---

Notes 17

This is another one of those concepts that is better learned through experimentation than by direct pronouncement, especially since the experiment itself is so easy to set up.

---

Question 18

$\int f(x) dx$  *Calculus alert!*

The relationship between magnetic flux and induced voltage in a wire coil is expressed in this equation, known as *Faraday's Law*:

$$e = N \frac{d\phi}{dt}$$

Where,

$e$  = Instantaneous induced voltage, in volts

$N$  = Number of turns in wire coil

$\phi$  = Instantaneous magnetic flux, in webers

$t$  = Time, in seconds

Explain what the mathematical expression  $\frac{d\phi}{dt}$  means, in light of what you know about electromagnetic induction. Hint: the  $\frac{d}{dt}$  notation is borrowed from calculus, and it is called the *derivative*.

Also, explain why lower-case letters are used ( $e$  instead of  $E$ ,  $\phi$  instead of  $\Phi$ ) in this equation.

[file 00256](#)

---

Answer 18

The mathematical expression  $\frac{d\phi}{dt}$  means "rate of change of magnetic flux over time." In this particular example, the unit would be "webers per second."

The use of lower-case letters for variables indicates *instantaneous* values: that is, quantities expressed in terms of instantaneous moments of time.

Follow-up question: manipulate this equation to solve for each variable ( $\frac{d\phi}{dt} = \dots$ ;  $N = \dots$ ).

---

Notes 18

For students who have never studied calculus, this is an excellent opportunity to introduce the concept of the derivative, having already established the principle of induced voltage being related to how *quickly* magnetic flux changes over time. In general physics studies, the quantities of position, velocity, and acceleration are similarly used to introduce the concept of the time-derivative, and later, the time-integral. In electricity, though, we have our own unique applications!



---

Question 19

If a wire coil with 450 turns is exposed to a magnetic flux increasing at a rate of 0.008 Webers per second, how much voltage will be induced across the coil?

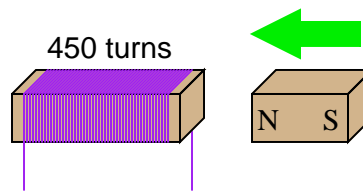

[file 01983](#)

---

Answer 19

3.6 volts

---

Notes 19

This is simply a quantitative application of Faraday's Law. There is no significance to the fact that the magnetic flux is increasing rather than decreasing. The only effect this would have on the induced voltage is its polarity.

---

Question 20

How many turns of wire must a coil have in order to induce a voltage of 10.5 volts when exposed to a changing magnetic flux with a rate of 0.0075 Wb/s?

file 01984

---

Answer 20

1400 turns

---

Notes 20

This is nothing but a quantitative application of Faraday's Law, after algebraic manipulation to solve for  $N$ .

---

Question 21

If the motion of a conductor through a magnetic field induces a voltage in that conductor, it stands to reason that a conductive fluid moving through a pipe can also generate a voltage, if properly exposed to a magnetic field. Draw a picture showing the necessary orientation of the pipe, the magnetic field, and the electrodes intercepting the induced voltage.

file 00260

---

Answer 21

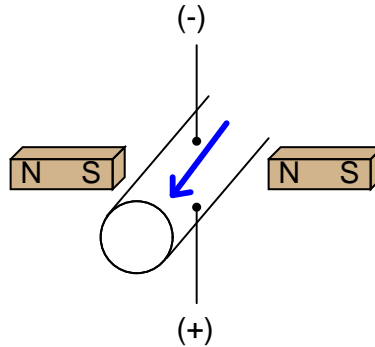

---

Notes 21

This question really tests students' comprehension of the orthogonal relationships between magnetic flux, conductor motion, and induced voltage. Additionally, it reveals a novel method of producing electricity: *magnetohydrodynamics*.

There are a few interesting applications of magnetohydrodynamics, including power generation and flow measurement. Discuss these with your students if time permits.

---

Question 22

Cranes used to move scrap iron and steel use electrically powered magnets to hold the metal pieces, rather than a scoop or some other mechanical grasping device:

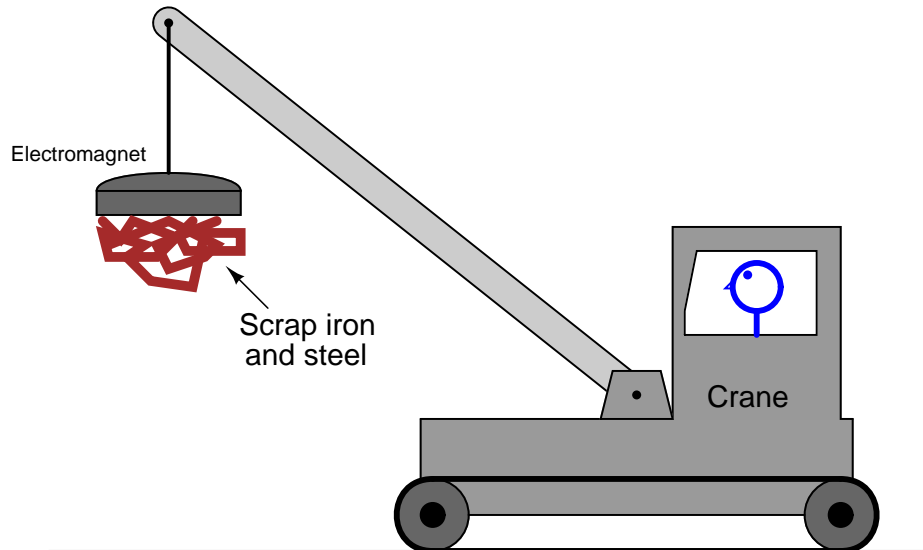

In this illustration of a crane, superimpose a drawing showing the electromagnet, electrical power supply and wiring necessary for this to work. Also include a switch so the crane operator can turn the magnet on and off. Also, draw an electrical schematic diagram of the same circuit, showing all components in the crane's magnet circuit.

[file 00171](#)

---

Answer 22

Here is my schematic diagram:

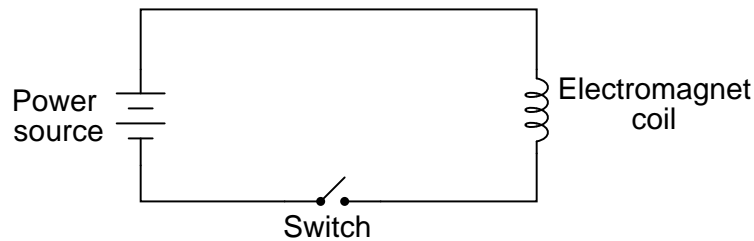

I will leave it to you to draw the illustration of this circuit on the crane. Your answer should show a wire *coil* embedded in the electromagnet assembly, a switch symbol near the operator, a battery symbol for the power supply, and wires carrying current to and from the electromagnet coil.

---

Notes 22

The main purpose of this question is to have the students relate the principles of electric circuits and electromagnetism to a real-life application, and to show how the wire paths in the crane do not resemble the neat, clean layout of the schematic diagram.

---

Question 23

A *solenoid valve* uses magnetism from an electromagnet coil to actuate a valve mechanism:

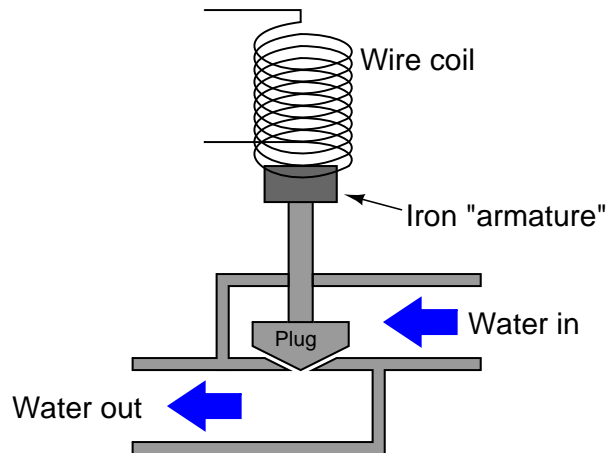

Essentially, this is an electrically-controlled on/off water valve. In the development of this valve, though, the design engineers discover that the magnetic force produced by the electromagnet coil is not strong enough to achieve reliable valve actuation every time. What can be changed in this solenoid valve design to produce a greater actuating force?

[file 00172](#)

---

Answer 23

Here are a few ways in which the strength of the magnetic field may be increased: pass a greater electrical current through the coil, use more turns of wire in the coil, or accentuate the field strength using better or larger magnetic core materials. These are not the only ways to increase the mechanical force generated by the action of the magnetic field on the iron armature, but they are perhaps the most direct.

Follow-up question: suppose this valve did not open like it was supposed to when the solenoid coil was energized. Identify some possible reasons for this type of failure.

---

Notes 23

The fundamental question here is, "what factors influence the strength of an electromagnetically-generated magnetic field?" It is easy to research the effects of coil dimensions, core materials, current levels, etc. What students need to do in this question is *apply* those techniques to this real-life scenario.

Be sure to spend time on the follow-up question with your students, considering non-electrical as well as electrical fault possibilities.

---

Question 24

If we were to analyze the magnetic flux lines of a current-carrying conductor, oriented perpendicularly to a magnetic field between two bar magnets, the interaction would look something like this:

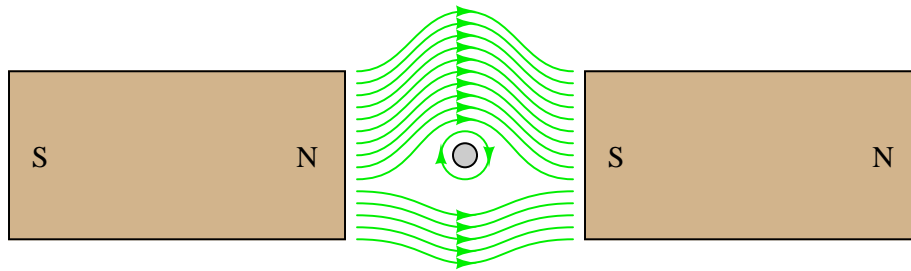

This interaction of magnetic flux lines (the bar magnets' straight lines versus the wire's circles) will produce a mechanical force on the wire (called the *Lorentz force*). Which direction will this force act? Also, determine the direction of current through the conductor (seen from an end-view in the above illustration) necessary to produce the circular magnetic flux shown.

[file 00396](#)

---

Answer 24

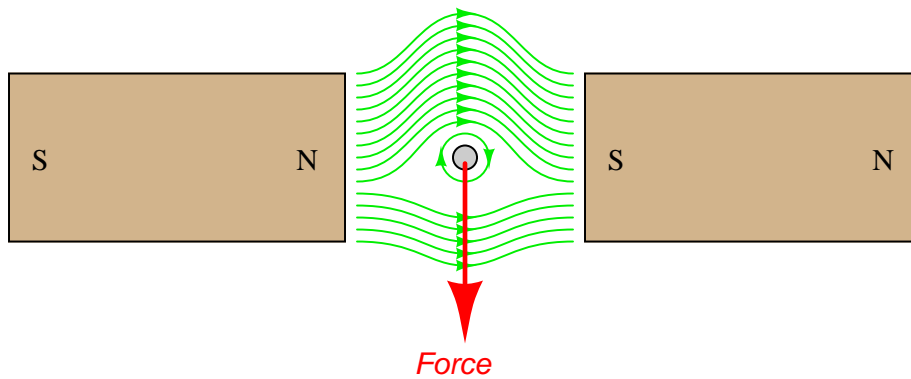

---

Notes 24

This question serves as a good application of the right-hand rule (or left-hand rule, if you follow electron flow notation).

---

Question 25

If current is passed through a loop of wire, as shown, which direction will the loop rotate?

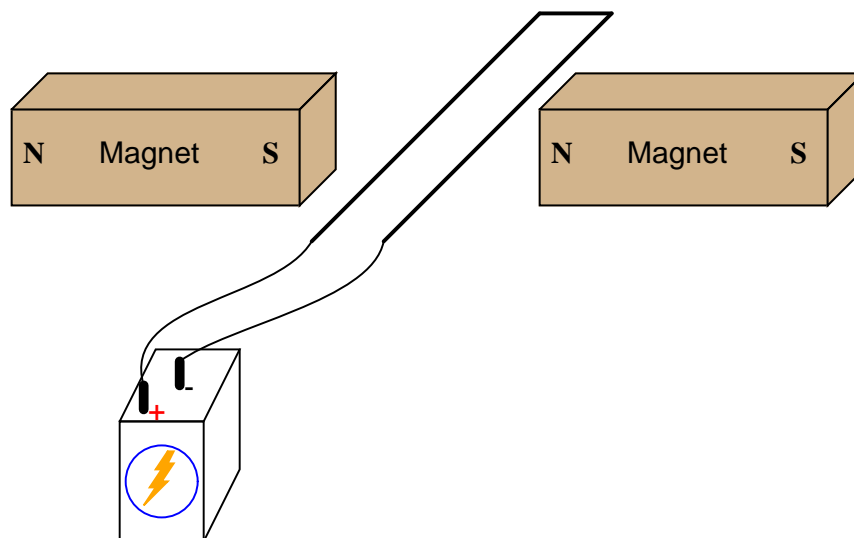

file 00383

---

Answer 25

Clockwise, one-quarter turn (90 degrees).

---

Notes 25

Ask your students to identify the poles of the electromagnetic field produced by this current-carrying wire loop, and then its direction of torque may become easier to understand.

---

Question 26

If the ends of a wire loop are attached to two half-circular metal strips, arranged so that the two strips almost form a complete circle, and those strips are contacted by two "brushes" which connect to opposite poles of a battery, which way will the wire loop rotate?

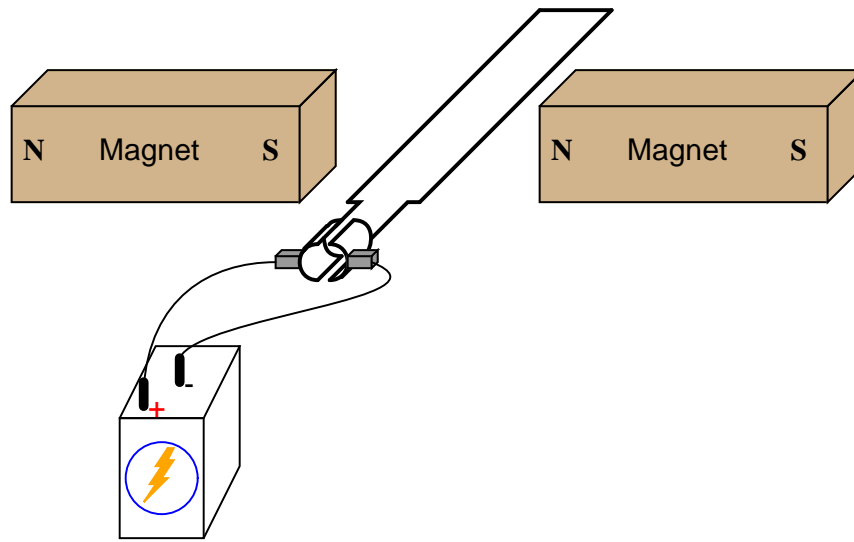

file 00384

---

Answer 26

Clockwise, continuously.

---

Notes 26

Challenge your students with this question: is there any way we can get the wire loop to continuously rotate without using those half-circle metal strips to make and break contact with the battery? Ask your students what the two half-circle metal strips are called, in electric motor/generator terminology.



---

Question 27

A DC motor may be thought of as a series of electromagnets, radially spaced around a common shaft:

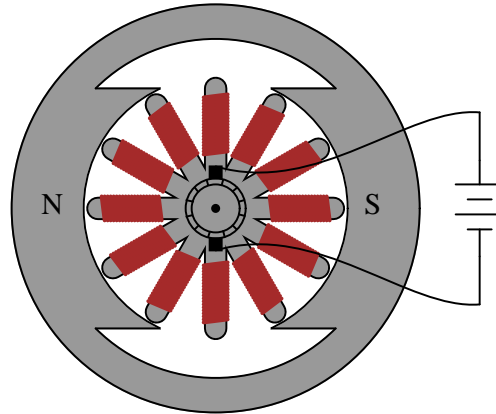

This particular motor is of the "permanent magnet" type, with wire windings only on the armature. Write the necessary magnetic polarities ("N" for north and "S" for south) on the armature's electromagnet pole tips, in order to sustain a *clockwise* rotation.

[file 00394](#)

---

Answer 27

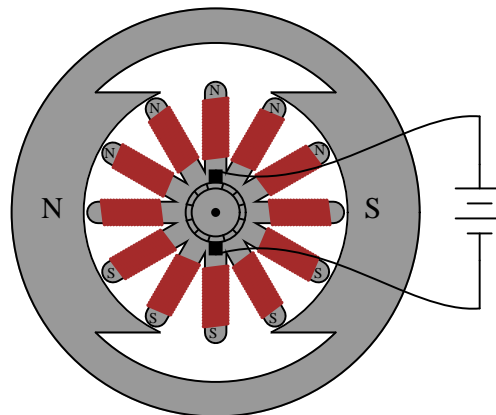

Follow-up question: suppose this motor did not rotate like it was supposed to when energized. Identify some possible (specific) failures that could result in the motor not moving upon energization.

---

Notes 27

The illustration shown in both the question and the answer provides a good medium for discussing commutation. Discuss with your students how, in order for the motor's rotation to be continuous, the electromagnets radially spaced around the shaft must energize and de-energize at the right times to always be "pulling" and "pushing" in the correct direction.

Be sure to spend time on the follow-up question with your students, considering non-electrical as well as electrical fault possibilities.

---

Question 28

Define the following DC motor terms:

- Field
- Armature
- Commutator
- Brush

file 00393

---

Answer 28

- Field: *the portion of the motor creating the stationary magnetic field*
  - Armature: *the rotating portion of the motor*
  - Commutator: *copper strips where the armature coil leads terminate, usually located at one end of the shaft*
  - Brush: *a stationary carbon block designed to electrically contact the moving commutator bars*
- 

Notes 28

Students may find pictures of DC electric motors in their search for these terms' definitions. Have them show these pictures to the class if possible. Also, a disassembled electric motor is a great "prop" for discussion on electric motor nomenclature.

---

Question 29

When a DC motor is running, sparks may generally be seen where the carbon brushes contact the "commutator" segments. Explain why this sparking occurs, and also define the word "commutation" in its electrical usage.

What does this phenomenon indicate about the longevity of DC motors, and their suitability in certain environments?

[file 00385](#)

---

Answer 29

To "commutate" means "to reverse direction," in the electrical sense of the word. The result of the commutator bars and brushes alternately making and breaking the electrical circuit with the armature windings invariably causes some degree of sparking to occur.

Follow-up question: identify an environment where a sparking motor would be unsafe.

---

Notes 29

If your students find themselves working in some sort of electrical maintenance jobs, what types of routine maintenance do they think they might have to do on DC electric motors, given the presence of sparking at the commutator? Ask them what safety issues this sparking could present in certain environments. Ask them if they think there are any environments that would be especially detrimental to a motor design such as this.

---

### Question 30

As the armature coils in a DC motor rotate through the magnetic flux lines produced by the stationary field poles, voltage will be induced in those coils. Describe how this phenomenon relates to Faraday's Law of electromagnetic induction, specifically in regard to what variables influence the magnitude of the induced voltage:

$$e = N \frac{d\phi}{dt}$$

The self-induced voltage produced by a rotating armature is often called the *counter-voltage*, or *counter-EMF*. Why would it be called "counter"? What is implied by this terminology, and what electromagnetic principle is illustrated by the "counter" nature of this induced voltage?

file 00397

---

### Answer 30

Counter-EMF varies directly with armature speed, with the number of turns in the armature windings, and also with field strength. It is called "counter-" EMF because of Lenz' Law: the induced effect opposes the cause.

---

### Notes 30

The principle I wish to communicate most with this problem is that every motor, when operating, also acts as a generator (producing counter-EMF). This concept is essential to understanding electric motor behavior, especially torque/speed curves.

---

Question 31

When the switch closes, the ammeter will initially register a large amount of current, then the current will decay to a much lesser value over time as the motor speeds up:

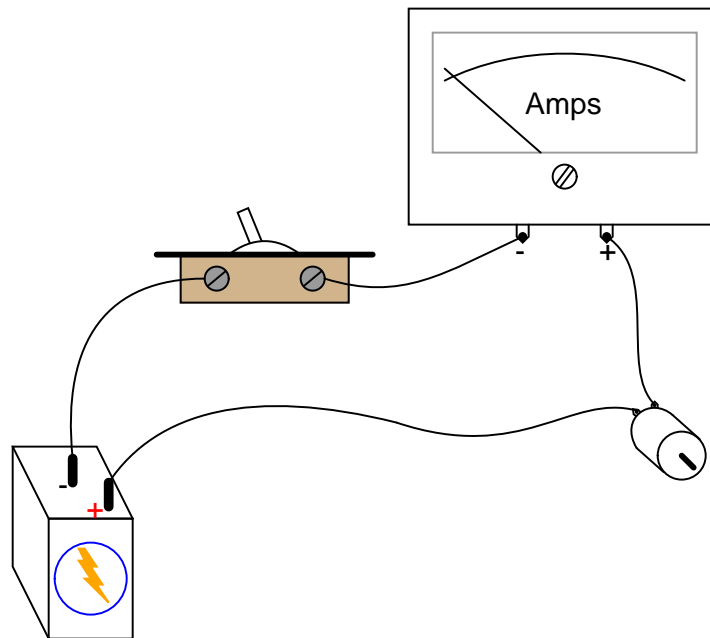

In view of Ohm's Law, where current is supposed to be a direct function of voltage and resistance ( $I = \frac{E}{R}$ ), explain why this happens. After all, the motor's winding resistance does not change as it spins, and the battery voltage is fairly constant. Why, then, does the current vary so greatly between initial start-up and full operating speed?

What do you think the ammeter will register after the motor has achieved full (no-load) speed, if a mechanical load is placed on the motor shaft, forcing it to slow down?

[file 00395](#)

---

Answer 31

Motor current is inversely proportional to speed, due to the counter-EMF produced by the armature as it rotates.

Follow-up question: draw a schematic diagram showing the equivalent circuit of battery, switch, ammeter, and motor, with the counter-EMF of the motor represented as another battery symbol. Which way must the counter-EMF voltage face, *opposed* to the battery voltage, or *aiding* the battery voltage?

---

Notes 31

The so-called "inrush" current of an electric motor during startup can be quite substantial, upwards of ten times the normal full-load current!

---

Question 32

A DC electric motor spinning at 4500 RPM draws 3 amps of current with 110 volts measured at its terminals. The resistance of the armature windings, measured with an ohmmeter when the motor is at rest, unpowered, is 2.45 ohms. How much counter-EMF is the motor generating at 4500 RPM?

How much "inrush" current will there be when the motor is initially powered up (armature speed = 0 RPM), once again assuming 110 volts at the terminals?

file 00398

---

Answer 32

$$E_{counter} = 102.65 \text{ V @ 4500 RPM}$$

$$I_{inrush} = 44.9 \text{ A}$$

---

Notes 32

This calculation helps students realize just how significant the "inrush" current of an electric motor is.

---

### Question 33

A large audio speaker may serve to demonstrate both the principles of *electromagnetism* and of *electromagnetic induction*. Explain how this may be done.

file 00079

---

### Answer 33

I won't tell you how to set up or do the experiment, but I will show you an illustration of a typical audio speaker:

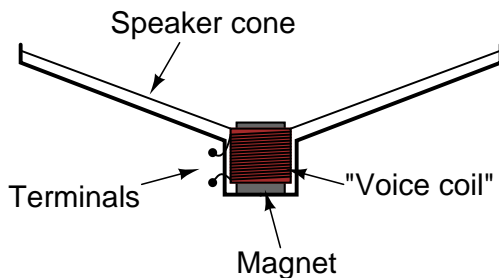

The "voice coil" is attached to the flexible speaker cone, and is free to move along the long axis of the magnet. The magnet is stationary, being solidly anchored to the metal frame of the speaker, and is centered in the middle of the voice coil.

This experiment is most impressive when a physically large (i.e. "woofer") speaker is used.

Follow-up question: identify some possible points of failure in a speaker which would prevent it from operating properly.

---

### Notes 33

Since not everyone has ready access to a large speaker for this kind of experiment, it may help to have one or two "woofer" speakers located in the classroom for students to experiment with during this phase of the discussion. Any time you can encourage students to set up impromptu experiments in class for the purpose of exploring fundamental principles, it is a Good Thing.

---

### Question 34

If a copper ring is brought closer to the end of a permanent magnet, a repulsive force will develop between the magnet and the ring. This force will cease, however, when the ring stops moving. What is this effect called?

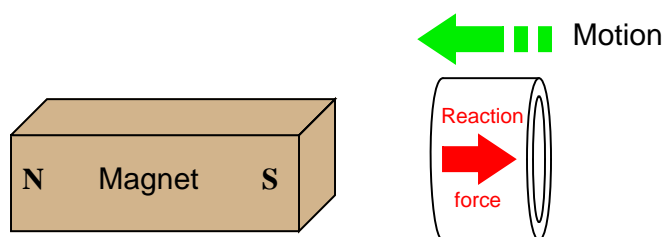

Also, describe what will happen if the copper ring is moved *away* from the end of the permanent magnet.  
[file 00254](#)

---

### Answer 34

The phenomenon is known as *Lenz's Law*. If the copper ring is moved *away* from the end of the permanent magnet, the direction of force will reverse and become attractive rather than repulsive.

Follow-up question: trace the direction of rotation for the induced electric current in the ring necessary to produce both the repulsive and the attractive force.

Challenge question: what would happen if the magnet's orientation were reversed (south pole on left and north pole on right)?

---

### Notes 34

This phenomenon is difficult to demonstrate without a very powerful magnet. However, if you have such apparatus available in your lab area, it would make a great piece for demonstration!

One practical way I've demonstrated Lenz's Law is to obtain a rare-earth magnet (*very* powerful!), set it pole-up on a table, then drop an aluminum coin (such as a Japanese Yen) so it lands on top of the magnet. If the magnet is strong enough and the coin is light enough, the coin will gently come to rest on the magnet rather than hit hard and bounce off.

A more dramatic illustration of Lenz's Law is to take the same coin and spin it (on edge) on a table surface. Then, bring the magnet close to the edge of the spinning coin, and watch the coin promptly come to a halt, without contact between the coin and magnet.

Another illustration is to set the aluminum coin on a smooth table surface, then quickly move the magnet over the coin, parallel to the table surface. If the magnet is close enough, the coin will be "dragged" a short distance as the magnet passes over.

In all these demonstrations, it is significant to show to your students that the coin itself is not magnetic. It will not stick to the magnet as an iron or steel coin would, thus any force generated between the coin and magnet is strictly due to *induced currents* and not ferromagnetism.



Question 35

Lenz's Law describes the opposition to changes in magnetic flux resulting from electromagnetic induction between a magnetic field and an electrical conductor. One apparatus capable of demonstrating Lenz's Law is a copper or aluminum disk (electrically conductive, but non-magnetic) positioned close to the end of a powerful permanent magnet. There is no attraction or repulsion between the disk and magnet when there is no motion, but a force will develop between the two objects if either is suddenly moved. This force will be in such a direction that it tries to resist the motion (i.e. the force tries to maintain the gap constant between the two objects):

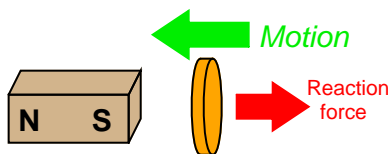

We know this force is magnetic in nature. That is, the induced current causes the disk itself to *become* a magnet in order to react against the permanent magnet's field and produce the opposing force. For each of the following scenarios, label the disk's induced magnetic poles (North and South) as it reacts to the motion imposed by an outside force:

Figure 1

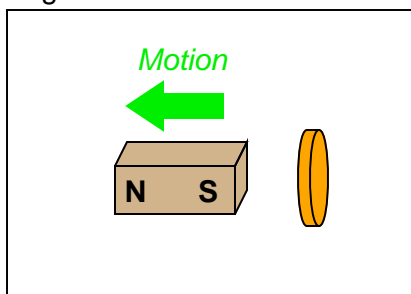

Figure 2

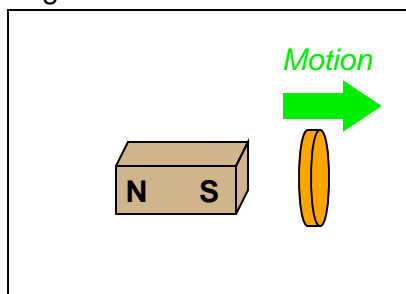

Figure 3

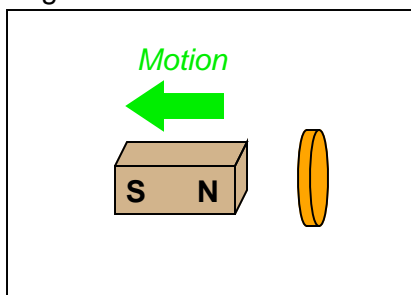
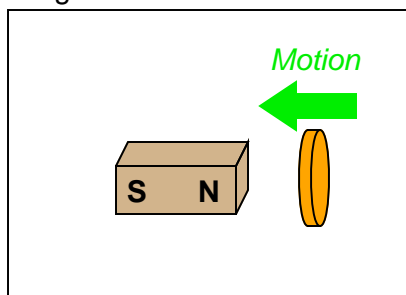
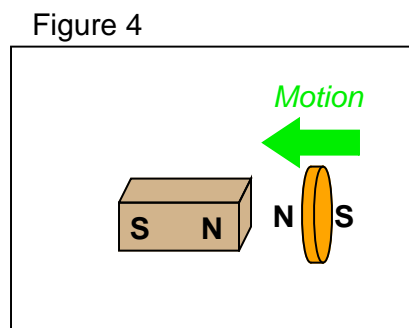
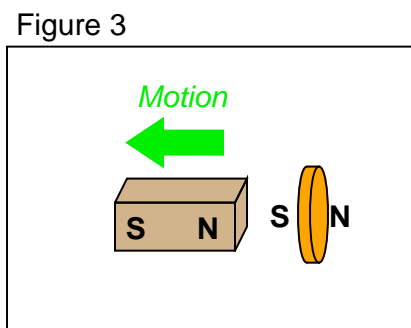
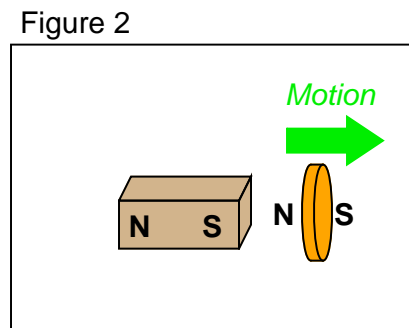
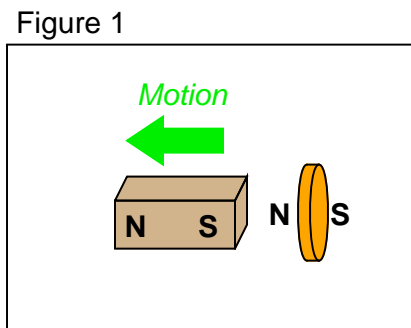

Figure 4



file 01982

The disk's own magnetic field will develop in such a way that it "fights" to keep a constant distance from the magnet:



Follow-up question: trace the direction of rotation for the induced electric current in the disk necessary to produce both the repulsive and the attractive force.

Notes 35

This phenomenon is difficult to demonstrate without a very powerful magnet. However, if you have such apparatus available in your lab area, it would make a great piece for demonstration!

One practical way I've demonstrated Lenz's Law is to obtain a rare-earth magnet (*very* powerful!), set it pole-up on a table, then drop an aluminum coin (such as a Japanese Yen) so it lands on top of the magnet. If the magnet is strong enough and the coin is light enough, the coin will gently come to rest on the magnet rather than hit hard and bounce off.

A more dramatic illustration of Lenz's Law is to take the same coin and spin it (on edge) on a table surface. Then, bring the magnet close to the edge of the spinning coin, and watch the coin promptly come to a halt, without contact between the coin and magnet.

Another illustration is to set the aluminum coin on a smooth table surface, then quickly move the magnet over the coin, parallel to the table surface. If the magnet is close enough, the coin will be "dragged" a short distance as the magnet passes over.

In all these demonstrations, it is significant to show to your students that the coin itself is not magnetic. It will not stick to the magnet as an iron or steel coin would, thus any force generated between the coin and magnet is strictly due to *induced currents* and not ferromagnetism.

Question 36

Combining Lenz's Law with the right-hand rule (or left-hand rule, if you follow electron flow instead of conventional flow) provides a simple and effective means for determining the direction of induced current in an induction coil. In the following examples, trace the direction of current through the load resistor:

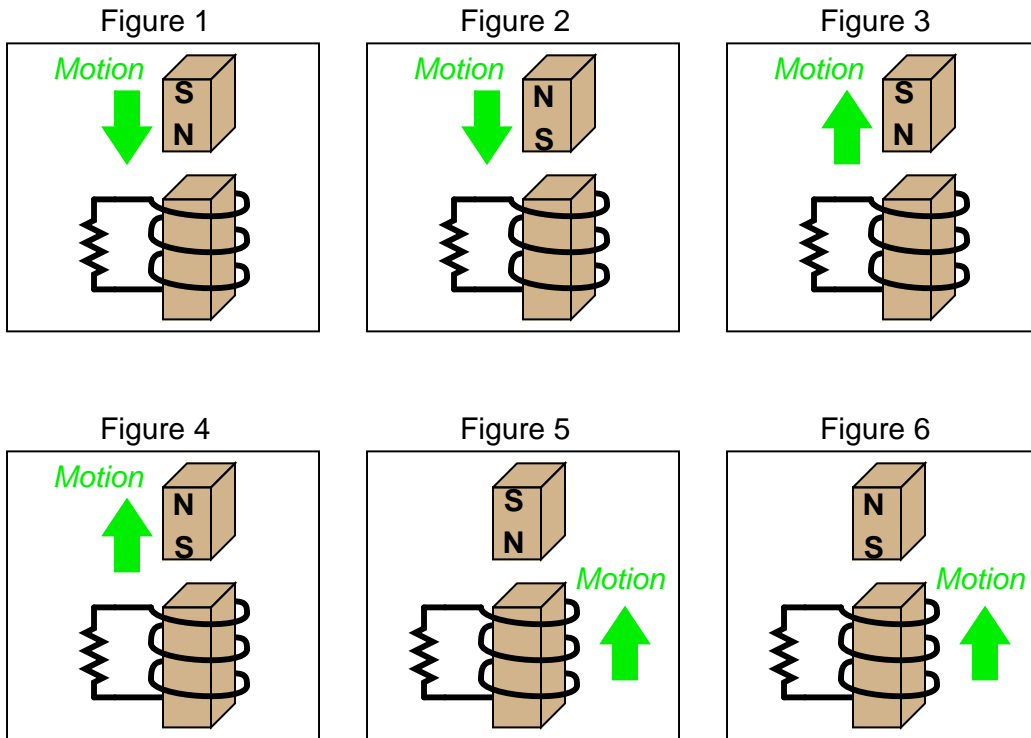

[file 01787](#)

Note: in case it isn't clear from the illustrations, Figures 1 through 4 show the magnet moving in relation to a stationary coil. Figures 5 and 6 show a coil moving in relation to a stationary magnet.

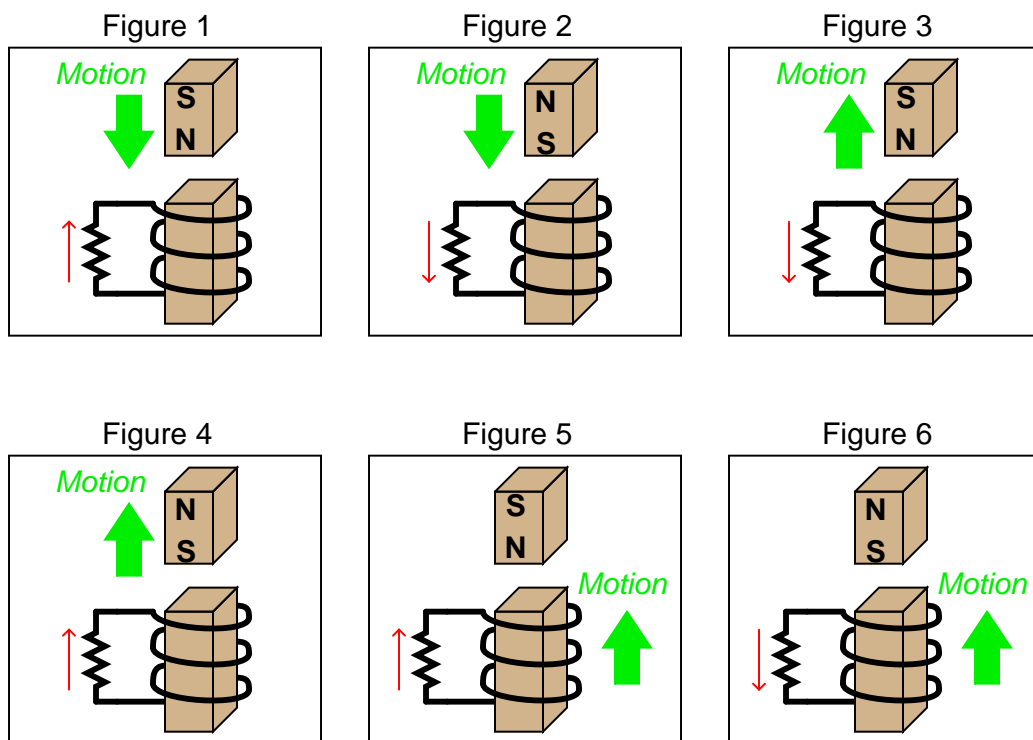

Note: all current directions shown using conventional flow notation (following the right-hand rule)

An easy way I find to remember Lenz's Law is to interpret it as *opposition to change*. The coil will try to become a magnet that fights the motion. A good way to get students thinking along these lines is to ask them, "What magnetic polarity would the coil have to assume (in each case) to resist the magnet's relative motion?" In other words, if the magnet moves closer to the coil, the coil will "magnetize" so as to push against the magnet. If the magnet moves away from the coil, the coil will "magnetize" so as to attract the magnet.

Question 37

Determine the polarity of the coil's induced voltage for each of the following examples. Be careful to note the direction each coil is wrapped around its core – the coils are not all identical!

Figure 1

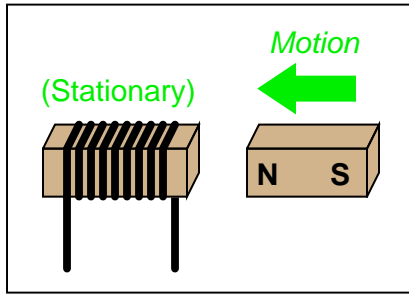

Figure 2

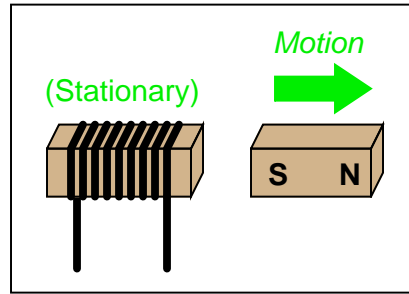

Figure 3

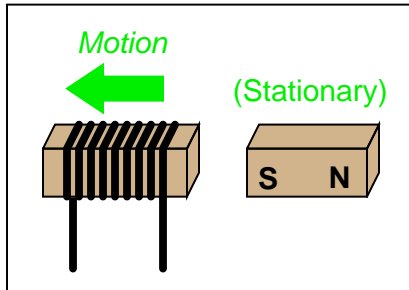
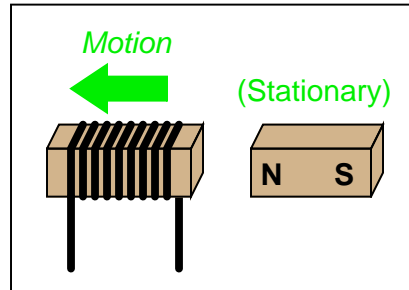

Figure 4



file 01788

Figure 1

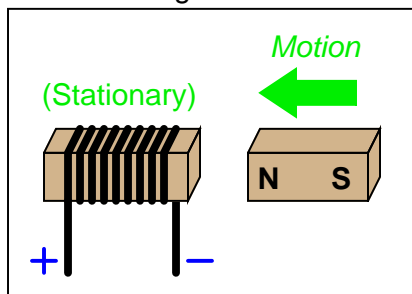

Figure 2

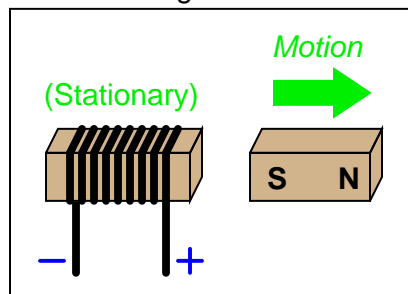

Figure 3

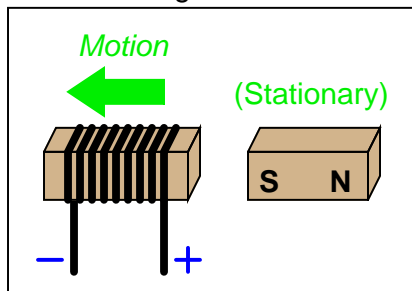
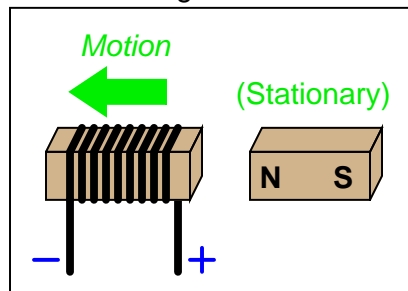

Figure 4



Notes 37

It might help students to visualize the polarity if they imagine a resistive load connected between the two output terminals, and then figured out which direction induced *current* would go through that load. Once that determination is made, voltage polarity (considering the coil as an energy source) should be easier to visualize. A mistake many beginning students make when doing this, though, is to fail to recognize the coil as the *source* of electrical energy and the resistor as the *load*, so be prepared to address this misunderstanding.

If this does not help, suggest they first identify the magnetic polarity of the coil's induced field: determine which end of the coil is "trying" to be North and which is "trying" to be South. Of course, no induced field will form unless the coil has a complete circuit to sustain the induced current, but it is still helpful to imagine a load resistor or even a short completing the circuit so that induced current and thus induced magnetic polarity may be visualized.

---

### Question 38

Electromechanical watt-hour meters use an aluminum disk that is spun by an electric motor. To generate a constant "drag" on the disk necessary to limit its rotational speed, a strong magnet is placed in such a way that its lines of magnetic flux pass perpendicularly through the disk's thickness:

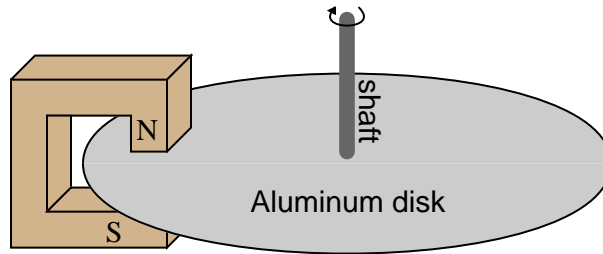

Explain the phenomenon behind this magnetic "drag" mechanism, and also explain how the permanent magnet assembly should be re-positioned so that it provides *less* drag on the disk for the same rotational speed.

[file 00259](#)

---

### Answer 38

This is an example of *Lenz' Law*. For decreased drag on the disk, the magnet needs to be moved over a spot on the disk that has less surface velocity (I'll let you figure out where that might be).

Follow-up question: suppose you *move* a strong magnet past the surface of an aluminum disk. What will happen to the disk, if anything?

---

### Notes 38

An important calibration adjustment on electromechanical wattmeter assemblies is the positioning of the "drag" magnet, making this question a very practical one. An interesting challenge for students is to ask them to sketch the flow of induced electric current in the disk as it rotates past the magnet!

The follow-up question is actually a preview of induction motor theory, and may be illustrated with a powerful (rare-earth) magnet and a metal coin (Japanese Yen, made of aluminum, work very well for this, being good electrical conductors and lightweight!).

---

### Question 39

One context in which to understand Lenz's Law is the well-known physical law called the Conservation of Energy, which states that energy can neither be created (from nothing) nor destroyed (to nothing). This well-founded law of physics is the general principle forbidding so-called "over-unity" or "free energy" machines, where energy would supposedly be produced from no source whatsoever.

Demonstrate that if Lenz's Law were reversed, the Conservation of Energy principle would be violated. In other words, imagine what would happen if the effects of Lenz's Law were exactly opposite in direction, and show how this would result in more energy produced by a system than what is input to that system.

[file 01789](#)

---

### Answer 39

There are several ways to demonstrate this. Perhaps the easiest to visualize (from an energy perspective) is a rotary magnetic "drag" disk, where the perpendicular intersection of a magnetic field and an electrically conductive disk creates a resistive drag (opposing) torque when the disk is rotated. The effects of reversing the Lenz force direction should be obvious here.

---

### Notes 39

This question may very well lead to a fruitful discussion on perpetual motion and claims of "free energy" machines, the very existence of such claims in modern times being outstanding evidence of scientific illiteracy. Not only do a substantial number of people seem ignorant of the Conservation of Energy principle and just how well it is founded, but also seem unable to grasp the importance of the ultimate test for such a device: to be able to power itself (and a load) indefinitely. But I digress . . .



---

Question 40

Based on your knowledge of Lenz's Law, explain how one could construct an *electromagnetic brake*, whereby the energization of an electromagnet coil would produce mechanical "drag" on a rotating shaft without the need for contact between the shaft and a brake pad.

[file 01786](#)

---

Answer 40

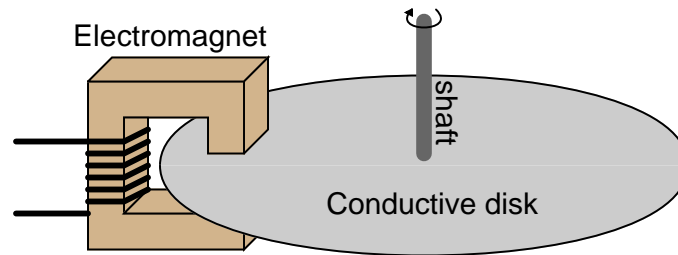

Follow-up question: describe some of the advantages and disadvantages that a magnetic brake would have, compared to mechanical brakes (where physical contact produces friction on the shaft).

Challenge question: normal (mechanical) brakes become hot during operation, due to the friction they employ to produce drag. Will an electromechanical brake produce heat as well, given that there is no physical contact to create friction?

---

Notes 40

Electromagnetic brakes are very useful devices in industry. One interesting application I've seen for this technology is the mechanical load for an automotive dynamometer, where a car is driven onto a set of steel rollers, with one roller coupled to a large metal disk (with electromagnets on either side). By varying the amount of current sent to the electromagnets, the degree of mechanical drag may be varied.

Incidentally, this disk becomes very hot when in use, because the automobile's power output cannot simply vanish – it must be converted into a different form of energy in the braking mechanism, and heat it is.

---

Question 41

Ideal *voltage sources* and ideal *current sources*, while both being sources of electrical power, behave very differently from one another:

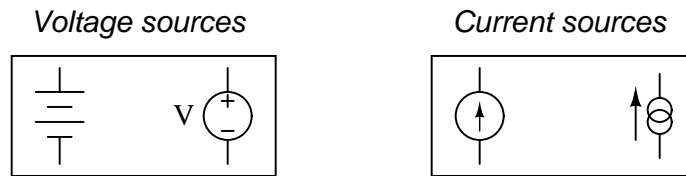

Explain how each type of electrical source would behave if connected to a variable-resistance load. As this variable resistance were increased and decreased, how would each type of source respond?

[file 03226](#)

---

Answer 41

An ideal voltage source will output as much or as little current as necessary to maintain a constant voltage across its output terminals, for any given load resistance. An ideal current source will output as much or as little voltage as necessary to maintain a constant current through it, for any given load resistance.

---

Notes 41

Ask your students to think of a few "thought experiment" scenarios where voltage and current sources could be put to test. Have them invent voltage and current values for these voltage and current sources, respectively, then calculate all other circuit parameters given several different values of load resistance.

Question 42

A *voltage source* is a source of electricity that (ideally) outputs a constant voltage. That is, a perfect voltage source will hold its output voltage constant regardless of the load imposed upon it:

*Ideal voltage sources assumed*

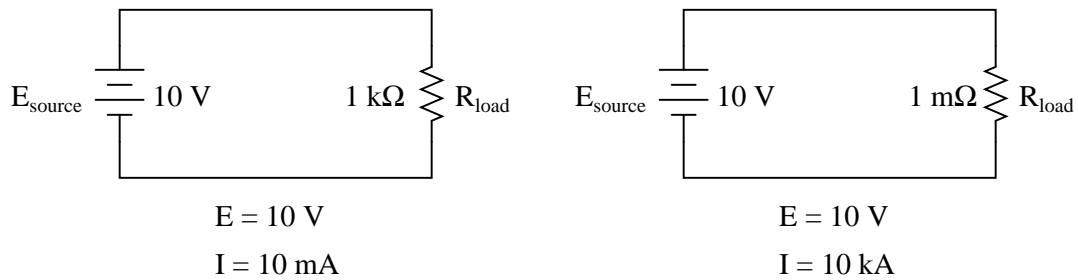

In real life, there is no such thing as a perfect voltage source, but sources having extremely low internal resistance come close.

Another type of electricity source is the *current source*, which (ideally) outputs a constant current regardless of the load imposed upon it. A common symbol for a current source is a circle with an arrow inside (always pointing in the direction of conventional flow, not electron flow!). Another symbol is two intersecting circles, with an arrow nearby pointing in the direction of conventional flow:

*Current sources*



Predict how an ideal current source would behave for the following two load scenarios:

*Ideal current sources assumed*

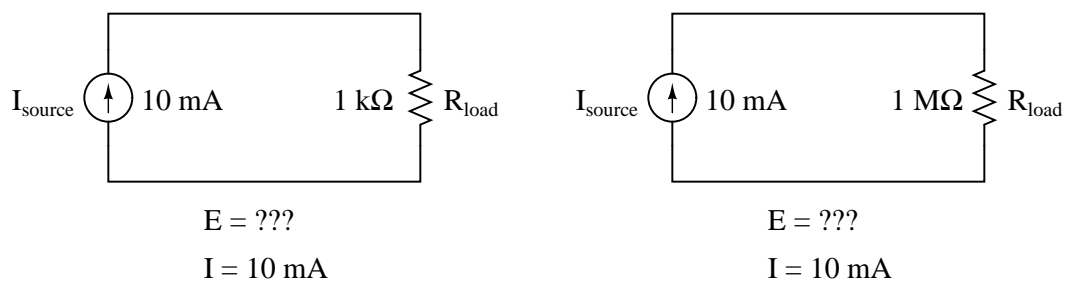

file 01735

*Ideal current sources assumed*

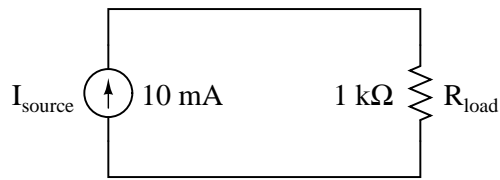

$E = 10 \text{ V}$   
 $I = 10 \text{ mA}$

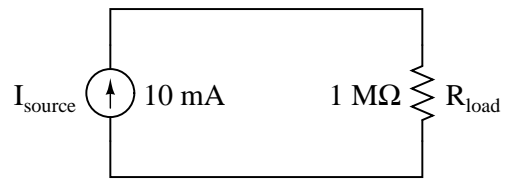

$E = 10 \text{ kV}$   
 $I = 10 \text{ mA}$

Follow-up question: identify the polarity of the voltage drops across the resistors in the circuits shown above.

---

Notes 42

Let students know that there really is such a thing as a perfect current source, just as there is no such thing as a perfect voltage source. However, there are devices that closely approximate ideal current sources (current transformers in AC circuits and "current mirror" DC transistor circuits, for example).

Question 43

A very common sort of graph used in electronics work is the *load line*, showing all possibilities of load voltage and load current that a particular power source is able to supply to a load:

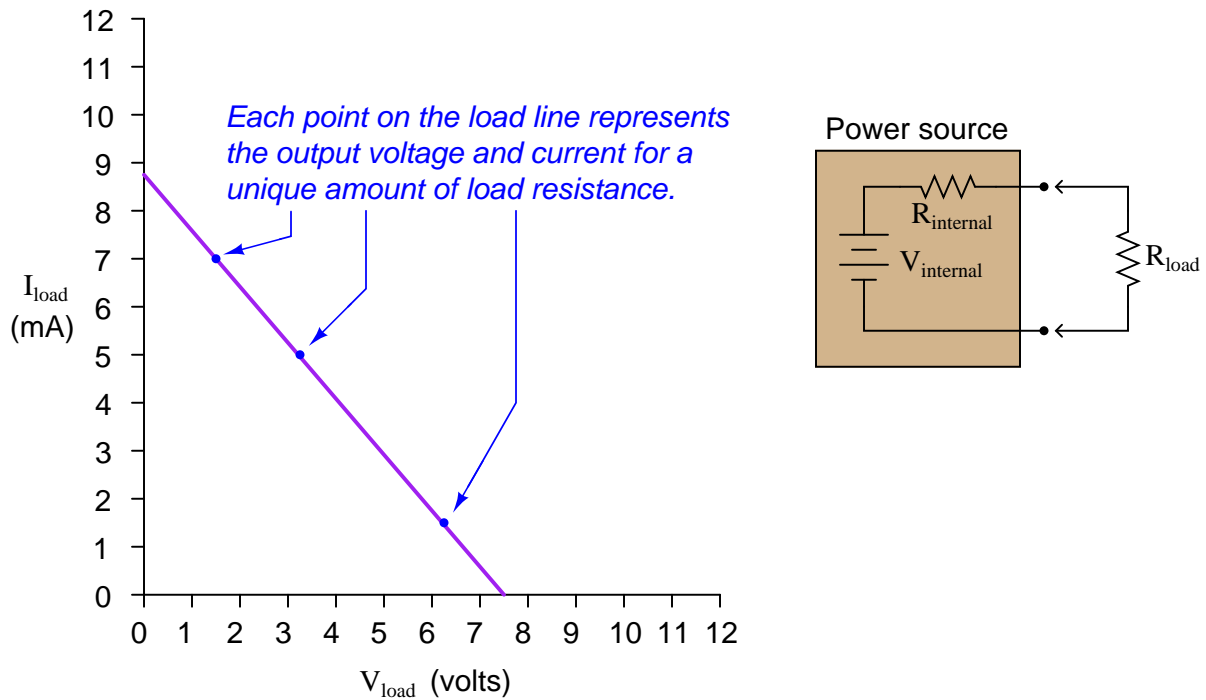

Note how the load line shows the voltage "sag" of the power source in relation to the amount of current drawn by the load. At high currents, the output voltage will be very low (upper-left end of load line). At low currents, the output voltage will be near its maximum (lower-right end of load line). If all internal components of the power source are *linear* in nature, the load line will always be perfectly straight.

Plot the load line for a power source having an internal voltage ( $V_{internal}$ ) of 11 volts and an internal resistance ( $R_{internal}$ ) of 1.2 k $\Omega$ . Superimpose your load line onto the load line graph shown above. Hint: it only takes two points to define a line!

[file 03513](#)

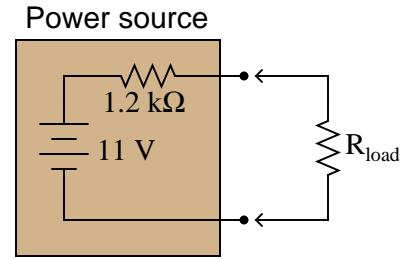
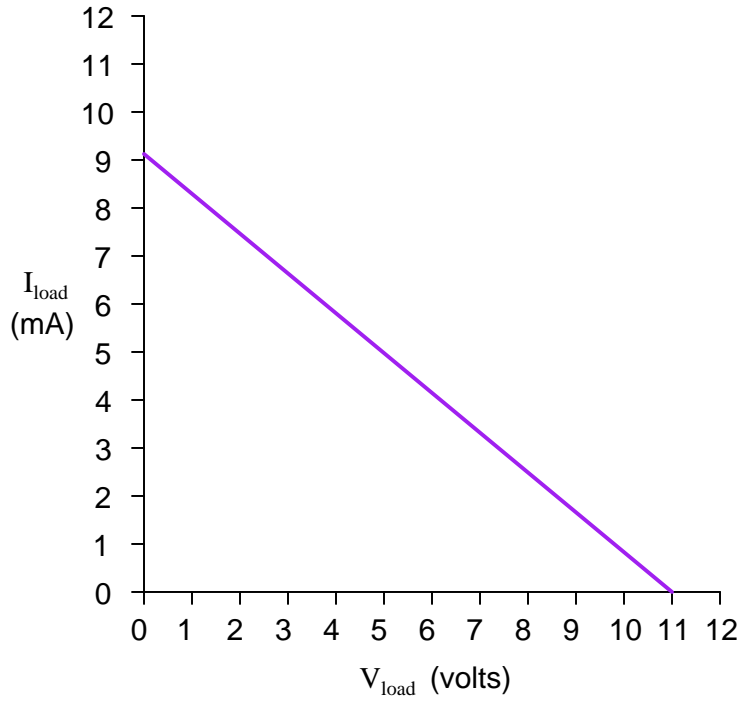

Hint: the easiest points to find on this load line are the points representing open-circuit and short-circuit conditions (i.e.  $R_{load} = \infty \Omega$  and  $R_{load} = 0 \Omega$ , respectively).

Follow-up questions: what will happen to the load line if we change the internal resistance of the power source circuit? What will happen to the load line if we change the internal voltage value of the power source circuit?

Notes 43

The purpose of this question is to lend an analytical geometric perspective to the subject of power source behavior, by showing how the output voltage and current may be plotted on a graph. The condition of circuit linearity is important, as it permits us to confidently plot the load line by finding only two points on it.

---

Question 44

Calculate the voltage dropped across the load resistor, and the current through the load resistor, for the following load resistance values in this circuit:

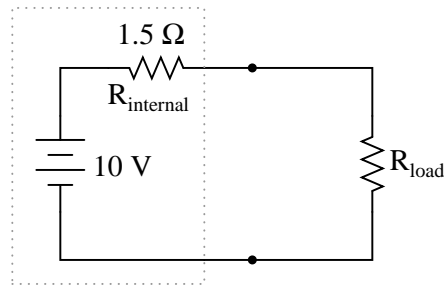

$R_{load}$	$E_{load}$	$I_{load}$
1 kΩ		
2 kΩ		
5 kΩ		
8 kΩ		
10 kΩ		

Do the "boxed" components in this circuit behave more like a constant voltage source, or a constant current source? Explain your answer.

[file 00389](#)

---

Answer 44

I'll let you do the calculations on your own! Hint: there is a way to figure out the answer without having to calculate all five load resistance scenarios.

Follow-up question: would you say that voltage sources are typically characterized as having high internal resistances or low internal resistances? What about current sources? Explain your answers.

---

Notes 44

Ask your students to make a general prediction about the internal resistance of voltage sources. Based on our calculations in this circuit, would you expect voltage sources to have high internal resistance or low internal resistance? Also ask what constitutes a "high" or a "low" internal resistance for a power source. Is this a relative determination, or an absolute determination?

---

Question 45

Calculate the voltage dropped across the load resistor, and the current through the load resistor, for the following load resistance values in this circuit:

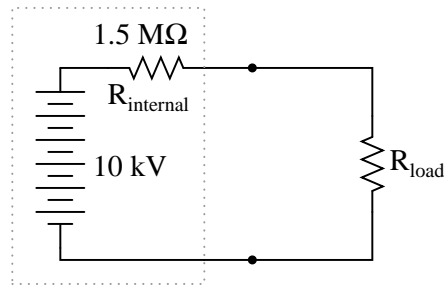

$R_{load}$	$E_{load}$	$I_{load}$
1 kΩ		
2 kΩ		
5 kΩ		
8 kΩ		
10 kΩ		

Do the "boxed" components in this circuit behave more like a constant voltage source, or a constant current source? Explain your answer.

[file 00390](#)

---

Answer 45

I'll let you do the calculations on your own! Hint: there is a way to figure out the answer without having to calculate all five load resistance scenarios.

Follow-up question #1: would you say that voltage sources are typically characterized as having high internal resistances or low internal resistances? What about current sources? Explain your answers.

Follow-up question #2: although it is difficult to find real devices that approximate ideal current sources, there are a few that do. An AC device called a "current transformer" is one of them. Describe which scenario would be the safest from a perspective of shock hazard: an open-circuited current transformer, or a short-circuited current transformer. Why is this?

---

Notes 45

Ask your students to make a general prediction about the internal resistance of current sources. Based on our calculations in this circuit, would you expect voltage sources to have high internal resistance or low internal resistance? Also ask what constitutes a "high" or a "low" internal resistance for a power source. Is this a relative determination, or an absolute determination?



---

Question 46

In the following circuit, an adjustable voltage source is connected in series with a resistive load and another voltage source:

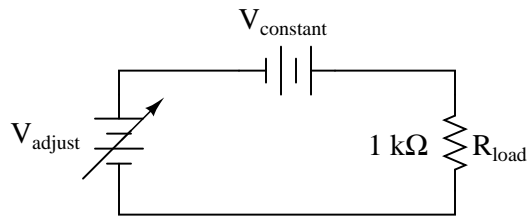

Determine what will happen to the current in this circuit if the adjustable voltage source is increased.

In this next circuit, an adjustable voltage source is connected in series with a resistive load and a *current* source:

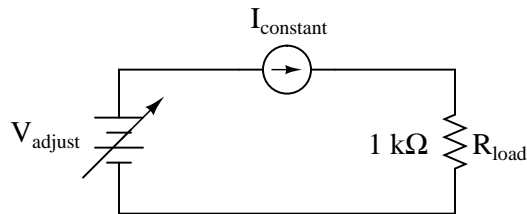

Now determine what will happen to the current in this second circuit if the adjustable voltage source is increased.

One way to define electrical resistance is by comparing the *change* in applied voltage ( $\Delta V$ ) to the *change* in resultant current ( $\Delta I$ ). This is mathematically expressed by the following ratio:

$$R = \frac{\Delta V}{\Delta I}$$

From the perspective of the adjustable voltage source ( $V_{\text{adjust}}$ ), and as defined by the above equation, which of these two circuits has the greatest resistance? What does this result suggest about the equivalent resistance of a constant-voltage source versus the equivalent resistance of a constant-current source?

[file 03224](#)

---

Answer 46

In the first circuit, current will increase as  $V_{adjust}$  is increased, yielding a finite total resistance. In the second circuit, current will remain constant as  $V_{adjust}$  is increased, yielding an infinite total resistance.

Follow-up question: calculate  $R$  as defined by the formula  $\frac{\Delta V}{\Delta I}$  for these two circuits, assuming  $V_{adjust}$  changes from 15 volts to 16 volts (1 volt  $\Delta V$ ):

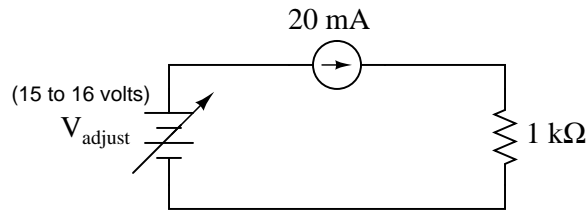
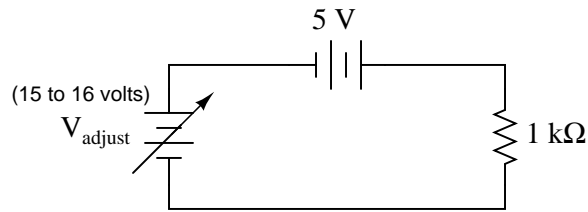

---

Notes 46

If students are unable to analyze the two circuits qualitatively as suggested in the question, the follow-up question should clear things up. The point of all this, of course, is for students to see that a constant voltage source has zero internal resistance and that a constant current source has infinite internal resistance.

In case anyone should ask, the proper definition for resistance is expressed as a derivative. That is, instead of  $R = \frac{\Delta V}{\Delta I}$  we should have  $R = \frac{dV}{dI}$ .

*Load lines* are special types of graphs used in electronics to characterize the output voltage and current behavior of different power sources:

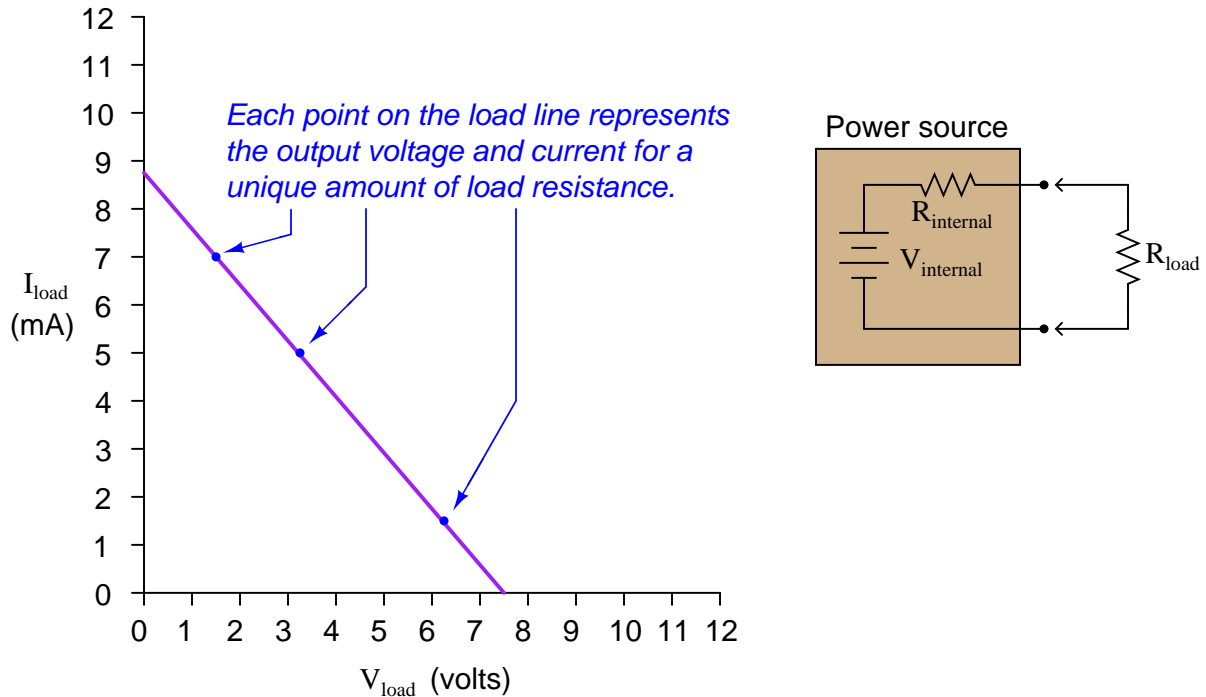

If we know that all the internal components of a power source are inherently *linear*, we know that the load line plot will indeed be a straight line. And, if we know the plot will be a straight line, all we need in order to plot a complete load line are *two* data points.

Usually, the easiest data points to gather for a circuit – whether it be a real circuit or an hypothetical circuit existing on paper only – is the *open-circuit* condition and the *short-circuit* condition. In other words, we see how much voltage the source will output with no load connected ( $I_{load} = 0$  milliamps) and then we see how much current the source will output into a direct short ( $V_{load} = 0$  volts):

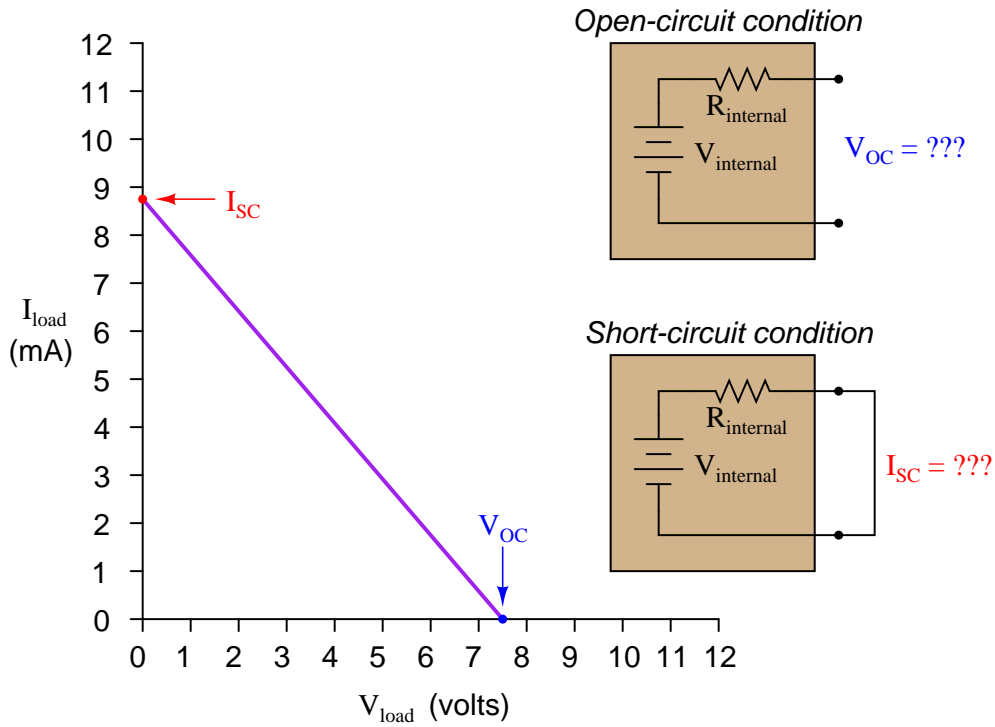

Suppose we have two differently-constructed power sources, yet both of these sources share the same open-circuit voltage ( $V_{OC}$ ) and the same short-circuit current ( $I_{SC}$ ). Assuming the internal components of both power sources are linear in nature, explain how we would know without doubt that the two power sources were electrically equivalent to one another. In other words, explain how we would know just from the limited data of  $V_{OC}$  and  $I_{SC}$  that these two power sources will behave exactly the same when connected to the same load resistance, whatever that load resistance may be.

*How do we know these two power sources are completely equivalent to one another just from their equal open-circuit voltage and short-circuit current figures?*

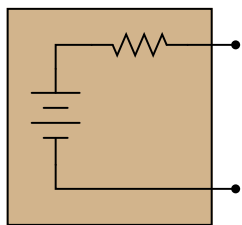

$V_{OC} = 7.5$  volts  
 $I_{SC} = 8.75$  mA

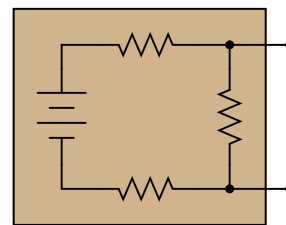

$V_{OC} = 7.5$  volts  
 $I_{SC} = 8.75$  mA

file 03514

---

Answer 47

With equal  $V_{OC}$  and  $I_{SC}$  figures and with linear componentry, the load lines must be identical. This means that *any* load resistance, when connected to each of the power sources, will experience the exact same voltage and current.

---

Notes 47

This is a "poor man's proof" of Thévenin's and Norton's theorems: that we may completely characterize a power source in a simple, equivalent circuit by finding the original circuit's open-circuit voltage and short-circuit current. The assumption of linearity allows us to define the load line for each power source from just these two data points.

---

Question 48

Suppose you were handed a black box with two metal terminals on one side, for attaching electrical (wire) connections. Inside this box, you were told, was a voltage source (an ideal voltage source connected in series with a resistance):

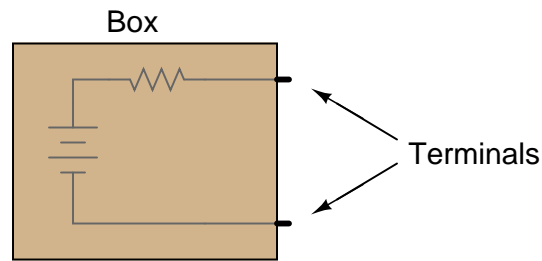

How would you experimentally determine the voltage of the ideal voltage source inside this box, and how would you experimentally determine the resistance of the series resistor? By "experimentally," I mean determine voltage and resistance using actual test equipment rather than assuming certain component values (remember, this "black box" is sealed, so you cannot look inside!).

[file 01037](#)

---

Answer 48

Measure the open-circuit voltage between the two terminals, and then measure the short-circuit current. The voltage source's value is measured, while the resistor's value is calculated using Ohm's Law.

---

Notes 48

Ask your students how they would apply this technique to an abstract circuit problem, to reduce a complex network of sources and resistances to a single voltage source and single series resistance (Thévenin equivalent).

---

Question 49

Electrochemical batteries are supposed to act as constant voltage sources, outputting an unchanging voltage for a wide range of load currents. The output voltage of real batteries, though, always "sags" to some degree under the influence of a load.

Explain why this is so, in terms of modeling the battery as an ideal voltage source combined with a resistance. How do you suggest the internal resistance of a chemical battery be experimentally measured?

[file 03223](#)

---

Answer 49

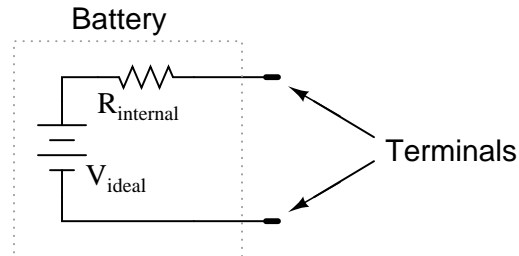

I'll let you figure out how to measure this internal resistance!

---

Notes 49

Although real chemical batteries do not respond as simply as this equivalent circuit would suggest, the model is accurate enough for many purposes.

---

Question 50

Suppose you were handed a black box with two metal terminals on one side, for attaching electrical (wire) connections. Inside this box, you were told, was a current source (an ideal current source connected in parallel with a resistance):

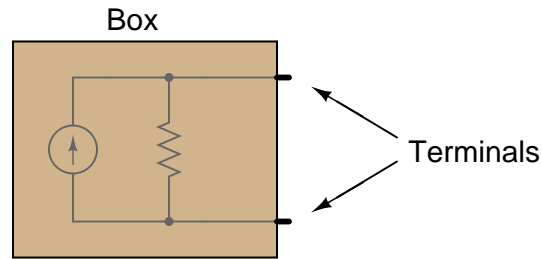

How would you experimentally determine the current of the ideal current source inside this box, and how would you experimentally determine the resistance of the parallel resistor? By "experimentally," I mean determine current and resistance using actual test equipment rather than assuming certain component values (remember, this "black box" is sealed, so you cannot look inside!).

[file 01038](#)

---

Answer 50

Measure the open-circuit voltage between the two terminals, and then measure the short-circuit current. The current source's value is measured, while the resistor's value is calculated using Ohm's Law.

---

Notes 50

Ask your students how they would apply this technique to an abstract circuit problem, to reduce a complex network of sources and resistances to a single current source and single parallel resistance (Norton equivalent).



---

Question 51

Suppose you were handed a black box with two metal terminals on one side, for attaching electrical (wire) connections. Inside this box, you were told, was a voltage source connected in series with a resistance.

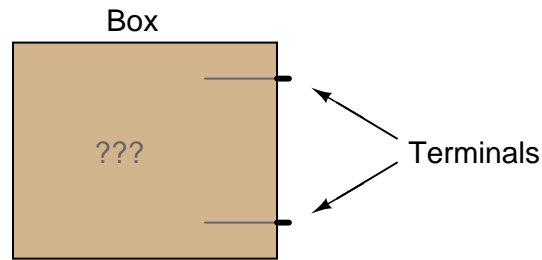

Your task was to experimentally determine the values of the voltage source and the resistor inside the box, and you did just that. From your experimental data you then sketched a circuit with the following component values:

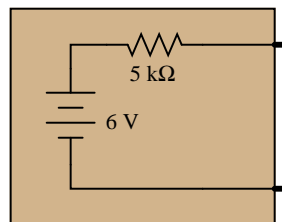

However, you later discovered that you had been tricked. Instead of containing a single voltage source and a single resistance, the circuit inside the box actually looked like this:

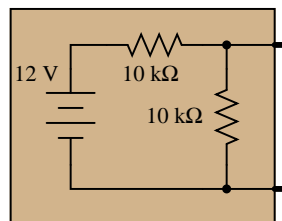

Demonstrate that these two different circuits are indistinguishable from the perspective of the two metal terminals, and explain what general principle this equivalence represents.

[file 02020](#)

---

Answer 51

A good way to demonstrate the electrical equivalence of these circuits is to calculate their responses to identical load resistor values. The equivalence you see here is an application of *Thévenin's Theorem*.

---

Notes 51

Ask your students to clearly state Thévenin's Theorem, and explain how it may be applied to the two-resistor circuit to obtain the one-resistor circuit.

---

Question 52

Suppose you were handed a black box with two metal terminals on one side, for attaching electrical (wire) connections. Inside this box, you were told, was a voltage source connected in series with a resistance.

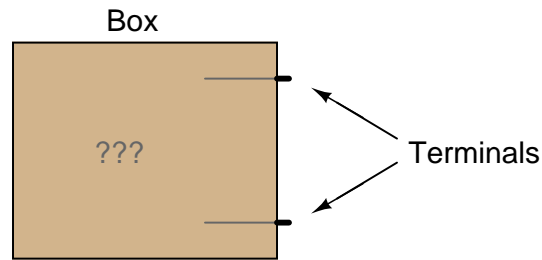

Your task was to experimentally determine the values of the voltage source and the resistor inside the box, and you did just that. From your experimental data you then sketched a circuit with the following component values:

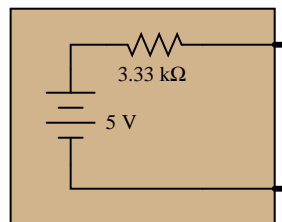

However, you later discovered that you had been tricked. Instead of containing a single voltage source and a single resistance, the circuit inside the box actually looked like this:

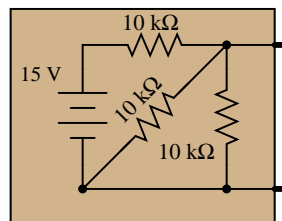

Demonstrate that these two different circuits are indistinguishable from the perspective of the two metal terminals, and explain what general principle this equivalence represents.

[file 03227](#)

---

Answer 52

A good way to demonstrate the electrical equivalence of these circuits is to calculate their responses to identical load resistor values. The equivalence you see here is an application of *Thévenin's Theorem*.

---

Notes 52

Ask your students to clearly state Thévenin's Theorem, and explain how it may be applied to the two-resistor circuit to obtain the one-resistor circuit.

Question 53

Examine this circuit, consisting of an ideal voltage source and several resistors:

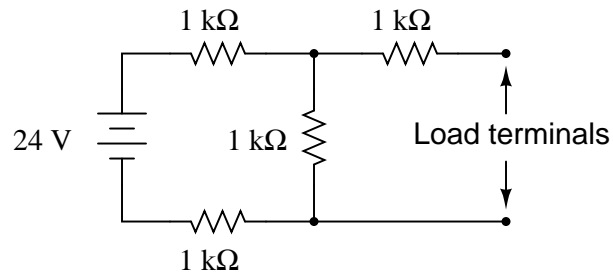

First, calculate the voltage seen at the load terminals with a voltmeter directly connected across them (an *open-circuit* condition):

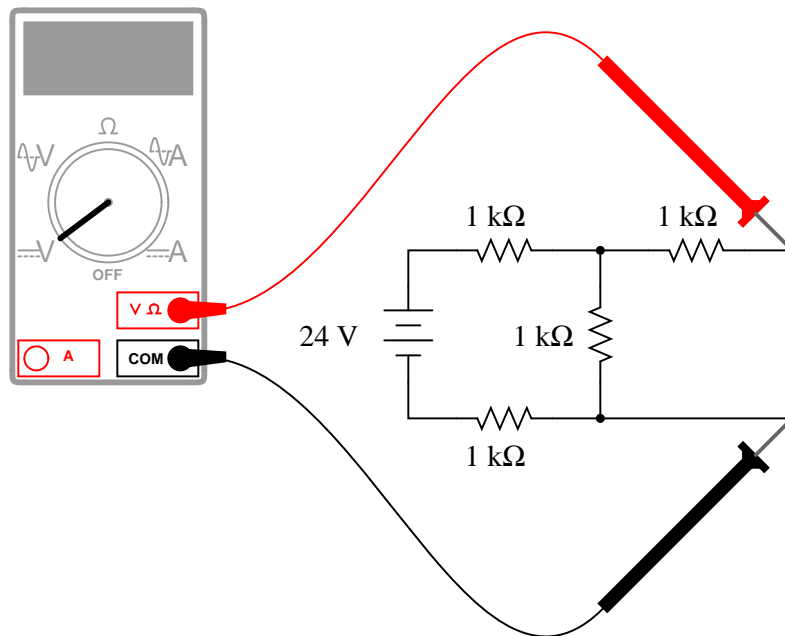

Next, calculate the current seen at the load terminals with an ammeter directly connected across them (a *short-circuit* condition):

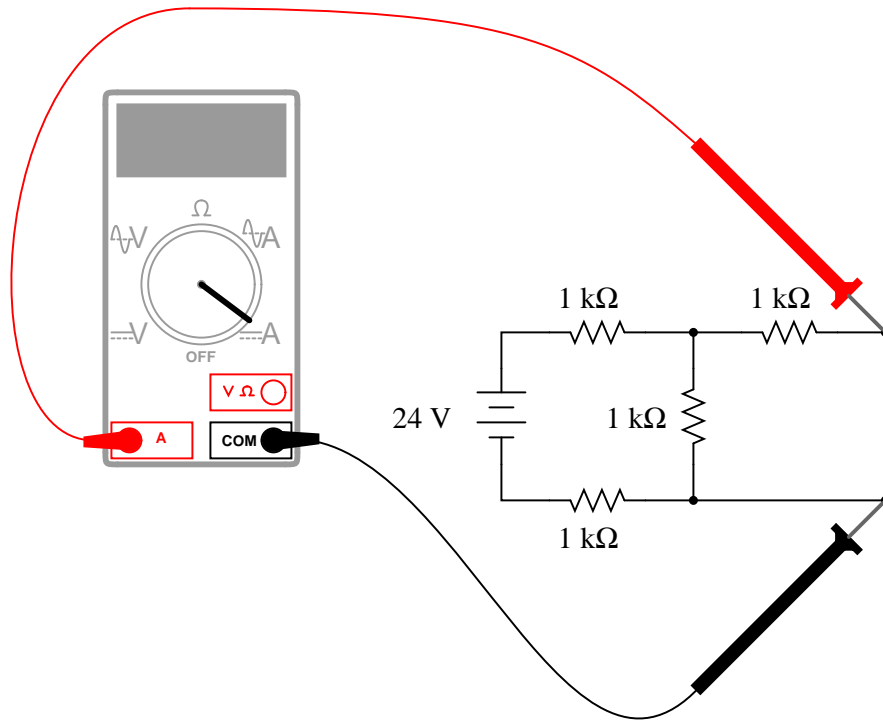

Based on these open- and short-circuit calculations, draw a new circuit consisting of a single voltage source and a single (series) resistor that will respond in the exact same manner. In other words, design an *equivalent circuit* for the circuit shown here, using the minimum number of possible components.

[file 03228](#)

Answer 53

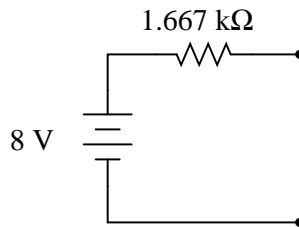

Follow-up question: is this circuit truly equivalent to the original shown in the question? Sure, it responds the same under extreme conditions (open-circuit and short-circuit), but will it respond the same as the original circuit under modest load conditions (say, with a 5 kΩ resistor connected across the load terminals)?

Notes 53

The purpose of this question is to get students thinking about Thévenin equivalent circuits from the perspective of how the original circuit responds to extreme variations in load resistance.

This question is also a good review of voltmeter and ammeter behavior: that ideal voltmeters act as open circuits (infinite input resistance) while ideal ammeters act as short circuits (zero input impedance).

---

Question 54

Suppose you were handed a black box with two metal terminals on one side, for attaching electrical (wire) connections. Inside this box, you were told, was a current source connected in parallel with a resistance.

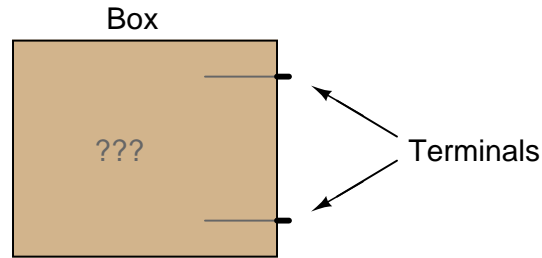

Your task was to experimentally determine the values of the current source and the resistor inside the box, and you did just that. From your experimental data you then sketched a circuit with the following component values:

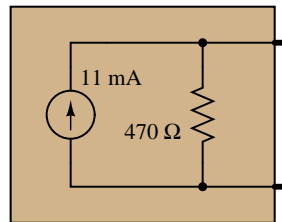

However, you later discovered that you had been tricked. Instead of containing a current source and a resistor, the circuit inside the box was actually a *voltage source* connected in *series* with a resistor:

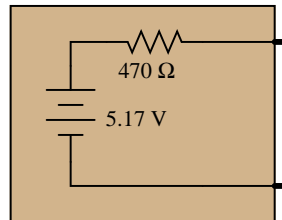

Demonstrate that these two different circuits are indistinguishable from the perspective of the two metal terminals, and explain what general principle this equivalence represents.

[file 02024](#)

---

Answer 54

A good way to demonstrate the electrical equivalence of these circuits is to calculate their responses to identical load resistor values. The equivalence you see here proves that Thévenin and Norton equivalent circuits are interchangeable.

Follow-up question: give a step-by-step procedure for converting a Thévenin equivalent circuit into a Norton equivalent circuit, and visa-versa.

---

Notes 54

Ask your students to clearly state both Thévenin's and Norton's Theorems, and also discuss why both these theorems are important electrical analysis tools.

---

Question 55

Is it possible to regard this complex network of power sources and resistances as a simple voltage source (one ideal voltage source in series with an internal resistance), or as a simple current source (one ideal current source in parallel with an internal resistance)? Why or why not?

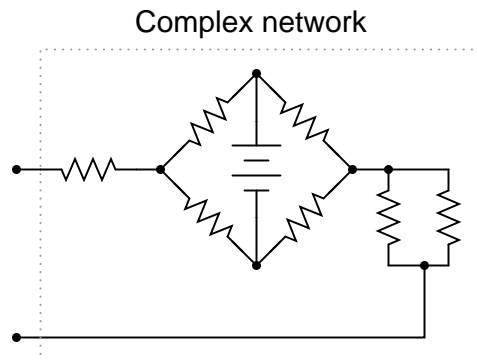

file 01036

---

Answer 55

Yes, because all the constituent components are *linear* and *bilateral*.

Follow-up question: why would anyone want to represent this complex network as either a simple voltage source or a simple current source?

---

Notes 55

Ask your students what it means for an electrical or electronic component to be considered "linear," and also what it means to be considered "bilateral." Can they give examples of components that are nonlinear, and/or unilateral?

---

Question 56

Give a step-by-step procedure for reducing this circuit to a Thévenin equivalent circuit (one voltage source in series with one resistor):

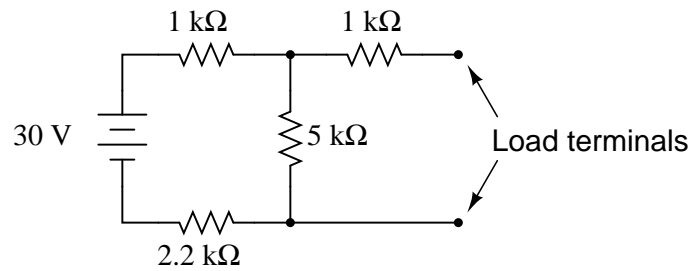

file 02021

---

Answer 56

I will let you research the procedure for determining Thévenin equivalent circuits, and explain it in your own words. Here is the equivalent circuit for the circuit given in the question:

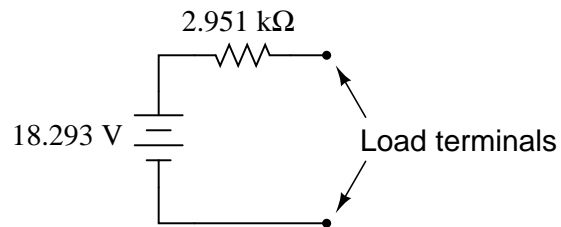

---

Notes 56

It should be easy for your students to research an algorithm (step-by-step procedure) for determining a Thévenin equivalent circuit. Let them do the work, and explain it to you and their classmates!

---

Question 57

Give a step-by-step procedure for reducing this circuit to a Norton equivalent circuit (one current source in parallel with one resistor):

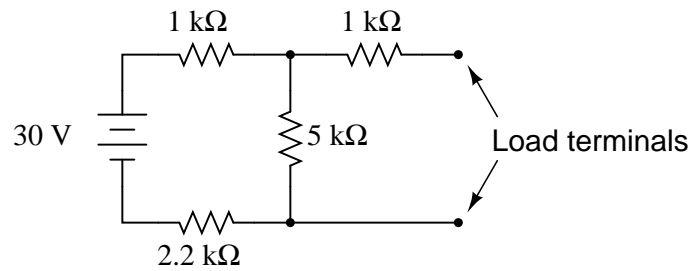

file 03230

---

Answer 57

I will let you research the procedure for determining Norton equivalent circuits, and explain it in your own words. Here is the equivalent circuit for the circuit given in the question:

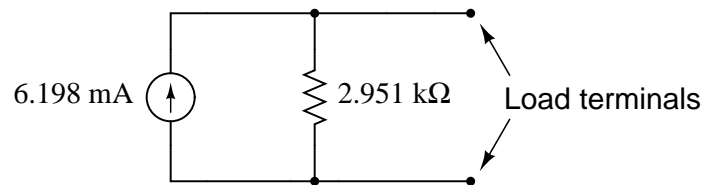

---

Notes 57

It should be easy for your students to research an algorithm (step-by-step procedure) for determining a Norton equivalent circuit. Let them do the work, and explain it to you and their classmates!



---

Question 58

Use Thévenin's Theorem to determine a simple equivalent circuit for the 10 volt source, the 5 kΩ resistor, and the 2.2 kΩ resistor; then calculate the voltage across the 1 kΩ load:

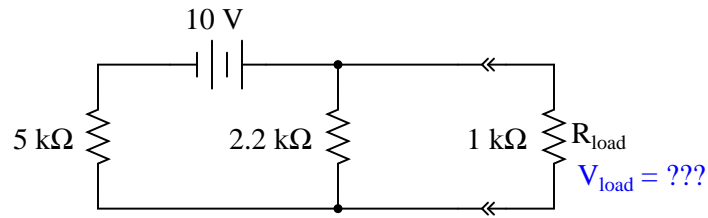

This exercise may seem pointless, as it is easy enough to obtain the answer simply by series-parallel analysis of this circuit. However, there is definite value in determining a Thévenin equivalent circuit for the voltage source, 5 kΩ resistor, and 2.2 kΩ resistor if the load voltage for *several different* values of load resistance needs to be predicted. Explain why Thévenin's Theorem becomes the more efficient way to predict load voltage if multiple load resistor values are considered.

[file 03241](#)

---

Answer 58

$$V_{load} = 1.209 \text{ volts}$$

---

Notes 58

Ask your students to show how (step-by-step) they arrived at the equivalent circuit, prior to calculating load voltage.

In case students are unfamiliar with the "double-chevron" symbols in the schematic diagram, let them know that these represent male/female connector pairs.

---

Question 59

Use Thévenin's Theorem to determine a simple equivalent circuit for the 3 mA source, the 8 kΩ resistor, and the 3.3 kΩ resistor; then calculate the voltage across the 1 kΩ load:

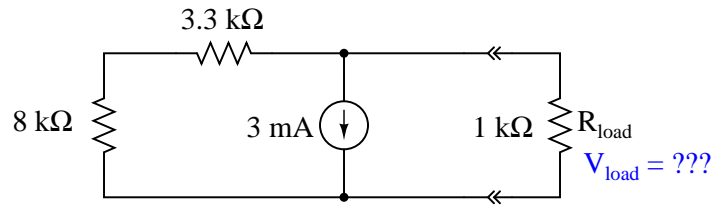

file 03242

---

Answer 59

$$V_{load} = 2.756 \text{ volts}$$

Follow-up question: although analyzing this circuit by series-parallel analysis is probably easier than using Thévenin's Theorem, there is definite value to doing it the way this question instructs when considering many different load resistance possibilities. Explain why this is.

---

Notes 59

Ask your students to show how (step-by-step) they arrived at the equivalent circuit, prior to calculating load voltage.

In case students are unfamiliar with the "double-chevron" symbols in the schematic diagram, let them know that these represent male/female connector pairs.

---

Question 60

Suppose a 12 volt lead-acid battery has an internal resistance of 20 milli-ohms (20 mΩ):

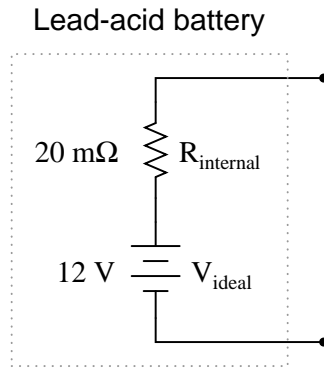

If a short-circuit were placed across the terminals of this large battery, the fault current would be quite large: 600 amps!

Now suppose three of these batteries were connected directly in parallel with one another:

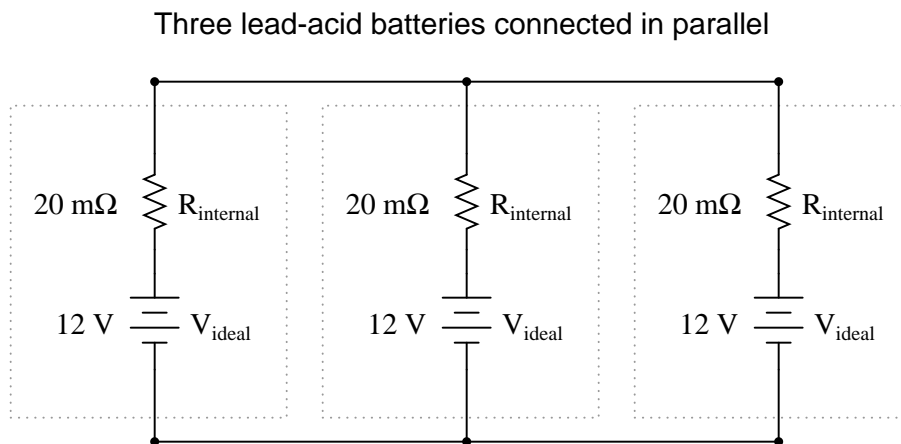

Reduce this network of parallel-connected batteries into either a Thévenin or a Norton equivalent circuit, and then re-calculate the fault current available at the terminals of the three-battery "bank" in the event of a direct short-circuit.

[file 03243](#)

---

Answer 60

$$I_{\text{fault}} = 1800 \text{ amps}$$

Follow-up question: explain what practical importance this question has for parallel-connected batteries, and how either Thévenin's or Norton's theorems makes the concept easier to explain to someone else. What safety issues might be raised by the parallel connection of large batteries such as these?

---

Notes 60

Ask your students whether they used Thévenin's Theorem or Norton's theorem to solve for the fault current. Have students demonstrate the analysis both ways to see which is easiest to understand.

---

Question 61

Convert the following Thévenin equivalent circuit into a Norton equivalent circuit:

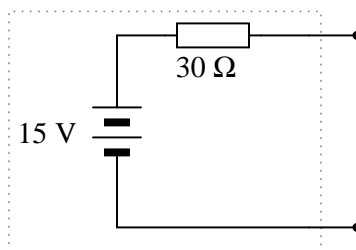

file 03240

---

Answer 61

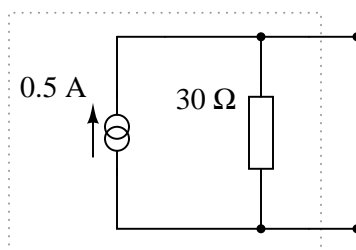

---

Notes 61

Nothing special here, just practice converting between Thevenin and Norton sources. Be sure to ask your students to explain all their steps and reasoning in arriving at the answer.

---

Question 62

Convert the following Norton equivalent circuit into a Thévenin equivalent circuit:

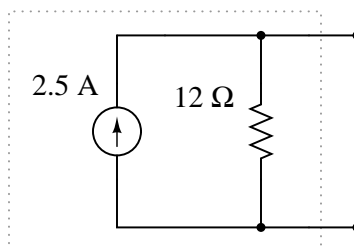

file 02030

---

Answer 62

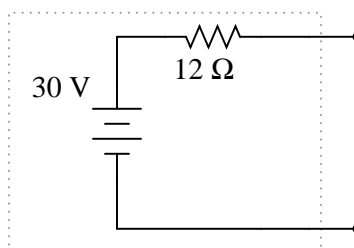

---

Notes 62

Nothing special here, just practice converting between Thevenin and Norton sources. Be sure to ask your students to explain all their steps and reasoning in arriving at the answer.

Question 63

Resistive voltage dividers are very useful and popular circuits. However, it should be realized that their output voltages "sag" under load:

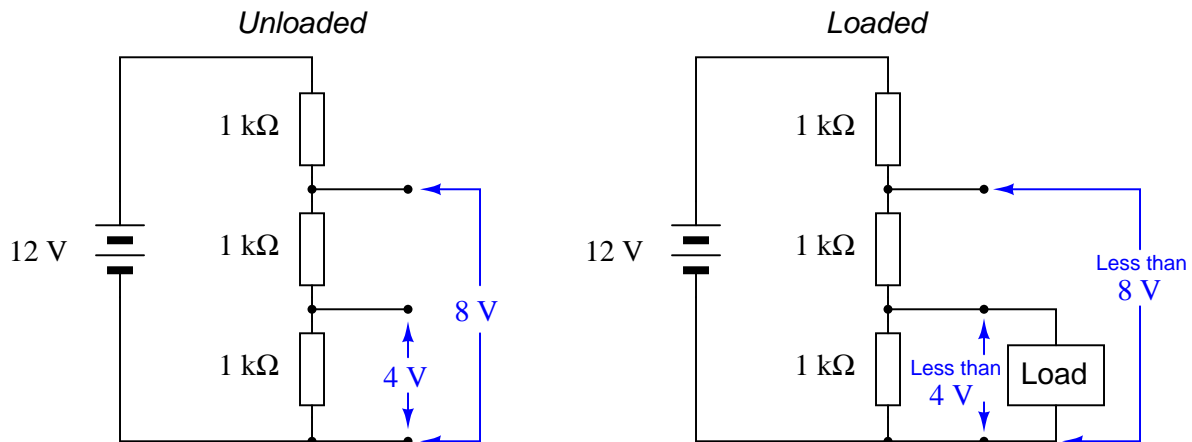

Just how much a voltage divider's output will sag under a given load may be a very important question in some applications. Take for instance the following application where we are using a resistive voltage divider to supply an engine sensor with reduced voltage (8 volts) from the 12 volt battery potential in the automobile:

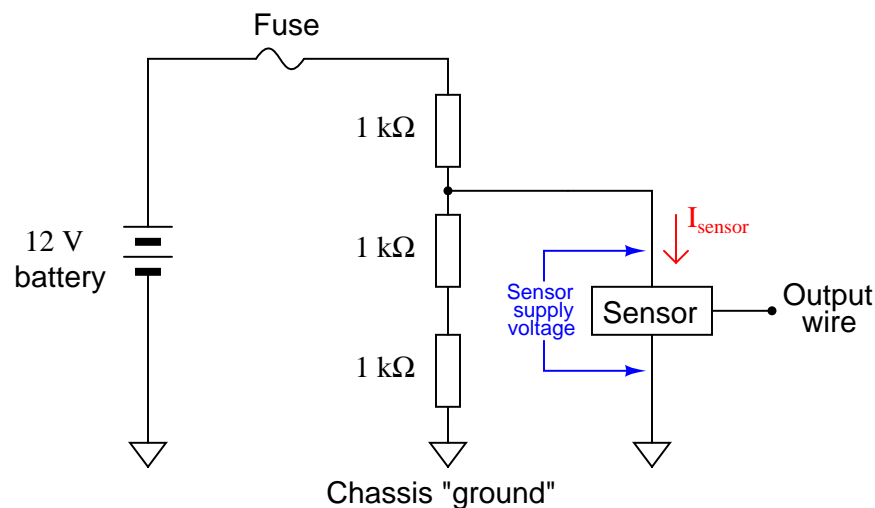

If the sensor draws no current ( $I_{sensor} = 0$  mA), then the voltage across the sensor supply terminals will be 8 volts. However, if we were asked to predict the voltage across the sensor supply terminals for a variety of different sensor current conditions, we would be faced with a much more complex problem:

Sensor current ( $I_{sensor}$ )	Sensor supply voltage
0 mA	8 volts
1 mA	
2 mA	
3 mA	
4 mA	
5 mA	

One technique we could use to simplify this problem is to reduce the voltage divider resistor network into a Thévenin equivalent circuit. With the three-resistor divider reduced to a single resistor in series with an equivalent voltage source, the calculations for sensor supply voltage become much simpler.

Show how this could be done, then complete the table of sensor supply voltages shown above.  
[file 03239](#)

Answer 63

*Thevenin equivalent circuit*

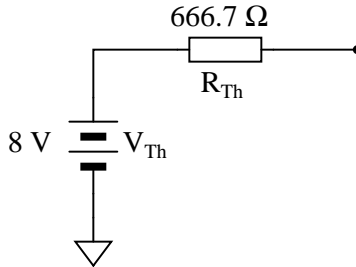

Sensor current ( $I_{sensor}$ )	Sensor supply voltage
0 mA	8 volts
1 mA	7.333 volts
2 mA	6.667 volts
3 mA	6 volts
4 mA	5.333 volts
5 mA	4.667 volts

Follow-up question: if we cannot allow the sensor supply voltage to fall below 6.5 volts, what is the maximum amount of current it may draw from this voltage divider circuit?

Challenge question: figure out how to solve for these same voltage figures without reducing the voltage divider circuit to a Thévenin equivalent.

Notes 63

Students are known to ask, "When are we ever going to use Thévenin's Theorem?" as this concept is introduced in their electronics coursework. This is a valid question, and should be answered with immediate, practical examples. This question does exactly that: demonstrate how to predict voltage "sag" for a loaded voltage divider in such a way that is much easier than using Ohm's Law and Kirchhoff's Laws directly.

Note the usage of European schematic symbols in this question. Nothing significant about this choice – just an opportunity for students to see other ways of drawing schematics.

Note also how this question makes use of ground symbols, but in a way where the concept is introduced gently: the first (example) schematics do not use ground symbols, whereas the practical (automotive) circuit does.

Question 64

One day an electronics student decides to build her own variable-voltage power source using a 6-volt battery and a 10 k $\Omega$  potentiometer:

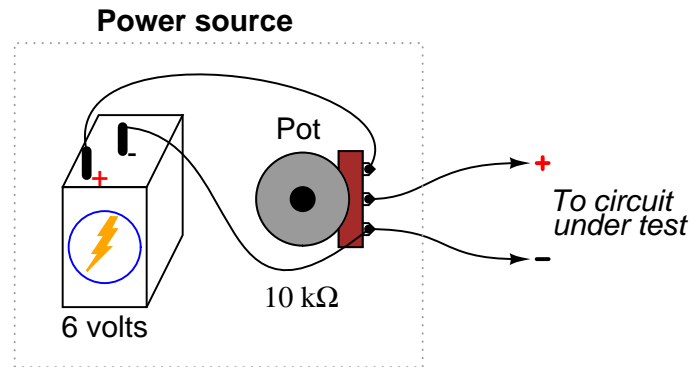

She tests her circuit by connecting a voltmeter to the output terminals and verifying that the voltage does indeed increase and decrease as the potentiometer knob is turned.

Later that day, her instructor assigns a quick lab exercise: measure the current through a parallel resistor circuit with an applied voltage of 3 volts, as shown in the following schematic diagram.

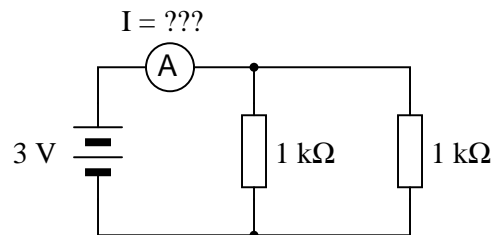

Calculating current in this circuit is a trivial exercise, she thinks to herself:  $3 \text{ V} \div 500 \Omega = 6 \text{ mA}$ . This will be a great opportunity to use the new power source circuit, as 3 volts is well within the voltage adjustment range!

She first sets up her circuit to output 3 volts precisely (turning the 10 k $\Omega$  potentiometer to the 50% position), measuring with her voltmeter as she did when initially testing the circuit. Then she connects the output leads to the two parallel resistors through her multimeter (configured as an ammeter), like this:



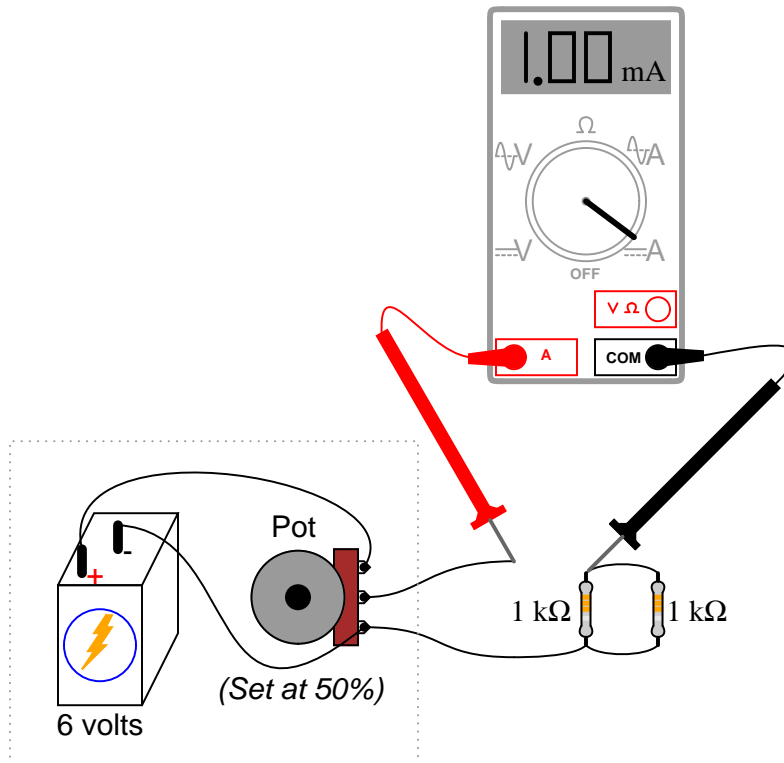

However, when she reads her ammeter display, the current only measures 1 mA, not 6 mA as she predicted. This is a very large discrepancy between her prediction and the measured value for current!

Use Thévenin's Theorem to explain what went wrong in this experiment. Why didn't her circuit behave as she predicted it would?

[file 03238](#)

Answer 64

With the 10 kΩ potentiometer set in the 50% position, this student's power source circuit resembles a 3 volt source in series with a 5 kΩ resistance (the Thévenin equivalent circuit) rather than an ideal 3 volt source as assumed when she made her prediction for circuit current.

Follow-up question #1: explain what this student would have to do to use her adjustable-voltage power source circuit to properly demonstrate the lab circuit as assigned.

Follow-up question #2: identify at least one circuit failure which would result in zero measured (ammeter) current.

Notes 64

This challenges students to apply Thévenin's Theorem to a practical scenario: a loaded voltage divider. Be sure to ask your students to show what the Thévenin equivalent circuit for the student's power source is (set at 50%, or 3 volts output unloaded), and how they arrived at that equivalent circuit.

Question 65

Plot the power dissipation of the load resistance, for several values between 1 k $\Omega$  and 20 k $\Omega$ :

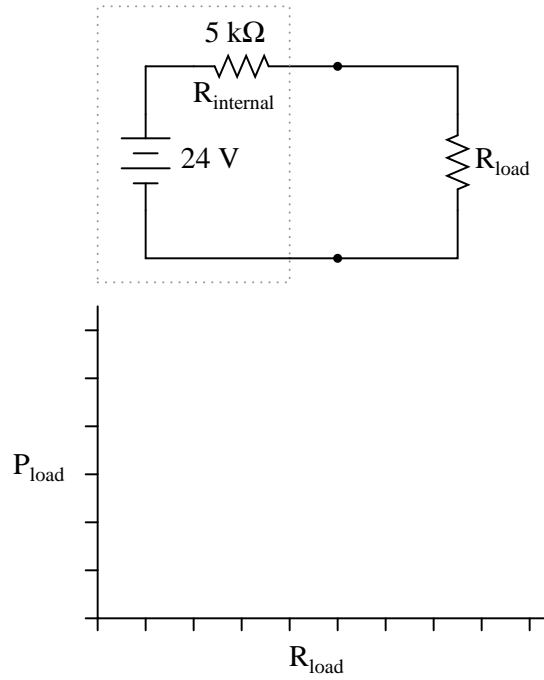

At what load resistance value is the load's power dissipation maximized?

file 00391

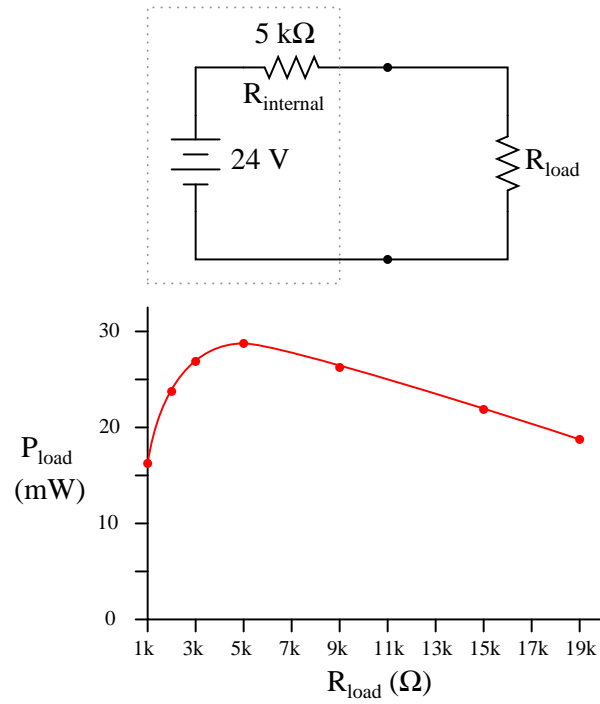

Notes 65

What practical application can you think of for this principle of power maximization? In what applications might we be interested in delivering the maximum amount of power possible to a load?

---

Question 66

Explain what the *Maximum Power Transfer Theorem* is, in your own words.  
[file 01881](#)

---

Answer 66

This I leave to you to research!

---

Notes 66

This theorem is very easy to research, being described in just about every introductory electronics textbook. While it may not be intuitive, at least it is useful and easy to remember!

---

Question 67

At what load resistance value is the power dissipation maximized for the source's internal resistance?

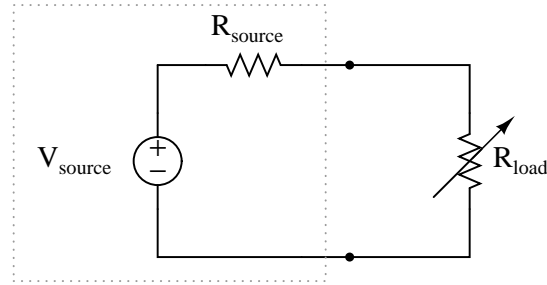

file 02028

---

Answer 67

Source dissipation will be maximized at  $R_{\text{load}} = 0 \Omega$ . Surprised at this answer? Expecting power to be maximized at  $R_{\text{load}} = R_{\text{source}}$ , perhaps? If so, you have misunderstood the Maximum Power Transfer Theorem.

---

Notes 67

The wrong answer anticipated in the "Answer" section reflects a common student misconception, and a tendency to memorize simple rules rather than *think* and analyze circuit behavior. Remind your students that the Maximum Power Transfer Theorem specifies what value the *load* resistance should be at to maximize power dissipation *at that same load*, not elsewhere.

---

Question 68

Explain why it is important for optimum performance to connect speakers of the proper impedance to an audio power amplifier.

file 02027

---

Answer 68

Improper speaker impedance may result in low power output (excessive  $Z$ ) or overheating of the amplifier (insufficient  $Z$ ).

Follow-up question: since consumer-grade audio speakers are typically uniform in impedance ( $8\ \Omega$  is a very popular value), how would it be possible to connect a wrong speaker impedance to an audio power amplifier?

---

Notes 68

I find it typical that students of electronics new to basic electrical theory are fascinated by discussions related to audio technology, as it is difficult to find someone who does not in some way appreciate music. This is a good thing, for the more "real" you can make your students' classroom experience, the better they will learn.

---

Question 69

At what source resistance value is the power dissipation maximized for the load?

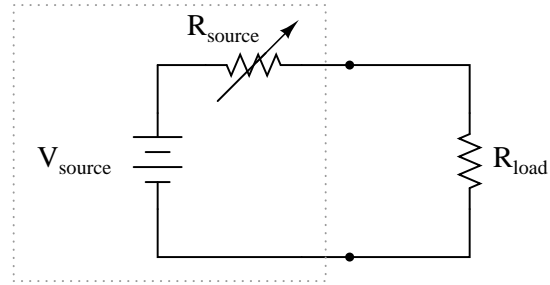

file 02029

---

Answer 69

Source dissipation will be maximized at  $R_{source} = 0 \Omega$ . Surprised at this answer? Expecting power to be maximized at  $R_{source} = R_{load}$ , perhaps? If so, you have misunderstood the Maximum Power Transfer Theorem.

---

Notes 69

The wrong answer anticipated in the "Answer" section reflects a common student misconception, and a tendency to memorize simple rules rather than *think* and analyze circuit behavior. Remind your students that the Maximum Power Transfer Theorem specifies what value the *load* resistance should be at to maximize power dissipation *at that same load*, not elsewhere.

---

Question 70

Suppose we were planning to use a photovoltaic panel to generate electricity and electrolyze water into hydrogen and oxygen gas:

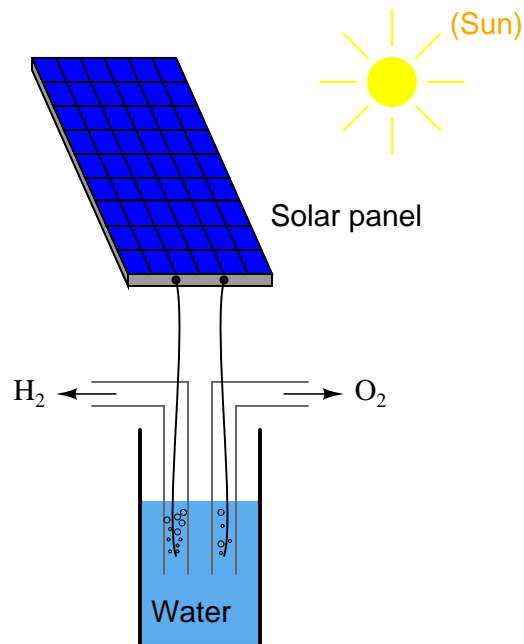

Our goal is to electrolyze as much water as possible, and this means we must maximize the electrolysis cell's power dissipation. Explain how we could experimentally determine the optimum internal resistance of the electrolysis cell, prior to actually building it, using nothing but the solar panel, a rheostat, and a DMM (digital multimeter).

[file 00392](#)

---

Answer 70

Experimentally determine what amount load resistance drops exactly one-half of the panel's open-circuit voltage.

Follow-up question: assuming that the open-circuit voltage of this solar panel were high enough to pose a shock hazard, describe a procedure you might use to safely connect a "test load" to the panel.

---

Notes 70

Students should at this point understand the maximum power transfer theorem, and also the concept of a voltage source having a certain amount of internal resistance. The "trick" of this question is, of course, how to determine the panel's internal resistance. Do not be surprised if a student suggests using the meter to measure the panel's resistance directly (though this will not work with a real photovoltaic panel).

Regarding the safety-oriented follow-up question, you might want to ask your students what the commonly accepted "shock hazard" voltage level is (30 volts).

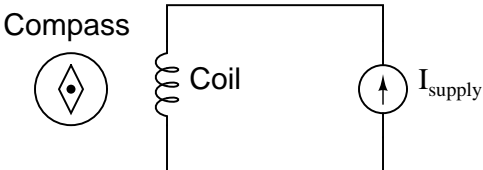

Competency: <b>Electromagnetism</b>	Version:															
<b>Schematic</b>																
 <p>The diagram shows a rectangular circuit loop. On the left side, there is a coil of wire labeled 'Coil'. On the right side, there is a power supply symbol labeled 'I<sub>supply</sub>' with an upward-pointing arrow. To the left of the coil is a compass symbol, consisting of a circle with a diamond inside and a dot at the center, labeled 'Compass'.</p>																
<b>Given conditions</b>																
<p>Vary the power supply current, and also switch polarity, noting the effects on the compass needle.</p>																
<b>Parameters</b>																
<i>Qualitative answers only</i>																
	<table border="1" style="margin-left: auto; margin-right: auto;"> <thead> <tr> <th style="padding: 5px;"></th> <th style="padding: 5px;">Predicted</th> <th style="padding: 5px;">Measured</th> </tr> </thead> <tbody> <tr> <td style="padding: 5px;">Low current</td> <td style="width: 60px; height: 20px;"></td> <td style="width: 60px; height: 20px;"></td> </tr> <tr> <td style="padding: 5px;">Higher current</td> <td style="width: 60px; height: 20px;"></td> <td style="width: 60px; height: 20px;"></td> </tr> <tr> <td style="padding: 5px;">Reverse polarity Low current</td> <td style="width: 60px; height: 20px;"></td> <td style="width: 60px; height: 20px;"></td> </tr> <tr> <td style="padding: 5px;">Reverse polarity Higher current</td> <td style="width: 60px; height: 20px;"></td> <td style="width: 60px; height: 20px;"></td> </tr> </tbody> </table>		Predicted	Measured	Low current			Higher current			Reverse polarity Low current			Reverse polarity Higher current		
	Predicted	Measured														
Low current																
Higher current																
Reverse polarity Low current																
Reverse polarity Higher current																
<b>Analysis</b>																
<p>Identify the places on the coil where the field is strongest.</p>																

file 01645

---

### Answer 71

I won't reveal the answer here as to what effect magnitude has on magnetic field strength, but I will suggest a way to test for strength: place the compass at a distance from the coil, where the coil's field has a relatively small effect on the needle position in relation to the ambient magnetic field.

---

### Notes 71

Electromagnetism is a fundamental "first principle" with a wide range of applications including electric motors, relays, and solenoid actuators.

Old solenoid valve coils work very well for this exercise, as do spools of wire with large steel bolts passed through the center. Students may also wind their own coils using small-gauge magnet wire and a steel bolt. If the coils are hollow, you may experiment with and without ferrous cores, to demonstrate the effects of a ferromagnetic flux path on the field strength produced.

#### **General concepts and principles to emphasize**

- The "right-hand rule" for relating direction of current, geometry of wire, and direction of magnetic field

#### **Suggestions for Socratic discussion and experimentation**

- Identify ways to increase the magnetic field strength without altering the amount of electric current through the wire coil.
- Will a reversal of current affect how well the electromagnet coil attracts plain iron and steel objects, or does this reversal only affect how a compass reads the field?
- Will a reversal in the direction the wire is wound in a coil affect how well the electromagnet coil attracts plain iron and steel objects, or does this reversal only affect how a compass reads the field?

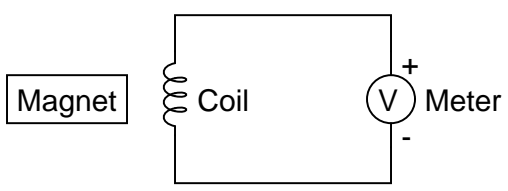
Competency: <b>Electromagnetic induction</b>	Version:															
<b>Schematic</b>																
																
<b>Given conditions</b>																
<p>Set voltmeter to the most sensitive range possible!</p> <p>Move the magnet slowly toward the coil, and then slowly away</p> <p>Move the magnet quickly toward the coil, and then quickly away</p>																
<b>Parameters</b>																
<i>Qualitative answers only</i>																
	<table border="1" style="margin-left: auto; margin-right: auto;"> <thead> <tr> <th style="width: 15%;"></th> <th style="width: 20%;">Predicted</th> <th style="width: 20%;">Measured</th> </tr> </thead> <tbody> <tr> <td style="text-align: center;"><math>V_{\text{coil}}</math> Slowly, toward</td> <td style="width: 50px; height: 20px;"></td> <td style="width: 50px; height: 20px;"></td> </tr> <tr> <td style="text-align: center;"><math>V_{\text{coil}}</math> Slowly, away</td> <td style="width: 50px; height: 20px;"></td> <td style="width: 50px; height: 20px;"></td> </tr> <tr> <td style="text-align: center;"><math>V_{\text{coil}}</math> Quickly, toward</td> <td style="width: 50px; height: 20px;"></td> <td style="width: 50px; height: 20px;"></td> </tr> <tr> <td style="text-align: center;"><math>V_{\text{coil}}</math> Quickly, away</td> <td style="width: 50px; height: 20px;"></td> <td style="width: 50px; height: 20px;"></td> </tr> </tbody> </table>		Predicted	Measured	$V_{\text{coil}}$ Slowly, toward			$V_{\text{coil}}$ Slowly, away			$V_{\text{coil}}$ Quickly, toward			$V_{\text{coil}}$ Quickly, away		
	Predicted	Measured														
$V_{\text{coil}}$ Slowly, toward																
$V_{\text{coil}}$ Slowly, away																
$V_{\text{coil}}$ Quickly, toward																
$V_{\text{coil}}$ Quickly, away																
<b>Analysis</b>																
<p>Does the orientation of the magnet have any effect on the polarity or magnitude of the induced voltage?</p> <p>Does the direction of approach to the coil have any effect on the magnitude of the induced voltage?</p>																

[file 01644](#)

---

## Answer 72

The magnitude of the induced voltage is a direct function of the magnetic flux's rate of change over time ( $\frac{d\phi}{dt}$ ).

---

## Notes 72

Electromagnetic induction is a fundamental “first principle” with a wide range of applications including electric generators, sensors, and power transformers.

Old solenoid valve coils work very well for this exercise, as do spools of wire with large steel bolts passed through the center. Students may also wind their own coils using small-gauge magnet wire and a steel bolt.

Please note that students will not be able to *predict* the polarity of the induced voltage unless they know the rotation of the coil windings and the polarity of their magnet. This will only be possible if the windings are exposed to view or if the students wind their own coils, and if the magnet has its poles labeled “North” and “South” (or if this is determined experimentally by using the magnet as a compass).

Use magnets that are as strong as possible, and that have their poles on the physical ends. This may seem like a strange request, but I've seen students bring some unusual magnets to class for this experiment, whose poles are *not* located on the ends. One type of magnet that works well is the so-called “cow magnet,” used by cattle ranchers to protect cows' multiple stomachs from injury from ingestion of fence staples and other ferromagnetic objects. These are a few inches long, cylindrical in shape (so the cow can swallow it like a big pill), and quite strong.

If students are using analog multimeters to measure the coil's induced voltage, be sure to keep the multimeter far away from the magnet. Analog meter movements are generally quite sensitive to external magnetic fields and may register falsely if positioned too close to a strong magnet.

### General concepts and principles to emphasize

- Faraday's Law of electromagnetic induction:  $E = N \frac{d\phi}{dt}$
- Lenz's Law (that the direction of induced current tends to oppose the instigating change)

### Suggestions for Socratic discussion and experimentation

- Identify ways to increase the induced voltage without using a stronger magnet.
- Will a reversal in the direction the wire is wound in a coil affect the polarity of the induced voltage, the magnitude of the induced voltage, or both?
- A technique used in making wire-wound resistors is something called a *bifilar winding*. Bifilar windings have nearly zero inductance. Research how a bifilar winding is made, and then explain how it works to minimize induction and also why this might be important for making resistors.

Competency: <b>Thevenin's theorem</b>	Version:		
<b>Schematic</b>			
<p><i>Original circuit</i></p>	<p><i>Thevenin equivalent circuit</i></p>		
<b>Given conditions</b>			
$V_{\text{supply}} =$	$R_1 =$	$R_2 =$	$R_{\text{load}} =$
	$R_3 =$	$R_4 =$	
<b>Parameters</b>			
<b>Predicted</b>			
$V_{\text{thevenin}}$	<input style="width: 100%;" type="text"/>		
$R_{\text{thevenin}}$	<input style="width: 100%;" type="text"/>		
<b>Measured (in original circuit)</b>		<b>Measured (in Thevenin equivalent circuit)</b>	
$V_{\text{load}}$	<input style="width: 100%;" type="text"/>	<input style="width: 100%;" type="text"/>	

Use circuit simulation software to verify your predicted and measured parameter values.

---

Notes 73

Thevenin's Theorem is tremendously useful for analyzing the performance of complex circuit networks. In particular, it is useful in transistor amplifier circuit design and analysis. Its power lies in the ability to reduce the complexity of a large network into nothing more than an equivalent voltage source and series resistance.

Use a variable-voltage, regulated power supply for  $V_{thevenin}$ , and a fixed-voltage supply for  $V_{source}$ . Specify standard resistor values, all between 1 k $\Omega$  and 100 k $\Omega$  (1k5, 2k2, 2k7, 3k3, 4k7, 5k1, 6k8, 10k, 22k, 33k, 39k 47k, 68k, etc.) for resistors in the original circuit. A decade box or potentiometer will suffice for  $R_{thevenin}$ .

In case it is not already crystal-clear, I want students to build *two different circuits* for this exercise: the "original" circuit and also a "Thevenin equivalent" circuit, then plug the exact same load resistor into both circuits (one at a time) to see that the voltage across it is the same in both cases. Many students seem to struggle with the basic concept of equivalent circuits, and I have found this exercise (once successfully completed) to be excellent for "making it real" to these students.

An extension of this exercise is to incorporate troubleshooting questions. Whether using this exercise as a performance assessment or simply as a concept-building lab, you might want to follow up your students' results by asking them to predict the consequences of certain circuit faults.

**General concepts and principles to emphasize**

- The internal resistance of ideal voltage sources (zero)
- The internal resistance of ideal current sources (infinite)
- Calculating the total resistance of a series-parallel resistor network
- Re-drawing circuits in simplified form as part of the analysis technique

**Suggestions for Socratic discussion and experimentation**

- Identify at least *two* different resistance values you could change in the original circuit to increase the Thevenin equivalent resistance as seen from the perspective of the load.
- Identify at least *two* different resistance values you could change in the original circuit to increase the Thevenin equivalent voltage as seen from the perspective of the load.
- Will an increase in Thevenin equivalent resistance result in a "firmer" or "softer" power source to the load (i.e. will the voltage delivered to the load be less or more dependent on how much current the load draws)?

Competency: <b>Loaded voltage divider</b>	Version:																																
<b>Schematic</b>																																	
<b>Given conditions</b>																																	
$V_{\text{supply}} =$ $R_1 =$ $R_2 =$ $R_3 =$ $R_{\text{load1}} =$ $R_{\text{load2}} =$																																	
<b>Parameters</b>																																	
<table style="width: 100%; border-collapse: collapse;"> <thead> <tr> <th style="width: 15%;"></th> <th style="width: 25%; text-align: center;">Predicted</th> <th style="width: 25%; text-align: center;">Measured</th> <th style="width: 15%;"></th> <th style="width: 20%;"></th> </tr> </thead> <tbody> <tr> <td style="vertical-align: middle;"><math>I_{\text{supply}}</math></td> <td style="text-align: center;"><input type="text"/></td> <td style="text-align: center;"><input type="text"/></td> <td style="vertical-align: middle;"><math>I_{\text{load1}}</math></td> <td style="text-align: center;"><input type="text"/></td> </tr> <tr> <td style="vertical-align: middle;"><math>V_A</math></td> <td style="text-align: center;"><input type="text"/></td> <td style="text-align: center;"><input type="text"/></td> <td style="vertical-align: middle;"><math>I_{\text{load2}}</math></td> <td style="text-align: center;"><input type="text"/></td> </tr> <tr> <td style="vertical-align: middle;"><math>V_B</math></td> <td style="text-align: center;"><input type="text"/></td> <td style="text-align: center;"><input type="text"/></td> <td style="vertical-align: middle;"><math>I_{\text{bleed}}</math></td> <td style="text-align: center;"><input type="text"/></td> </tr> </tbody> </table>		Predicted	Measured			$I_{\text{supply}}$	<input type="text"/>	<input type="text"/>	$I_{\text{load1}}$	<input type="text"/>	$V_A$	<input type="text"/>	<input type="text"/>	$I_{\text{load2}}$	<input type="text"/>	$V_B$	<input type="text"/>	<input type="text"/>	$I_{\text{bleed}}$	<input type="text"/>	<table style="width: 100%; border-collapse: collapse;"> <thead> <tr> <th style="width: 15%;"></th> <th style="width: 25%; text-align: center;">Predicted</th> <th style="width: 25%; text-align: center;">Measured</th> </tr> </thead> <tbody> <tr> <td style="vertical-align: middle;"><math>I_{\text{load1}}</math></td> <td style="text-align: center;"><input type="text"/></td> <td style="text-align: center;"><input type="text"/></td> </tr> <tr> <td style="vertical-align: middle;"><math>I_{\text{load2}}</math></td> <td style="text-align: center;"><input type="text"/></td> <td style="text-align: center;"><input type="text"/></td> </tr> <tr> <td style="vertical-align: middle;"><math>I_{\text{bleed}}</math></td> <td style="text-align: center;"><input type="text"/></td> <td style="text-align: center;"><input type="text"/></td> </tr> </tbody> </table>		Predicted	Measured	$I_{\text{load1}}$	<input type="text"/>	<input type="text"/>	$I_{\text{load2}}$	<input type="text"/>	<input type="text"/>	$I_{\text{bleed}}$	<input type="text"/>	<input type="text"/>
	Predicted	Measured																															
$I_{\text{supply}}$	<input type="text"/>	<input type="text"/>	$I_{\text{load1}}$	<input type="text"/>																													
$V_A$	<input type="text"/>	<input type="text"/>	$I_{\text{load2}}$	<input type="text"/>																													
$V_B$	<input type="text"/>	<input type="text"/>	$I_{\text{bleed}}$	<input type="text"/>																													
	Predicted	Measured																															
$I_{\text{load1}}$	<input type="text"/>	<input type="text"/>																															
$I_{\text{load2}}$	<input type="text"/>	<input type="text"/>																															
$I_{\text{bleed}}$	<input type="text"/>	<input type="text"/>																															
<b>Fault analysis</b>																																	
<p>Suppose component <input style="width: 40px;" type="text"/> fails <input type="checkbox"/> open    <input type="checkbox"/> other _____  <input type="checkbox"/> shorted</p> <p><i>What will happen in the circuit? Write "increase", "decrease", or "no change" for each parameter:</i></p> <table style="width: 100%; border-collapse: collapse;"> <tr> <td style="width: 33%;"><math>V_A</math> <input style="width: 100px;" type="text"/></td> <td style="width: 33%;"><math>I_{\text{load1}}</math> <input style="width: 100px;" type="text"/></td> <td style="width: 33%;"><math>I_{\text{bleed}}</math> <input style="width: 100px;" type="text"/></td> </tr> <tr> <td><math>V_B</math> <input style="width: 100px;" type="text"/></td> <td><math>I_{\text{load2}}</math> <input style="width: 100px;" type="text"/></td> <td></td> </tr> </table>		$V_A$ <input style="width: 100px;" type="text"/>	$I_{\text{load1}}$ <input style="width: 100px;" type="text"/>	$I_{\text{bleed}}$ <input style="width: 100px;" type="text"/>	$V_B$ <input style="width: 100px;" type="text"/>	$I_{\text{load2}}$ <input style="width: 100px;" type="text"/>																											
$V_A$ <input style="width: 100px;" type="text"/>	$I_{\text{load1}}$ <input style="width: 100px;" type="text"/>	$I_{\text{bleed}}$ <input style="width: 100px;" type="text"/>																															
$V_B$ <input style="width: 100px;" type="text"/>	$I_{\text{load2}}$ <input style="width: 100px;" type="text"/>																																

Use circuit simulation software to verify your predicted and measured parameter values.

---

Use a variable-voltage, regulated power supply to supply any amount of DC voltage below 30 volts. Specify standard resistor values, all between 1 k $\Omega$  and 100 k $\Omega$  (1k5, 2k2, 2k7, 3k3, 4k7, 5k1, 6k8, 8k2, 10k, 22k, 33k, 39k, 47k, 68k, 82k, etc.).

I have used this circuit as both a "quick" lab exercise and a troubleshooting exercise, using values of 10 k $\Omega$  for R1, R2, and R3; 15 k $\Omega$  for R(load1); 22 k $\Omega$  for R(load2); and 6 volts for the power supply. Of course, these component values are not critical, but they do provide easy-to-measure voltages and currents without incurring excessive impedances that would cause significant voltmeter loading problems.

An extension of this exercise is to incorporate troubleshooting questions. Whether using this exercise as a performance assessment or simply as a concept-building lab, you might want to follow up your students' results by asking them to predict the consequences of certain circuit faults.

#### General concepts and principles to emphasize

- Voltage is a *differential* quantity: always measured between two points
- Continuous current must be the same through all series-connected components
- Voltage must be the same across all parallel-connected components
- The distinction between electrical *sources* and electrical *loads*
- Qualitative analysis using Ohm's Law (i.e. how to analyze *increases* and *decreases* without the use of numerical quantities)

#### Suggestions for Socratic discussion and experimentation

- Sketch the direction of current in this circuit. Also sketch the + and – symbols marking voltage polarity across each component in the circuit. Explain why the relationship between the power supply's voltage polarity and current direction is different than the relationship between each resistor's voltage polarity and current direction. Identify whether each of the components in this circuit is an electrical *source* or an electrical *load*.
- If just one of the load resistor's resistance happens to increase, how will this change affect the voltage seen by the other load?
- If just one of the voltage divider resistor's resistance happens to increase, how will this change affect the voltage seen by the two loads?
- If the power supply's voltage happens to increase, how will this change affect all the other electrical quantities in the circuit?
- Not all voltage divider circuits behave the same when loaded. For example two different divider circuits, each one dividing the source voltage into thirds (i.e. 66%, 33%), may yield the exact same output voltages with no loads attached, but as soon as equal loads are attached to them their output voltages "sag" to different degrees. Explain why this happens, and what is it about the more "stout" voltage divider circuit that allows it to better maintain its ideal output voltage under load.





---

Answer 75

I do not provide a grading rubric here, but elsewhere.

---

Notes 75

The idea of a troubleshooting log is three-fold. First, it gets students in the habit of documenting their troubleshooting procedure and thought process. This is a valuable habit to get into, as it translates to more efficient (and easier-followed) troubleshooting on the job. Second, it provides a way to document student steps for the assessment process, making your job as an instructor easier. Third, it reinforces the notion that each and every measurement or action should be followed by reflection (conclusion), making the troubleshooting process more efficient.

---

Question 76

NAME: \_\_\_\_\_ **Troubleshooting Grading Criteria**

You will receive the highest score for which *all* criteria are met.

100 % (*Must meet or exceed all criteria listed*)

- A. Absolutely flawless procedure
- B. No unnecessary actions or measurements taken

90 % (*Must meet or exceed these criteria in addition to all criteria for 85% and below*)

- A. No reversals in procedure (i.e. changing mind without sufficient evidence)
- B. Every single action, measurement, and relevant observation properly documented

80 % (*Must meet or exceed these criteria in addition to all criteria for 75% and below*)

- A. No more than one unnecessary action or measurement
- B. No false conclusions or conceptual errors
- C. No missing conclusions (i.e. at least one documented conclusion for action / measurement / observation)

70 % (*Must meet or exceed these criteria in addition to all criteria for 65%*)

- A. No more than one false conclusion or conceptual error
- B. No more than one conclusion missing (i.e. an action, measurement, or relevant observation without a corresponding conclusion)

65 % (*Must meet or exceed these criteria in addition to all criteria for 60%*)

- A. No more than two false conclusions or conceptual errors
- B. No more than two unnecessary actions or measurements
- C. No more than one undocumented action, measurement, or relevant observation
- D. Proper use of all test equipment

60 % (*Must meet or exceed these criteria*)

- A. Fault accurately identified
- B. Safe procedures used at all times

50 % (*Only applicable where students performed significant development/design work – i.e. not a proven circuit provided with all component values*)

- A. Working prototype circuit built and demonstrated

0 % (*If any of the following conditions are true*)

- A. Unsafe procedure(s) used at any point

file 03932

---

Answer 76

Be sure to document all steps taken and conclusions made in your troubleshooting!

---

Notes 76

The purpose of this assessment rubric is to act as a sort of “contract” between you (the instructor) and your student. This way, the expectations are all clearly known in advance, which goes a long way toward disarming problems later when it is time to grade.

---

Question 77

Describe the so-called "domain theory" of magnetism, as it applies to permanent magnets.  
[file 00624](#)

---

Answer 77

I'll let you research the answer to this question!

---

Notes 77

First, ask your students what a "permanent" magnet is. Are there other kinds of magnets? If so, what might they be called?

One of the more interesting applications of domain theory is *bubble memory*, a type of computer memory technology making use of localized "bubbles" of magnetism in a material corresponding to discrete magnetic domains. You might want to bring this up in discussion, if none of your students do it first.

---

Question 78

A mechanic visits you one day, carrying a large wrench. She says the wrench became magnetized after setting it near a large magnet. Now the wrench has become an annoyance, attracting all the other tools in her toolbox toward it. Can you think of a way to *demagnetize* the wrench for her?

file 00630

---

Answer 78

An object may be de-magnetized by careful magnetization in the opposite direction. Incidentally, this is generally *not* how de-magnetization is done in industry, but it is valid.

---

Notes 78

Students may want to test their hypotheses on magnetized paper clips, which are easy to work with and quite inexpensive. It will be interesting to see how many of your students actually researched modern de-magnetization techniques in preparation for answering this question.

---

Question 79

Suppose we needed to shield a sensitive electronic instrument from external magnetic fields. How would you suggest we do such a thing? How can we keep stray magnetic fields away from this instrument?

[file 00656](#)

---

Answer 79

Magnetic shielding requires that the instrument be completely surrounded by a high-permeability enclosure, such that the enclosure will "conduct" any and all magnetic lines of flux away from the instrument.

Challenge question: should the enclosure material have a high *retentivity*, or a low retentivity? Explain your answer.

---

Notes 79

This question provides a good review of the terms "permeability" and "retentivity". Discuss these terms as they apply to the subject of magnetic shielding. After discussing these concepts, ask your students to give examples of suitable enclosure materials. What metals would be especially good for shielding purposes? Where did they obtain their information about magnetic shielding?

Question 80

A very useful method of measuring current through a wire is to measure the strength of the magnetic field around it. This type of ammeter is known as a *clamp-on* ammeter:

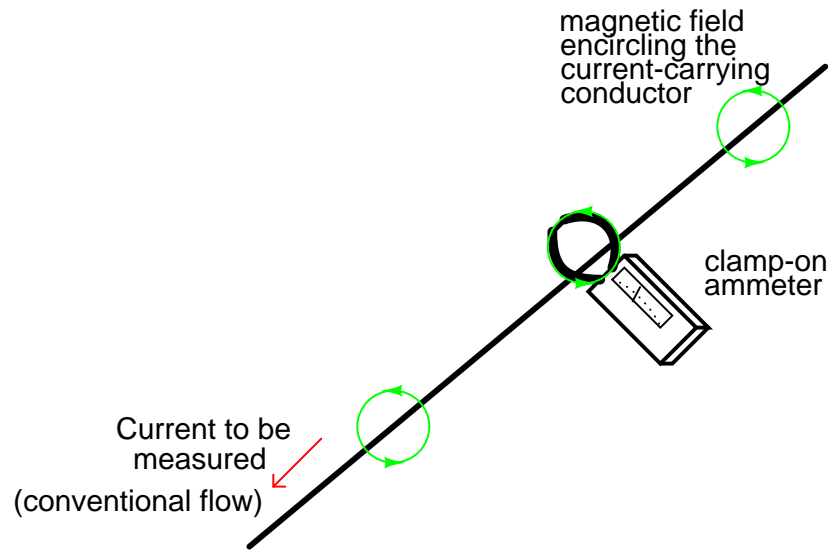

Knowing the principle behind this meter's operation, describe what current values will be indicated by the three clamp-on ammeters in this circuit:

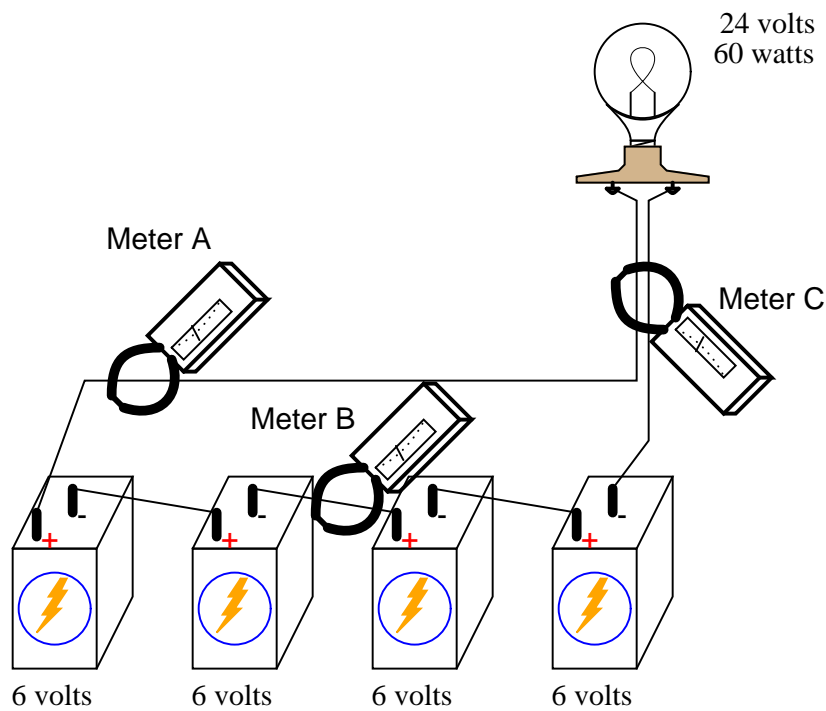

- Meter A =
- Meter B =
- Meter C =

file 00262

---

Answer 80

- Meter A = 2.5 amps
- Meter B = 2.5 amps
- Meter C = 0 amps

---

Notes 80

Clamp-on meters are very useful pieces of test equipment, but they must be used properly. I have seen many people make the mistake of clamping one of these ammeters around multiple wires when trying to measure the amount of current through only one. If you have any clamp-on meters in your classroom, have your students set up a simple circuit like this and prove the validity of the concept.



---

Question 81

When engineers and physicists draw pictures illustrating the magnetic field produced by a straight current-carrying wire, they usually do so using this notation:

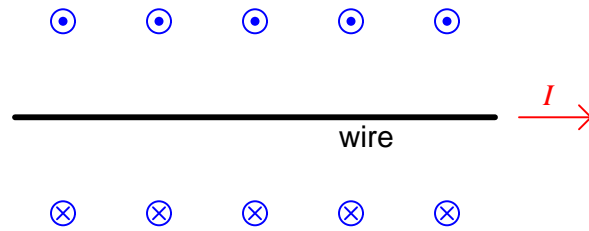

Explain what the circle-and-dot and circle-and-cross symbols mean, with reference to the *right-hand rule*.

[file 03498](#)

---

Answer 81

The circles with dots show the magnetic flux vectors coming at you from out of the paper. The circles with crosses show the magnetic flux vectors going away from you into the paper. Think of these as images of arrows with points (dots) and fletchings (crosses).

---

Notes 81

As a follow-up to this question, you might wish to draw current-carrying wires at different angles, and with current moving in different directions, as practice problems for your students to draw the corresponding arrow points and tails.

---

Question 82

Calculate the reluctance ( $\mathfrak{R}$ ) for a magnetic circuit where the MMF ( $\mathcal{F}$ ) is 8.9 amp-turns and the flux ( $\Phi$ ) is 0.24 webers.

[file 03494](#)

---

Answer 82

$\mathfrak{R} = 37.08$  amp-turns per weber (At/Wb)

---

Notes 82

Nothing special here, just a simple calculation. One of the points of this question is to have students research Rowland's Law and learn how to use it as they would Ohm's Law.

---

Question 83

Calculate the amount of magnetic flux ( $\Phi$ ) in a piece of iron with a reluctance ( $\mathfrak{R}$ ) of 55 amp-turns per weber and an applied MMF ( $\mathcal{F}$ ) of 2.2 amp-turns.

file 03495

---

Answer 83

$$\Phi = 40 \text{ mWb}$$

---

Notes 83

Nothing special here, just a simple calculation. One of the points of this question is to have students research Rowland's Law and learn how to use it as they would Ohm's Law.

Note that the unit abbreviation for "webers" contains two letters, not just one as is the case for most unit abbreviations!

---

Question 84

Calculate the amount of magnetomotive force (MMF, or  $\mathcal{F}$ ) required to establish a magnetic flux ( $\Phi$ ) of  $30 \mu\text{Wb}$  in a piece of iron having a reluctance ( $\mathcal{R}$ ) of  $14 \text{ At/Wb}$ .

file 03496

---

Answer 84

$$\mathcal{F} = 420 \mu\text{At}$$

---

Notes 84

Nothing special here, just a simple calculation. One of the points of this question is to have students research Rowland's Law and learn how to use it as they would Ohm's Law.

Note that the unit abbreviation for "webers" contains two letters, not just one as is the case for most unit abbreviations!

---

Question 85

Calculate the amount of MMF ( $\mathcal{F}$ ) generated by a coil of wire having 1300 turns and carrying 3.5 milliamperes of current.

file 03491

---

Answer 85

$$\mathcal{F} = 4.55 \text{ amp-turns}$$

---

Notes 85

Nothing special here, just a simple calculation. One of the points of this question is to have students research the formula for calculating  $\mathcal{F}$ , as simple as it is.

---

Question 86

Calculate the number of "turns" (wraps) a wire coil would need in order to produce an MMF ( $\mathcal{F}$ ) of 5.7 amp-turns with an electric current of 12 mA.

file 03493

---

Answer 86

$$N = 475 \text{ turns}$$

---

Notes 86

Nothing special here, just a simple calculation. One of the points of this question is to have students research the formula for calculating  $\mathcal{F}$ , as simple as it is.

---

Question 87

Calculate the amount of electric current that would have to pass through a coil of wire having 850 turns to produce an MMF ( $\mathcal{F}$ ) of 2.1 amp-turns.

[file 03492](#)

---

Answer 87

$$I = 2.471 \text{ mA}$$

---

Notes 87

Nothing special here, just a simple calculation. One of the points of this question is to have students research the formula for calculating  $\mathcal{F}$ , as simple as it is.

---

Question 88

The formula for calculating the reluctance ( $\mathfrak{R}$ ) of an air-core wire coil ("solenoid") is as follows:

$$\mathfrak{R} = \frac{l}{\mu_0 A}$$

Where,

$l$  = linear length of coil in meters (m)

$A$  = cross-sectional area of coil "throat" in square meters ( $\text{m}^2$ )

$\mu_0$  = permeability of free space =  $4\pi \times 10^{-7}$  (T·m/A)

Using this formula and the Rowland's Law formula, calculate the amount of magnetic flux ( $\Phi$ ) produced in the throat of an air-core solenoid with 250 turns of wire, a length of 0.2 meters, a cross-sectional area of  $6.5 \times 10^{-4}$  square meters, and a coil current of 5 amps:

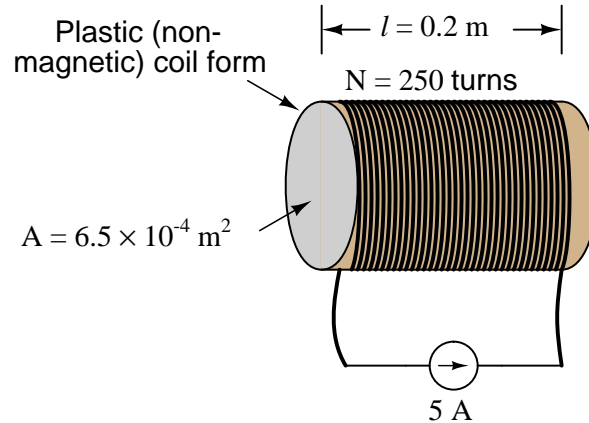

file 03497

---

Answer 88

$$\Phi = 5.105 \mu\text{Wb}$$

---

Notes 88

With all the information given, this is nothing more than an exercise in calculation. However, it is nice for students to have the air-core solenoid reluctance formula handy for other calculations, which is the main point of this question.



---

Question 89

$\int f(x) dx$  *Calculus alert!*

Plot the relative B-H curves for a sample of air and a sample of iron, in proportion to each other (as much as possible):

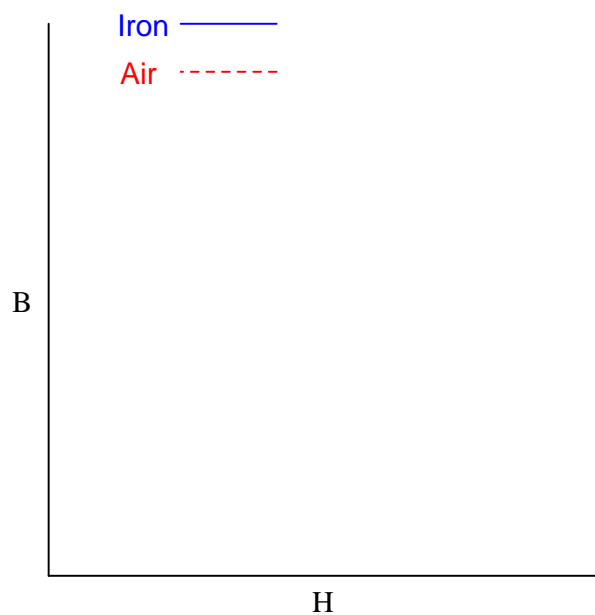

What do you notice about the slope (also called the derivative, or  $\frac{dB}{dH}$ ) of each plot?  
[file 03515](#)

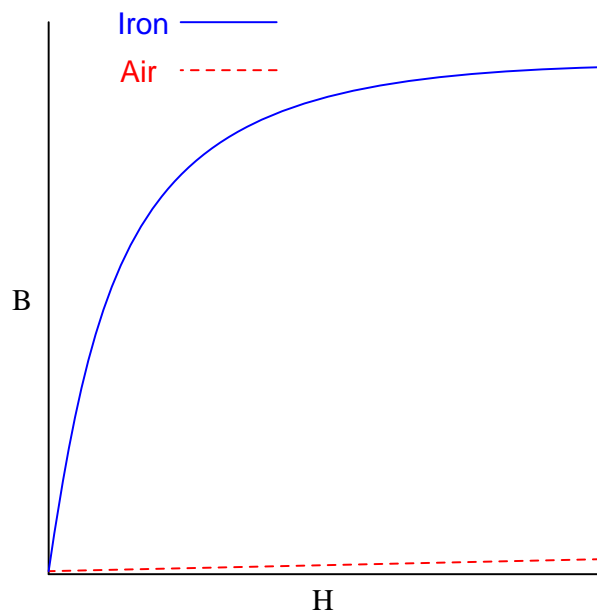

Follow-up question: note that the slope of both plots are approximately equal toward the far right end of the graph. Explain this effect in terms of magnetic *saturation*.

Notes 89

The purpose of this question is twofold: to get students to see that a ferromagnetic material such as iron is *much* more permeable (less "reluctant") than air, but that the great gains in  $B$  realized by iron tend to disappear as soon as saturation sets in. Once the iron is saturated, the gains in  $B$  for equal advances in  $H$  are the same as for air. That is, the  $\frac{dB}{dH}$  for iron is equal to the  $\frac{dB}{dH}$  for air once the iron is saturated.

---

Question 90

If an electric current is passed through this wire, which direction will the wire be pushed (by the interaction of the magnetic fields)?

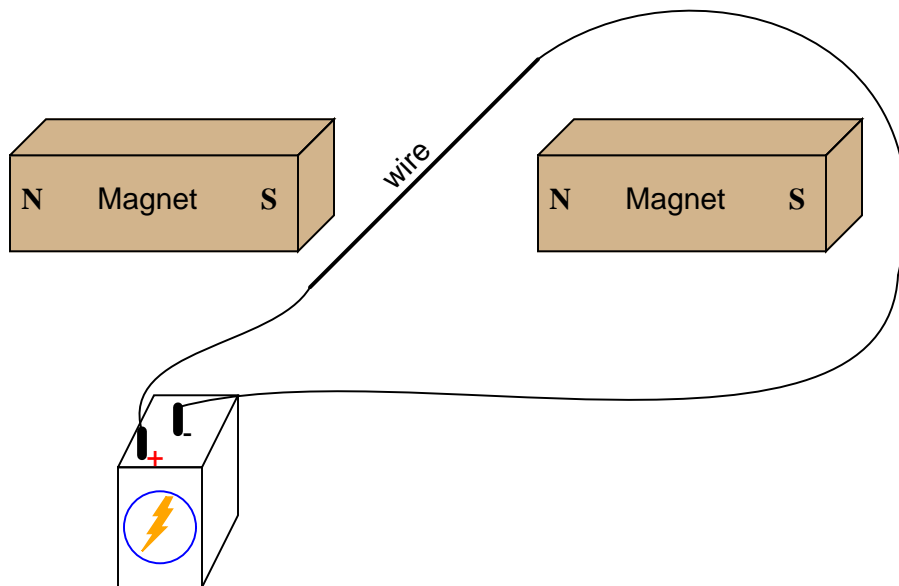

Is this an example of an electric *motor* or an electric *generator*?  
[file 00382](#)

---

Answer 90

The wire will be pushed *up* in this *motor* example.

---

Notes 90

A visual aid to understanding the interaction of the two magnetic fields is a diagram showing the lines of flux emanating from the permanent magnets, against the circular lines of flux around the wire. Ask those students who came across similar illustrations in their research to draw a picture of this on the board in front of the class, for those who have not seen it.

---

Question 91

If an electric current is passed through this wire loop, in which position will it try to orient itself?

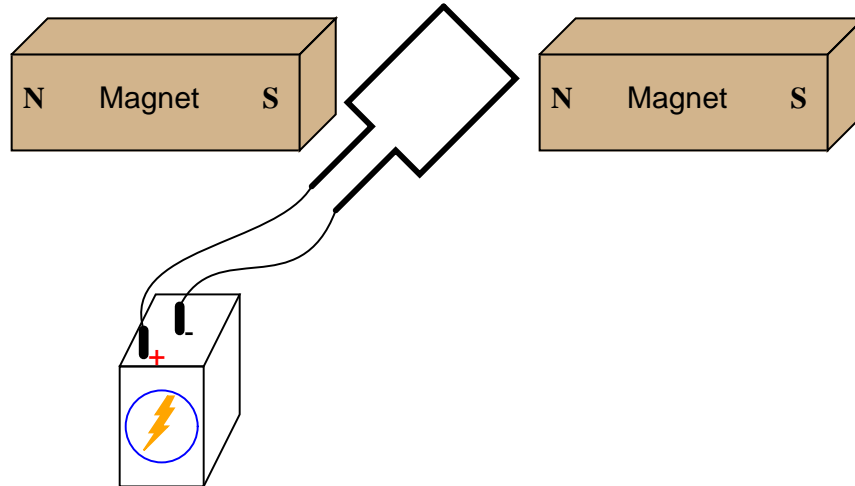

If this experiment is carried out, it may be found that the torque generated is quite small without resorting to high currents and/or strong magnetic fields. Devise a way to modify this apparatus so as to generate stronger torques using modest current levels and ordinary magnets.

[file 00261](#)

---

Answer 91

The loop will try to orient itself in a vertical plane, perpendicular to the axis of magnetic flux between the magnet poles:

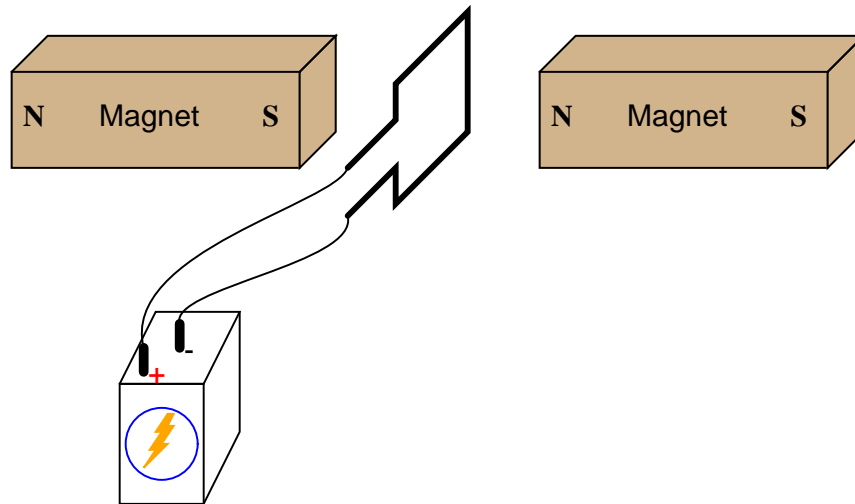

To increase the torque generated by the wire loop, you could use a loop with more than 1 "turn" of wire. This is not the only solution, though.

---

Notes 91

This question presents an excellent opportunity for discussing the "right-hand rule" (or "left-hand rule" for those using electron flow notation rather than conventional flow notation).

---

Question 92

The amount of voltage applied to a permanent-magnet DC motor, and the amount of current going through the armature windings of a permanent-magnet DC motor, are related to two mechanical quantities: maximum speed, and torque output (twisting force).

Which electrical quantity relates to which mechanical quantity? Is it voltage that relates to speed and current to torque, or visa-versa? Explain your answer.

[file 00399](#)

---

Answer 92

The amount of voltage applied to a permanent-magnet DC motor determines its no-load speed, while the amount of current through the armature windings is indicative of the torque output.

---

Notes 92

This question asks students to relate concepts of electromagnetism and electromagnetic induction together with voltage and current. While the permanent-magnet style of DC motor exhibits almost linear relationships between these variables, all DC electric motors exhibit the same general pattern: more voltage, more speed; more current, more torque; all other variables being equal.

---

Question 93

A problem has developed in this motor circuit. When the switch is turned "on", the motor does not turn. It does, however, draw a lot of current (several times the normal operating current) as indicated by the ammeter:

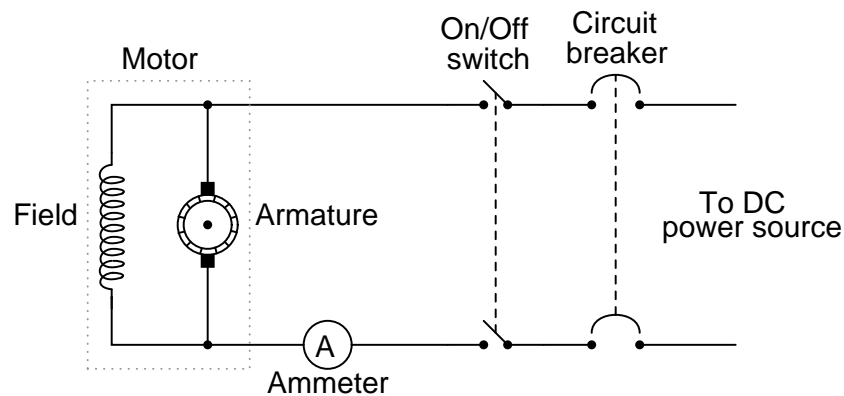

Based on this information, what do you think may be wrong with the circuit? Is there anything we know for sure is *not* failed in the circuit? Explain your answers.

[file 00400](#)

---

Answer 93

One likely cause is either the field winding or something in the armature (a brush, perhaps) failed open. Internal motor problems are not the only possibilities, however!

---

Notes 93

This question is an exercise in diagnostic thinking. Always challenge your students to try diagnosing the nature of a problem with the given information before taking further measurements or observations. Far too often people take more measurements than necessary to troubleshoot electrical systems, because they do not think carefully enough about what they are doing.

---

Question 94

What is an *electromechanical relay*?  
[file 00282](#)

---

Answer 94

An *electromechanical relay* is an electrical switch actuated by a solenoid.

---

Notes 94

If your students do not know what a "solenoid" is, this question is an excellent opportunity to find out!

---

Question 95

What will happen when the pushbutton switch is actuated in this circuit?

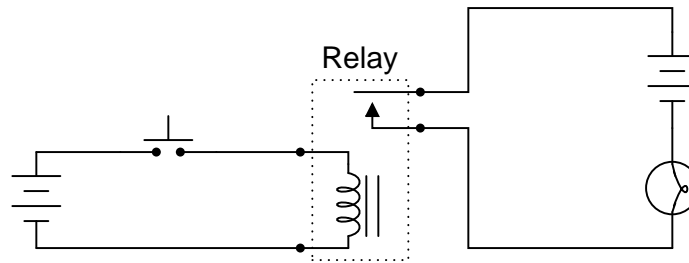

file 00283

---

Answer 95

The light bulb will energize when the pushbutton switch is actuated.

Follow-up question: is the contact inside the relay *normally-open* or is it *normally-closed*?

---

Notes 95

There is a sequence of events to the final result of the pushbutton's actuation. Be sure to ask you students to explain all the steps, from beginning to end, of this relay circuit's operation. Test their comprehension of this circuit, to ensure they fully understand what is taking place.

A logical question your students may ask is, "What is the point?" After all, a circuit with no relay at all (just a switch, battery, and lamp) could accomplish the same task! What is the point of having an extra battery and this device called a relay? Resist the temptation to tell them why, and let them figure out some possible reasons for using a relay.



---

Question 96

What will happen when the pushbutton switch is actuated in this circuit?

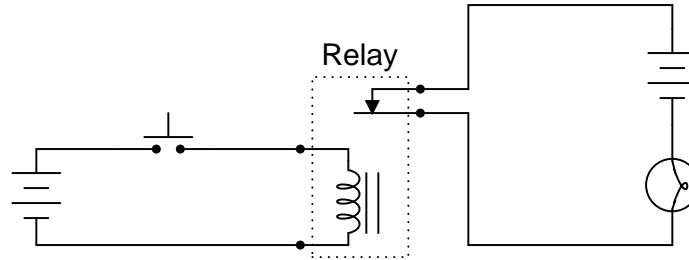

file 00284

---

Answer 96

The light bulb will de-energize when the pushbutton switch is actuated.

Follow-up question: is the contact inside the relay *normally-open* or is it *normally-closed*?

---

Notes 96

There is a sequence of events to the final result of the pushbutton's actuation. Be sure to ask you students to explain all the steps, from beginning to end, of this relay circuit's operation. Test their comprehension of this circuit, to ensure they fully understand what is taking place.

A logical question your students may ask is, "What is the point?" After all, a circuit with no relay at all (just a switch, battery, and lamp) could accomplish the same task! What is the point of having an extra battery and this device called a relay? Resist the temptation to tell them why, and let them figure out some possible reasons for using a relay.

---

Question 97

Complete the schematic diagram for a SPDT relay circuit that energizes the green light bulb (only) when the pushbutton switch is pressed, and energizes the red light bulb (only) when the pushbutton switch is released:

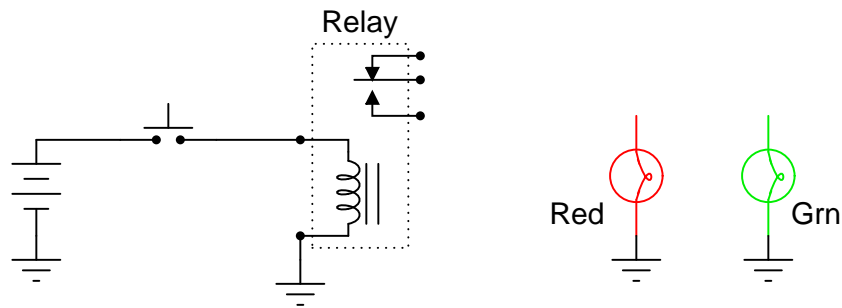

[file 00290](#)

---

Answer 97

In order for this circuit to function as specified, the green light bulb must receive power through the relay's normally-open contact, and the red light bulb through the relay's normally-closed contact.

---

Notes 97

If any students ask what "SPDT" means, refer them to a text or other information source on switch contacts in general (SPST, SPDT, DPST, DPDT, etc.).

Ground symbols were used intentionally in this question, to eliminate clutter from the diagram, and also to make students more familiar with their use as a notation for a common (reference) point in a circuit.

This question also reveals another useful feature of relays, and that is logic inversion. The green light operates in the same mode as the pushbutton switch, but the red light is opposite of the pushbutton switch. With just a single pushbutton operator, two complementary functions may be performed through the use of a SPDT relay.

---

Question 98

By moving a permanent magnet perpendicularly past a wire, a voltage will be generated between the ends of that wire:

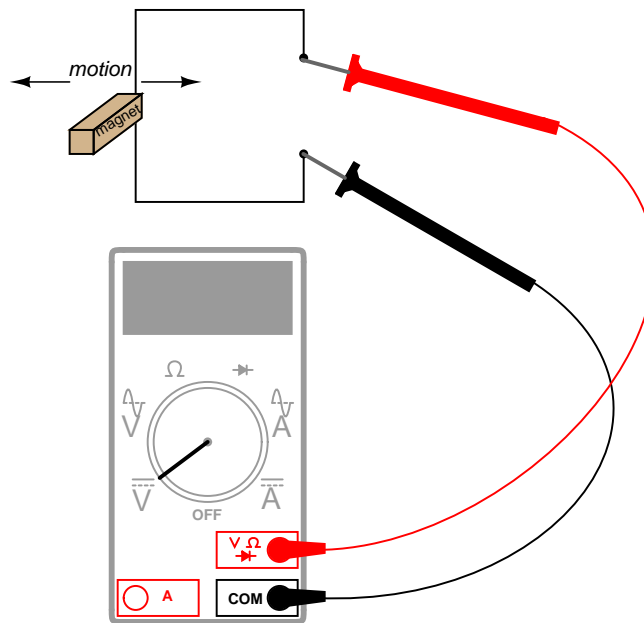

Describe what factors determine the polarity and magnitude of this voltage.  
[file 00255](#)

---

Answer 98

Rather than give the answer here, I'll leave it to you to determine the answer by experiment!

---

Notes 98

Experiments like this are so easy to set up, it would be a shame to spoil the joy of firsthand discovery by simply telling students what is supposed to happen!

---

Question 99

What will happen, electrically speaking, when the shaft of the machine is turned?

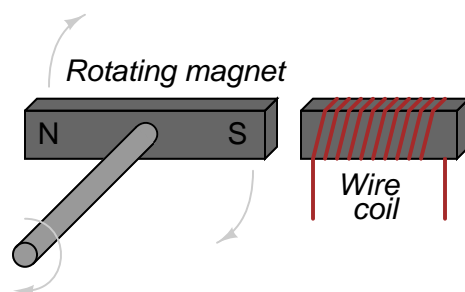

file 00227

---

Answer 99

A voltage will be "induced" in the wire coil as the magnet passes by.

Follow-up question: do you think the voltage generated by this machine would be DC or AC? Explain your answer.

---

Notes 99

Although this machine would not be very efficient in the form shown in the illustration, it would work to generate electricity when turned. As such, it demonstrates the principle of electromagnetic induction.

---

Question 100

If this wire (between the magnet poles) is moved in an upward direction, what polarity of voltage will the meter indicate?

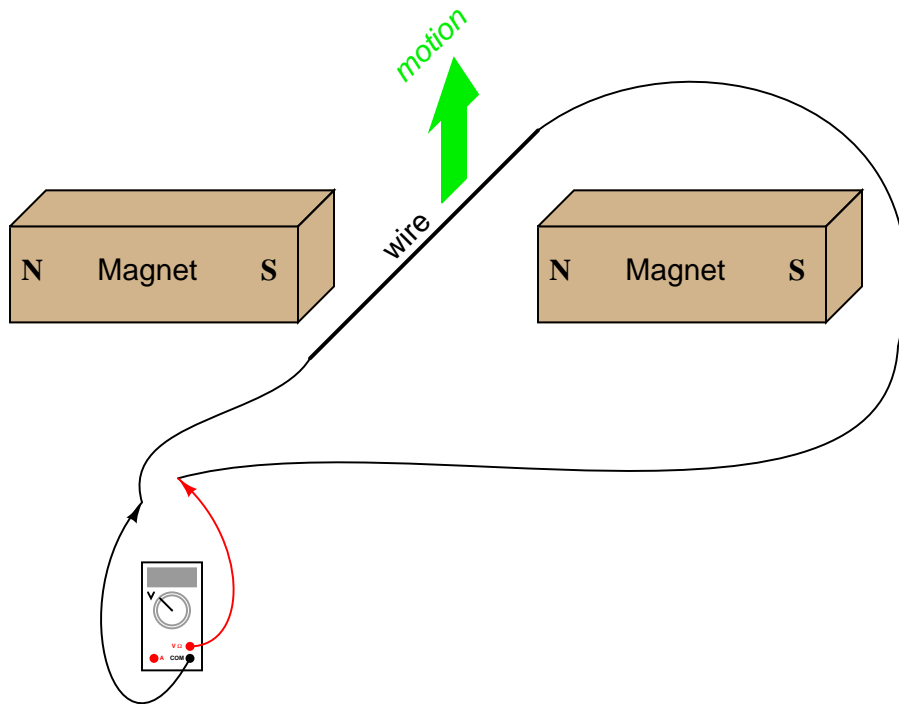

Describe the factors influencing the magnitude of the voltage induced by motion, and determine whether this is an example of an electric *motor* or an electric *generator*.

[file 00806](#)

---

Answer 100

The voltmeter will indicate a negative voltage in this *generator* example.

---

Notes 100

Ask your students to explain their answers regarding factors that influence voltage magnitude. Where did they obtain their information? Are there any mathematical formulae relating these factors to induced voltage?

---

### Question 101

If this wire (between the magnet poles) is moved in an upward direction, and the wire ends are connected to a resistive load, which way will current go through the wire?

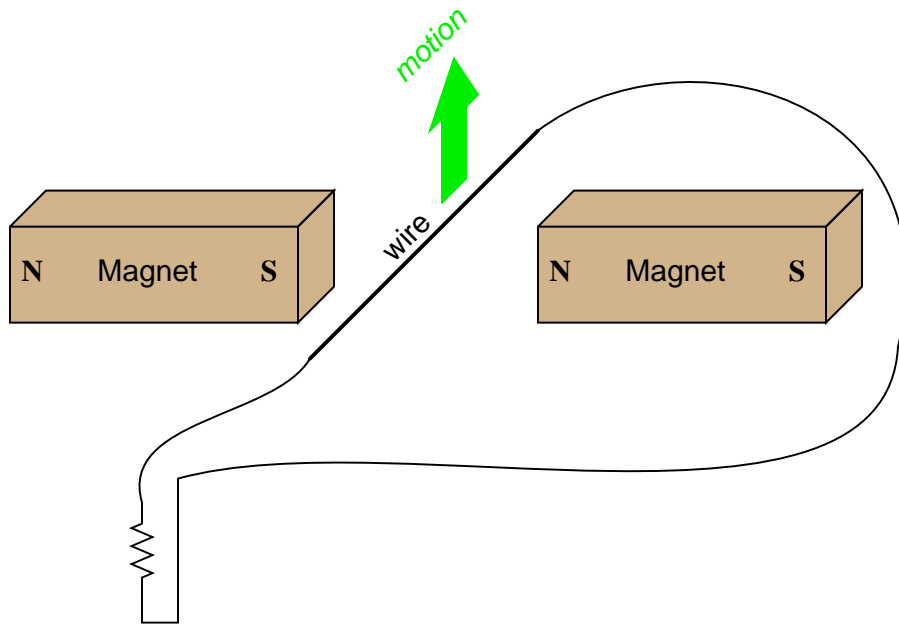

We know that current moving through a wire will create a magnetic field, and that this magnetic field will produce a reaction force against the static magnetic fields coming from the two permanent magnets. Which direction will this reaction force push the current-carrying wire? How does the direction of this force relate to the direction of the wire's motion? Does this phenomenon relate to any principle of electromagnetism you've learned so far?

[file 00807](#)

---

### Answer 101

The reaction force will be directly opposed to the direction of motion, as described by Lenz's Law.

Follow-up question: What does this phenomenon indicate to us about the ease of moving a generator mechanism under load, versus unloaded? What effect does placing an electrical load on the output terminals of a generator have on the mechanical effort needed to turn the generator?

---

### Notes 101

If you happen to have a large, permanent magnet DC motor available in your classroom, you may easily demonstrate this principle for your students. Just have them spin the shaft of the motor (generator) with their hands, with the power terminals open versus shorted together. Your students will notice a huge difference in the ease of turning between these two states.

After your students have had the opportunity to discuss this phenomenon and/or experience it themselves, ask them why electromechanical meter movement manufacturers usually ship meters with a shorting wire connecting the two meter terminals together. In what way does a PMMC meter movement resemble an electric generator? How does shorting the terminals together help to protect against damage from physical vibration during shipping?

Ask your students to describe what factors influence the magnitude of this reaction force.

Question 102

Determine the polarity of induced voltage between the ends of this wire loop, as it is rotated between the two magnets:

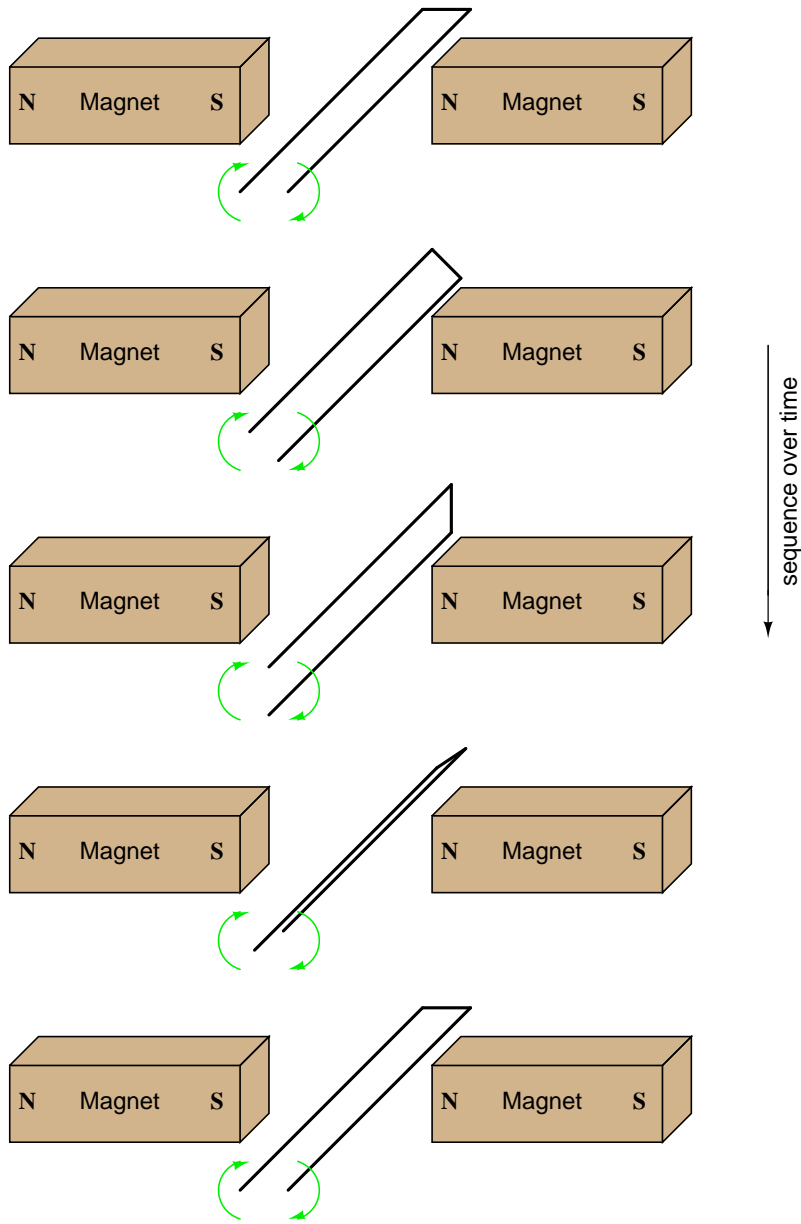

file 00808

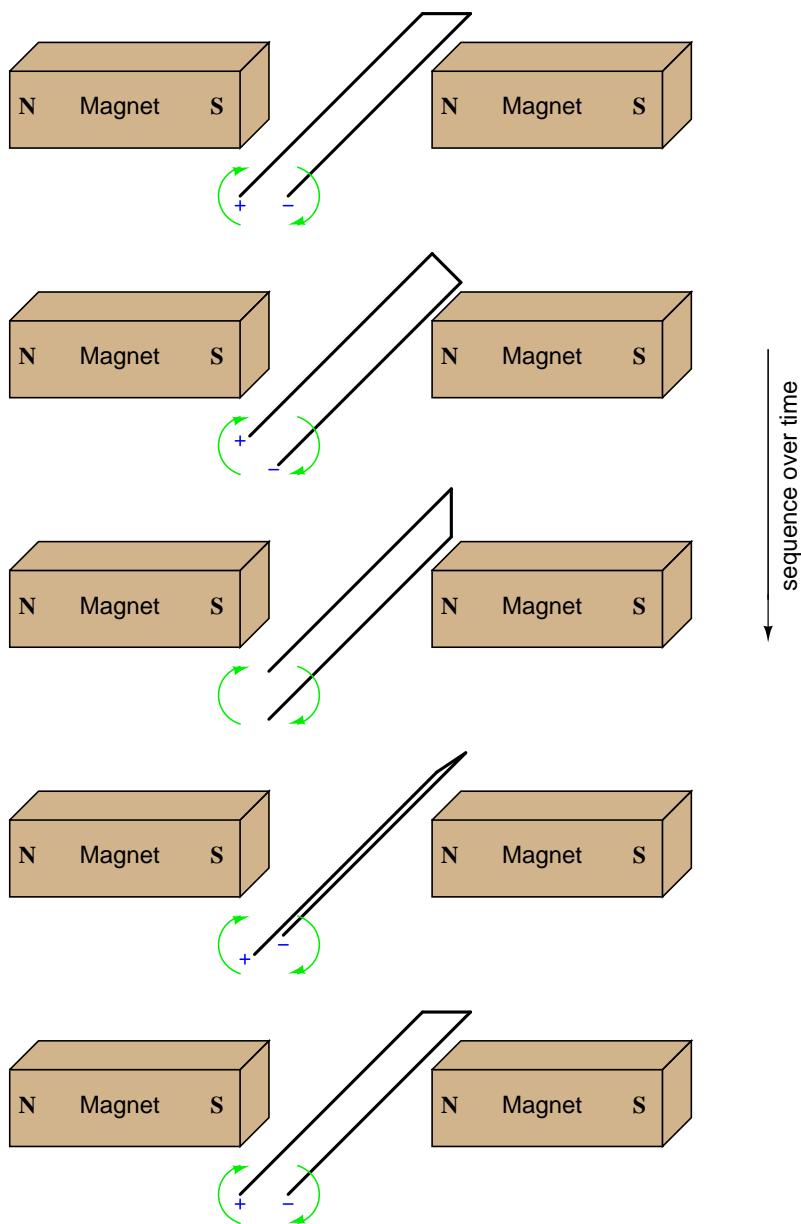

Challenge question: if a resistor were connected between the ends of this wire loop, would it "see" direct current (DC), or alternating current (AC)?

Notes 102

Note that the two wire ends switch polarity as the loop rotates. Ask your students to explain why the polarities are as they are.



---

Question 103

If the ends of a wire loop are attached to two half-circular metal strips, arranged so that the two strips almost form a complete circle, and those strips are contacted by two "brushes" which connect to opposite poles of a battery, what polarity of voltage will be measured as the loop is rotated counter-clockwise?

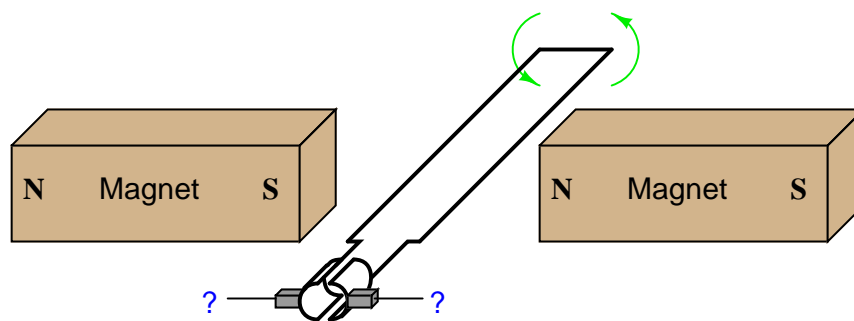

file 00809

---

Answer 103

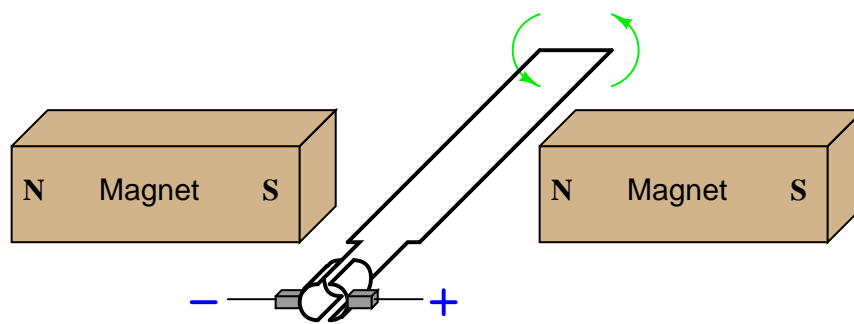

Follow-up question: does the polarity measured at the two carbon brushes ever reverse? Or, to phrase the question another way, if a resistor were connected between the two brush contacts, would it "see" direct current (DC) or alternating current (AC)? Explain your answer.

---

Notes 103

Ask your students what the two half-circle metal strips are called, in electric motor/generator terminology.

---

Question 104

Suppose there was something wrong in this electrical system. When the shaft of the generator is turned, the light bulb does not light up:

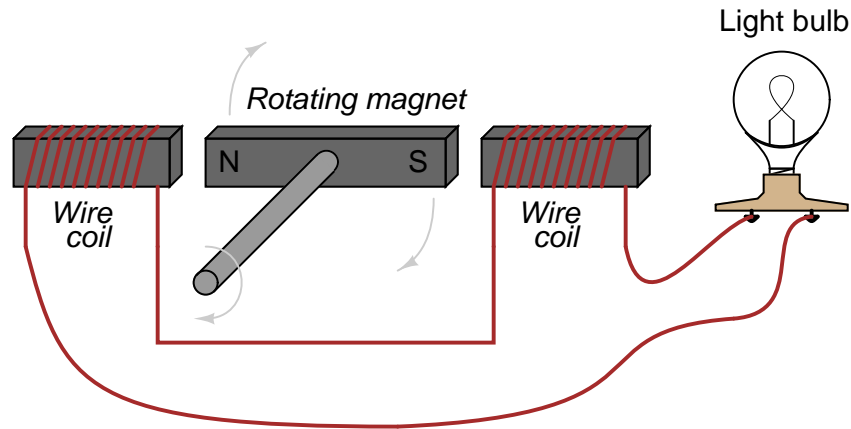

What are some of the possible causes of this failure? Please be specific. Also, what could you do to either confirm or deny these specific possibilities?

[file 00229](#)

---

Answer 104

There may be an "open" fault in the circuit somewhere, and/or the light bulb could be improperly sized for the generator's rated voltage output. I'll let you determine how certain diagnostic checks could be made in this system to determine the exact nature of the fault!

---

Notes 104

This question poses an excellent opportunity to group discussion on troubleshooting theory and technique. There are several different ways in which the nature of the fault may be determined. Encourage your students to think creatively!

---

Question 105

How does Faraday's Law of electromagnetic induction relate to the voltage output of a DC generator? According to Faraday's Law, what factors can we alter to increase the voltage output by a DC generator?  
[file 00810](#)

---

Answer 105

Increase the  $\frac{d\phi}{dt}$  rate of change, or increase the number of turns in the armature winding.

---

Notes 105

Ask your students to write the equation for Faraday's Law on the whiteboard, and then analyze it in a qualitative sense (with variables increasing or decreasing in value) to validate the answers.

The first answer to this question (increase  $\frac{d\phi}{dt}$ ) has been left purposefully vague, in order to make students think. What, specifically, must be changed in order to increase this rate-of-change over time? Which real-world variables are changeable after the generator has been manufactured, and which are not?

---

### Question 106

DC generators will act as DC motors if connected to a DC power source and not spun at a sufficient speed. This is a problem in DC power systems, as the generator will act as a load, drawing energy from the battery, when the engine or other "prime mover" device stops moving. This simple generator/battery circuit, for example, would not be practical for this reason:

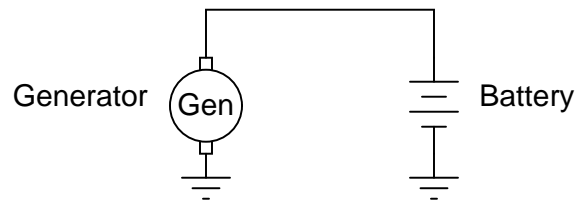

Back in the days when automobiles used DC generators to charge their batteries, a special relay called the *reverse current cutout* relay was necessary to prevent battery discharge through the generator whenever the engine was shut off:

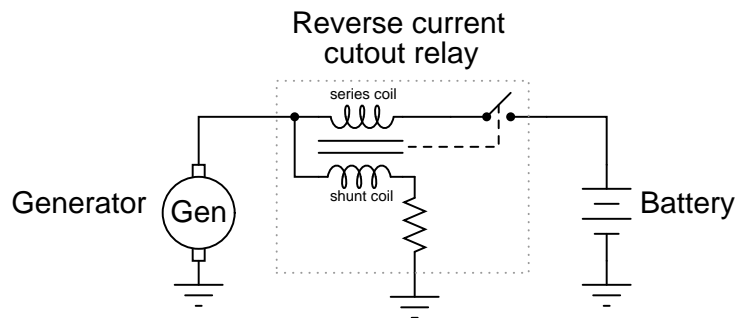

When the generator is spun fast enough, it generates enough voltage to energize the shunt coil with enough current to close the relay contact. This connects the generator with the battery, and charging current flows through the series coil, creating even more magnetic attraction to hold the relay contact closed. If the battery reaches a full charge and does not draw any more charging current from the generator, the relay will still remain closed because the shunt coil is still energized.

However, the relay contact will open if the generator ever begins to act as a load to the battery, drawing any current from it. Explain why this happens.

[file 00804](#)

---

### Answer 106

If a reverse current goes through the series coil, the magnetic field produced will "buck" the magnetic field produced by the shunt coil, thus weakening the total magnetic field strength pulling at the armature of the relay.

---

### Notes 106

A "reverse current cutout" relay ingeniously exploits reversible magnetic polarities to close or open a contact under the proper conditions. Although DC generators are no longer used in the majority of automobile electrical systems (AC alternators using bridge rectifiers to convert AC to DC are used instead, with the rectifier circuit naturally preventing reverse current), this application provides an excellent opportunity to explore an application of relay technology in the context of generator control.

---

Question 107

A *shunt-wound* generator has an electromagnet "field" winding providing the stationary magnetic field in which the armature rotates:

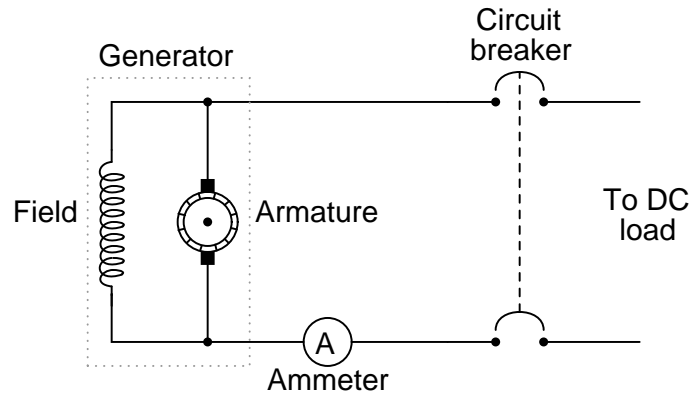

Like all electromagnets, the magnetic field strength produced is in direct proportion to the amount of current through the wire coil. But when the generator is sitting still, its output voltage is zero, and therefore there will be no current through the field winding to energize it and produce a magnetic field for the armature to rotate through. This causes a problem, since the armature will not have any voltage induced in its windings until it is rotating *and* it has a stationary magnetic field from the field winding to rotate through.

It seems like we have a catch-22 situation here: the generator cannot output a voltage until its field winding is energized, but its field winding will not be energized until the generator (armature) outputs some voltage. How can this generator ever begin to output voltage, given this predicament?

[file 00812](#)

---

Answer 107

Usually, there is enough *residual* magnetism left in the field poles to initiate some generator action when turned.

Challenge question: what we could do if the generator's field poles ever totally lost their residual magnetism? How could the generator ever be started?

---

Notes 107

Back in the days when generators were common in automotive electrical systems, this used to be a fairly common problem. However, generators could be "flashed" so as to re-establish this residual magnetic field once again.

---

Question 108

In a *shunt-wound* DC generator, the output voltage is determined by the rotational speed of the armature and the density of the stationary magnetic field flux. For a given armature speed, what prevents the output voltage from "running away" to infinite levels, since the output voltage energizes the field winding, which leads to greater field flux, which leads to greater output voltage, which leads to greater field flux, which leads to . . . ?

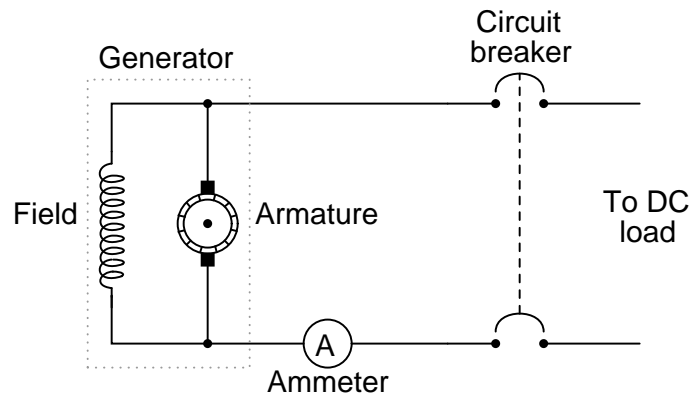

Obviously, there must be some inherent limit to this otherwise vicious cycle. Otherwise, the output voltage of a shunt-wound DC generator would be completely unstable.

[file 00814](#)

---

Answer 108

At a certain amount of field winding current, the generator's field poles *saturate*, preventing further increases in magnetic flux.

---

Notes 108

This question provides a great opportunity to review the concept of magnetic "saturation," as well as introduce the engineering concept of *positive feedback*.

---

### Question 109

Generators used in battery-charging systems must be *regulated* so as to not overcharge the battery(ies) they are connected to. Here is a crude, relay-based voltage regulator for a DC generator:

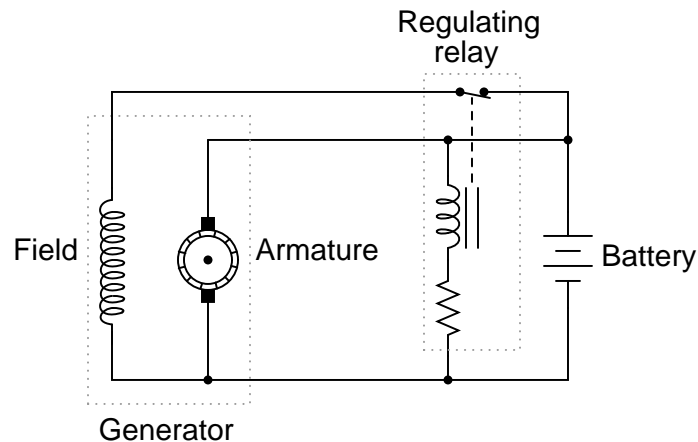

Simple electromechanical relay circuits such as this one were very common in automotive electrical systems during the 1950's, 1960's, and 1970's. The fundamental principle upon which their operation is based is called *negative feedback*: where a system takes action to *oppose* any change in a certain variable. In this case, the variable is generator output voltage. Explain how the relay works to prevent the generator from overcharging the battery with excessive voltage.

[file 01021](#)

---

### Answer 109

If the battery voltage becomes excessive, the relay opens and de-energizes the field winding. When the voltages sags back down to an acceptable level, the relay re-closes and re-energizes the field winding so that the generator can begin generating voltage again.

Challenge question: what would we have to change in this circuit to alter the generator's voltage regulation set-point (the "target" voltage at which the generator's output is supposed to be regulated)?

---

### Notes 109

The circuit drawn here is very similar to real generator regulator circuits used in American automobiles before the advent of inexpensive, reliable semiconductor circuits. I show it here not just for historical background, but also to demonstrate how relatively crude circuits are still able to perform certain tasks reasonably well.

"Negative feedback" is one of the fundamental principles of electronics and electrical engineering. A simple system like this provides a good way to gently introduce students to this vital concept.

---

Question 110

Electrically conductive materials may be rated according to their relative resistance by a quantity we call *specific resistance* ( $\rho$ ). The formula relating resistance to specific resistance looks like this:

$$R = \rho \frac{l}{A}$$

Where,

$R$  = Electrical resistance, in ohms

$\rho$  = Specific resistance, in ohm-cmil/ft, or some other combination of units

$l$  = Length of conductor, in feet or cm (depending on units for  $\rho$ )

$A$  = Cross-sectional area of conductor, in cmil or cm<sup>2</sup> (depending on units for  $\rho$ )

Magnetic materials may also be rated according to their relative reluctance by a quantity we call *permeability* ( $\mu$ ). Write the formula relating reluctance to permeability of a magnetic substance, and note whatever differences and similarities you see between it and the specific resistance formula for electrical circuits.

file 00680

---

Answer 110

$$\mathfrak{R} = \frac{l}{\mu A}$$

---

Notes 110

Ask your students to describe the effects on magnetic reluctance resulting from increases and decreases in all three independent variables ( $\mu$ ,  $l$ , and  $A$ ). It is important for them to qualitatively grasp this equation, just as it is important for them to qualitatively understand Ohm's Law and the specific resistance formula.



---

Question 111

Explain the difference between relative permeability ( $\mu_r$ ) and absolute permeability ( $\mu$ ). How do the units of measurement differ between these two quantities?

[file 00684](#)

---

Answer 111

$$\mu_r = \frac{\mu}{\mu_0}$$

Absolute permeability is measured in units of Webers per Amp-meter (Wb/Am), while relative permeability has no unit at all.

---

Notes 111

Ask your students to explain *why* relative permeability ( $\mu_r$ ) is unitless. Are there any other variables they've encountered in their science studies that are similarly unitless?

Did any of your students research the value of absolute permeability of free space ( $\mu_0$ )? If so, what figure did they obtain?

---

Question 112

Using a B-H curve obtained from a reference book, determine the amount of magnetizing force ( $H$ ) required to establish a magnetic flux density of 0.2 T in a cast iron torus with a cross-sectional area of  $7 \times 10^{-4}$  square meters.

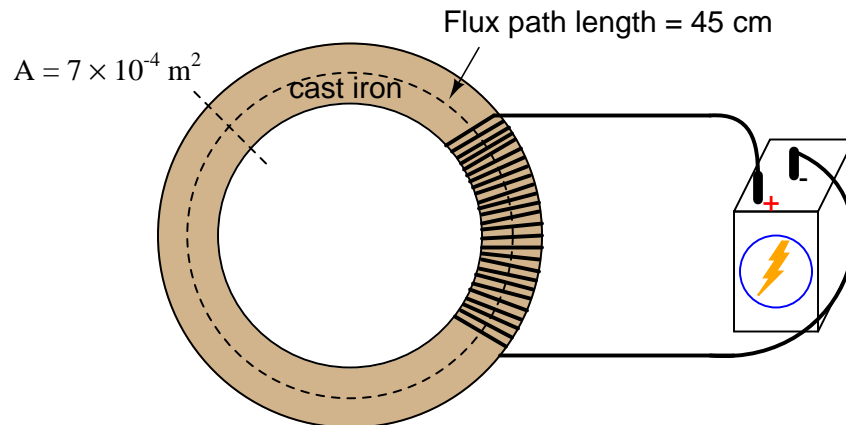

Calculate the amount of current necessary in the wire coil to establish this amount of flux, if the coil has 250 turns, and the torus has an average flux path length of 45 cm. Also, calculate the amount of magnetic flux ( $\Phi$ ) inside the torus.

[file 00686](#)

---

Answer 112

$$H = 400 \text{ At/m}$$

$$I = 720 \text{ mA}$$

$$\Phi = 0.14 \text{ mWb}$$

---

Notes 112

I obtained the magnetizing force figure of 400 At/m for 0.2 T of flux density, from Robert L. Boylestad's 9th edition of [Introductory Circuit Analysis](#), page 437.

---

Question 113

If a wire coil with 320 turns is exposed to a magnetic flux decreasing at a rate of 0.03 Webers per second (as shown in the illustration), how much voltage will be induced across the coil, and what will its polarity be?

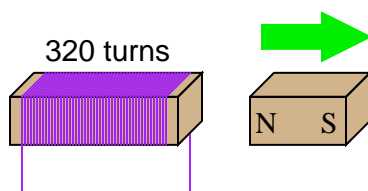

file 03272

---

Answer 113

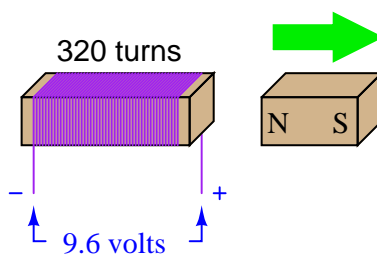

---

Notes 113

This question is both a quantitative application of Faraday's Law and an application of Lenz's Law.

---

Question 114

If a wire coil with 1100 turns is exposed to a magnetic flux increasing at a rate of 0.07 Webers per second (as shown in the illustration), how much voltage will be induced across the coil, and what will its polarity be?

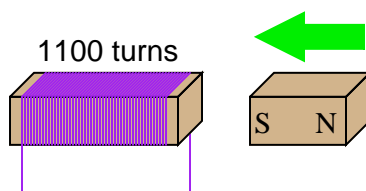

file 03273

---

Answer 114

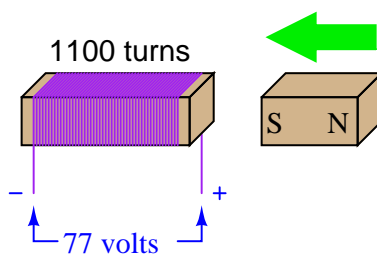

---

Notes 114

This question is both a quantitative application of Faraday's Law and an application of Lenz's Law.

---

Question 115

Calculate the necessary magnetic flux rate-of-change over time (in units of Webers per second) as well as the direction of magnet motion (either toward or away from the coil) to induce a voltage of 13.5 volts in the polarity shown:

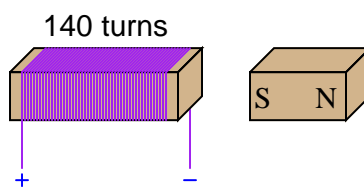

[file 03274](#)

---

Answer 115

$\frac{d\phi}{dt}$  must be equal to 0.0964 Webers per second, with the magnet moving away from the coil.

---

Notes 115

This question is both a quantitative application of Faraday's Law and an application of Lenz's Law.

---

### Question 116

Give a step-by-step procedure for "Thévenizing" *any* circuit: finding the Thévenin equivalent voltage ( $V_{Thevenin}$ ) and Thévenin equivalent resistance ( $R_{Thevenin}$ ).

- Step #1:
- Step #2:

[file 02456](#)

---

### Answer 116

This is easy enough for you to look up in any electronics textbook. I'll leave you to it!

Follow-up question: describe the difference in how one must consider *voltage sources* versus *current sources* when calculating the equivalent circuit's resistance ( $R_{Thevenin}$ ) of a complex circuit containing both types of sources?

---

### Notes 116

I really mean what I say here about looking this up in a textbook. Thévenin's Theorem is a very well-covered subject in many books, and so it is perfectly reasonable to expect students will do this research on their own and come back to class with a complete answer.

The follow-up question is very important, because some circuits (especially transistor amplifier circuits) contain *both* types of sources. Knowing how to consider each one in the process of calculating the Thévenin equivalent resistance for a circuit is very important. When performing this analysis on transistor amplifiers, the circuit often becomes much simpler than its original form with all the voltage sources shorted and current sources opened!

---

### Question 117

Give a step-by-step procedure for "Nortonizing" *any* circuit: finding the Norton equivalent current ( $V_{Norton}$ ) and Norton equivalent resistance ( $R_{Norton}$ ).

- Step #1:
- Step #2:

[file 03229](#)

---

### Answer 117

This is easy enough for you to look up in any electronics textbook. I'll leave you to it!

Follow-up question: describe the difference in how one must consider *voltage sources* versus *current sources* when calculating the equivalent circuit's resistance ( $R_{Norton}$ ) of a complex circuit containing both types of sources?

---

### Notes 117

I really mean what I say here about looking this up in a textbook. Norton's Theorem is a very well-covered subject in many books, and so it is perfectly reasonable to expect students will do this research on their own and come back to class with a complete answer.

The follow-up question is very important, because some circuits (especially transistor amplifier circuits) contain *both* types of sources. Knowing how to consider each one in the process of calculating the Norton equivalent resistance for a circuit is very important. When performing this analysis on transistor amplifiers, the circuit often becomes much simpler than its original form with all the voltage sources shorted and current sources opened!

---

Question 118

What would happen if a wire having no resistance at all ( $0 \Omega$ ) were connected directly across the terminals of a 6-volt battery? How much current would result, according to Ohm's Law?

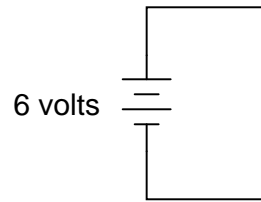

Suppose we were to short-circuit a 6-volt battery in the manner just described and measure 8 amps of current. Why don't the calculated figures from the previous paragraph agree with the actual measurement?  
[file 00106](#)

---

Answer 118

Ohm's Law would suggest an infinite current (current = voltage divided by zero resistance). Yet, the experiment described yields only a modest amount of current.

If you think that the wire used in the experiment is not resistance-less (i.e. it *does* have resistance), and that this accounts for the disparity between the predicted and measured amounts of current, you are partially correct. Realistically, a small piece of wire such as that used in the experiment will have a few tenths of an ohm of resistance. However, if you re-calculate current with a wire resistance of  $0.1 \Omega$ , you will still find a large disparity between your prediction and the actual measured current in this short-circuit.

Follow-up question #1: explain why wire resistance alone does not explain the modest short-circuit current.

Follow-up question #2: identify at least one safety hazard associated with a real experiment such as this.

---

Notes 118

Remind students that short-circuit testing of electrical power sources can be dangerous. A student of mine once stuffed a 6-volt "lantern" battery in his tool pouch, only to have it discharge smoke an hour later, after the battery terminals had been shorted together by a wrench handle!

No, Ohm's Law is not being cheated here: shorting a voltage source with a  $0 \Omega$  conductor will not result in infinite current, because there are *other* sources of resistance in such a circuit. The task here is to determine where those sources might be, and how they could be located.



---

Question 119

A practical *current source* may be built using a battery and a special semiconductor component known as a *current-limiting diode*:

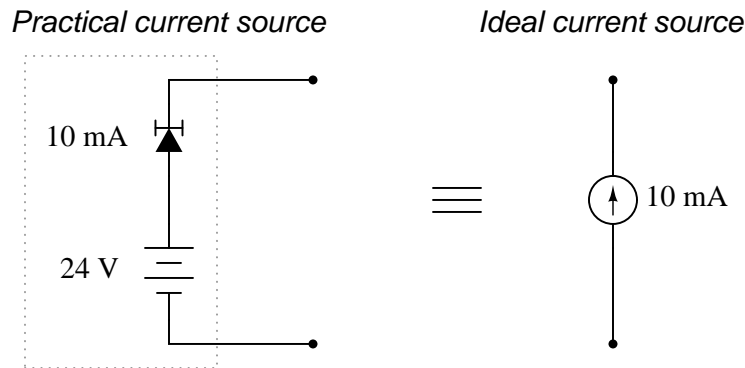

The current-limiting diode acts as a variable resistance, to regulate current through it at a constant value: if current increases, its resistance increases to reduce the current back to where it should be; if current decreases, its resistance decreases to increase current up to where it should be.

Determine the amount of voltage output by an open-circuited (ideal) current source. Contrast this with the voltage output by the practical current source shown in the diagram. Finally, draw an equivalent circuit showing an ideal current source somehow connected to a resistance in such a way that its open-circuited output voltage is identical to the practical current source.

[file 01035](#)

---

Answer 119

An ideal current source outputs infinite voltage when open-circuited. The practical current source shown in the diagram outputs 24 volts.

Equivalent circuit:

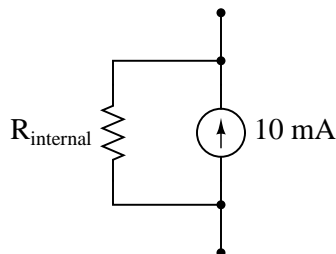

Follow-up question: the more "ideal" a current source is, the (*choose one: greater, or less*) its internal resistance will be. Compare this with the internal resistance of an ideal voltage source.

---

Notes 119

A point of difficulty with some students is the word *infinite*. I have found it surprisingly common for students to confuse the concept "infinite" with the concept "infinitesimal". If any of your students are confused in the same manner, it will become evident when they try to explain the open-circuit output voltage of an ideal current source.

Question 120

An *electric arc welder* is a low-voltage, high-current power source designed to supply enough electric current to sustain an arc capable of welding metal with its high temperature:

Electric "arc" welding

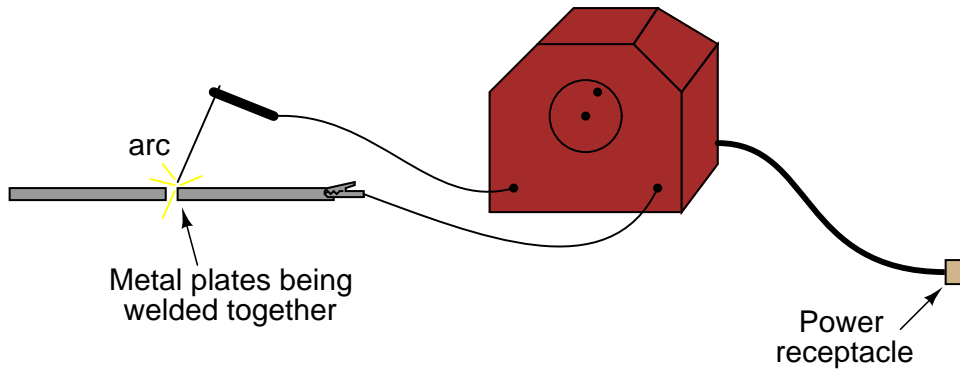

It is possible to derive a Norton equivalent circuit for an arc welder based on empirical measurements of voltage and current. Take for example these measurements, under *loaded* and *no-load* conditions:

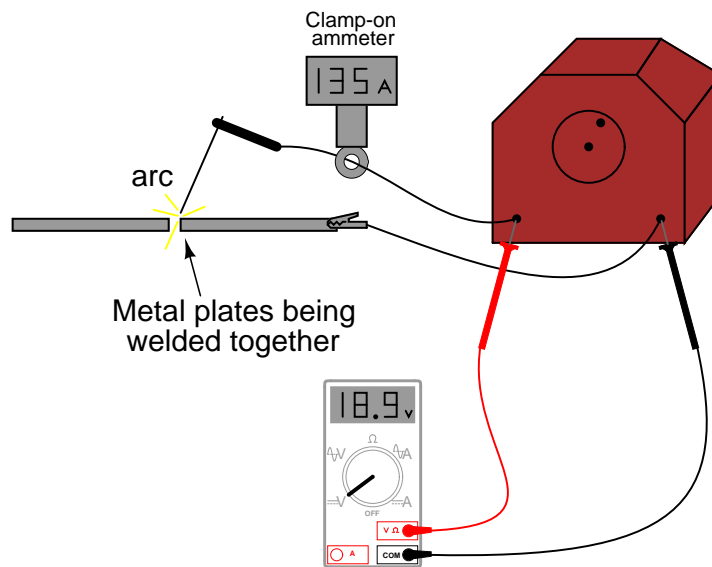

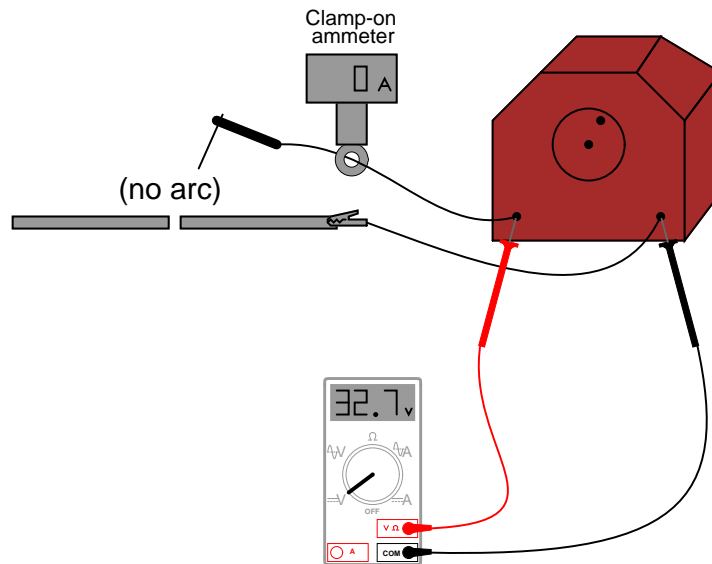

Based on these measurements, draw a Norton equivalent circuit for the arc welder.  
[file 03292](#)

Answer 120

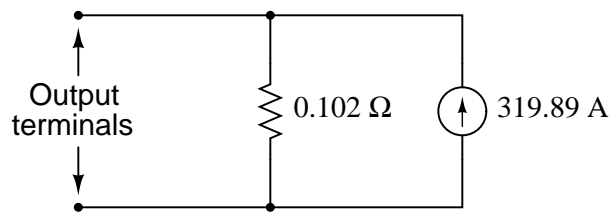

Notes 120

This practical scenario shows how Norton's theorem may be used to "model" a complex device as two simple components (current source and resistor). Of course, we must make certain assumptions when modeling in this fashion: we assume, for instance, that the arc welder is a linear device, which may or may not be true.

Incidentally, there is such a thing as a DC-measuring clamp-on ammeter as shown in the illustrations, in case any one of your students ask. AC clamp-on meters are simpler, cheaper, and thus more popularly known, but devices using the Hall effect are capable of inferring DC current by the strength of an unchanging magnetic field, and these Hall-effect devices are available at modest expense.

---

Question 121

Observe the following circuit:

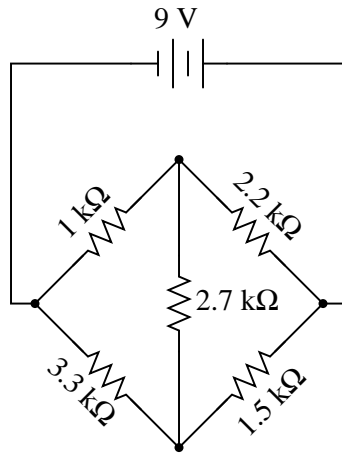

Note that it is not reducible to a single resistance and power source. In other words, it is *not* a series-parallel combination circuit. And, while it is a bridge circuit, you are not able to simply analyze the resistor ratios because it is obviously not in a state of balance!

If you were asked to calculate voltage or current for any component in this circuit, it would be a difficult task . . . unless you know either Thévenin's or Norton's theorems, that is!

Apply either one of these theorems to the determination of voltage across the 2.2 kΩ resistor (the resistor in the upper-right corner of the bridge). Hint: consider the 2.2 kΩ resistor as the *load* in a Thévenin or Norton equivalent circuit.

[file 02025](#)

---

Answer 121

$$V_{2.2k\Omega} = 5.6624 \text{ volts}$$

Hint: the Thévenin equivalent circuit looks like this (with the 2.2 kΩ resistor connected as the load):

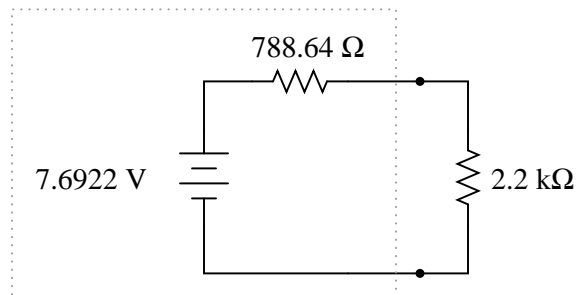

---

Notes 121

Both Thévenin's and Norton's theorems are powerful circuit analysis tools, if you know how to apply them! Students often have difficulty seeing how to analyze the bridge circuit (with the "load" resistor removed), using series-parallel and redrawing techniques. Be prepared to help them through this step during discussion time.

---

Question 122

An ideal (perfect) current source is an abstraction with no accurate realization in life. However, we may approximate the behavior of an ideal current source with a high-voltage source and large series resistance:

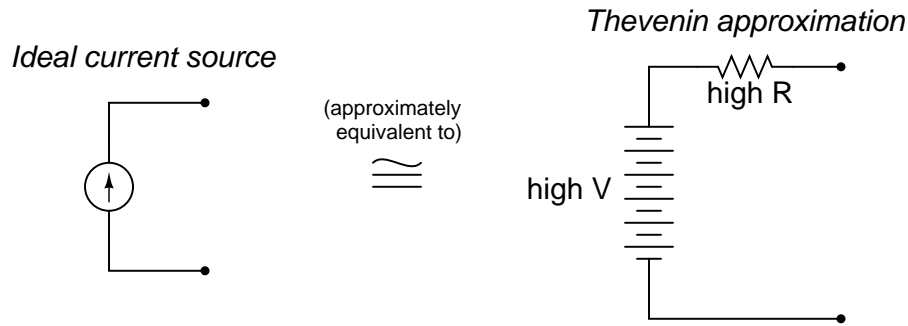

Such a Thevenin equivalent circuit, however imperfect, will maintain a fairly constant current through a wide range of load resistance values.

Similarly, an ideal (perfect) voltage source is an abstraction with no accurate realization in life. Thankfully, though, it is not difficult to build voltage sources that are relatively close to perfect: circuits with very low internal resistance such that the output voltage sags only a little under high-current conditions.

But suppose we lived in a world where things were the opposite: where close-to-ideal *current* sources were simpler and more plentiful than close-to-ideal voltage sources. Draw a Norton equivalent circuit showing how to approximate an ideal voltage source using an ideal (perfect) current source and a shunt resistance.

[file 03293](#)

---

Answer 122

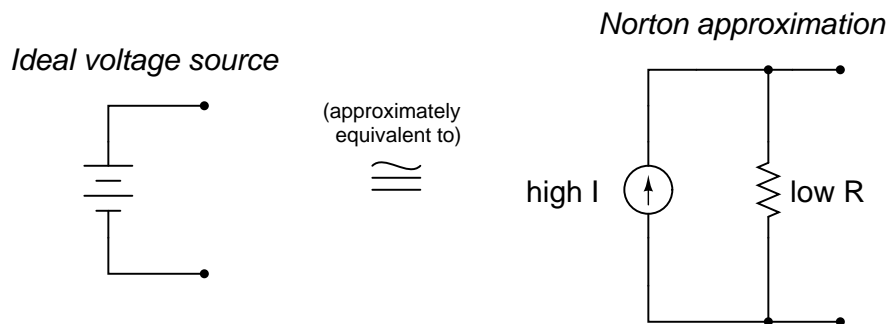

---

Notes 122

This question is not so much a practical one as it is designed to get students to think a little deeper about the differences between ideal voltage and current sources. In other words, it focuses on concepts rather than application.

---

Question 123

A large industrial electric motor is supplied power through a pair of fuses:

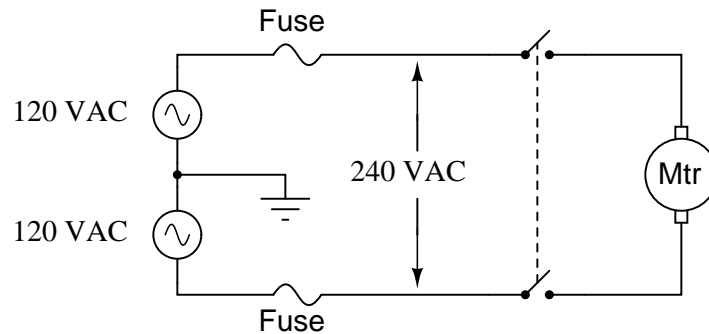

One day the motor suddenly stops running, even though the switch is still in the "on" position. An electrician is summoned to troubleshoot the failed motor, and this person decides to perform some voltage measurements to determine whether or not one of the fuses has "blown" open before doing anything else. The measurements taken by the electrician are as such (with the switch in the "on" position):

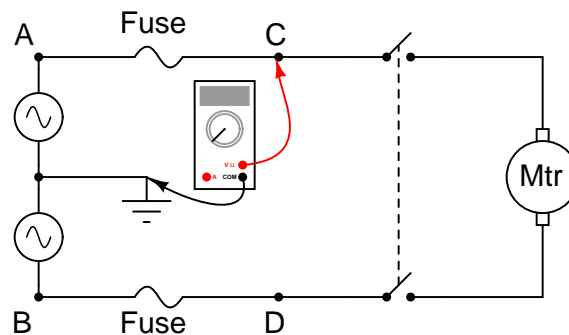

- Between A and ground = 120 volts AC
- Between B and ground = 120 volts AC
- Between C and ground = 120 volts AC
- Between D and ground = 120 volts AC

Based on these measurements, the electrician decides that both fuses are still in good condition, and that the problem lies elsewhere in the circuit. Do you agree with this assessment? Why or why not?

[file 00330](#)

---

Answer 123

So long as the switch is still in the "on" position when these measurements were taken, one of the fuses could still be blown!

Follow-up question: what voltage measurement(s) would conclusively test the condition of both fuses?

---

Notes 123

I have actually seen an experienced electrician make this mistake on the job! Ask your students to explain how full voltage could be measured at points C and D, with respect to ground, even with one of the fuses blown.

---

Question 124

One of the resistors in this voltage divider circuit has failed (either open or shorted). Based on the voltage readings shown at each load, comparing what each load voltage is versus what it should be, determine which resistor has failed and what type of failure it is:

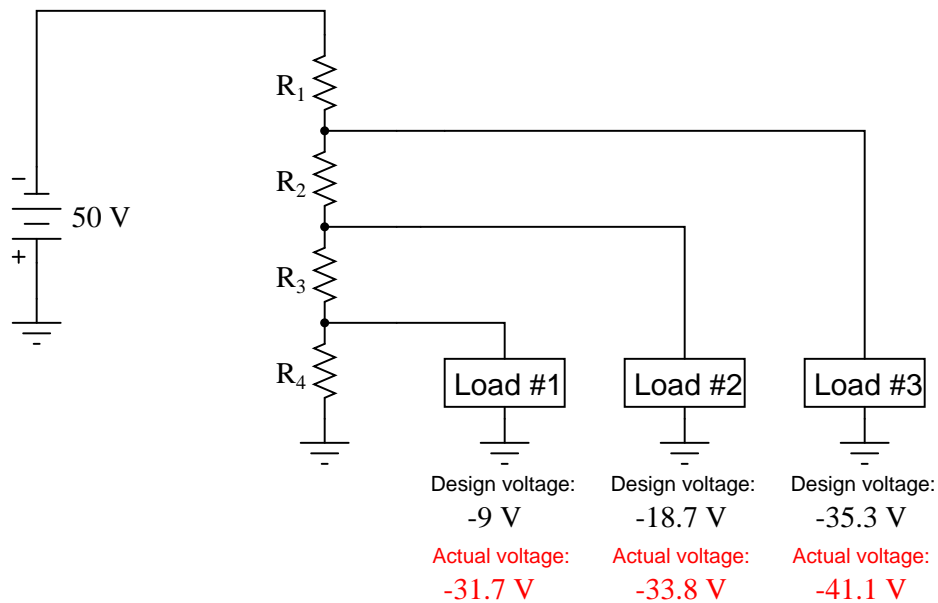

[file 03382](#)

---

Answer 124

Resistor  $R_4$  has failed open.

---

Notes 124

Use this question as an opportunity to discuss troubleshooting strategies with your students. A helpful hint in dealing with this kind of problem is to categorize each load voltage as either being *greater* or *less* than normal. Forget the negative signs here: we're dealing strictly with absolute values (in other words, -25 volts is a "greater" voltage than -20 volts). Once each load voltage has been categorized thusly, it is possible to isolate the location and nature of the fault without having to deal with numbers at all!

---

Question 125

One of the resistors in this voltage divider circuit has failed (either open or shorted). Based on the voltage readings shown at each load, comparing what each load voltage is versus what it should be, determine which resistor has failed and what type of failure it is:

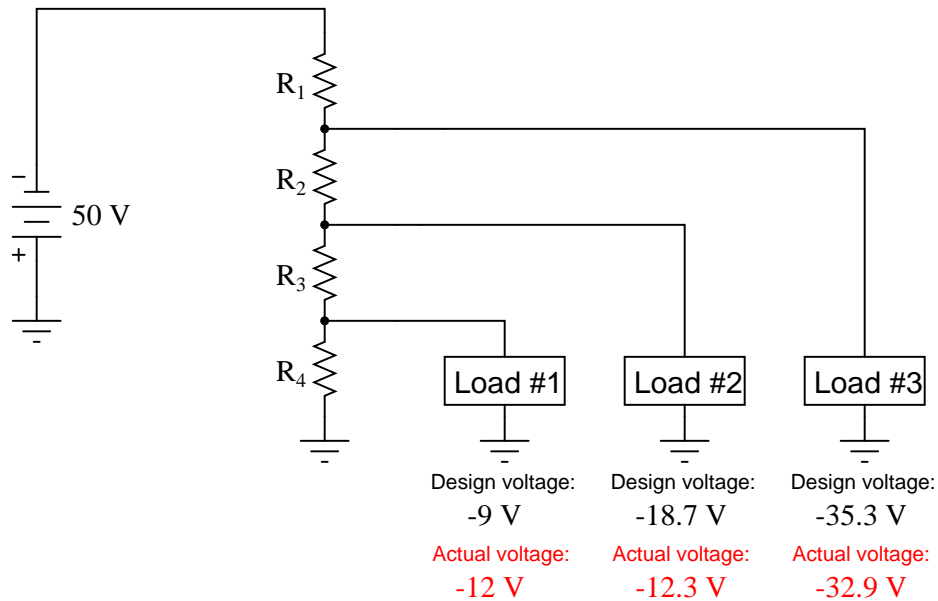

[file 03385](#)

---

Answer 125

Resistor  $R_3$  has failed shorted.

---

Notes 125

Use this question as an opportunity to discuss troubleshooting strategies with your students. A helpful hint in dealing with this kind of problem is to categorize each load voltage as either being *greater* or *less* than normal. Forget the negative signs here: we're dealing strictly with absolute values (in other words, -25 volts is a "greater" voltage than -20 volts). Once each load voltage has been categorized thusly, it is possible to isolate the location and nature of the fault without having to deal with numbers at all!



---

Question 126

One of the resistors in this voltage divider circuit has failed (either open or shorted). Based on the voltage readings shown at each load, comparing what each load voltage is versus what it should be, determine which resistor has failed and what type of failure it is:

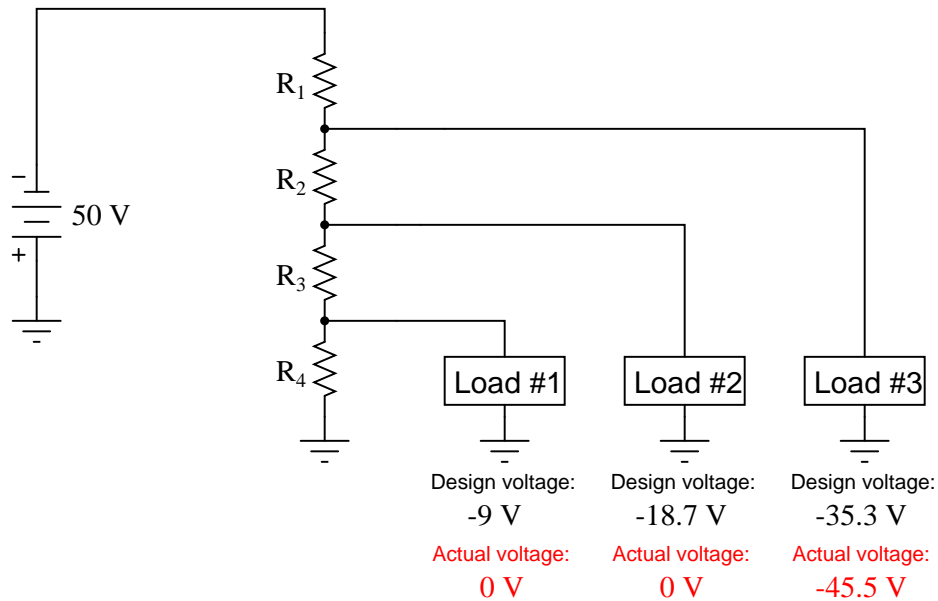

[file 03383](#)

---

Answer 126

Resistor  $R_2$  has failed open.

---

Notes 126

Use this question as an opportunity to discuss troubleshooting strategies with your students. A helpful hint in dealing with this kind of problem is to categorize each load voltage as either being *greater* or *less* than normal. Forget the negative signs here: we're dealing strictly with absolute values (in other words, -25 volts is a "greater" voltage than -20 volts). Once each load voltage has been categorized thusly, it is possible to isolate the location and nature of the fault without having to deal with numbers at all!

---

Question 127

One of the resistors in this voltage divider circuit has failed (either open or shorted). Based on the voltage readings shown at each load, comparing what each load voltage is versus what it should be, determine which resistor has failed and what type of failure it is:

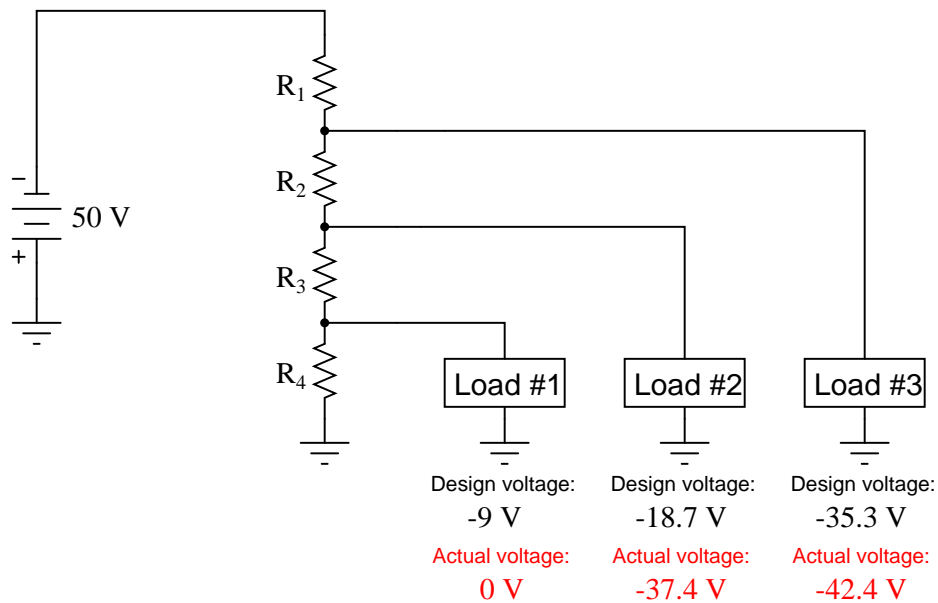

[file 03384](#)

---

Answer 127

Resistor  $R_3$  has failed open.

---

Notes 127

Use this question as an opportunity to discuss troubleshooting strategies with your students. A helpful hint in dealing with this kind of problem is to categorize each load voltage as either being *greater* or *less* than normal. Forget the negative signs here: we're dealing strictly with absolute values (in other words, -25 volts is a "greater" voltage than -20 volts). Once each load voltage has been categorized thusly, it is possible to isolate the location and nature of the fault without having to deal with numbers at all!