

Recommended schedule

Day 1

Topics: *Boolean algebra, basic concepts and identities*
Questions: *1 through 20*
Lab Exercise: *work on project*

Day 2

Topics: *Boolean algebra, simplification laws*
Questions: *21 through 40*
Lab Exercise: *Gate circuit from Boolean expression (question 96)*

Day 3

Topics: *SOP and POS expressions*
Questions: *41 through 60*
Lab Exercise: *Gate circuit from truth table (question 97)*

Day 4

Topics: *Karnaugh mapping*
Questions: *61 through 75*
Lab Exercise: *work on project*

Day 5

Topics: *DeMorgan's Theorem and gate universality*
Questions: *76 through 95*
Lab Exercise: *NAND gate universality (question 98)*

Day 6

Exam 2: *includes Boolean-to-gate performance assessment*

Troubleshooting practice problems

Questions: *100 through 109*

General concept practice and challenge problems

Questions: *110 through the end of the worksheet*

Impending deadlines

Project due at end of ELTR140, Section 3
Question 99: Sample project grading criteria

Skill standards addressed by this course section

EIA Raising the Standard; Electronics Technician Skills for Today and Tomorrow, June 1994

F Technical Skills – Digital Circuits

- F.02** Demonstrate an understanding of minimizing logic circuits using Boolean operations.
- F.08** Understand principles and operations of combinational logic circuits.
- F.09** Fabricate and demonstrate combinational logic circuits.
- F.10** Troubleshoot and repair combinational logic circuits.

B Basic and Practical Skills – Communicating on the Job

- B.01** Use effective written and other communication skills. *Met by group discussion and completion of labwork.*
- B.03** Employ appropriate skills for gathering and retaining information. *Met by research and preparation prior to group discussion.*
- B.04** Interpret written, graphic, and oral instructions. *Met by completion of labwork.*
- B.06** Use language appropriate to the situation. *Met by group discussion and in explaining completed labwork.*
- B.07** Participate in meetings in a positive and constructive manner. *Met by group discussion.*
- B.08** Use job-related terminology. *Met by group discussion and in explaining completed labwork.*
- B.10** Document work projects, procedures, tests, and equipment failures. *Met by project construction and/or troubleshooting assessments.*

C Basic and Practical Skills – Solving Problems and Critical Thinking

- C.01** Identify the problem. *Met by research and preparation prior to group discussion.*
- C.03** Identify available solutions and their impact including evaluating credibility of information, and locating information. *Met by research and preparation prior to group discussion.*
- C.07** Organize personal workloads. *Met by daily labwork, preparatory research, and project management.*
- C.08** Participate in brainstorming sessions to generate new ideas and solve problems. *Met by group discussion.*

D Basic and Practical Skills – Reading

- D.01** Read and apply various sources of technical information (e.g. manufacturer literature, codes, and regulations). *Met by research and preparation prior to group discussion.*

E Basic and Practical Skills – Proficiency in Mathematics

- E.01** Determine if a solution is reasonable.
- E.02** Demonstrate ability to use a simple electronic calculator.
- E.06** Translate written and/or verbal statements into mathematical expressions.
- E.12** Interpret and use tables, charts, maps, and/or graphs.
- E.13** Identify patterns, note trends, and/or draw conclusions from tables, charts, maps, and/or graphs.
- E.15** Simplify and solve algebraic expressions and formulas.
- E.16** Select and use formulas appropriately.
- E.18** Use properties of exponents and logarithms.
- E.21** Use Boolean algebra to break down logic circuits.

Common areas of confusion for students

Difficult concept: *Boolean rules and identities.*

In many ways Boolean algebra is simpler than regular algebra (e.g., there is no such thing as subtraction or division to worry about), but it is still algebra, and because of this fact many students struggle with it. Working with algebraic expressions means precisely following a specific set of absolute rules. This requires a reliable knowledge of those rules and an ability to think rigorously. These are not easy requirements for most human beings, which is why so many people dislike mathematics. There is but one solution to this problem: practice, practice, and practice again. If you find yourself making algebraic mistakes, don't give up – that would be exactly the wrong thing to do. Learn from your mistakes, pick yourself back up, and try again. It *can* be done!

Difficult concept: *Algebraic substitution.*

Many Boolean rules such as $A + AB = A$ are easy enough to learn in their canonical form, but more difficult to apply when seen in a form such as $CF\overline{G} + C\overline{G} = C\overline{G}$. Fundamentally, this is a problem with the algebraic principle of *substitution*: replacing one variable with a different variable or a whole expression. The key to substitution is the ability to perform visual pattern-matching, which some people have a much easier time with than others. Once again, the only solution to this problem is practice, practice, and more practice. Remember that no one comes out of the womb knowing how to do this stuff! Everyone who has any knowledge of algebra at all once started knowing nothing about it. People *can* learn and succeed at this material, yourself included. Your personal journey through algebra may be more difficult than it is for others, for any number of reasons, but it is not an impossible journey.

Questions

Question 1

Identify each of these logic gates by name, and complete their respective truth tables:

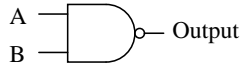

A	B	Output
0	0	
0	1	
1	0	
1	1	

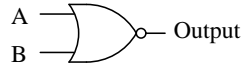

A	B	Output
0	0	
0	1	
1	0	
1	1	

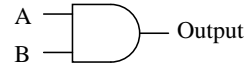

A	B	Output
0	0	
0	1	
1	0	
1	1	

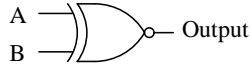

A	B	Output
0	0	
0	1	
1	0	
1	1	

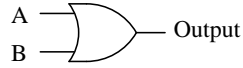

A	B	Output
0	0	
0	1	
1	0	
1	1	

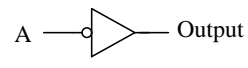

A	Output
0	
1	

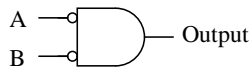

A	B	Output
0	0	
0	1	
1	0	
1	1	

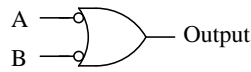

A	B	Output
0	0	
0	1	
1	0	
1	1	

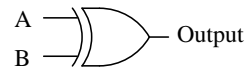

A	B	Output
0	0	
0	1	
1	0	
1	1	

file 02776

Question 2

Identify each of these relay logic functions by name (AND, OR, NOR, etc.) and complete their respective truth tables:

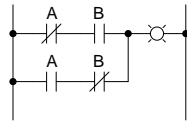

A	B	Output
0	0	
0	1	
1	0	
1	1	

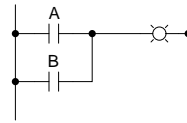

A	B	Output
0	0	
0	1	
1	0	
1	1	

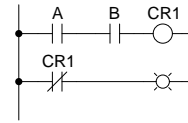

A	B	Output
0	0	
0	1	
1	0	
1	1	

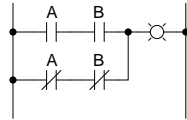

A	B	Output
0	0	
0	1	
1	0	
1	1	

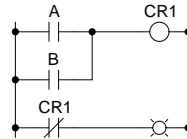

A	B	Output
0	0	
0	1	
1	0	
1	1	

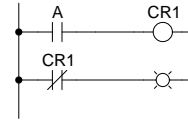

A	Output
0	
1	

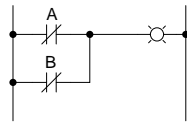

A	B	Output
0	0	
0	1	
1	0	
1	1	

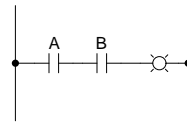

A	B	Output
0	0	
0	1	
1	0	
1	1	

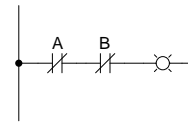

A	B	Output
0	0	
0	1	
1	0	
1	1	

file 02780

Question 3

The following set of mathematical expressions is the *complete* set of "times tables" for the Boolean number system:

$$0 \times 0 = 0$$

$$0 \times 1 = 0$$

$$1 \times 0 = 0$$

$$1 \times 1 = 1$$

Now, nothing seems unusual at first about this table of expressions, since they appear to be the same as multiplication understood in our normal, everyday system of numbers. However, what is unusual is that these four statements comprise the entire set of rules for Boolean multiplication!

Explain how this can be so, being that there is no statement saying $1 \times 2 = 2$ or $2 \times 3 = 6$. Where are all the other numbers besides 0 and 1?

[file 02777](#)

Question 4

Boolean algebra is a strange sort of math. For example, the complete set of rules for Boolean addition is as follows:

$$0 + 0 = 0$$

$$0 + 1 = 1$$

$$1 + 0 = 1$$

$$1 + 1 = 1$$

Suppose a student saw this for the very first time, and was quite puzzled by it. What would you say to him or her as an explanation for this? How in the world can $1 + 1 = 1$ and not 2? And why are there no more rules for Boolean addition? Where is the rule for $1 + 2$ or $2 + 2$?

[file 01297](#)

Question 5

Surveying the rules for Boolean addition, the 0 and 1 values seem to resemble the truth table of a very common logic gate. Which type of gate is this, and what does this suggest about the relationship between Boolean addition and logic circuits?

Rules for Boolean addition:

$$0 + 0 = 0$$

$$0 + 1 = 1$$

$$1 + 0 = 1$$

$$1 + 1 = 1$$

[file 01298](#)

Question 6

Surveying the rules for Boolean multiplication, the 0 and 1 values seem to resemble the truth table of a very common logic gate. Which type of gate is this, and what does this suggest about the relationship between Boolean multiplication and logic circuits?

Rules for Boolean multiplication:

$$0 \times 0 = 0$$

$$0 \times 1 = 0$$

$$1 \times 0 = 0$$

$$1 \times 1 = 1$$

[file 01299](#)

Question 7

What is the *complement* of a Boolean number? How do we represent the complement of a Boolean variable, and what logic circuit function performs the complementation function?

[file 01300](#)

Question 8

There are three fundamental operations in Boolean algebra: addition, multiplication, and inversion. Each of these operations has an equivalent logic gate function and an equivalent relay circuit configuration. Draw the corresponding gate and ladder logic diagrams for each:

Boolean addition

$$Z = X + Y$$

Logic gate for addition

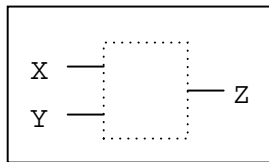

Ladder logic circuit for addition

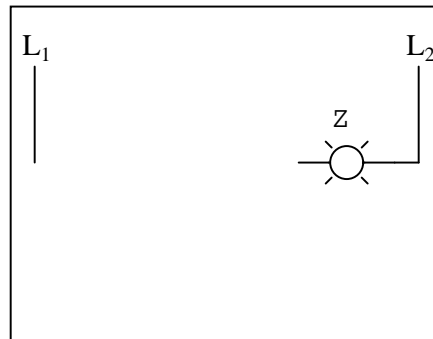

Boolean multiplication

$$Z = X Y$$

Logic gate for multiplication

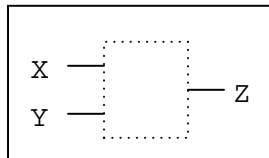

Ladder logic circuit for multiplication

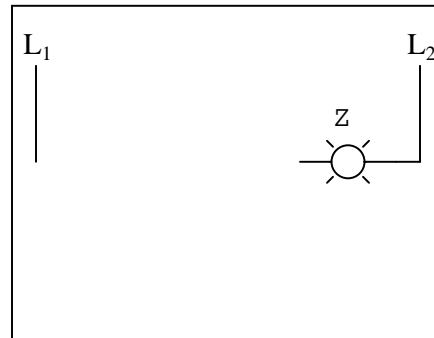

Boolean inversion

$$Z = \overline{X}$$

Logic gate for inversion

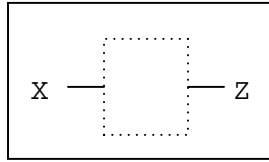

Ladder logic circuit for inversion

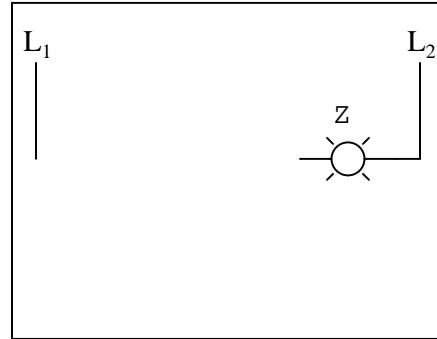

file 02779

Question 9

Write the Boolean expression for each of these logic gates, showing how the output (Q) algebraically relates to the inputs (A and B):

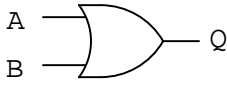

$Q =$

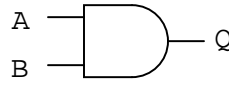

$Q =$

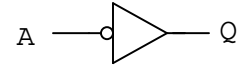

$Q =$

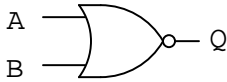

$Q =$

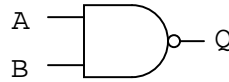

$Q =$

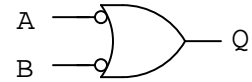

$Q =$

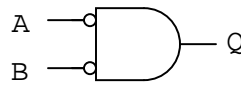

$Q =$

file 02778

Question 10

Write the Boolean expression for each of these relay logic circuits, showing how the output (Q) algebraically relates to the inputs (A and B):

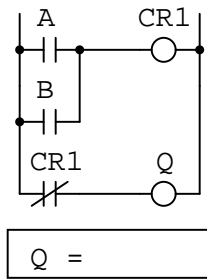
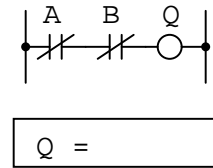
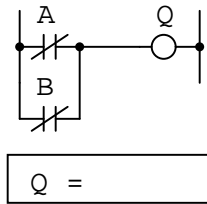
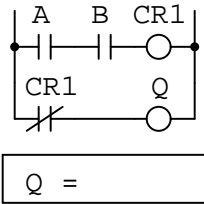
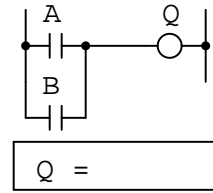
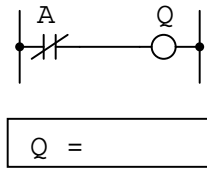
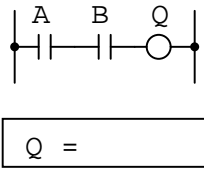

[file 02781](#)

Question 11

Convert the following logic gate circuit into a Boolean expression, writing Boolean sub-expressions next to each gate output in the diagram:

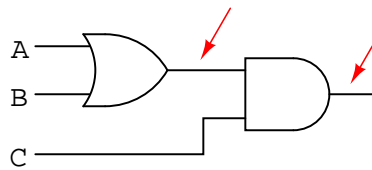

[file 02782](#)

Question 12

Convert the following logic gate circuit into a Boolean expression, writing Boolean sub-expressions next to each gate output in the diagram:

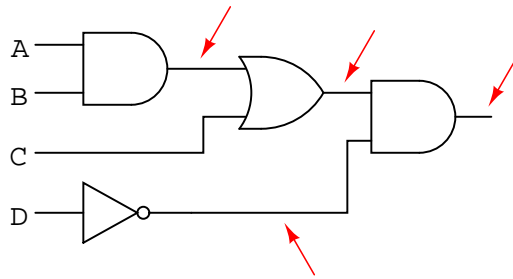

file 01301

Question 13

Convert the following logic gate circuit into a Boolean expression, writing Boolean sub-expressions next to each gate output in the diagram:

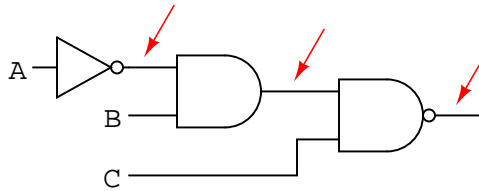

file 02783

Question 14

Convert the following relay logic circuit into a Boolean expression, writing Boolean sub-expressions next to each relay coil and lamp in the diagram:

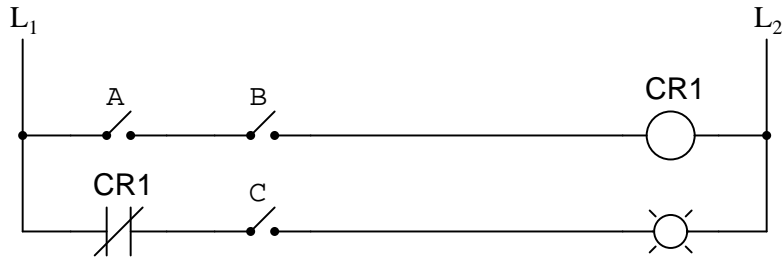

file 02785

Question 15

Convert the following relay logic circuit into a Boolean expression, writing Boolean sub-expressions next to each relay coil and lamp in the diagram:

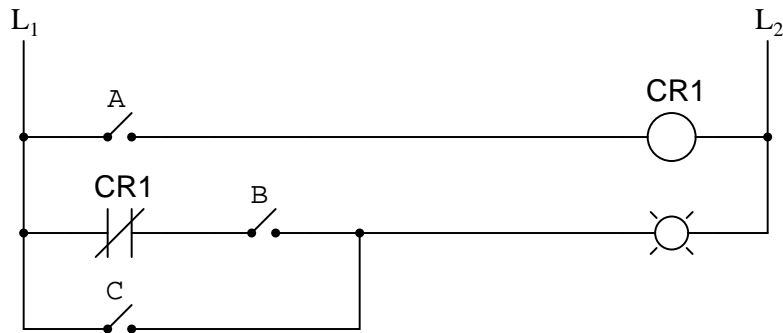

file 02786

Question 16

Convert the following relay logic circuit into a Boolean expression, writing Boolean sub-expressions next to each relay coil and lamp in the diagram:

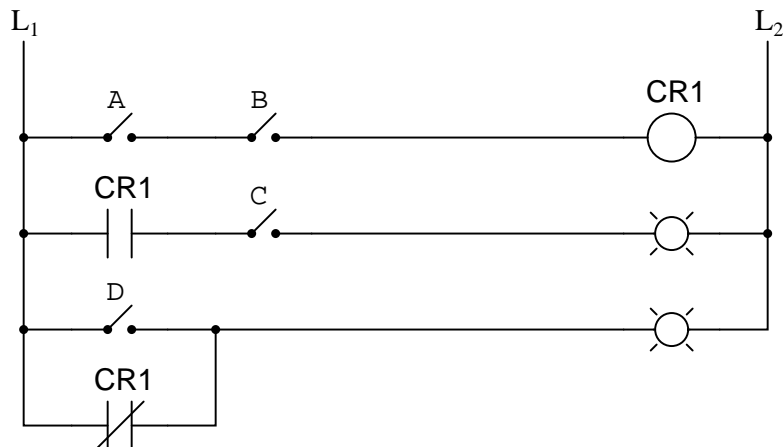

file 01302

Question 17

An automotive engineer wants to design a logic circuit that prohibits the engine in a car from being started unless the driver is pressing the clutch pedal while turning the ignition switch to the "start" position. The purpose of this feature will be to prevent the car from moving forward while being started if ever the transmission is accidentally left in gear.

Suppose we designate the status of the ignition switch "start" position with the Boolean variable S ($1 = \text{start}$; $0 = \text{run or off}$), and the clutch pedal position with the Boolean variable C ($1 = \text{clutch pedal depressed}$; $0 = \text{clutch pedal in normal, unpressed position}$). Write a Boolean expression for the starter solenoid status, given the start switch (S) and clutch (C) statuses. Then, draw a logic gate circuit to implement this Boolean function.

file 02796

Question 18

An engineer hands you a piece of paper with the following Boolean expression on it, and tells you to build a gate circuit to perform that function:

$$A\bar{B} + \bar{C}(A + B)$$

Draw a logic gate circuit for this function.

file 01308

Question 19

A critical electronic system receives DC power from three power supplies, each one feeding through a diode, so that if one power supply develops an internal short-circuit, it will not cause the others to overload:

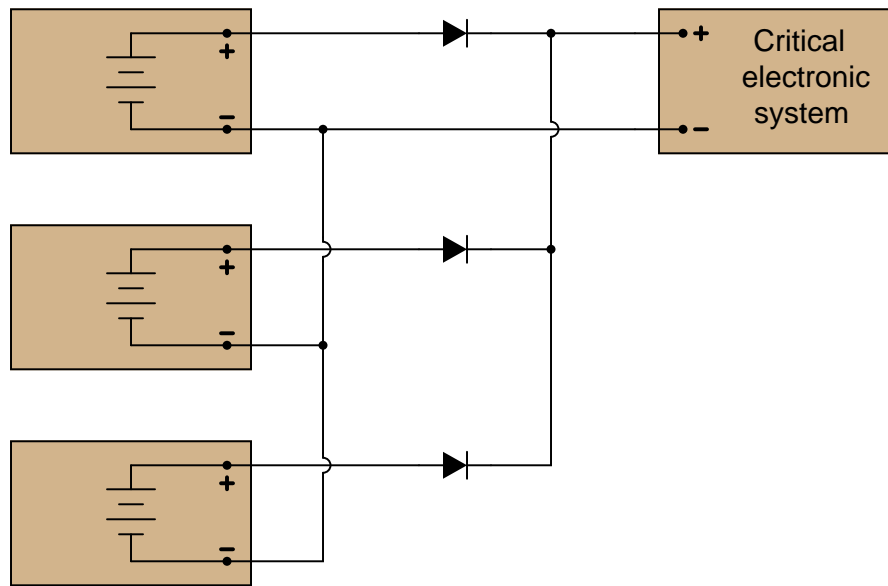

The only problem with this system is that we have no indication of trouble if just one or two power supplies do fail. Since the diode system routes power from any available supply(ies) to the critical system, the system sees no interruption in power if one or even two of the power supplies stop outputting voltage. It would be nice if we had some sort of alarm system installed to alert the technicians of a problem with any of the power supplies, long before the critical system was in jeopardy of losing power completely.

An engineer decides that a relay could be installed at the output of each power supply, prior to the diodes. Contacts from these relays could then be connected to some sort of alarm device (flashing light, bell, etc.) to alert maintenance personnel of any problem:

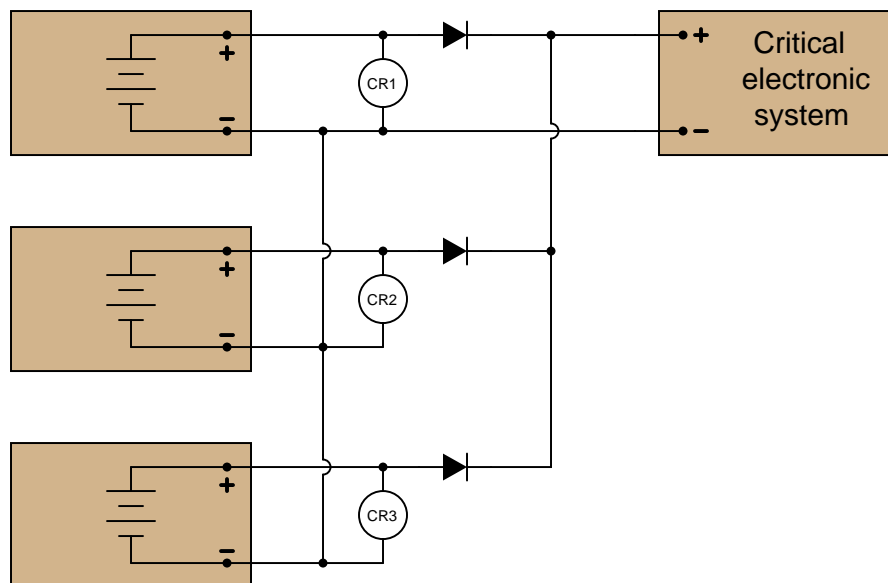

Part 1: Draw a ladder diagram of the relay contacts powering a warning lamp, in such a way that

the lamp energizes if *any one* or more of the power supplies loses output voltage. Write the corresponding Boolean expression for this circuit, using the letters A , B , and C to represent the status of relay coils CR1, CR2, and CR3, respectively.

Part 2: The solution to Part 1 worked, but unfortunately it generated "nuisance alarms" whenever a technician powered any one of the supplies down for routine maintenance. The engineer decides that a two-out-of-three-failed alarm system will be sufficient to warn of trouble, while allowing for routine maintenance without creating unnecessary alarms. Draw a ladder diagram of the relay contacts powering a warning lamp, such that the lamp energizes if *any two* or more power supplies lose output voltage. The Boolean expression for this is $\overline{A}\overline{B} + \overline{B}\overline{C} + \overline{A}\overline{C}$.

Part 3: Management at this facility changed their minds regarding the safety of a two-out-of-three-failed alarm system. They want the alarm to energize if *any one* of the power supplies fails. However, they also realize that nuisance alarms generated during routine maintenance are unacceptable as well. Asking the maintenance crew to come up with a solution, one of the technicians suggests inserting a "maintenance" switch that will disable the alarm during periods of maintenance, allowing for any of the power supplies to be powered down without creating a nuisance alarm. Modify the alarm circuit of part 1's solution to include such a switch, and correspondingly modify the Boolean expression for the new circuit (call the maintenance switch M).

Part 4: During one maintenance cycle, a technician accidentally left the alarm bypass switch (M) actuated after he was done. The system operated with the power failure alarm disabled for weeks. When management discovered this, they were furious. Their next suggestion was to have the bypass switch change the conditions for alarm, such that actuating this " M " switch would turn the system from a one-out-of-three-failed alarm into a two-out-of-three-failed alarm. This way, any one power supply may be taken out of service for routine maintenance, yet the alarm will not be completely de-activated. The system will still alarm if two power supplies were to fail. The simplified Boolean expression for this rather complex function is $\overline{A}\overline{B} + \overline{C}\overline{M} + (\overline{A} + \overline{B})(\overline{C} + \overline{M})$. Draw a ladder diagram for the alarm circuit based on this expression.

file 01307

Question 20

Implement the following Boolean expression in the form of a digital logic circuit:

$$\overline{(\overline{AB} + C)}B$$

Form the circuit by making the necessary connections between pins of these integrated circuits on a solderless breadboard:

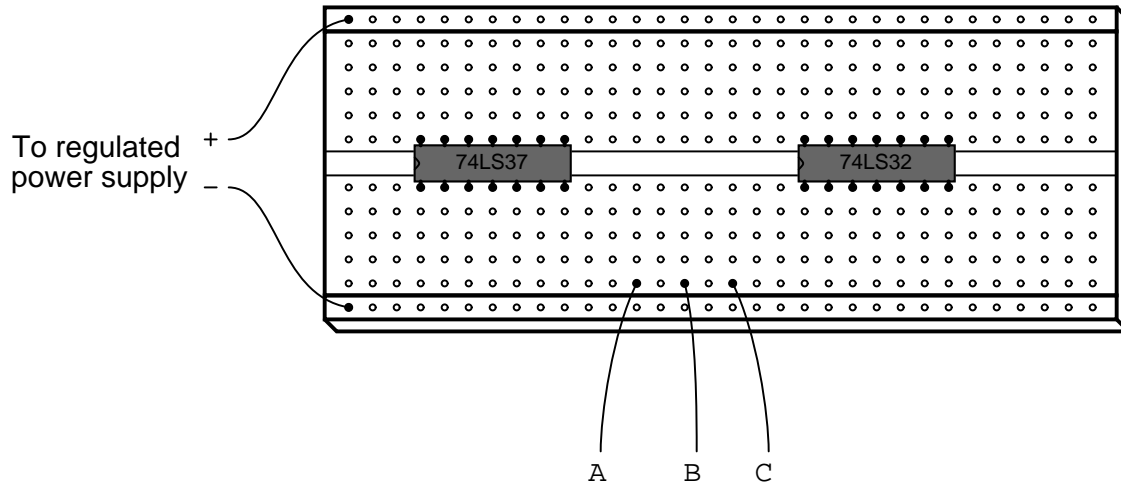

[file 01309](#)

Question 21

Complete the truth tables for these two Boolean expressions:

$$\text{Output} = \overline{A} + B$$

A	B	Output
0	0	
0	1	
1	0	
1	1	

$$\text{Output} = A + \overline{AB}$$

A	B	Output
0	0	
0	1	
1	0	
1	1	

[file 02820](#)

Question 22

Complete the truth tables for these two Boolean expressions:

$$\text{Output} = \bar{A} + \bar{B} + C$$

A	B	C	Output
0	0	0	
0	0	1	
0	1	0	
0	1	1	
1	0	0	
1	0	1	
1	1	0	
1	1	1	

$$\text{Output} = A(B + AC + \bar{A})$$

A	B	C	Output
0	0	0	
0	0	1	
0	1	0	
0	1	1	
1	0	0	
1	0	1	
1	1	0	
1	1	1	

file 02821

Question 23

Like real-number algebra, Boolean algebra is subject to the laws of *commutation*, *association*, and *distribution*. These laws allow us to build different logic circuits that perform the same logic function.

For each of the equivalent circuit pairs shown, write the corresponding Boolean law next to it:

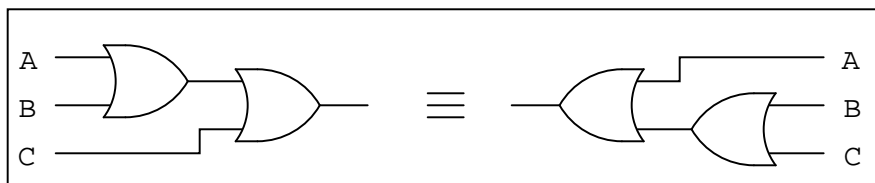
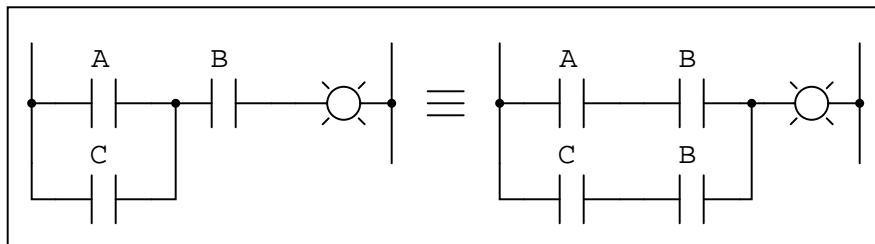
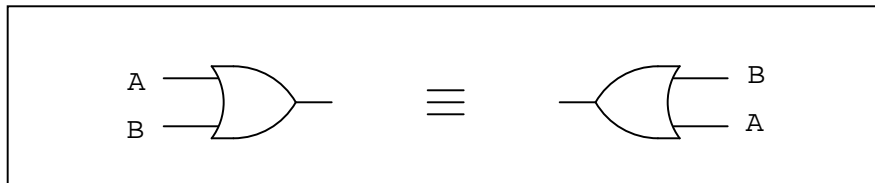
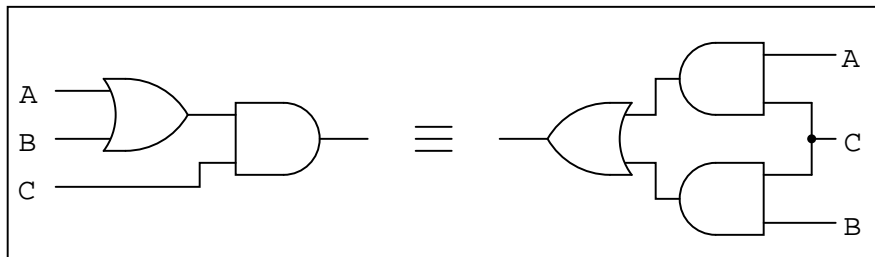
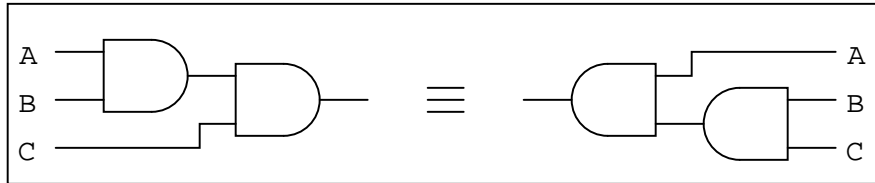
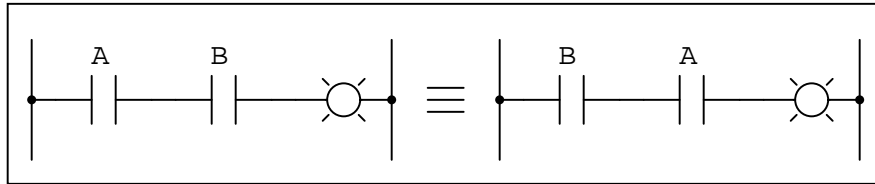

Note: the three short, parallel lines represent "equivalent to" in mathematics.
 file 01303

Question 24

Like real-number algebra, Boolean algebra is subject to certain rules which may be applied in the task of simplifying (reducing) expressions. By being able to algebraically reduce Boolean expressions, it allows us to build equivalent logic circuits using fewer components.

For each of the equivalent circuit pairs shown, write the corresponding Boolean rule next to it:

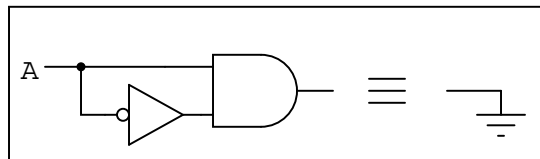
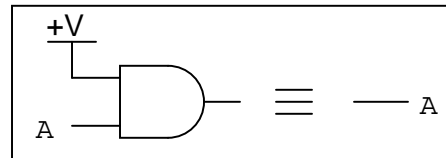
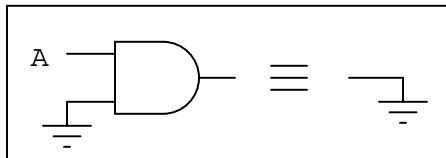
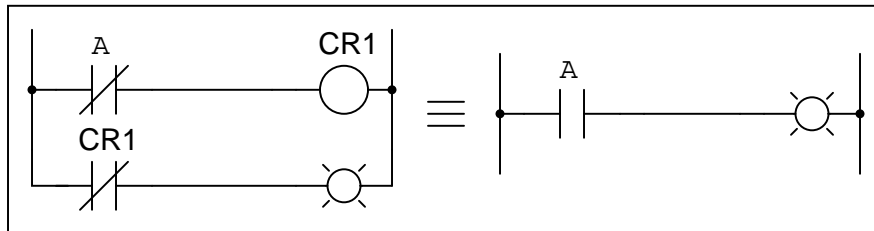
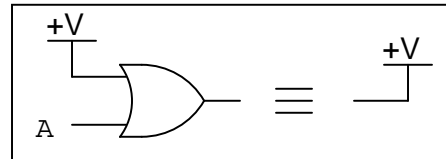
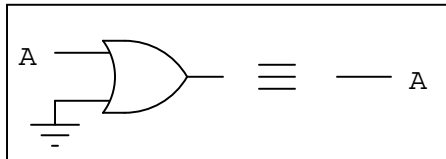
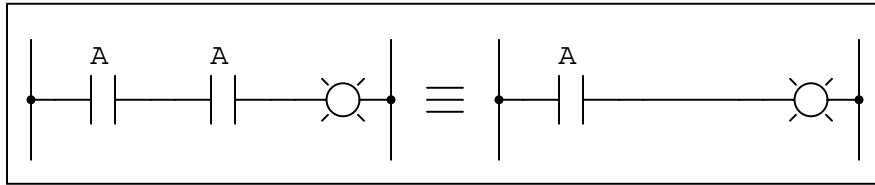
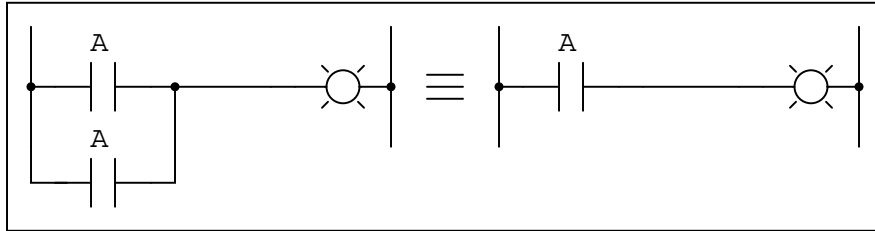

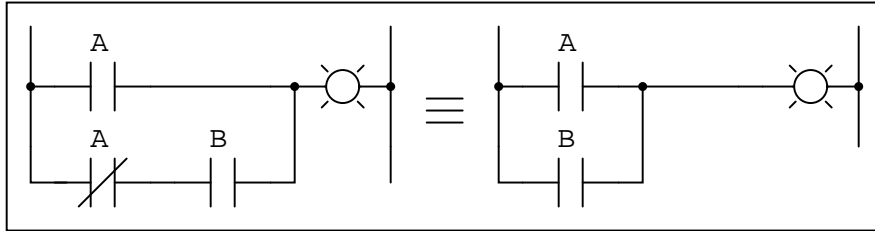
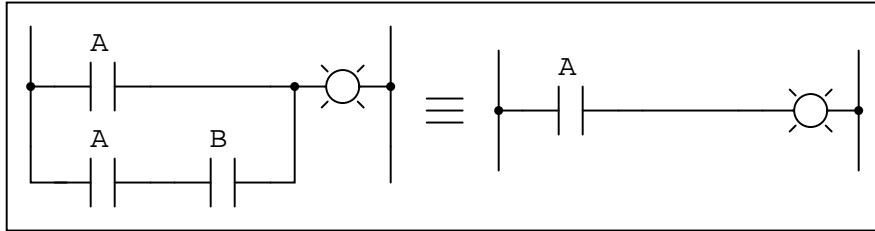
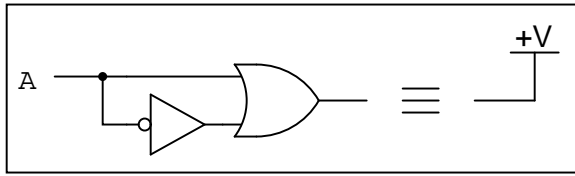

Note: the three short, parallel lines represent "equivalent to" in mathematics.
[file 01306](#)

Question 25

Shown here are six rules of Boolean algebra (these are not the only rules, of course).

- $A + \bar{A} = 1$
- $A + A = A$
- $A + 1 = 1$
- $AA = A$
- $A + AB = A$
- $A + \bar{A}B = A + B$

Determine which rule (or rules) are being used in the following Boolean reductions:

$$\overline{DF} + \overline{DFC} = \overline{DF}$$

$$1 + G = 1$$

$$B + AB = B$$

$$\overline{FE} + \overline{FE} = \overline{FE}$$

$$XYZ + \overline{XYZ} = 1$$

$$GQ + Q = Q$$

$$\overline{H} \overline{H} = \overline{H}$$

$$\overline{CD} + \overline{CD} = \overline{CD}$$

$$EF(EF) = EF$$

$$CD + \overline{C} = \overline{C} + D$$

$$LNM + ML = LM$$

$$A\overline{G}F\overline{C} + F\overline{C}\overline{G} = F\overline{C}\overline{G}$$

$$\overline{M} + 1 = 1$$

$$\overline{BC} + BC = 1$$

$$ABC + CAB = BCA$$

$$S + STV\overline{Q} = S$$

$$\overline{DE}(R + 1) = \overline{DE}$$

$$\overline{RS} \overline{SR} = \overline{RS}$$

$$ABC\overline{D} + D = D + ABC$$

$$AC\overline{B} + CAD\overline{B} = A\overline{B}C$$

$$A + T + \overline{W} + \overline{A} + X = 1$$

$$X\overline{Y}\overline{Z} + \overline{X} = \overline{X} + \overline{Y}\overline{Z}$$

$$\overline{GFH} \overline{HGF} = \overline{FHG}$$

$$C\overline{A}\overline{B} + AB = AB + C$$

file 01305

Question 26

Shown here are eight rules of Boolean algebra (these are not the only rules, of course).

- $A + \overline{A} = 1$
- $A + A = A$
- $A + 1 = 1$
- $AA = A$
- $A\overline{A} = 0$
- $A(B + C) = AB + AC$
- $A + AB = A$
- $A + \overline{A}B = A + B$

Determine which rule is being used in each step of the following Boolean simplification:

$$AB + B(B + \overline{C}) + \overline{B}C$$

$$AB + BB + B\overline{C} + \overline{B}C$$

$$AB + B + B\overline{C} + \overline{B}C$$

$$AB + B + \overline{B}C$$

$$AB + B + C$$

$$B + C$$

file 02805

Question 27

A student makes a mistake somewhere in the process of simplifying the following Boolean expression:

$$AB + A(B + C)$$

$$AB + AB + C$$

$$AB + C$$

Determine where the mistake was made, and what the proper sequence of steps should be to simplify the original expression.

[file 02804](#)

Question 28

Factoring is a powerful simplification technique in Boolean algebra, just as it is in real-number algebra. Show how you can use factoring to help simplify the following Boolean expressions:

$$C + CD$$

$$A\bar{B}C + A\bar{B}\bar{C}$$

$$XY\bar{Z} + XYZ + XYW$$

$$\bar{D}EF + AB + \bar{D}E + 0 + ABC$$

[file 01313](#)

Question 29

Shown here are nine rules of Boolean algebra (these are not the only rules, of course).

- $A + \bar{A} = 1$
- $A + A = A$
- $A + 1 = 1$
- $AA = A$
- $A(1) = A$
- $A\bar{A} = 0$
- $A(B + C) = AB + AC$
- $A + AB = A$
- $A + \bar{A}B = A + B$

Determine which rule is being used in each step of the following Boolean simplification:

$$\bar{C}F + F(A + \bar{B}) + C$$

$$\bar{C}F + AF + \bar{B}F + C$$

$$C + F + AF + \bar{B}F$$

$$C + F(1 + A + \bar{B})$$

$$C + F(1)$$

$$C + F$$

[file 02806](#)

Question 30

Two very important rules of simplification in Boolean algebra are as follows:

- Rule 1: $A + AB = A$
- Rule 2: $A + \bar{A}B = A + B$

Not only are these two rules confusingly similar, but many students find them difficult to successfully apply to situations where a Boolean expression uses different variables (letters), such as here:

$$\bar{R}ST + \bar{R}$$

Here, it is the first rule that applies ($A + AB = A$) and not the second rule ($A + \bar{A}B = A + B$), giving a simplification of:

$$\bar{R}$$

Try to apply these two rules to the following Boolean expressions, identifying which rule directly applies, or if neither rule directly applies:

- $FGH + G$
- $\bar{C} + CF$
- $\overline{ABC} + A$
- $RS + \bar{R}$
- $\overline{AB} + ABC$
- $\overline{ABC} + C$
- $\overline{RVW} + \bar{R}$
- $\overline{X} \overline{Y} Z + \overline{XY}$
- $\overline{J} \overline{K} LM + \overline{JK}$
- $\overline{EHF} + F\bar{E}$

[file 02906](#)

Question 31

Use Boolean algebra to simplify the following expression, then draw a logic gate circuit for the simplified expression:

$$A(B + AB) + AC$$

[file 02818](#)

Question 32

Use Boolean algebra to simplify the following expression, then draw a logic gate circuit for the simplified expression:

$$(A + B)(\bar{A} + \bar{B})$$

[file 02819](#)

Question 33

Use Boolean algebra to simplify the following expression, then draw a logic gate circuit for the simplified expression:

$$\bar{A} \bar{B} \bar{C} + \bar{A} \bar{B} C + A \bar{B} \bar{C} + A \bar{B} C$$

[file 02801](#)

Question 34

Use Boolean algebra to simplify the following logic gate circuit:

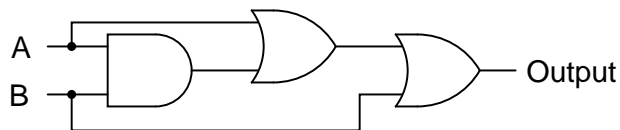

[file 02800](#)

Question 35

Use Boolean algebra to simplify the following logic gate circuit:

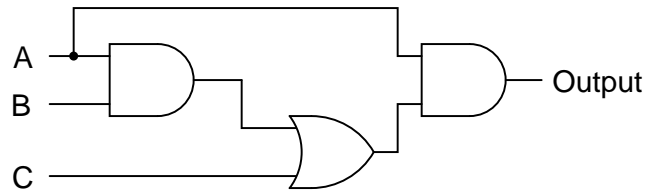

[file 02797](#)

Question 36

Use Boolean algebra to simplify the following logic gate circuit:

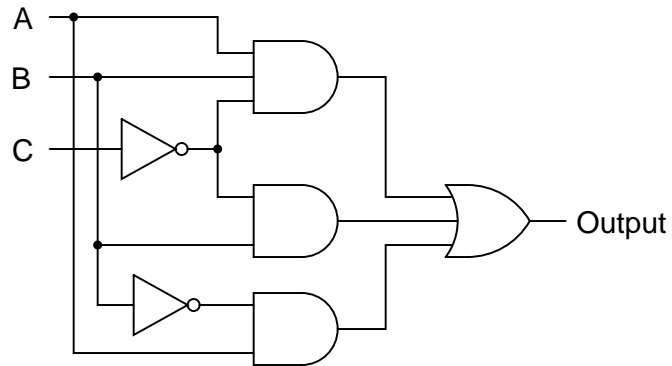

[file 02799](#)

Question 37

Use Boolean algebra to simplify the following relay (ladder logic) circuit:

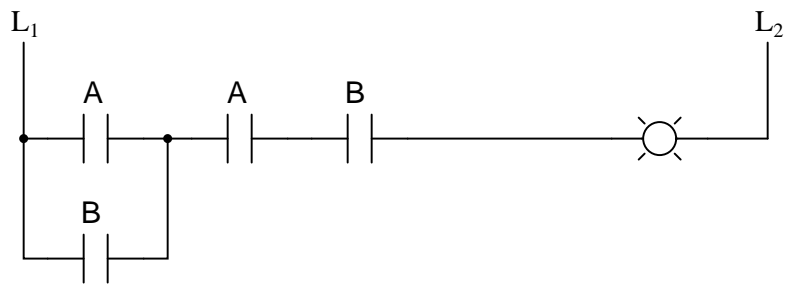

[file 02812](#)

Question 38

Use Boolean algebra to simplify the following relay (ladder logic) circuit:

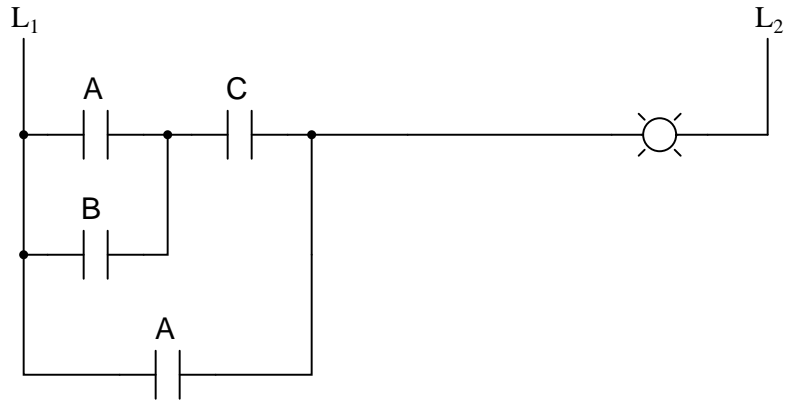

file 02813

Question 39

Use Boolean algebra to simplify the following relay (ladder logic) circuit:

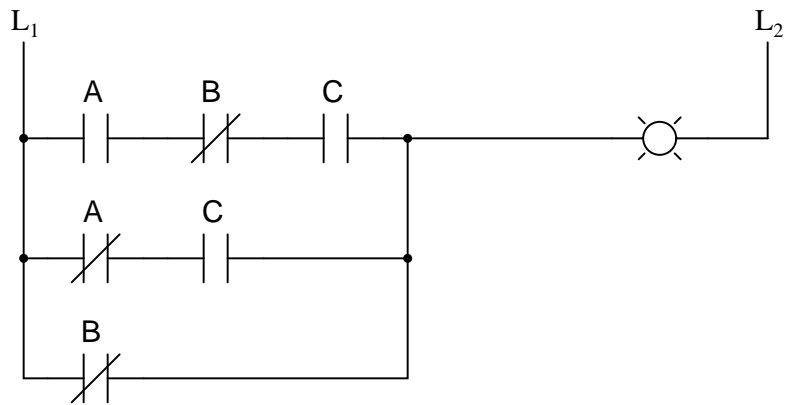

file 02814

Question 40

Use Boolean algebra to simplify the following relay (ladder logic) circuit:

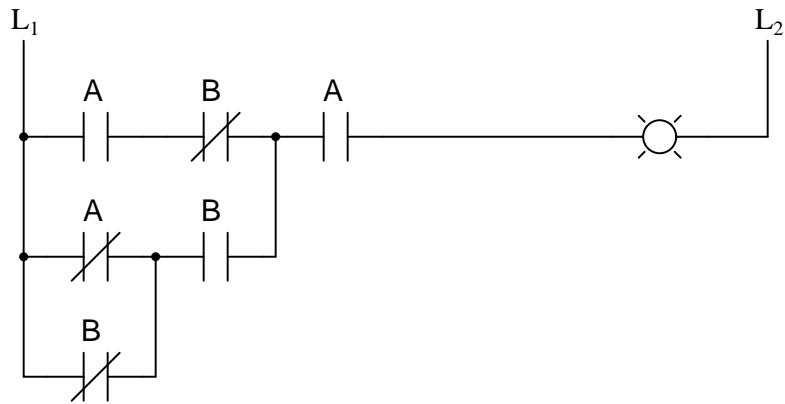

file 02815

Question 41

Identify each of these logic gates by name, and complete their respective truth tables:

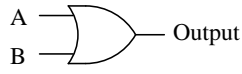

A	B	Output
0	0	
0	1	
1	0	
1	1	

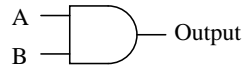

A	B	Output
0	0	
0	1	
1	0	
1	1	

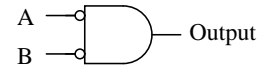

A	B	Output
0	0	
0	1	
1	0	
1	1	

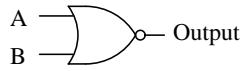

A	B	Output
0	0	
0	1	
1	0	
1	1	

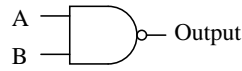

A	B	Output
0	0	
0	1	
1	0	
1	1	

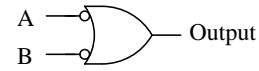

A	B	Output
0	0	
0	1	
1	0	
1	1	

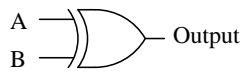

A	B	Output
0	0	
0	1	
1	0	
1	1	

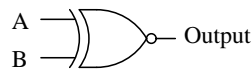

A	B	Output
0	0	
0	1	
1	0	
1	1	

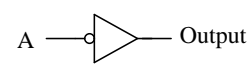

A	Output
0	
1	

file 01249

Question 42

Identify each of these relay logic functions by name (AND, OR, NOR, etc.) and complete their respective truth tables:

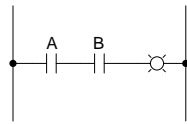

A	B	Output
0	0	
0	1	
1	0	
1	1	

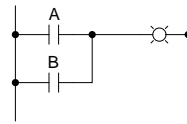

A	B	Output
0	0	
0	1	
1	0	
1	1	

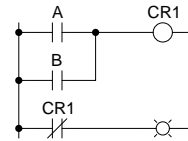

A	B	Output
0	0	
0	1	
1	0	
1	1	

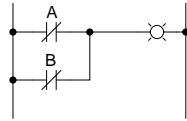

A	B	Output
0	0	
0	1	
1	0	
1	1	

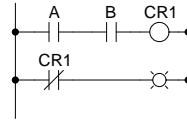

A	B	Output
0	0	
0	1	
1	0	
1	1	

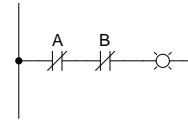

A	B	Output
0	0	
0	1	
1	0	
1	1	

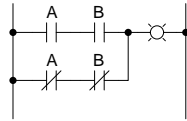

A	B	Output
0	0	
0	1	
1	0	
1	1	

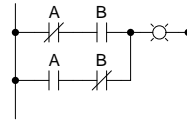

A	B	Output
0	0	
0	1	
1	0	
1	1	

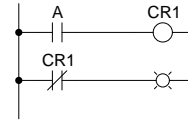

A	Output
0	
1	

file 01335

Question 43

Inspect each of these Boolean expressions, and determine whether each one is a *sum of products*, or a *product of sums*:

$$(B + \bar{C} + D)(\bar{A} + B)$$

$$A\bar{B}\bar{C} + \bar{A}BC$$

$$(X + \bar{Y} + \bar{Z})(\bar{Y} + Z)(\bar{X} + Y)$$

$$\bar{M}\bar{N}\bar{O} + MN\bar{O} + M\bar{N}O$$

$$(X + \bar{Y} + \bar{Z})(\overline{Y + \bar{Z}})$$

$$\overline{ABC} + \bar{A}\bar{B}C$$

file 01324

Question 44

Sum-of-Product Boolean expressions all follow the same general form. As such, their equivalent logic gate circuits likewise follow a common form. Translate each of these SOP expressions into its equivalent logic gate circuit:

$$AB + A\bar{B}$$

$$A\bar{B} + \bar{A}B$$

$$ABC + \bar{A}B\bar{C} + AB\bar{C}$$

file 01325

Question 45

Although it is seldom done, it is possible to express a truth table in verbal form, by describing what conditions must be met in order to generate a "high" output.

Take for example this simple truth table, for an inverter circuit:

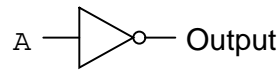

A	Output
0	1
1	0

For this truth table, we could say that the output goes high when A is low. A different way of saying this would be to state that "the output is *true* when \bar{A} is *true*."

Let's look at another example, this time of an AND gate:

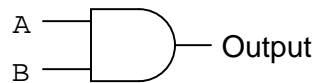

A	B	Output
0	0	0
0	1	0
1	0	0
1	1	1

For this truth table, we could say that the output goes high when A and B are both high. A different way of saying this would be to state that "the output is *true* when A is *true* and B is *true*." To use a half-Boolean, half-verbal description:

A AND B

Examine this logic gate circuit and corresponding truth table:

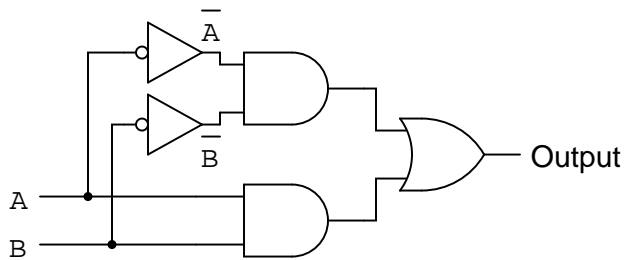

A	B	Output
0	0	1
0	1	0
1	0	0
1	1	1

Express the functionality of this truth table in words. What Boolean conditions must be satisfied ("true") in order for the output to assume a high state?

file 01326

Question 46

Develop a verbal description of this truth table, specifying what conditions must be met ("true" in a Boolean sense) in order for the output to assume a high state:

A	B	C	Output
0	0	0	0
0	0	1	0
0	1	0	0
0	1	1	0
1	0	0	0
1	0	1	1
1	1	0	0
1	1	1	0

Do the same for this truth table as well:

A	B	C	Output
0	0	0	0
0	0	1	1
0	1	0	1
0	1	1	0
1	0	0	0
1	0	1	0
1	1	0	0
1	1	1	0

file 01327

Question 47

Suppose you were faced with the task of writing a Boolean expression for a logic circuit, the internals of which are unknown to you. The circuit has four inputs – each one set by the position of its own micro-switch – and one output. By experimenting with all the possible input switch combinations, and using a logic probe to "read" the output state (at test point TP1), you were able to write the following truth table describing the circuit's behavior:

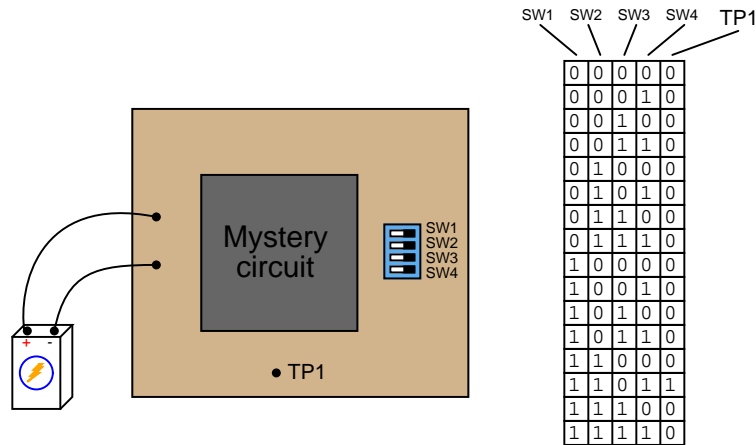

Based on this truth table "description" of the circuit, write an appropriate Boolean expression for this circuit.

[file 01304](#)

Question 48

Write a Boolean SOP expression for this truth table, then simplify that expression as much as possible, and draw a logic gate circuit equivalent to that simplified expression:

A	B	C	Output
0	0	0	0
0	0	1	0
0	1	0	1
0	1	1	0
1	0	0	0
1	0	1	0
1	1	0	1
1	1	1	0

[file 02822](#)

Question 49

Write an SOP expression for this truth table, and then draw a gate circuit diagram corresponding to that SOP expression:

A	B	C	Output
0	0	0	0
0	0	1	0
0	1	0	1
0	1	1	1
1	0	0	0
1	0	1	0
1	1	0	0
1	1	1	1

Finally, simplify this expression using Boolean algebra, and draw a simplified gate circuit based on this new (reduced) Boolean expression.

[file 01333](#)

Question 50

Write an SOP expression for this truth table, and then draw a ladder logic (relay) circuit diagram corresponding to that SOP expression:

A	B	C	Output
0	0	0	0
0	0	1	1
0	1	0	0
0	1	1	1
1	0	0	0
1	0	1	1
1	1	0	0
1	1	1	0

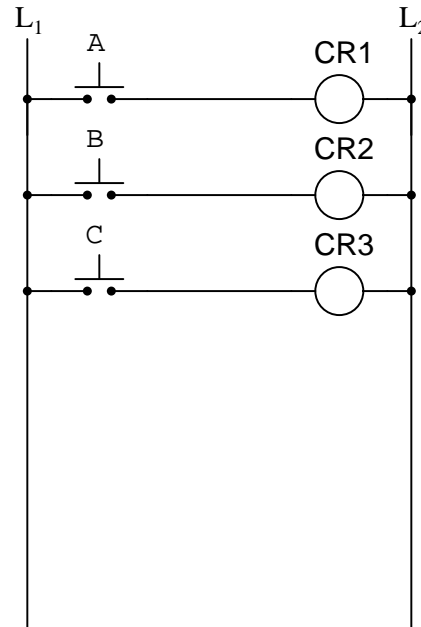

Implement the SOP logic function using contacts of relays CR1, CR2, and CR3. A partial ladder logic diagram has been provided for you.

Finally, simplify this expression using Boolean algebra, and draw a simplified ladder logic diagram based on this new (reduced) Boolean expression. When deciding "how far" to reduce the Boolean expression, choose a form that results in the minimum number of relay contacts in the simplified ladder logic diagram.

[file 01334](#)

Question 51

Design the simplest relay circuit possible (i.e. having the fewest contacts) to implement the following truth table:

A	B	C	Output
0	0	0	0
0	0	1	0
0	1	0	1
0	1	1	0
1	0	0	0
1	0	1	0
1	1	0	1
1	1	1	1

file 02827

Question 52

Product-of-Sum Boolean expressions all follow the same general form. As such, their equivalent logic gate circuits likewise follow a common form. Translate each of these POS expressions into its equivalent logic gate circuit:

$$(A + B)(\bar{A} + \bar{B})$$

$$(\bar{A} + \bar{B})(\bar{A} + B)$$

$$(A + B + C)(\bar{A} + B + \bar{C})(A + B + \bar{C})$$

file 02825

Question 53

Product-of-Sum Boolean expressions all follow the same general form. As such, their equivalent logic gate circuits likewise follow a common form. Translate each of these POS expressions into its equivalent logic gate circuit:

$$(A + B)(A + \bar{B})$$

$$(A + \bar{B})(\bar{A} + B)$$

$$(A + B + C)(\bar{A} + B + \bar{C})(A + B + \bar{C})$$

file 01336

Question 54

In an SOP expression, the minimum requirement for the expression's total value to be equal to 1 is that at least one of the product terms must be equal to 1. For instance, in the following SOP expression, we know that the value will be equal to 1 if $ABC = 1$ or if $A\bar{B}\bar{C} = 1$ or if $AB\bar{C} = 1$:

$$ABC + A\bar{B}\bar{C} + AB\bar{C}$$

What is the minimum requirement for a POS expression to be equal to 0? Take the following POS expression, for instance:

$$(A + B + C)(A + \bar{B} + C)(\bar{A} + B + C)$$

At the very least, what has to occur in order for this expression to equal 0?
file 01337

Question 55

Examine the following truth table:

A	B	Output
0	0	1
0	1	1
1	0	1
1	1	0

We know that this table represents the function of a NAND gate. But suppose we wished to generate a Boolean expression for this gate as though we didn't know what it already was, and we chose to generate an SOP expression based on all the "high" output conditions in the truth table:

$$\overline{A}\overline{B} + \overline{A}B + A\overline{B}$$

Seems like a lot of work for just one gate, doesn't it? The fact that this truth table's output is mostly 1's causes us to have to write a relatively lengthy SOP expression. Wouldn't it be easier if we had a technique to generate a Boolean expression from the single *zero* output condition in this table? If we had such a technique, our resulting Boolean expression would have a lot fewer terms in it!

We know that a Negative-OR gate has the exact same functionality as a NAND gate. We also know that a Negative-OR gate's Boolean representation is $\overline{A} + \overline{B}$. If there is such a thing as a technique for deriving Boolean expressions from the "0" outputs of a truth table, this instance ought to fit it!

Now, examine the following truth table and logic gate circuit:

A	B	Output
0	0	1
0	1	1
1	0	0
1	1	0

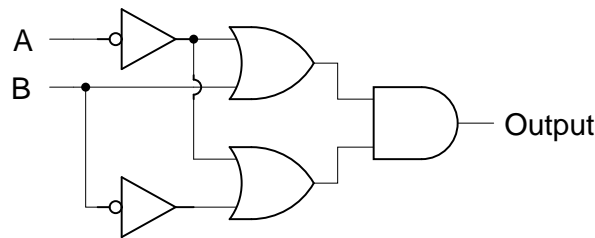

Derive a Boolean expression from the gate circuit shown here, and then compare that expression with the truth table shown for this circuit. Do you see a pattern that would suggest a rule for deriving a Boolean expression directly from the truth table in this example (and the previous example)?

Hint: the rule involves *Product-of-Sums* form.

[file 01338](#)

Question 56

Examine this truth table and then write both SOP and POS Boolean expressions describing the Output:

A	B	C	Output
0	0	0	1
0	0	1	0
0	1	0	1
0	1	1	0
1	0	0	0
1	0	1	1
1	1	0	1
1	1	1	0

Which of those Boolean expressions is simpler for this particular truth table? Which will be easier to reduce to simplest form (for the purpose of creating a gate circuit to implement it)?

[file 02823](#)

Question 57

Write a POS expression for this truth table, and then draw a ladder logic circuit corresponding to that expression:

A	B	C	Output
0	0	0	1
0	0	1	1
0	1	0	1
0	1	1	1
1	0	0	1
1	0	1	0
1	1	0	1
1	1	1	1

[file 01340](#)

Question 58

Write a Boolean expression for this truth table, then simplify that expression as much as possible, and draw a logic gate circuit equivalent to that simplified expression:

A	B	C	Output
0	0	0	1
0	0	1	1
0	1	0	0
0	1	1	1
1	0	0	0
1	0	1	1
1	1	0	1
1	1	1	1

[file 01341](#)

Question 59

Write a Boolean expression for this truth table, then simplify that expression as much as possible, and draw a logic gate circuit equivalent to that simplified expression:

A	B	C	Output
0	0	0	1
0	0	1	1
0	1	0	1
0	1	1	1
1	0	0	1
1	0	1	1
1	1	0	0
1	1	1	0

[file 02826](#)

Question 60

Write two Boolean expressions for the Exclusive-OR function, one written in SOP form and the other written in POS form. Show through Boolean algebra reduction that the two expressions are indeed equivalent to one another. Then, draw the simplest ladder logic circuit possible to implement this function.

[file 01346](#)

Question 61

A *Karnaugh map* is nothing more than a special form of truth table, useful for reducing logic functions into minimal Boolean expressions.

Here is a truth table for a specific three-input logic circuit:

A	B	C	Out
0	0	0	1
0	0	1	1
0	1	0	0
0	1	1	1
1	0	0	0
1	0	1	1
1	1	0	0
1	1	1	0

Complete the following Karnaugh map, according to the values found in the above truth table:

		C	0	1
AB	00			
	01			
	11			
	10			

[file 02834](#)

Question 62

A *Karnaugh map* is nothing more than a special form of truth table, useful for reducing logic functions into minimal Boolean expressions.

Here is a truth table for a specific four-input logic circuit:

A	B	C	D	Out
0	0	0	0	0
0	0	0	1	1
0	0	1	0	0
0	0	1	1	0
0	1	0	0	0
0	1	0	1	1
0	1	1	0	0
0	1	1	1	0
1	0	0	0	0
1	0	0	1	1
1	0	1	0	1
1	0	1	1	1
1	1	0	0	0
1	1	0	1	1
1	1	1	0	0
1	1	1	1	1

Complete the following Karnaugh map, according to the values found in the above truth table:

	CD			
AB \	00	01	11	10
00				
01				
11				
10				

file 01310

Question 63

Here is a truth table for a four-input logic circuit:

A	B	C	D	Out
0	0	0	0	0
0	0	0	1	0
0	0	1	0	0
0	0	1	1	0
0	1	0	0	0
0	1	0	1	1
0	1	1	0	0
0	1	1	1	1
1	0	0	0	0
1	0	0	1	0
1	0	1	0	0
1	0	1	1	0
1	1	0	0	0
1	1	0	1	1
1	1	1	0	0
1	1	1	1	1

If we translate this truth table into a Karnaugh map, we obtain the following result:

		CD			
		00	01	11	10
AB	00	0	0	0	0
	01	0	1	1	0
	11	0	1	1	0
	10	0	0	0	0

Note how the only 1's in the map are clustered together in a group of four:

		CD			
		00	01	11	10
AB	00	0	0	0	0
	01	0	1	1	0
	11	0	1	1	0
	10	0	0	0	0

If you look at the input variables (A, B, C, and D), you should notice that only two of them actually change within this cluster of four 1's. The other two variables hold the same value for each of these conditions where the output is a "1". Identify which variables change, and which stay the same, for this cluster.

[file 01311](#)

Question 64

Here is a truth table for a four-input logic circuit:

A	B	C	D	Out
0	0	0	0	0
0	0	0	1	0
0	0	1	0	0
0	0	1	1	0
0	1	0	0	0
0	1	0	1	0
0	1	1	0	0
0	1	1	1	0
1	0	0	0	0
1	0	0	1	0
1	0	1	0	0
1	0	1	1	0
1	1	0	0	1
1	1	0	1	1
1	1	1	0	1
1	1	1	1	1

If we translate this truth table into a Karnaugh map, we obtain the following result:

		CD			
		00	01	11	10
AB	00	0	0	0	0
	01	0	0	0	0
	11	1	1	1	1
	10	0	0	0	0

Note how the only 1's in the map all exist on the same row:

		CD			
		00	01	11	10
AB	00	0	0	0	0
	01	0	0	0	0
	11	1	1	1	1
	10	0	0	0	0

If you look at the input variables (A, B, C, and D), you should notice that only two of them are constant for each of the "1" conditions on the Karnaugh map. Identify these variables, and remember them.

Now, write an SOP (Sum-of-Products) expression for the truth table, and use Boolean algebra to reduce that raw expression to its simplest form. What do you notice about the simplified SOP expression, in relation to the common variables noted on the Karnaugh map?

Question 65

One of the essential characteristics of Karnaugh maps is that the input variable sequences are always arranged in Gray code sequence. That is, you never see a Karnaugh map with the input combinations arranged in binary order:

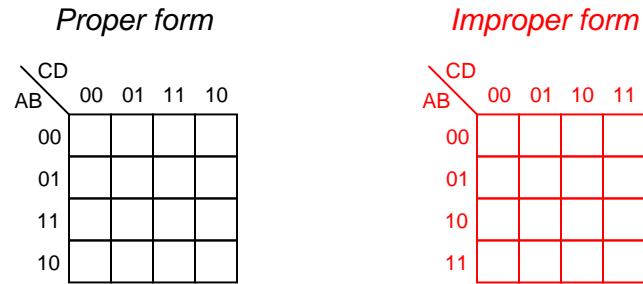

The reason for this is apparent when we consider the use of Karnaugh maps to detect common variables in output sets. For instance, here we have a Karnaugh map with a cluster of four 1's at the center:

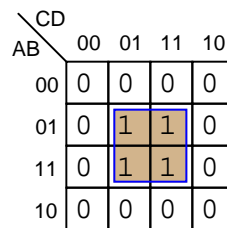

Arranged in this order, it is apparent that two of the input variables have the same values for each of the four "high" output conditions. Re-draw this Karnaugh map with the input variables sequenced in binary order, and comment on what happens. Can you still tell which input variables remain the same for all four output conditions?

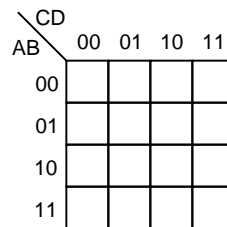

Question 66

Examine this truth table and corresponding Karnaugh map:

A	B	C	D	Out
0	0	0	0	1
0	0	0	1	0
0	0	1	0	1
0	0	1	1	0
0	1	0	0	0
0	1	0	1	0
0	1	1	0	0
0	1	1	1	0
1	0	0	0	1
1	0	0	1	0
1	0	1	0	1
1	0	1	1	0
1	1	0	0	0
1	1	0	1	0
1	1	1	0	0
1	1	1	1	0

AB \ CD	00	01	11	10
00	1	0	0	1
01	0	0	0	0
11	0	0	0	0
10	1	0	0	1

Though it may not be obvious from first appearances, the four "high" conditions in the Karnaugh map actually belong to the same group. To make this more apparent, I will draw a new (oversized) Karnaugh map template, with the Gray code sequences repeated twice along each axis:

AB \ CD	00	01	11	10	00	01	11	10
00								
01								
11								
10								
00								
01								
11								
10								

Fill in this map with the 0 and 1 values from the truth table, and then see if a grouping of four "high" conditions becomes apparent.

[file 01342](#)

Question 67

A student is asked to use Karnaugh mapping to generate a minimal SOP expression for the following truth table:

A	B	C	Output
0	0	0	0
0	0	1	0
0	1	0	0
0	1	1	1
1	0	0	0
1	0	1	1
1	1	0	0
1	1	1	1

Following the truth table shown, the student plots this Karnaugh map:

		C	
		0	1
AB	00	0	0
	01	0	1
	11	0	1
	10	0	1

"This is easy," says the student to himself. "All the '1' conditions fall within the same group!" The student then highlights a triplet of 1's as a single group:

		C	
		0	1
AB	00	0	0
	01	0	1
	11	0	1
	10	0	1

Looking at this cluster of 1's, the student identifies C as remaining constant (1) for all three conditions in the group. Therefore, the student concludes, the minimal expression for this truth table must simply be C .

However, a second student decides to use Boolean algebra on this problem instead of Karnaugh mapping. Beginning with the original truth table and generating a Sum-of-Products (SOP) expression for it, the simplification goes as follows:

$$\overline{A}BC + A\overline{B}C + ABC$$

$$BC(\overline{A} + A) + A\overline{B}C$$

$$BC + A\overline{B}C$$

$$C(B + A\overline{B})$$

$$C(B + A)$$

$$AC + BC$$

Obviously, the answer given by the second student's Boolean reduction ($AC + BC$) does not match the answer given by the first student's Karnaugh map analysis (C).

Perplexed by the disagreement between these two methods, and failing to see a mistake in the Boolean algebra used by the second student, the first student decides to check his Karnaugh mapping again. Upon reflection, it becomes apparent that if the answer really were C , the Karnaugh map would look different. Instead of having three cells with 1's in them, there would be four cells with 1's in them (the output of the function being "1" any time $C = 1$):

AB \ C	0	1
00	0	1
01	0	1
11	0	1
10	0	1

Somewhere, there must have been a mistake made in the first student's grouping of 1's in the Karnaugh map, because the map shown above is the only one proper for an answer of C , and it is not the same as the real map for the given truth table. Explain where the mistake was made, and what the proper grouping of 1's should be.

[file 02836](#)

Question 68

State the rules for properly identifying common groups in a Karnaugh map.

[file 02837](#)

Question 69

A *seven segment decoder* is a digital circuit designed to drive a very common type of digital display device: a set of LED (or LCD) segments that render numerals 0 through 9 at the command of a four-bit code:

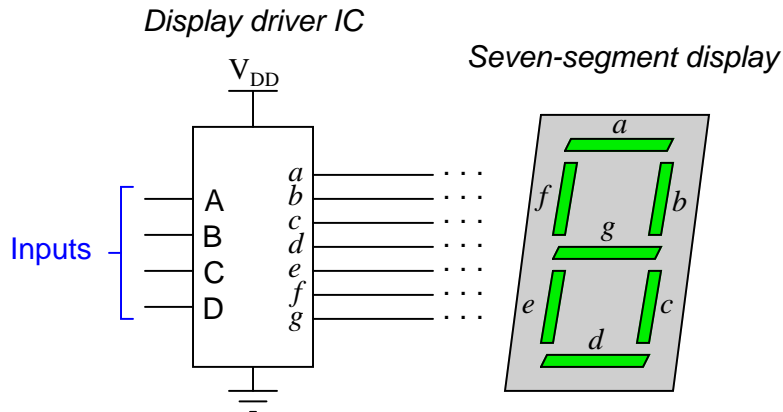

The behavior of the display driver IC may be represented by a truth table with seven outputs: one for each segment of the seven-segment display (*a* through *g*). In the following table, a "1" output represents an active display segment, while a "0" output represents an inactive segment:

D	C	B	A	a	b	c	d	e	f	g	Display
0	0	0	0	1	1	1	1	1	1	0	"0"
0	0	0	1	0	1	1	0	0	0	0	"1"
0	0	1	0	1	1	0	1	1	0	1	"2"
0	0	1	1	1	1	1	1	0	0	1	"3"
0	1	0	0	0	1	1	0	0	1	1	"4"
0	1	0	1	1	0	1	1	0	1	1	"5"
0	1	1	0	1	0	1	1	1	1	1	"6"
0	1	1	1	1	1	1	0	0	0	0	"7"
1	0	0	0	1	1	1	1	1	1	1	"8"
1	0	0	1	1	1	1	1	0	1	1	"9"

A real-life example such as this provides an excellent showcase for techniques such as Karnaugh mapping. Let's take output *a* for example, showing it without all the other outputs included in the truth table:

D	C	B	A	a
0	0	0	0	1
0	0	0	1	0
0	0	1	0	1
0	0	1	1	1
0	1	0	0	0
0	1	0	1	1
0	1	1	0	1
0	1	1	1	1
1	0	0	0	1
1	0	0	1	1

Plotting a Karnaugh map for output *a*, we get this result:

	BA			
DC	00	01	11	10
00	1	0	1	1
01	0	1	1	1
11				
10	1	1		

Identify adjacent groups of 1's in this Karnaugh map, and generate a minimal SOP expression from those groupings.

Note that six of the cells are blank because the truth table does not list all the possible input combinations with four variables (A, B, C, and D). With these large gaps in the Karnaugh map, it is difficult to form large groupings of 1's, and thus the resulting "minimal" SOP expression has several terms.

However, if we do not care about output a 's state in the six non-specified truth table rows, we can fill in the remaining cells of the Karnaugh map with "don't care" symbols (usually the letter X) and use those cells as "wildcards" in determining groupings:

	BA			
DC	00	01	11	10
00	1	0	1	1
01	0	1	1	1
11	X	X	X	X
10	1	1	X	X

With this new Karnaugh map, identify adjacent groups of 1's, and generate a minimal SOP expression from those groupings.

[file 02838](#)

Question 70

When designing a circuit to emulate a truth table such as this where nearly all the input conditions result in "1" output states, it is easier to use Product-of-Sums (POS) expressions rather than Sum-of-Products (SOP) expressions:

A	B	C	Output
0	0	0	1
0	0	1	1
0	1	0	1
0	1	1	1
1	0	0	1
1	0	1	1
1	1	0	0
1	1	1	0

Is it possible to use a Karnaugh map to generate the appropriate POS expression for this truth table, or are Karnaugh maps limited to SOP expressions only? Explain your answer, and how you were able to obtain it.

[file 02839](#)

Question 71

Use a Karnaugh map to generate a simple Boolean expression for this truth table, and draw a relay logic circuit equivalent to that expression:

A	B	C	Output
0	0	0	0
0	0	1	0
0	1	0	1
0	1	1	0
1	0	0	0
1	0	1	0
1	1	0	1
1	1	1	0

file 02840

Question 72

Use a Karnaugh map to generate a simple Boolean expression for this truth table, and draw a gate circuit equivalent to that expression:

A	B	C	D	Output
0	0	0	0	0
0	0	0	1	0
0	0	1	0	0
0	0	1	1	0
0	1	0	0	0
0	1	0	1	0
0	1	1	0	1
0	1	1	1	0
1	0	0	0	0
1	0	0	1	0
1	0	1	0	1
1	0	1	1	1
1	1	0	0	0
1	1	0	1	0
1	1	1	0	1
1	1	1	1	1

file 02841

Question 73

Use a Karnaugh map to generate a simple Boolean expression for this truth table, and draw a gate circuit equivalent to that expression:

A	B	C	D	Output
0	0	0	0	0
0	0	0	1	0
0	0	1	0	0
0	0	1	1	0
0	1	0	0	0
0	1	0	1	0
0	1	1	0	0
0	1	1	1	0
1	0	0	0	1
1	0	0	1	0
1	0	1	0	1
1	0	1	1	1
1	1	0	0	0
1	1	0	1	0
1	1	1	0	1
1	1	1	1	1

file 02842

Question 74

Use a Karnaugh map to generate a simple Boolean expression for this truth table, and draw a relay circuit equivalent to that expression:

A	B	C	D	Output
0	0	0	0	1
0	0	0	1	0
0	0	1	0	0
0	0	1	1	0
0	1	0	0	1
0	1	0	1	0
0	1	1	0	1
0	1	1	1	0
1	0	0	0	1
1	0	0	1	0
1	0	1	0	0
1	0	1	1	0
1	1	0	0	1
1	1	0	1	0
1	1	1	0	1
1	1	1	1	0

file 02843

Question 75

Use a Karnaugh map to generate a simple Boolean expression for this truth table, and draw a relay circuit equivalent to that expression:

A	B	C	D	Output
0	0	0	0	1
0	0	0	1	0
0	0	1	0	1
0	0	1	1	0
0	1	0	0	1
0	1	0	1	1
0	1	1	0	1
0	1	1	1	1
1	0	0	0	1
1	0	0	1	0
1	0	1	0	1
1	0	1	1	0
1	1	0	0	1
1	1	0	1	1
1	1	1	0	1
1	1	1	1	1

[file 02844](#)

Question 76

Complete truth tables for the following gates, and also write the Boolean expression for each gate:

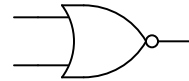
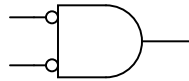

A	B	Output
0	0	
0	1	
1	0	
1	1	

A	B	Output
0	0	
0	1	
1	0	
1	1	

The results should be obvious once the truth tables are both complete. Is there a general principle at work here? Do you think we would obtain similar results with Negative-OR and NAND gates? Explain.

[file 01314](#)

Question 77

Often, we find extended complementation "bars" in Boolean expressions. A simple example is shown here, where a long bar extends over the Boolean expression $A + B$:

$$\overline{A + B}$$

In this particular case, the expression represents the functionality of a NOR gate. Many times in the manipulation of Boolean expressions, it is good to be able to know how to eliminate such long bars. We can't just get rid of the bar, though. There are specific rules to follow for "breaking" long bars into smaller bars in Boolean expressions.

What other type of logic gate has the same functionality (the same truth table) as a NOR gate, and what is its equivalent Boolean expression? The answer to this question will demonstrate what rule(s) we need to follow when we "break" a long complementation bar in a Boolean expression.

Another example we could use for learning how to "break bars" in Boolean algebra is that of the NAND gate:

$$\overline{AB}$$

What other type of logic gate has the same functionality (the same truth table) as a NAND gate, and what is its equivalent Boolean expression? The answer to this question will likewise demonstrate what rule(s) we need to follow when we "break" a long complementation bar in a Boolean expression.

[file 01315](#)

Question 78

What is *DeMorgan's Theorem*?

[file 01323](#)

Question 79

Use DeMorgan's Theorem, as well as any other applicable rules of Boolean algebra, to simplify the following expression so there are no more complementation bars extending over multiple variables:

$$\overline{\overline{AB + AC}}$$

[file 02828](#)

Question 80

Use DeMorgan's Theorem, as well as any other applicable rules of Boolean algebra, to simplify the following expression so there are no more complementation bars extending over multiple variables:

$$\overline{\overline{XYZY}}$$

[file 02829](#)

Question 81

Use DeMorgan's Theorem, as well as any other applicable rules of Boolean algebra, to simplify the following expression so there are no more complementation bars extending over multiple variables:

$$\overline{\overline{J + KJL}}$$

[file 02830](#)

Question 82

Use Boolean algebra to simplify the following logic gate circuit:

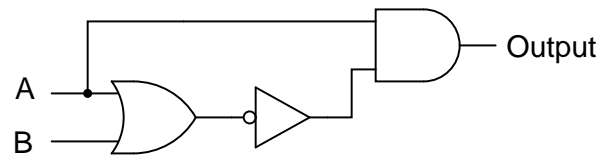

file 02798

Question 83

Write the Boolean expression for this relay logic circuit, then reduce that expression to its simplest form using any applicable Boolean laws and theorems. Finally, draw a new relay circuit based on the simplified Boolean expression that performs the exact same logic function.

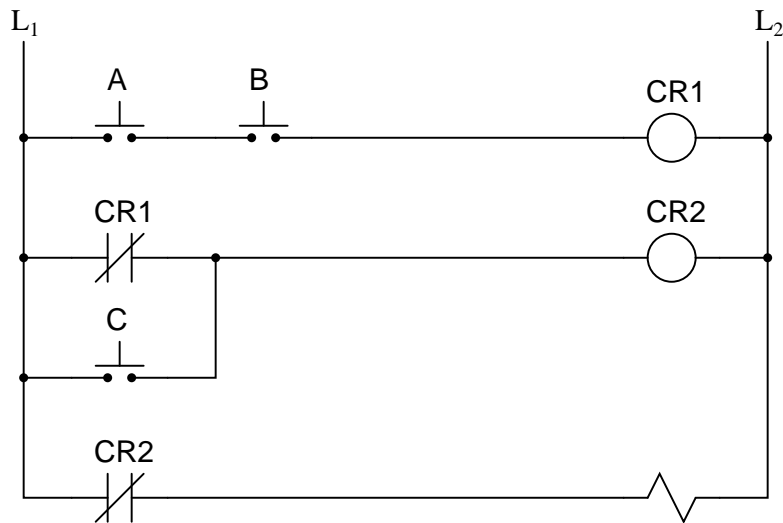

file 01316

Question 84

Write the Boolean expression for this TTL logic gate circuit, then reduce that expression to its simplest form using any applicable Boolean laws and theorems. Finally, draw a new gate circuit diagram based on the simplified Boolean expression, that performs the exact same logic function.

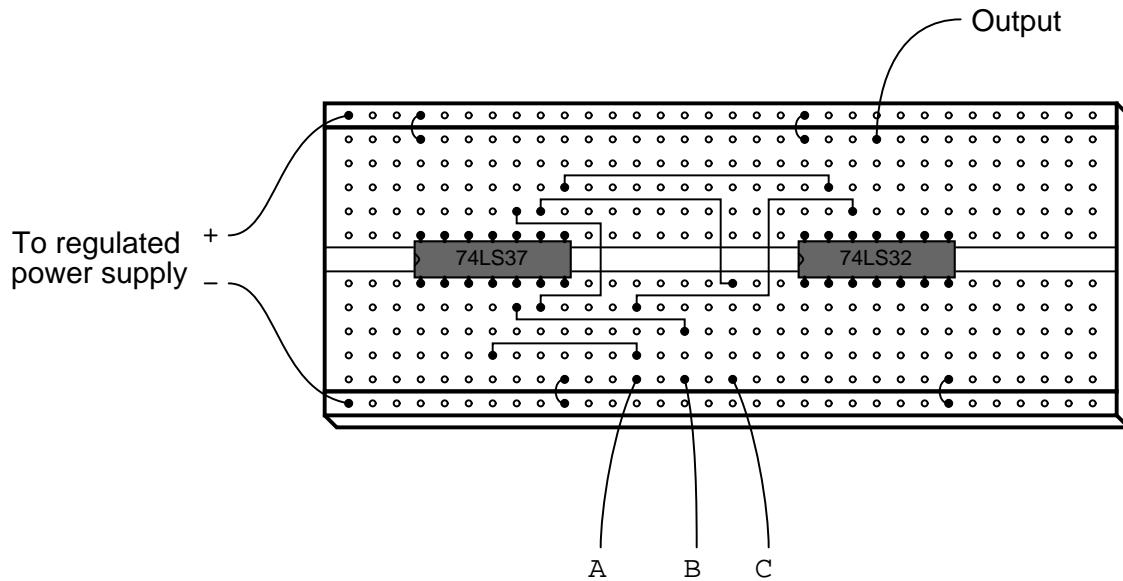

[file 01317](#)

Question 85

A student makes a mistake somewhere in the process of simplifying the Boolean expression $\overline{\overline{XY} + Z}$. Determine what the mistake is:

$$\overline{\overline{XY} + Z}$$

$$\overline{\overline{XY} Z}$$

$$\overline{\overline{X} + \overline{Y} Z}$$

$$X + \overline{Y} Z$$

[file 01319](#)

Question 86

Write the Boolean expression for this TTL logic gate circuit, then reduce that expression to its simplest form using any applicable Boolean laws and theorems. Finally, draw a new gate circuit diagram based on the simplified Boolean expression that performs the exact same logic function.

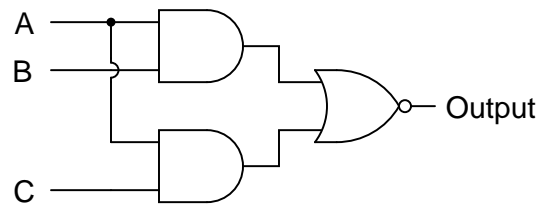

[file 01318](#)

Question 87

Suppose you needed an inverter gate in a logic circuit, but none were available. You do, however, have a spare (unused) NAND gate in one of the integrated circuits. Show how you would connect a NAND gate to function as an inverter.

Use Boolean algebra to show that your solution is valid.

[file 01320](#)

Question 88

Suppose you needed an inverter gate in a logic circuit, but none were available. You do, however, have a spare (unused) NOR gate in one of the integrated circuits. Show how you would connect a NOR gate to function as an inverter.

Use Boolean algebra to show that your solution is valid.

[file 01321](#)

Question 89

The equivalence between NAND gates and Negative-OR gates is something easily verified by an examination of these two gates' respective truth tables, and is often a starting-point for learning about DeMorgan's Theorem:

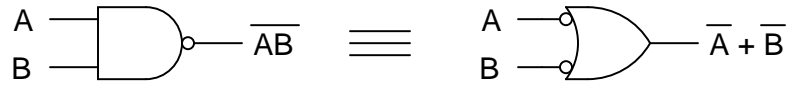

A lesser-known fact is how the equivalence between NAND and Negative-OR gates may be transformed to express an equivalence between two other types of gates, shown here:

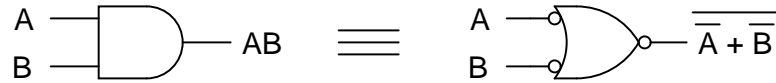

Another example is shown here:

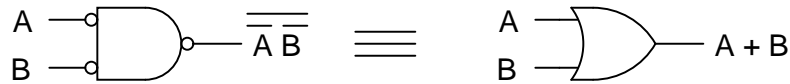

Explain how the first equivalence (between the NAND and the Negative-OR gate) was transformed into the latter two equivalences, both in terms of the gate symbols and their respective Boolean expressions. In other words, explain *how* we can derive the last two examples by manipulating the first example.

[file 03982](#)

Question 90

Suppose we wished to have an AND gate for some logic purpose, but did not have any AND gates on hand. Instead, we only had NOR gates in our parts collection. Draw a diagram whereby multiple NOR gates are connected together to form an AND gate.

[file 03983](#)

Question 91

NAND and NOR gates both have the interesting property of *universality*. That is, it is possible to create any logic function at all, using nothing but multiple gates of either type. The key to doing this is DeMorgan's Theorem, because it shows us how properly applied inversion is able to convert between the two fundamental logic gate types (from AND to OR, and visa-versa).

Using this principle, convert the following gate circuit diagram into one built exclusively of NAND gates (no Boolean simplification, please). Then, do the same using nothing but NOR gates:

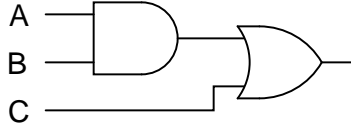

[file 01322](#)

Question 92

An Exclusive-OR gate has the following Boolean expression:

$$A\bar{B} + \bar{A}B$$

Draw the schematic diagram for a gate circuit exhibiting this Boolean function, constructed entirely from NAND gates.

[file 02816](#)

Question 93

An automobile manufacturer needs a logic circuit to perform a specific task in its new line of cars. These cars will be equipped with a "headlight left on" alarm that sounds any time these two conditions are met: headlights on and ignition switch off. Draw the schematic diagram of a logic gate circuit that will implement this alarm, constructed entirely out of NAND gates.

[file 02831](#)

Question 94

Draw a schematic for a logic gate circuit using nothing but two-input NOR gates that mimics the operation of this relay circuit:

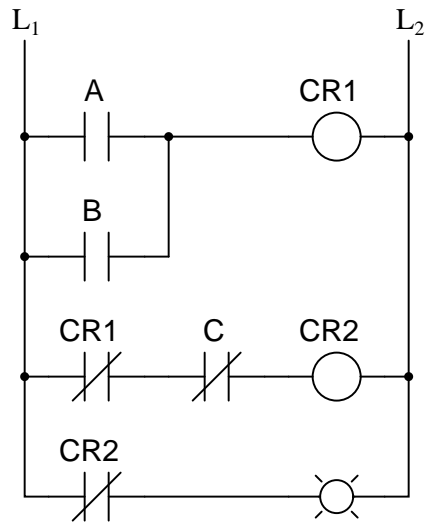

[file 02833](#)

Question 95

Shown here is the ladder logic diagram for a fire alarm system, where the activation of any alarm switch opens that (normally-closed) switch contact and sounds the alarm:

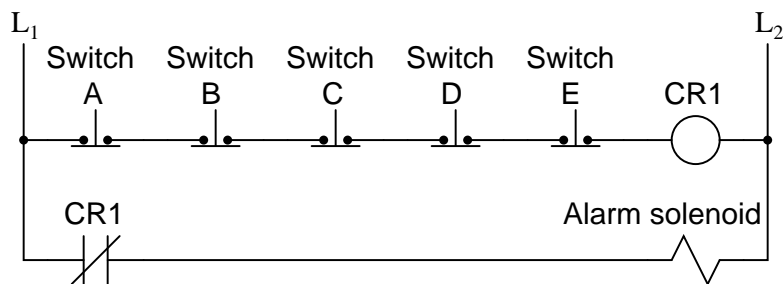

Write the Boolean expression for this relay circuit, then simplify that expression using DeMorgan's Theorem and draw a new relay circuit implementing the simplified expression.

[file 02832](#)

Competency: Gate circuit from Boolean expression	Version:																																				
Boolean expression																																					
Output =																																					
Schematic																																					
Truth table																																					
<table border="1" style="margin: auto;"> <thead> <tr><th colspan="3">Predicted</th></tr> <tr><th>A</th><th>B</th><th>Output</th></tr> </thead> <tbody> <tr><td>0</td><td>0</td><td></td></tr> <tr><td>0</td><td>1</td><td></td></tr> <tr><td>1</td><td>0</td><td></td></tr> <tr><td>1</td><td>1</td><td></td></tr> </tbody> </table>	Predicted			A	B	Output	0	0		0	1		1	0		1	1		<table border="1" style="margin: auto;"> <thead> <tr><th colspan="3">Actual</th></tr> <tr><th>A</th><th>B</th><th>Output</th></tr> </thead> <tbody> <tr><td>0</td><td>0</td><td></td></tr> <tr><td>0</td><td>1</td><td></td></tr> <tr><td>1</td><td>0</td><td></td></tr> <tr><td>1</td><td>1</td><td></td></tr> </tbody> </table>	Actual			A	B	Output	0	0		0	1		1	0		1	1	
Predicted																																					
A	B	Output																																			
0	0																																				
0	1																																				
1	0																																				
1	1																																				
Actual																																					
A	B	Output																																			
0	0																																				
0	1																																				
1	0																																				
1	1																																				

file 02809

Competency: **Gate circuit from truth table** Version:

Truth table

Given				Actual			
A	B	C	Output	A	B	C	Output
0	0	0		0	0	0	
0	0	1		0	0	1	
0	1	0		0	1	0	
0	1	1		0	1	1	
1	0	0		1	0	0	
1	0	1		1	0	1	
1	1	0		1	1	0	
1	1	1		1	1	1	

Schematic

The schematic diagram shows three switches labeled A, B, and C. Each switch is connected to a common output line. Above each switch is a pull-up resistor labeled R_{pullup} connected to a V_{DD} supply. The output line is connected to an LED through a current-limiting resistor labeled R_{limit} . The LED is connected to ground.

file 02134

Competency: NAND gate universality	Version:																														
Description																															
Emulate the specified logic function using nothing but interconnected NAND gates.																															
Emulated function <i>(instructor checks one box)</i>																															
<input type="checkbox"/> AND	<input type="checkbox"/> OR																														
<input type="checkbox"/> NOR																															
Diagram																															
Truth table																															
<p>Predicted</p> <table border="1" style="margin: auto;"> <thead> <tr> <th>A</th> <th>B</th> <th>Output</th> </tr> </thead> <tbody> <tr><td>0</td><td>0</td><td></td></tr> <tr><td>0</td><td>1</td><td></td></tr> <tr><td>1</td><td>0</td><td></td></tr> <tr><td>1</td><td>1</td><td></td></tr> </tbody> </table>	A	B	Output	0	0		0	1		1	0		1	1		<p>Actual</p> <table border="1" style="margin: auto;"> <thead> <tr> <th>A</th> <th>B</th> <th>Output</th> </tr> </thead> <tbody> <tr><td>0</td><td>0</td><td></td></tr> <tr><td>0</td><td>1</td><td></td></tr> <tr><td>1</td><td>0</td><td></td></tr> <tr><td>1</td><td>1</td><td></td></tr> </tbody> </table>	A	B	Output	0	0		0	1		1	0		1	1	
A	B	Output																													
0	0																														
0	1																														
1	0																														
1	1																														
A	B	Output																													
0	0																														
0	1																														
1	0																														
1	1																														

file 02807

Question 99

NAME: _____

Project Grading Criteria

PROJECT: _____

You will receive the highest score for which *all* criteria are met.

100 % (*Must meet or exceed all criteria listed*)

- A. Impeccable craftsmanship, comparable to that of a professional assembly
- B. No spelling or grammatical errors anywhere in *any* document, upon first submission to instructor

95 % (*Must meet or exceed these criteria in addition to all criteria for 90% and below*)

- A. Technical explanation sufficiently detailed to teach from, inclusive of every component (supersedes 75.B)
- B. Itemized parts list complete with part numbers, manufacturers, and (equivalent) prices for *all* components, including recycled components and parts kit components (supersedes 90.A)

90 % (*Must meet or exceed these criteria in addition to all criteria for 85% and below*)

- A. Itemized parts list complete with prices of components purchased for the project, plus total price
- B. No spelling or grammatical errors anywhere in *any* document upon final submission

85 % (*Must meet or exceed these criteria in addition to all criteria for 80% and below*)

- A. “User’s guide” to project function (in addition to 75.B)
- B. Troubleshooting log describing all obstacles overcome during development and construction

80 % (*Must meet or exceed these criteria in addition to all criteria for 75% and below*)

- A. All controls (switches, knobs, etc.) clearly and neatly labeled
- B. All documentation created on computer, not hand-written (including the schematic diagram)

75 % (*Must meet or exceed these criteria in addition to all criteria for 70% and below*)

- A. Stranded wire used wherever wires are subject to vibration or bending
- B. Basic technical explanation of all major circuit sections
- C. Deadline met for working prototype of circuit (Date/Time = _____ / _____)

70 % (*Must meet or exceed these criteria in addition to all criteria for 65%*)

- A. All wire connections sound (solder joints, wire-wrap, terminal strips, and lugs are all connected properly)
- B. No use of glue where a fastener would be more appropriate
- C. Deadline met for submission of fully-functional project (Date/Time = _____ / _____) – supersedes 75.C if final project submitted by that (earlier) deadline

65 % (*Must meet or exceed these criteria in addition to all criteria for 60%*)

- A. Project fully functional
- B. All components securely fastened so nothing is “loose” inside the enclosure
- C. Schematic diagram of circuit

60 % (*Must meet or exceed these criteria in addition to being safe and legal*)

- A. Project minimally functional, with all components located inside an enclosure (if applicable)
- B. Passes final safety inspection (proper case grounding, line power fusing, power cords strain-relieved)

0 % (*If any of the following conditions are true*)

- A. Fails final safety inspection (improper grounding, fusing, and/or power cord strain relieving)
- B. Intended project function poses a safety hazard
- C. Project function violates any law, ordinance, or school policy

file 03173

Question 100

One way to think of logic gate types is to consider what input states guarantee a certain output state. For example, we could describe the function of an AND gate as such:

Any low input guarantees a low output.

Identify what type of gate is represented by each of the following phrases:

- Any low input guarantees a high output.
- Any high input guarantees a low output.
- Any high input guarantees a high output.
- Any difference in the inputs guarantees a high output.
- Any difference in the inputs guarantees a low output.

Also, explain how this sort of gate identification could be useful in troubleshooting logic gate circuits.
[file 03833](#)

Question 101

A different way to view the functions of two-input logic gates is to think of them in terms of *signal controllers*, where the status of one input affects how the other input's signal passes through to the output. The generic schematic diagram for this format is as such:

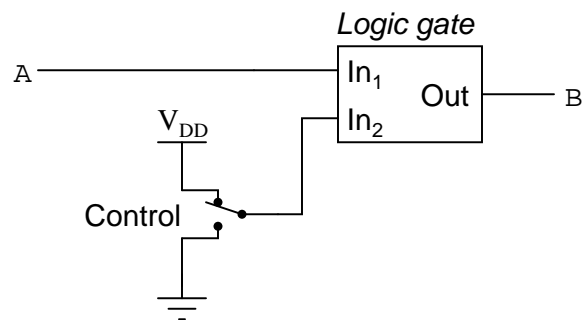

Identify the types of logic gates which do the following (there is more than one type of gate for each of the following rules!):

- $B = A$ when Control is high
- $B = \bar{A}$ when Control is low
- $B = A$ when Control is high
- $B = \bar{A}$ when Control is low

Also, explain how an understanding of this can be helpful in troubleshooting faulted logic gates.
[file 03834](#)

Question 102

Predict how the operation of this logic gate circuit will be affected as a result of the following faults. Consider each fault independently (i.e. one at a time, no multiple faults):

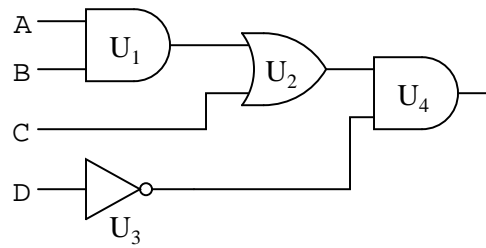

- Output of OR gate U_2 fails low:
- Output of inverter gate U_3 fails low:
- Output of AND gate U_1 fails high:

For each of these conditions, explain *why* the resulting effects will occur.
[file 03831](#)

Question 103

Predict how the operation of this logic gate circuit will be affected as a result of the following faults. Consider each fault independently (i.e. one at a time, no multiple faults):

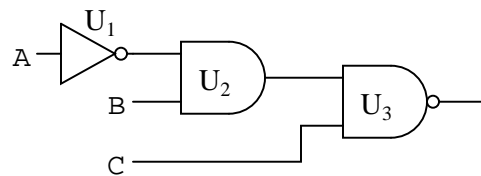

- Output of AND gate U_2 fails low:
- Output of AND gate U_2 fails high:
- Output of inverter gate U_1 fails low:

For each of these conditions, explain *why* the resulting effects will occur.
[file 03832](#)

Question 104

Predict how the operation of this logic gate circuit will be affected as a result of the following faults. Consider each fault independently (i.e. one at a time, no multiple faults):

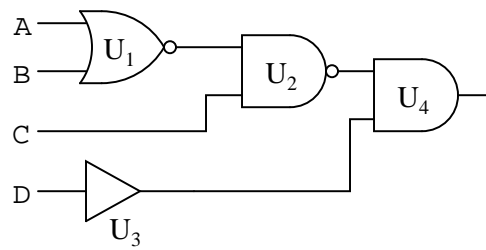

- Output of NAND gate U_2 fails low:
- Output of buffer gate U_3 fails low:
- Output of NOR gate U_1 fails high:

For each of these conditions, explain *why* the resulting effects will occur.

file 03835

Question 105

Predict how the operation of this relay logic circuit will be affected as a result of the following faults. Consider each fault independently (i.e. one at a time, no multiple faults):

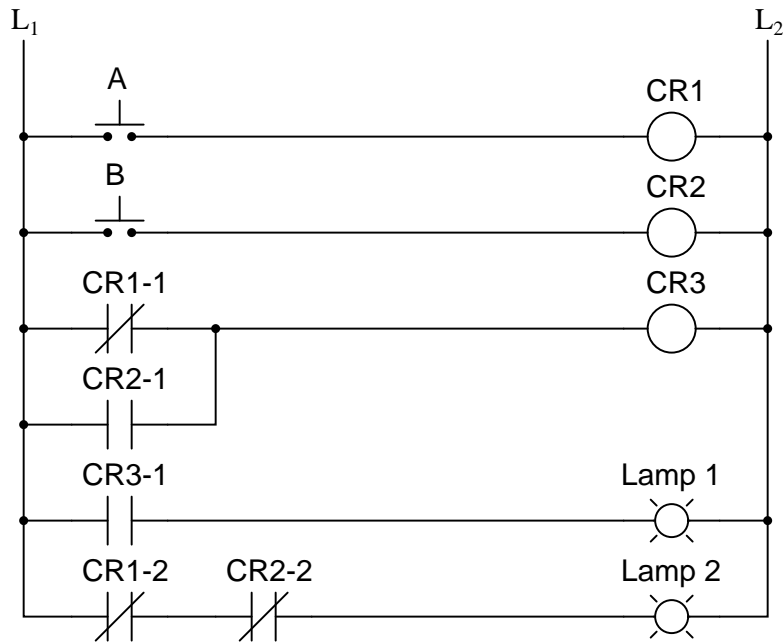

- Pushbutton switch A fails open:
- Relay coil CR2 fails open:
- Relay contact CR1-1 fails open:
- Relay contact CR2-1 fails shorted:
- Relay contact CR2-2 fails shorted:

For each of these conditions, explain *why* the resulting effects will occur.

[file 03836](#)

Question 106

This circuit is supposed to energize a lamp when the input voltage (V_{in}) falls between the two reference voltages set by R_{pot1} and R_{pot2} . Predict how the operation of this circuit will be affected as a result of the following faults. Consider each fault independently (i.e. one at a time, no multiple faults):

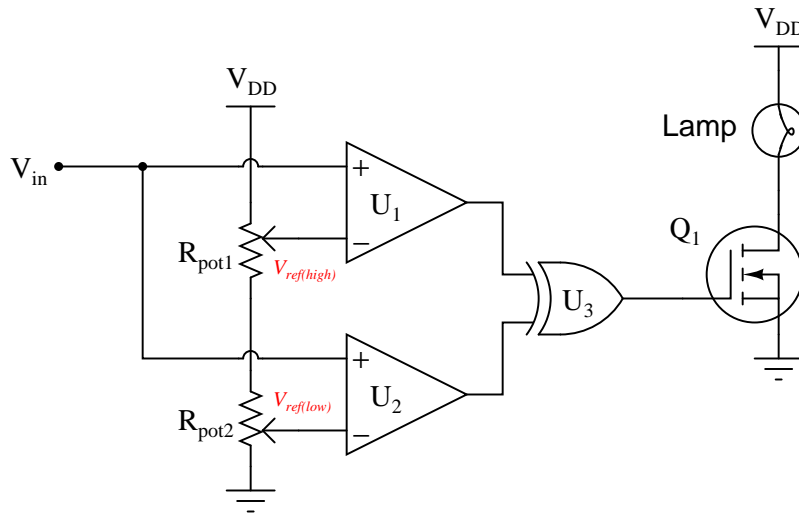

- Comparator U_1 output fails low:
- Comparator U_1 output fails high:
- Comparator U_2 output fails low:
- Comparator U_2 output fails high:
- Wire connecting V_{DD} to R_{pot1} fails open:

For each of these conditions, explain *why* the resulting effects will occur.

file 03837

Question 107

This circuit is supposed to energize the green lamp when the input voltage (V_{in}) falls between the two reference voltages set by R_{pot1} and R_{pot2} , and energize the red lamp when the input voltage exceeds both reference voltages. However, something is wrong with this circuit: the green lamp operates just as it should, but the red lamp never turns on even when it is supposed to.

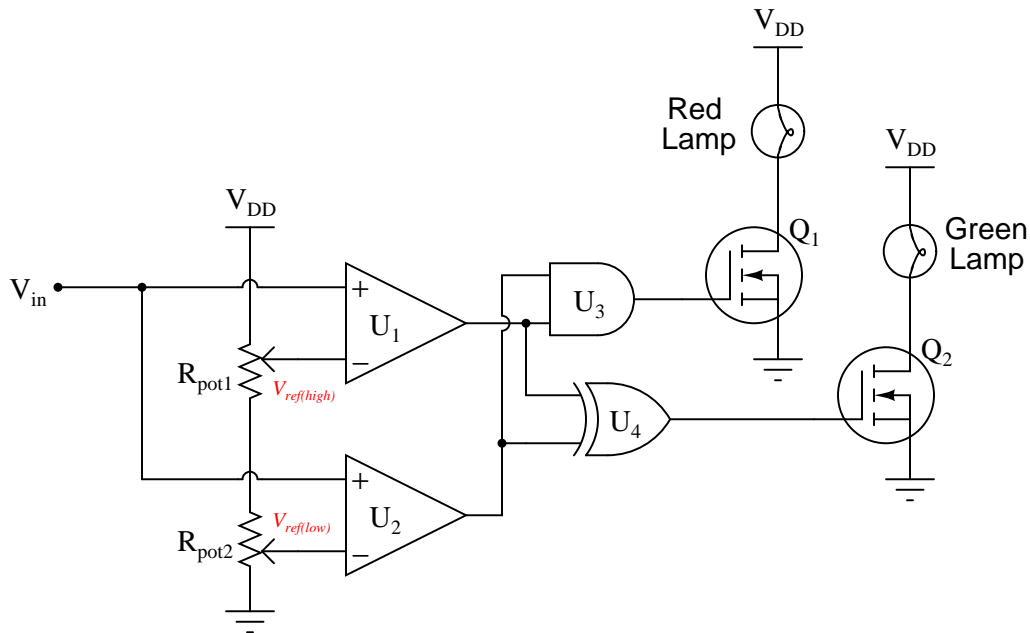

A technician decides to replace the red lamp, thinking it is burned out. This, unfortunately, does not fix the problem. Identify two possible component faults that could account for this problem, and describe what further diagnostic steps you would take to determine the precise nature of the fault.

file 03839

Question 108

A technician decides to check a suspect three-input AND gate using a logic pulser. She touches the logic pulser to each input of the AND gate, while looking for a pulsing signal at the output with a logic probe.

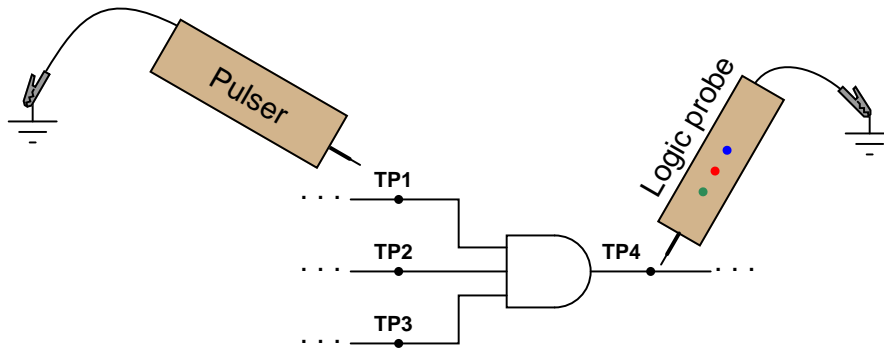

No matter which input test point (TP1, TP2, or TP3) she pulses, though, the output test point (TP4) always reads low. Does this prove the AND gate to be defective? Explain why or why not.

[file 03840](#)

Question 109

There is a problem somewhere in this relay logic circuit. Lamp 2 operates exactly as it should, but lamp 1 never turns on. Identify all possible failures in the circuit that could cause this problem, and then explain how you would troubleshoot the problem as efficiently as possible (taking the least amount of electrical measurements to identify the specific problem).

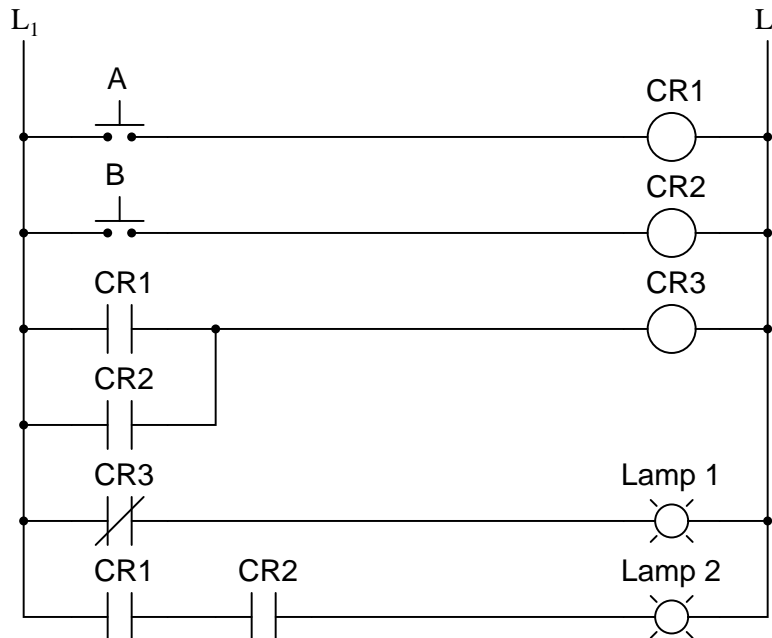

[file 01296](#)

Question 110

The *Law of Distribution* in boolean algebra is identical to the law of distribution in "normal" algebra:

$$A(B + C) = AB + AC \quad \text{Applying the Law of Distribution}$$

While the process of distribution is not difficult to understand, the reverse of distribution (called *factoring*) seems to be a more difficult process for many students to master:

$$AB + AC = A(B + C) \quad \text{Factoring } A \text{ out of each term}$$

Survey the following examples of factoring, and then describe what this process entails. What pattern(s) are you looking for when trying to factor a Boolean expression?

$$CD + AD + BD = D(C + A + B)$$

$$X\bar{Y}\bar{Z} + \bar{X}\bar{Y}Z = \bar{Y}(X\bar{Z} + \bar{X}Z)$$

$$J + JK = J(1 + K)$$

$$AB + ABCD + BCD + B = B(A + ACD + CD + 1)$$

[file 02811](#)

Question 111

Simplify this logic gate circuit, which uses nothing but NAND gates to accomplish a certain logic function:

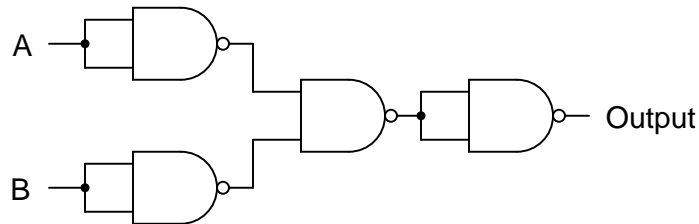

[file 02802](#)

Question 112

Simplify this logic gate circuit, which uses nothing but NOR gates to accomplish a certain logic function:

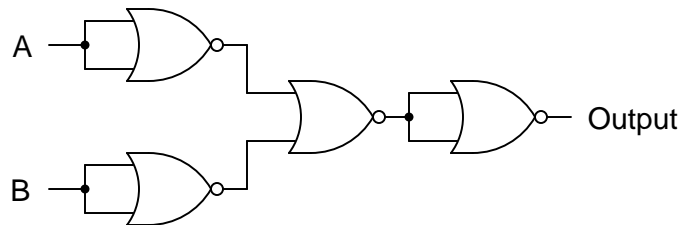

[file 02803](#)

Question 113

Sum-of-Products (SOP) expressions may be implemented by a combination of AND and OR gates, as such:

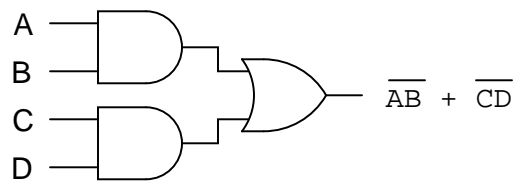

Use DeMorgan's Theorem to prove that this NAND gate circuit performs the exact same function:

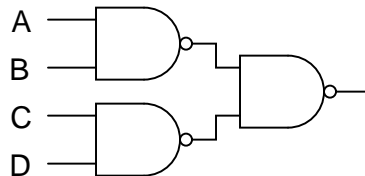

[file 02860](#)

Question 114

Write the Boolean expression for this logic gate circuit, then reduce that expression to its simplest form using any applicable Boolean laws and theorems. Finally, draw a new gate circuit diagram based on the simplified Boolean expression that performs the exact same logic function.

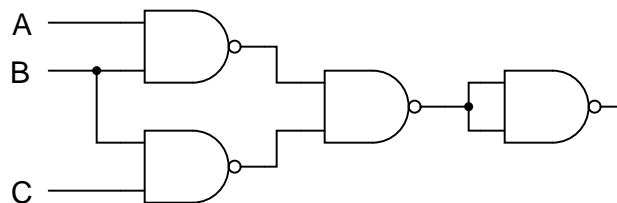

[file 02932](#)

Question 115

Write the Boolean expression for this logic gate circuit, then reduce that expression to its simplest form using any applicable Boolean laws and theorems. Finally, draw a new gate circuit diagram based on the simplified Boolean expression that performs the exact same logic function.

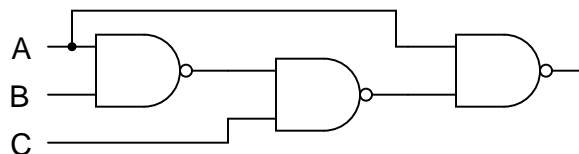

[file 02933](#)

Question 116

A *seven segment decoder* is a digital circuit designed to drive a very common type of digital display device: a set of LED (or LCD) segments that render numerals 0 through 9 at the command of a four-bit code:

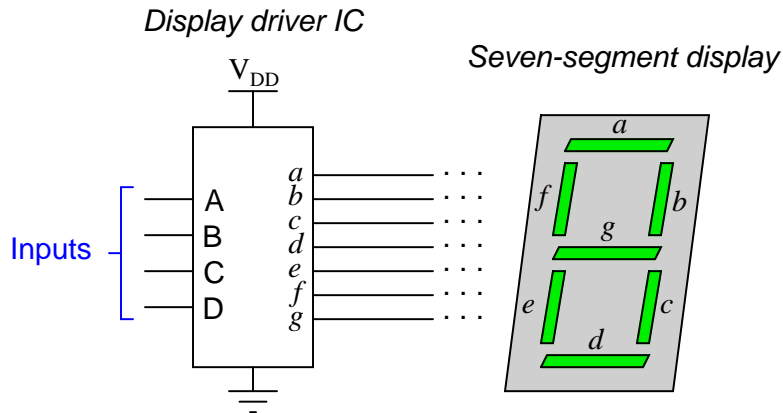

The behavior of the display driver IC may be represented by a truth table with seven outputs: one for each segment of the seven-segment display (*a* through *g*). In the following table, a "1" output represents an active display segment, while a "0" output represents an inactive segment:

D	C	B	A	a	b	c	d	e	f	g	Display
0	0	0	0	1	1	1	1	1	1	0	"0"
0	0	0	1	0	1	1	0	0	0	0	"1"
0	0	1	0	1	1	0	1	1	0	1	"2"
0	0	1	1	1	1	1	1	0	0	1	"3"
0	1	0	0	0	1	1	0	0	1	1	"4"
0	1	0	1	1	0	1	1	0	1	1	"5"
0	1	1	0	1	0	1	1	1	1	1	"6"
0	1	1	1	1	1	1	0	0	0	0	"7"
1	0	0	0	1	1	1	1	1	1	1	"8"
1	0	0	1	1	1	1	1	0	1	1	"9"

Write the unsimplified SOP or POS expressions (choose the most appropriate form) for outputs *a*, *b*, *c*, and *e*.

[file 02824](#)

Answer 1

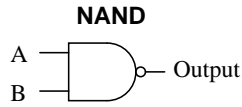

A	B	Output
0	0	1
0	1	1
1	0	1
1	1	0

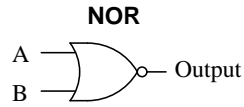

A	B	Output
0	0	1
0	1	0
1	0	0
1	1	0

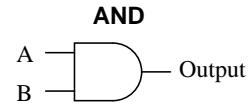

A	B	Output
0	0	0
0	1	0
1	0	0
1	1	1

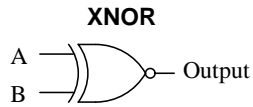

A	B	Output
0	0	1
0	1	0
1	0	0
1	1	1

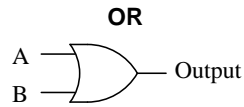

A	B	Output
0	0	0
0	1	1
1	0	1
1	1	1

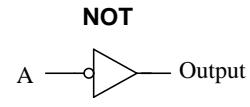

A	Output
0	1
1	0

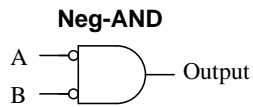

A	B	Output
0	0	1
0	1	0
1	0	0
1	1	0

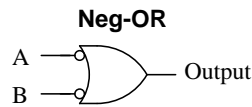

A	B	Output
0	0	1
0	1	1
1	0	1
1	1	0

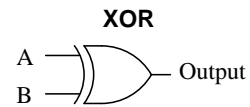

A	B	Output
0	0	0
0	1	1
1	0	1
1	1	0

Answer 2

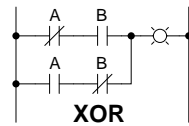

A	B	Output
0	0	0
0	1	1
1	0	1
1	1	0

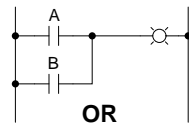

A	B	Output
0	0	0
0	1	1
1	0	1
1	1	1

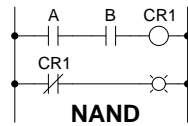

A	B	Output
0	0	1
0	1	1
1	0	1
1	1	0

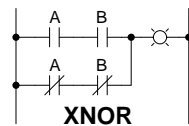

A	B	Output
0	0	1
0	1	0
1	0	0
1	1	1

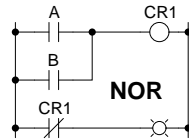

A	B	Output
0	0	1
0	1	0
1	0	0
1	1	0

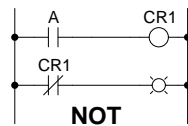

A	Output
0	1
1	0

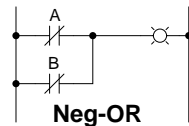

A	B	Output
0	0	1
0	1	1
1	0	1
1	1	0

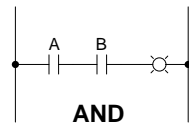

A	B	Output
0	0	0
0	1	0
1	0	0
1	1	1

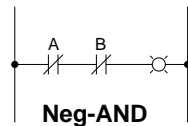

A	B	Output
0	0	1
0	1	0
1	0	0
1	1	0

Answer 3

Boolean quantities can only have one out of two possible values: either 0 or 1. There is no such thing as "2" – or any other digit besides 0 or 1 for that matter – in the set of Boolean numbers!

Answer 4

Boolean quantities can only have one out of two possible values: either 0 or 1. There is no such thing as "2" in the set of Boolean numbers.

Answer 5

This set of Boolean expressions resembles the truth table for an OR logic gate circuit, suggesting that Boolean addition may symbolize the logical OR function.

Answer 6

This set of Boolean expressions resembles the truth table for an AND logic gate circuit, suggesting that Boolean multiplication may symbolize the logical AND function.

Answer 7

A Boolean "complement" is the *opposite* value of a given number. This is represented either by overbars or prime marks next to the variable (i.e. the complement of A may be written as either \bar{A} or A'):

A	\bar{A}
0	1
1	0

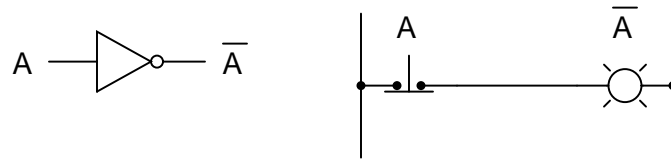

Boolean addition

$$Z = X + Y$$

Logic gate for addition

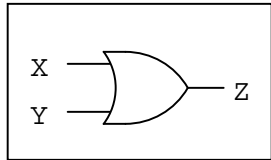

Ladder logic circuit for addition

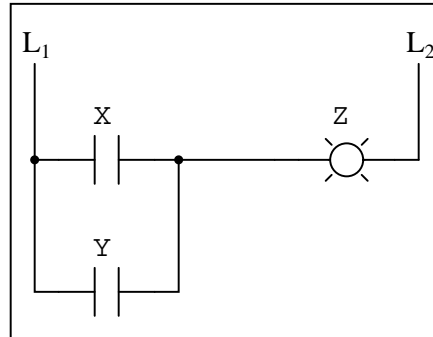

Boolean multiplication

$$Z = X Y$$

Logic gate for multiplication

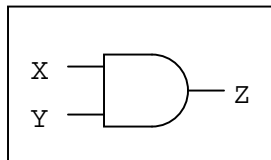

Ladder logic circuit for multiplication

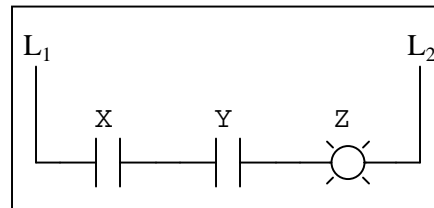

Boolean inversion

$$Z = \overline{X}$$

Logic gate for inversion

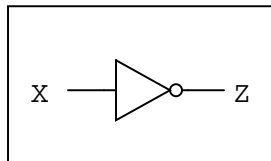

Ladder logic circuit for inversion

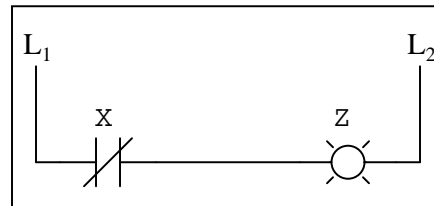

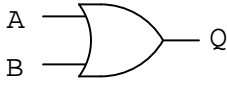

$$Q = A + B$$

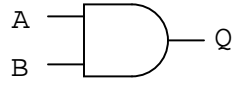

$$Q = AB$$

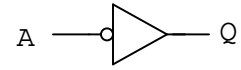

$$Q = \overline{A}$$

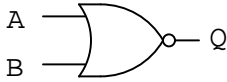

$$Q = \overline{A + B}$$

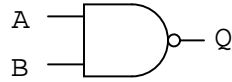

$$Q = \overline{AB}$$

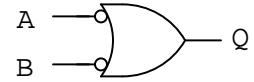

$$Q = \overline{A} + \overline{B}$$

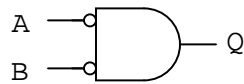

$$Q = \overline{A} \overline{B}$$

Answer 10

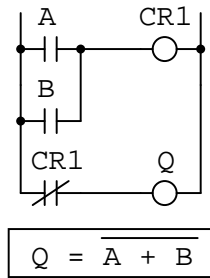
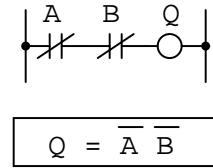
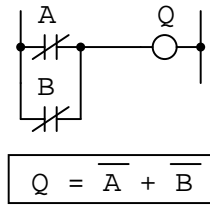
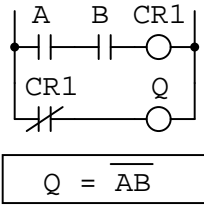
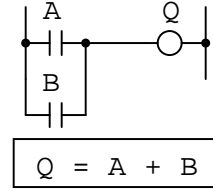
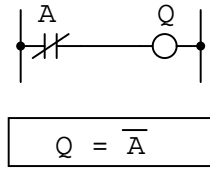
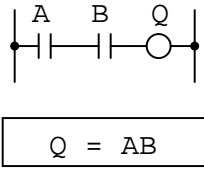

Answer 11

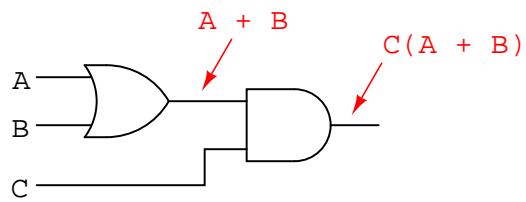

Answer 12

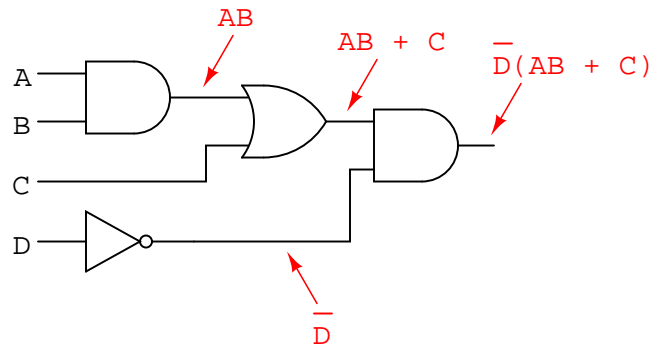

Answer 13

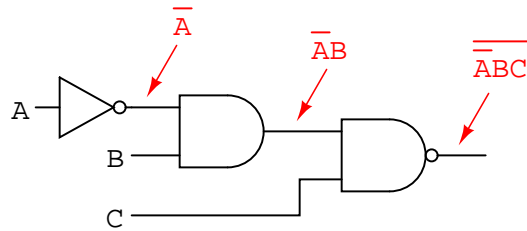

Answer 14

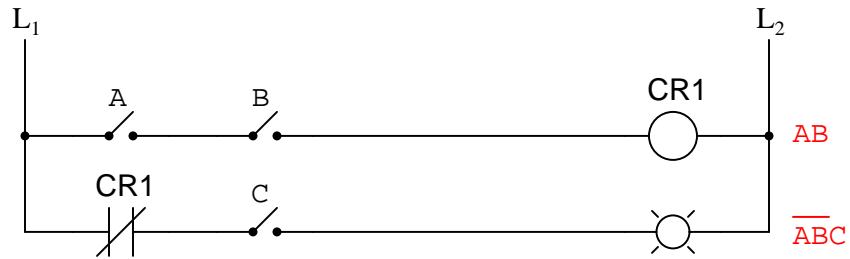

Answer 15

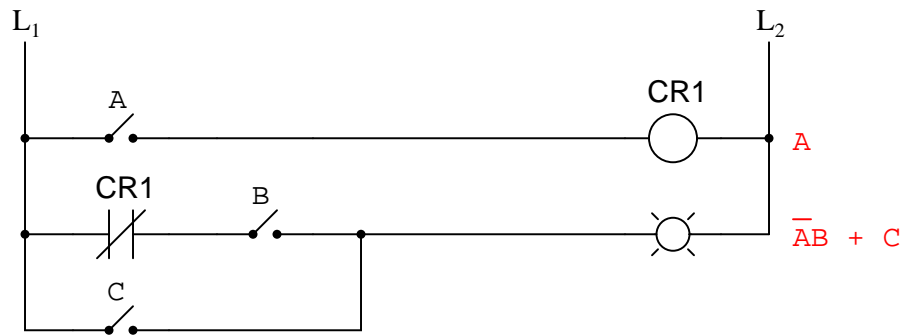

Answer 16

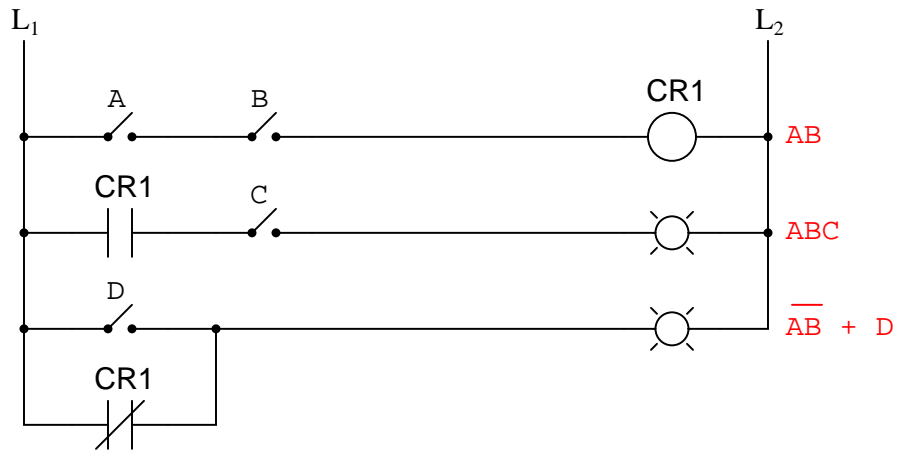

Answer 17

Boolean expression:

$$SC$$

Logic gate circuit:

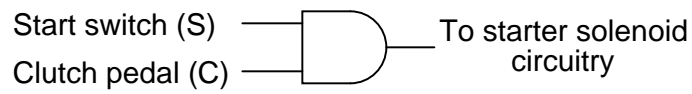

Answer 18

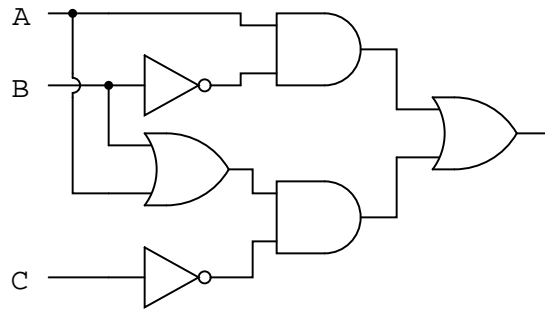

Part 1 solution:

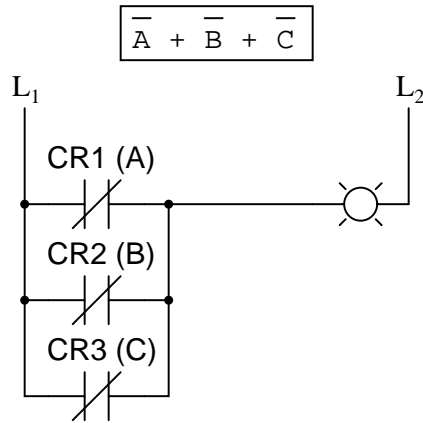

Part 2 solution:

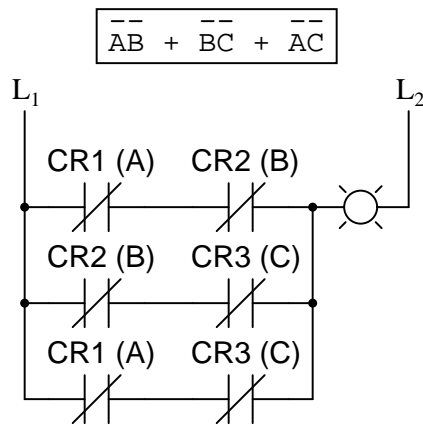

Part 3 solution:

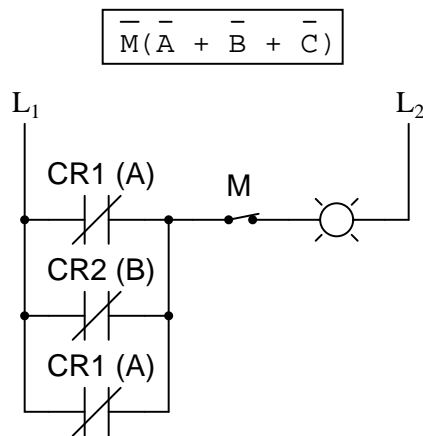

Part 4 solution:

$$\overline{\overline{A}}\overline{B} + \overline{\overline{C}}\overline{M} + (\overline{A} + \overline{B})(\overline{C} + \overline{M})$$

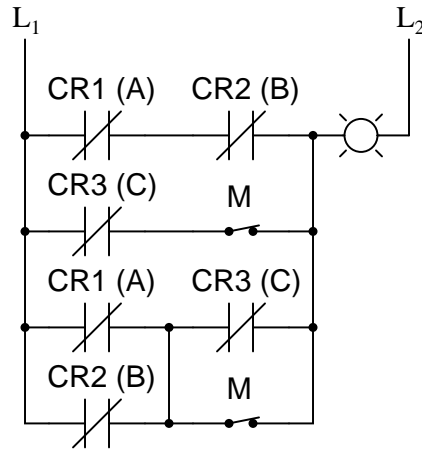

Follow-up question: how many contacts on each relay (and on the maintenance switch "M") are necessary to implement any of these alarm functions?

Challenge question: can you see any way we could reduce the number of relay contacts necessary in the circuit of solutions 2, yet still achieve the same logic functionality (albeit with a different Boolean expression)?

Answer 20

The circuit shown is not the only possible solution to this problem:

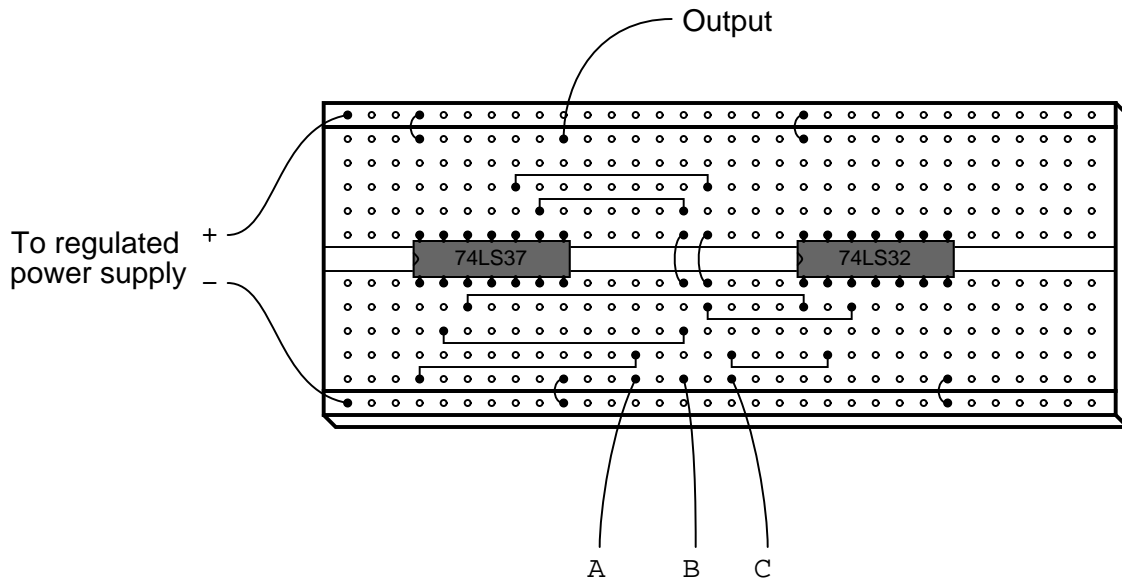

$$\text{Output} = \bar{A} + B$$

A	B	Output
0	0	1
0	1	1
1	0	0
1	1	1

$$\text{Output} = A + \bar{A}B$$

A	B	Output
0	0	0
0	1	1
1	0	1
1	1	1

$$\text{Output} = \bar{A} + \bar{B} + C$$

A	B	C	Output
0	0	0	1
0	0	1	1
0	1	0	1
0	1	1	1
1	0	0	1
1	0	1	1
1	1	0	0
1	1	1	1

$$\text{Output} = A(B + AC + \bar{A})$$

A	B	C	Output
0	0	0	0
0	0	1	0
0	1	0	0
0	1	1	0
1	0	0	0
1	0	1	1
1	1	0	1
1	1	1	1

In order, from top to bottom:

$$AB = BA$$

$$(AB)C = A(BC)$$

$$(A + B)C = AC + BC$$

$$A + B = B + A$$

$$(A + C)B = AB + CB$$

$$(A + B) + C = A + (B + C)$$

In order, from top to bottom, left to right:

$$A + A = A$$

$$AA = A$$

$$A + 0 = A$$

$$A + 1 = 1$$

$$\overline{\overline{A}} = A$$

$$A \times 0 = 0$$

$$A \times 1 = A$$

$$A\overline{A} = 0$$

$$A + \overline{A} = 1$$

$$A + AB = A$$

$$A + \overline{A}B = A + B$$

$$\overline{DF} + \overline{DFC} = \overline{DF} \quad \text{Rule: } A + AB = A$$

$$1 + G = 1 \quad \text{Rule: } A + 1 = 1$$

$$B + AB = B \quad \text{Rule: } A + AB = A$$

$$\overline{FE} + \overline{FE} = \overline{FE} \quad \text{Rule: } A + A = A$$

$$XYZ + \overline{XYZ} = 1 \quad \text{Rule: } A + \overline{A} = 1$$

$$GQ + Q = Q \quad \text{Rule: } A + AB = A$$

$$\overline{H} \overline{H} = \overline{H} \quad \text{Rule: } AA = A$$

$$\overline{CD} + \overline{CD} = \overline{CD} \quad \text{Rule: } A + A = A$$

$$EF(EF) = EF \quad \text{Rule: } AA = A$$

$$CD + \overline{C} = \overline{C} + D \quad \text{Rule: } A + \overline{A}B = A + B$$

$$LNM + ML = LM \quad \text{Rule: } A + AB = A$$

$$A\overline{G}\overline{F}\overline{C} + \overline{F}\overline{C}\overline{G} = \overline{F}\overline{C}\overline{G} \quad \text{Rule: } A + AB = A$$

$$\overline{M} + 1 = 1 \quad \text{Rule: } A + 1 = 1$$

$$\overline{BC} + BC = 1 \quad \text{Rule: } A + \overline{A} = 1$$

$$ABC + CAB = BCA \quad \text{Rule: } A + A = A$$

$$S + STV\overline{Q} = S \quad \text{Rule: } A + AB = A$$

$$\overline{DE}(R + 1) = \overline{DE} \quad \text{Rule: } A + 1 = 1$$

$$\overline{RS} \overline{SR} = \overline{RS} \quad \text{Rule: } AA = A$$

$$ABC\overline{D} + D = D + ABC \quad \text{Rule: } A + \overline{A}B = A + B$$

$$AC\overline{B} + CAD\overline{B} = A\overline{B}C \quad \text{Rule: } A + AB = A$$

$$A + T + \overline{W} + \overline{A} + X = 1 \quad \text{Rule: } A + \overline{A} = 1 \quad \text{Rule: } A + 1 = 1$$

$$X\overline{Y}\overline{Z} + \overline{X} = \overline{X} + \overline{Y}\overline{Z} \quad \text{Rule: } A + \overline{A}B = A + B$$

$$\overline{GFH} \overline{HGF} = \overline{FHG} \quad \text{Rule: } AA = A$$

$$C\overline{A}\overline{B} + AB = AB + C \quad \text{Rule: } A + \overline{A}B = A + B$$

Answer 26

$$AB + B(B + \overline{C}) + \overline{B}C$$

$$\text{Rule: } A(B + C) = AB + AC$$

$$AB + BB + B\overline{C} + \overline{B}C$$

$$\text{Rule: } AA = A$$

$$AB + B + B\overline{C} + \overline{B}C$$

$$\text{Rule: } A + AB = A$$

$$AB + B + \overline{B}C$$

$$\text{Rule: } A + \overline{A}B = A + B$$

$$AB + B + C$$

$$\text{Rule: } A + AB = A$$

$$B + C$$

Answer 27

An error was made in the second step (distribution). The correct sequence of steps is as follows:

$$AB + A(B + C)$$

$$AB + AB + AC$$

$$AB + AC$$

$$A(B + C)$$

Answer 28

You will be expected to show your work (including all factoring) in your answers!

$$C + CD = C$$

$$A\bar{B}C + A\bar{B}\bar{C} = A\bar{B}$$

$$XY\bar{Z} + XYZ + XYW = XY$$

$$\bar{D}EF + AB + \bar{D}E + 0 + ABC = AB + \bar{D}E$$

$$\overline{C}F + F(A + \overline{B}) + C$$

Rule: $A(B + C) = AB + AC$

$$\overline{C}F + AF + \overline{B}F + C$$

Rule: $A + \overline{A}B = A + B$

$$C + F + AF + \overline{B}F$$

(Factoring)

$$C + F(1 + A + \overline{B})$$

Rule: $A + 1 = 1$

$$C + F(1)$$

Rule: $A(1) = A$

$$C + F$$

- $FGH + G = G$ (Rule 1)
- $\overline{C} + CF = \overline{C} + F$ (Rule 2)
- $\overline{A}BC + A$ (Neither rule applies)
- $RS + \overline{R} = \overline{R} + S$ (Rule 2)
- $\overline{A}B + ABC = \overline{A}B + C$ (Rule 2)
- $\overline{A}BC + C = C$ (Rule 1)
- $\overline{R}V\overline{W} + \overline{R} = \overline{R}$ (Rule 1)
- $\overline{X}\overline{Y}Z + \overline{X}\overline{Y}$ (Neither rule applies)
- $\overline{J}\overline{K}LM + \overline{J}K$ (Neither rule applies)
- $\overline{E}HF + F\overline{E} = \overline{E}F$ (Rule 1)

Answer 31

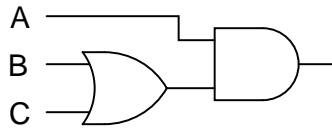

Answer 32

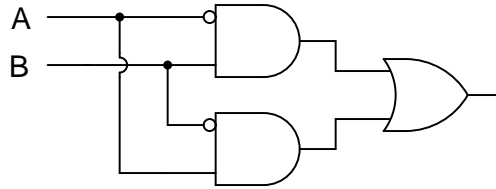

Challenge question: identify the specific logic gate type that will perform this Boolean function using just a single gate.

Answer 33

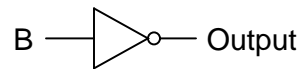

Answer 34

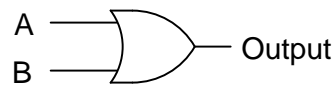

Answer 35

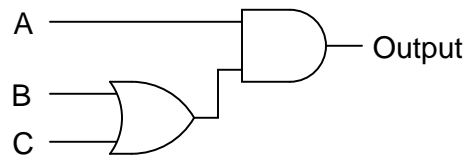

Answer 36

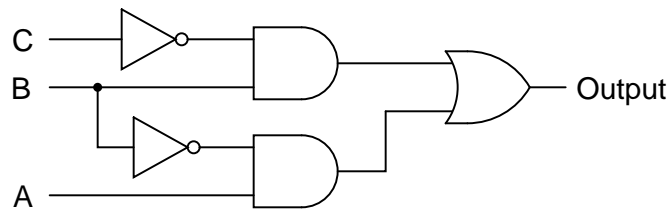

Answer 37



Answer 38

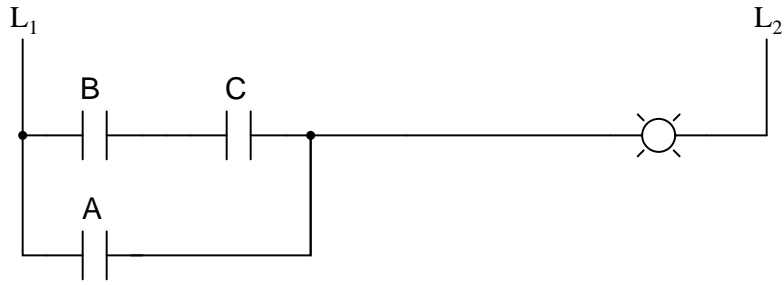

Answer 39

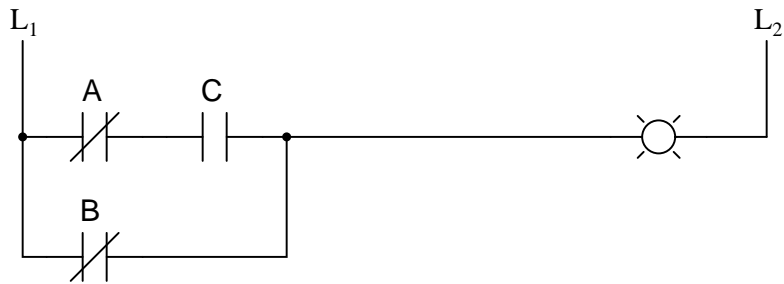

Answer 40



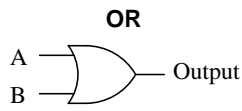

A	B	Output
0	0	0
0	1	1
1	0	1
1	1	1

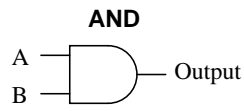

A	B	Output
0	0	0
0	1	0
1	0	0
1	1	1

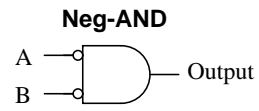

A	B	Output
0	0	1
0	1	0
1	0	0
1	1	0

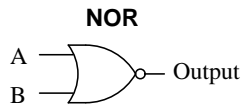

A	B	Output
0	0	1
0	1	0
1	0	0
1	1	0

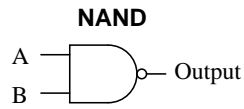

A	B	Output
0	0	1
0	1	1
1	0	1
1	1	0

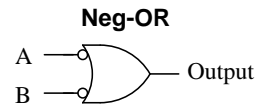

A	B	Output
0	0	1
0	1	1
1	0	1
1	1	0

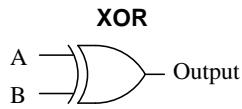

A	B	Output
0	0	0
0	1	1
1	0	1
1	1	0

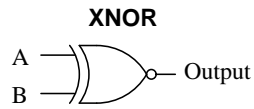

A	B	Output
0	0	1
0	1	0
1	0	0
1	1	1

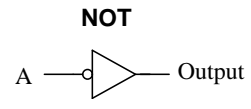

A	Output
0	1
1	0

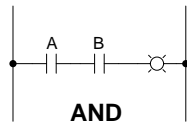

A	B	Output
0	0	0
0	1	0
1	0	0
1	1	1

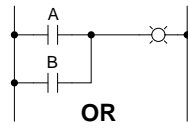

A	B	Output
0	0	0
0	1	1
1	0	1
1	1	1

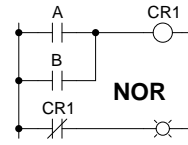

A	B	Output
0	0	1
0	1	0
1	0	0
1	1	0

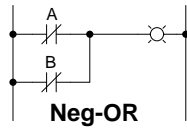

A	B	Output
0	0	1
0	1	1
1	0	1
1	1	0

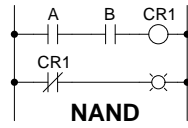

A	B	Output
0	0	1
0	1	1
1	0	1
1	1	0

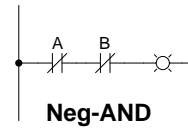

A	B	Output
0	0	1
0	1	0
1	0	0
1	1	0

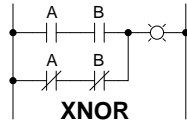

A	B	Output
0	0	1
0	1	0
1	0	0
1	1	1

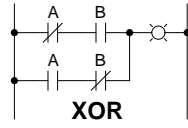

A	B	Output
0	0	0
0	1	1
1	0	1
1	1	0

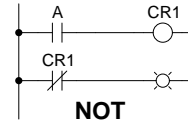

A	Output
0	1
1	0

$$(B + \bar{C} + D)(\bar{A} + B) \quad \mathbf{POS}$$

$$A\bar{B}\bar{C} + \bar{A}BC \quad \mathbf{SOP}$$

$$(X + \bar{Y} + \bar{Z})(\bar{Y} + Z)(\bar{X} + Y) \quad \mathbf{POS}$$

$$\bar{M}\bar{N}\bar{O} + MN\bar{O} + M\bar{N}O \quad \mathbf{SOP}$$

The last two expressions are "trick" questions: while technically being the product of summed variables, and the sum of multiplied (product) variables, respectively, do not follow "standard" POS and SOP forms, because they both have long complementation bars:

$$(X + \bar{Y} + \bar{Z})(\bar{Y} + \bar{Z})$$

$$\bar{A}\bar{B}\bar{C} + \bar{A}BC$$

For an expression to properly follow the SOP or POS canonical form, no complementation bar should cover more than one variable!

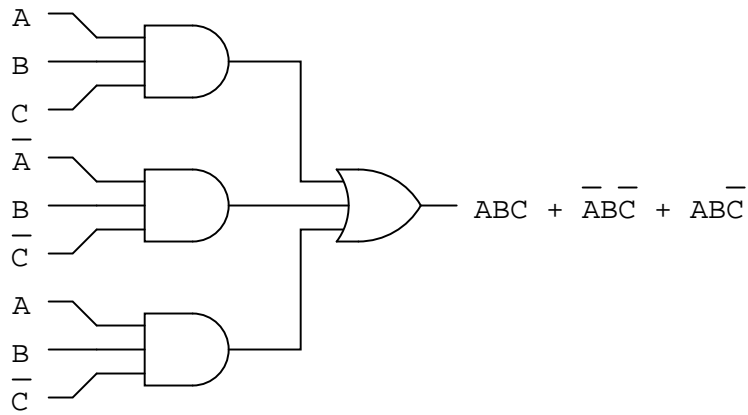
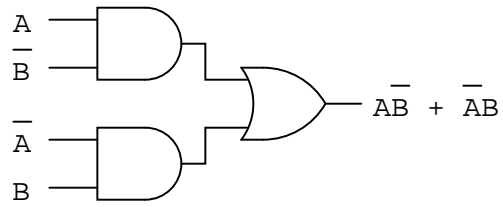
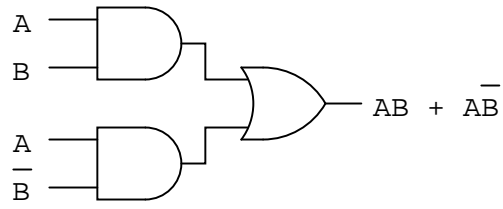

The output of this circuit is high when \bar{A} is true and \bar{B} is true, or when A is true and B is true:

$$(\bar{A} \text{ AND } \bar{B}) \text{ OR } (A \text{ AND } B)$$

Answer 46

For the first truth table: the output of this circuit is high when A is true and \bar{B} is true and C is true:

$$A \text{ AND } \bar{B} \text{ AND } C$$

For the second truth table: the output of this circuit is high when \bar{A} is true and \bar{B} is true and C is true, or when \bar{A} is true and B is true and \bar{C} is true:

$$(\bar{A} \text{ AND } \bar{B} \text{ AND } C) \text{ OR } (\bar{A} \text{ AND } B \text{ AND } \bar{C})$$

Follow-up question: do you suspect we could write a formal Boolean expression for each of these truth tables? What would those expressions be, and what form would they be in (SOP or POS)?

Answer 47

To make things easier, I'll associate each of the switches with a unique alphabetical letter:

- SW1 = A
- SW2 = B
- SW3 = C
- SW4 = D

Now, the Boolean expression:

$$A\bar{B}\bar{C}D$$

Answer 48

Original SOP expression:

$$\bar{A}B\bar{C} + A\bar{B}\bar{C}$$

Simplified expression and gate circuit:

$$B\bar{C}$$

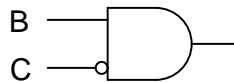

Original SOP expression and gate circuit:

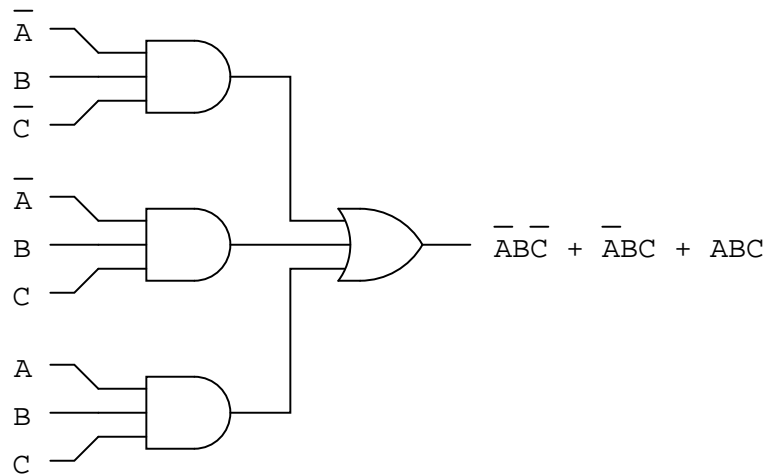

Reduced expression and gate circuit:

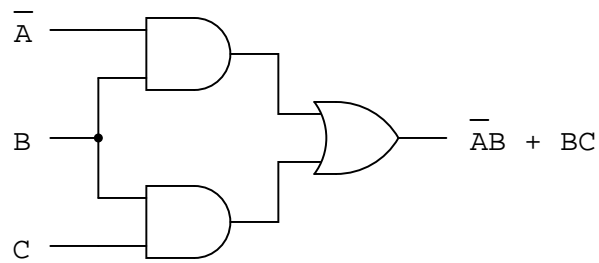

Original SOP expression and relay circuit:

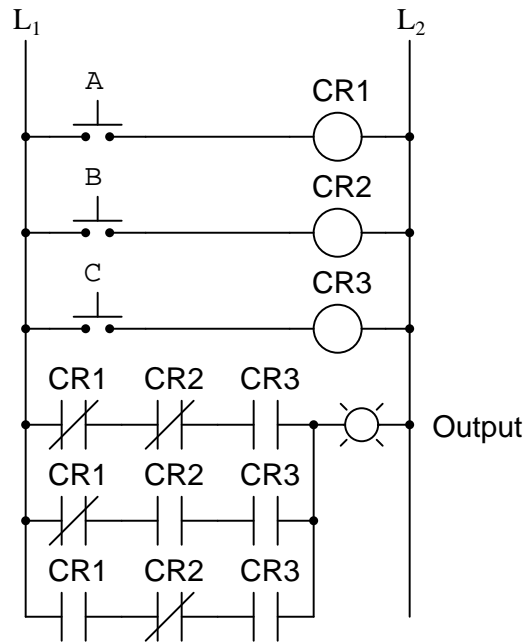

Reduced expression and relay circuit:

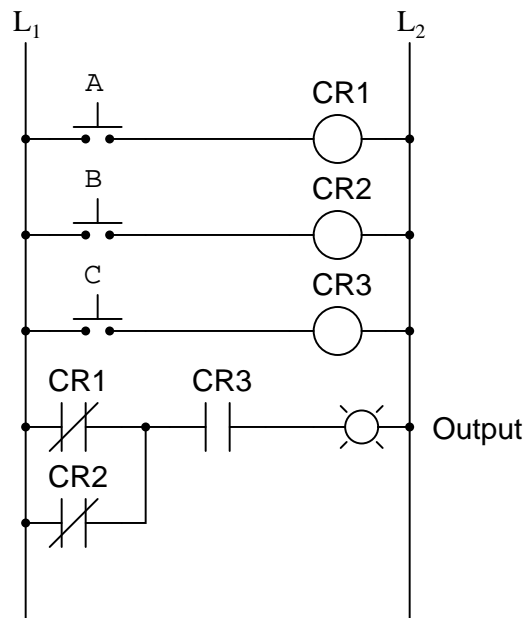

Answer 51

Simplest relay circuit possible:

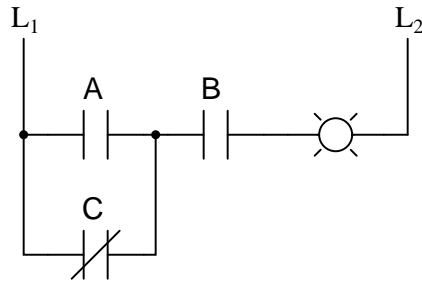

Answer 52

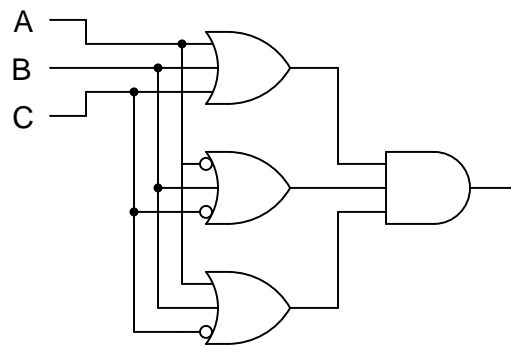
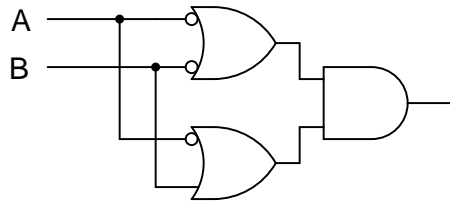
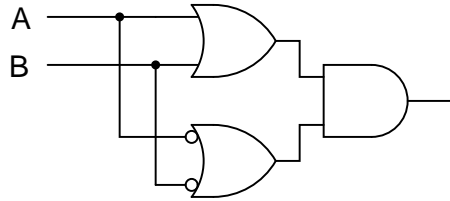

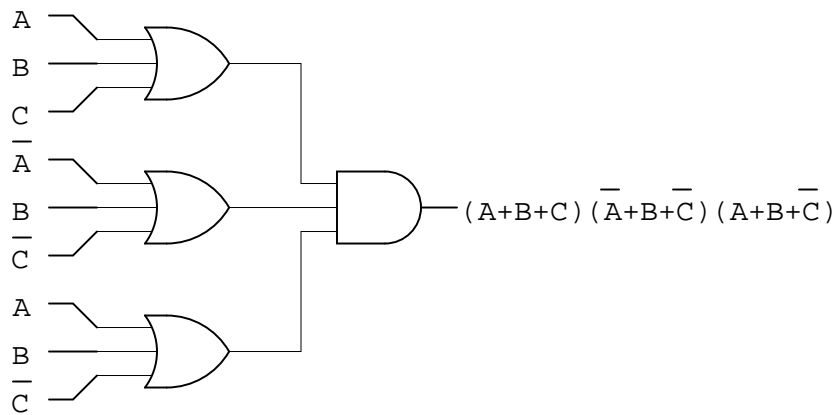
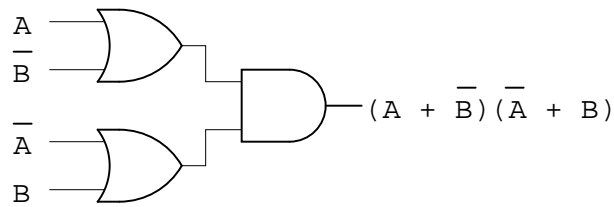
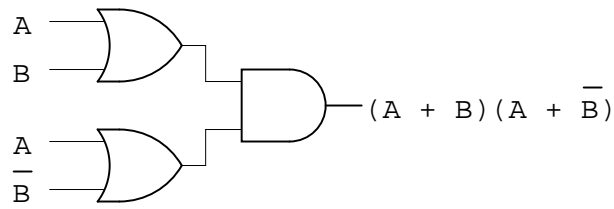

At least one of the sum terms must be equal to zero.

Follow-up question: in order for one of these terms to be equal to zero, thus making the whole expression equal to zero, what must be true about each of the Boolean literals (a *literal* is either a variable or the complement of a variable) within at least one of the sum terms?

Answer 55

Boolean expression for second gate circuit:

$$(\bar{A} + B)(\bar{A} + \bar{B})$$

Challenge question: we know that \overline{AB} is also a valid Boolean expression for the first gate (NAND) circuit, in addition to $\bar{A} + \bar{B}$. Is there a rule you can think of to derive \overline{AB} directly from an inspection of the truth table? Can you apply this rule to the second gate circuit and then manipulate the resulting expression using Boolean laws and rules to obtain the expression $(\bar{A} + B)(\bar{A} + \bar{B})$?

Answer 56

SOP expression:

$$\bar{A}\bar{B}\bar{C} + \bar{A}B\bar{C} + A\bar{B}\bar{C} + ABC\bar{C}$$

POS expression:

$$(A + B + \bar{C})(A + \bar{B} + \bar{C})(\bar{A} + B + C)(\bar{A} + \bar{B} + \bar{C})$$

Note: before deciding which expression is simpler, remember that the POS expression must be distributed before we may apply any of the standard Boolean simplification rules.

Follow-up question: compare and contrast the procedures for generating SOP versus POS expressions from a truth table. What states (1 or 0) are you looking for when writing each type of expression? Explain why.

Challenge question: what truth table scenarios do you suppose would "favor" an SOP expression over a POS expression, and visa-versa? In other words, under what conditions does a truth table yield a simpler SOP expression, versus a simpler POS expression?

Answer 57

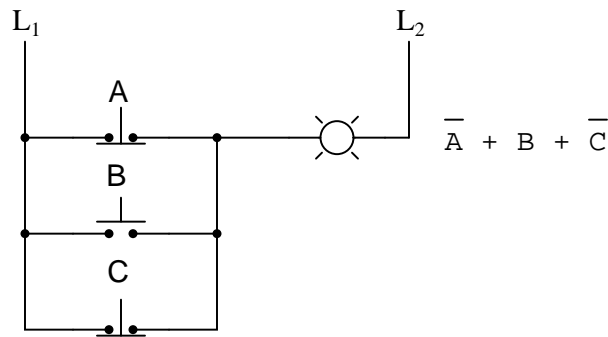

Answer 58

Original POS expression:

$$(A + \bar{B} + C)(\bar{A} + B + C)$$

Simplified expression and gate circuit:

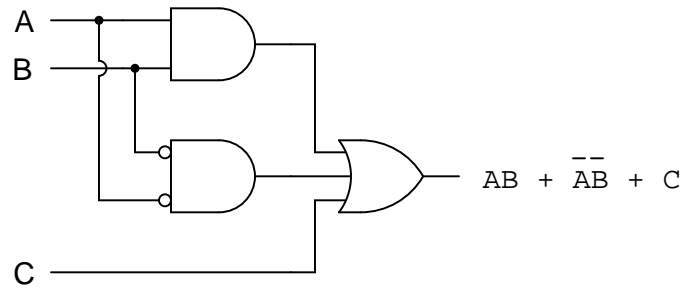

Answer 59

Original POS expression:

$$(\bar{A} + \bar{B} + C)(\bar{A} + \bar{B} + \bar{C})$$

Simplified gate circuit:

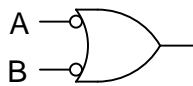

Challenge question: what other single gate type will satisfy the truth table (besides a Negative-OR gate)?

Answer 60

SOP form: $\bar{A}B + A\bar{B}$

POS form: $(\bar{A} + \bar{B})(A + B)$

I'll let you do the algebra showing these two expressions to be equivalent!

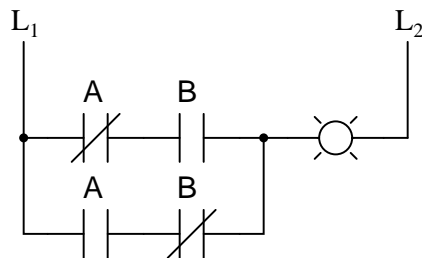

Answer 61

		C	
		0	1
AB	00	1	1
	01	0	1
	11	0	0
	10	0	1

Answer 62

		CD			
		00	01	11	10
AB	00	0	1	0	0
	01	0	1	0	0
	11	0	1	1	0
	10	0	1	1	1

Answer 63

For this cluster of four 1's, variables A and C are the only two inputs that change. Variables B and D remain the same ($B = 1$ and $D = 1$) for each of the four "high" outputs.

Answer 64

For this cluster of four 1's, variables A and B are the only two inputs that remain constant for the four "1" conditions shown in the Karnaugh map. The simplified Boolean expression for the truth table is AB . See a pattern here?

Answer 65

		CD			
		00	01	10	11
AB	00	0	0	0	0
	01	0	1	0	1
	10	0	0	0	0
	11	0	1	0	1

Looking at this, we can still tell that $B = 1$ and $D = 1$ for all four "high" output conditions, but this is *not* apparent by proximity as it was before.

Answer 66

CD \ AB	00	01	11	10	00	01	11	10
00	1	0	0	1	1	0	0	1
01	0	0	0	0	0	0	0	0
11	0	0	0	0	0	0	0	0
10	1	0	0	1	1	0	0	1
00	1	0	0	1	1	0	0	1
01	0	0	0	0	0	0	0	0
11	0	0	0	0	0	0	0	0
10	1	0	0	1	1	0	0	1

Follow-up question: what does this problem tell us about grouping? In other words, how can we identify groups of "high" states without having to make oversized Karnaugh maps?

Answer 67

Proper grouping of 1's in the Karnaugh map:

AB \ C	0	1
00	0	0
01	0	1
11	0	1
10	0	1

BC

AC

Answer 68

Any good introductory digital textbook will give the rules you need to do Karnaugh mapping. I leave you to research these rules for yourself!

Answer 69

Karnaugh map groupings with strict "1" groups:

$$\overline{D}B + \overline{D}CA + D\overline{C}\overline{B} + \overline{C}\overline{B}\overline{A}$$

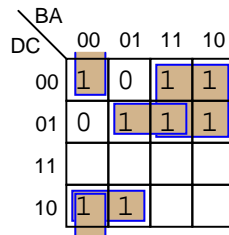

Karnaugh map groupings with "don't care" wildcards:

$$D + B + CA + \overline{C}\overline{A}$$

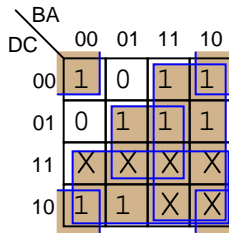

Follow-up question: this question and answer merely focused on the *a* output for the BCD-to-7-segment decoder circuit. Imagine if we were to approach all seven outputs of the decoder circuit in these two fashions, first developing SOP expressions using strict groupings of "1" outputs, and then using "don't care" wildcards. Which of these two approaches do you suppose would yield the simplest gate circuitry overall? What impact would the two different solutions have on the decoder circuit's behavior for the six unspecified input combinations 1010, 1011, 1100, 1101, 1110, and 1111?

Answer 70

Yes, you can use Karnaugh maps to generate POS expressions, not just SOP expressions!

Answer 71

Simple expression and relay circuit:

$$B\overline{C}$$

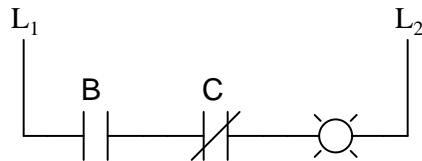

Answer 72

Simple expression and gate circuit:

$$AC + B\bar{C}\bar{D}$$

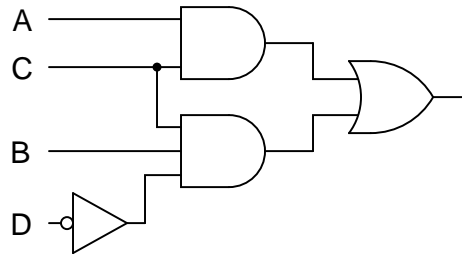

Challenge question: use Boolean algebra techniques to simplify the table's raw SOP expression into minimal form without the use of a Karnaugh map.

Answer 73

Simple expression and gate circuit:

$$AC + A\bar{B}\bar{D}$$

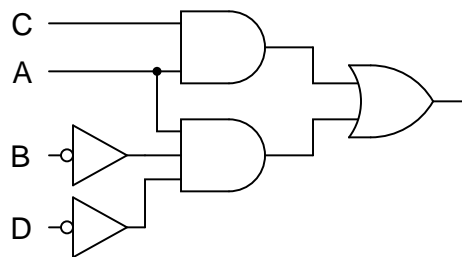

Challenge question: use Boolean algebra techniques to simplify the table's raw SOP expression into minimal form without the use of a Karnaugh map.

Answer 74

Simple expression and relay circuit:

$$B\bar{D} + \bar{C}D$$

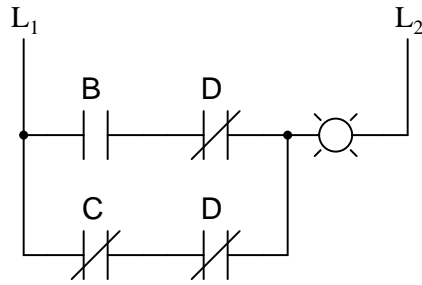

Follow-up question: although the relay circuit shown above does satisfy the minimal SOP Boolean expression, there is a way to make it simpler yet. Hint: done properly, you may eliminate one of the contacts in the circuit!

Challenge question: use Boolean algebra techniques to simplify the table's raw SOP expression into minimal form without the use of a Karnaugh map.

Answer 75

Simple expression and relay circuit:

$$B + \bar{D}$$

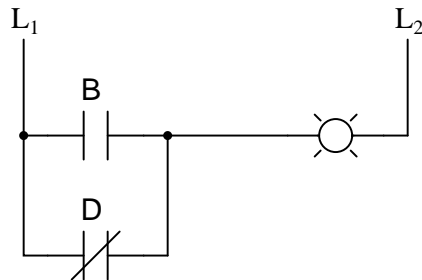

Answer 76

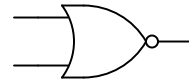
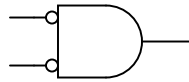

A	B	Output
0	0	1
0	1	0
1	0	0
1	1	0

A	B	Output
0	0	1
0	1	0
1	0	0
1	1	0

Negative-AND gate: $\overline{A \overline{B}}$

NOR gate: $\overline{A + B}$

Answer 77

Negative-AND gates have the same functionality as NOR gates, and their equivalent Boolean expression is as such:

$$\overline{A \overline{B}}$$

Negative-OR gates have the same functionality as NAND gates, and their equivalent Boolean expression is as such:

$$\overline{A + B}$$

Answer 78

DeMorgan's Theorem is a rule for Boolean expressions, declaring how long complementation "bars" are to be broken into shorter bars. I'll let you research the terms of this rule, and explain how to apply it to Boolean expressions.

Answer 79

Simplified expression:

$$ABC$$

Answer 80

Simplified expression:

$$\overline{Y} + X\overline{Z}$$

Answer 81

Simplified expression:

(Expression is always equal to 1)

Answer 82

(Output is always in a "low" state!)

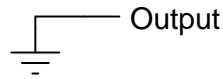

Answer 83

Original Boolean expression: $\overline{AB} + C$

Reduced circuit (no relays needed!):

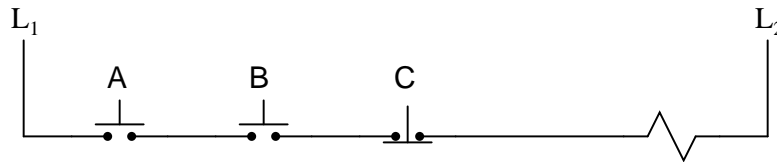

Answer 84

Original Boolean expression: $A + \overline{ABC}$

Reduced gate circuit:

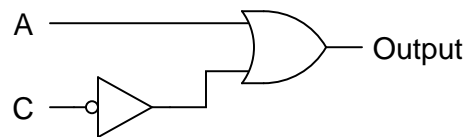

Challenge question: implement this reduced circuit, using the only remaining gates between the two integrated circuits shown on the original breadboard.

Answer 85

The correct answer is:

$$(X + \overline{Y})\overline{Z}$$

or

$$X\overline{Z} + \overline{Y}\overline{Z}$$

If it is not apparent to you why the student's steps are in error, try this exercise: draw the equivalent gate circuit for each of the expressions written in the student's work. At the mistaken step, a dramatic change in the circuit configuration will be evident – a change that clearly cannot be correct. If all steps are proper, though, changes exhibited in the equivalent gate circuits should all make sense, culminating in a final (simplified) circuit.

Answer 86

Original Boolean expression: $\overline{AB + AC}$

Reduced gate circuit:

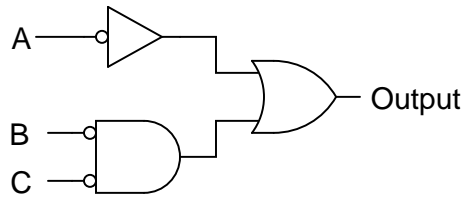

Answer 87

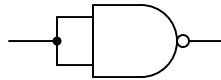

For the above solution: $\overline{AA} = \overline{A}$

Follow-up question: are there any other ways to use a NAND gate as an inverter? The method shown above is not the only valid solution!

Answer 88

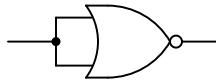

For the above solution: $\overline{A + A} = \overline{A}$

Follow-up question: are there any other ways to use a NOR gate as an inverter? The method shown above is not the only valid solution!

Answer 89

This is a lot like algebraically manipulating equations: doing the exact same thing to both sides of an equation to arrive at a new equation that is more useful to us. I'll let you figure out the details of how this is done.

Answer 90

I'll let you figure this one out on your own!

Answer 91

Using nothing but NAND gates:

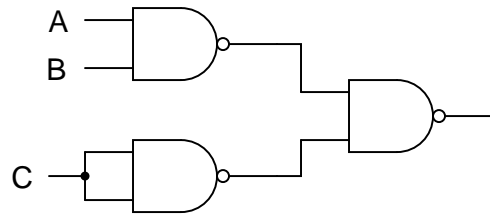

Using nothing but NOR gates:

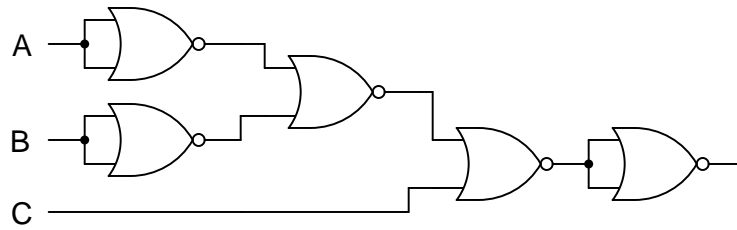

Answer 92

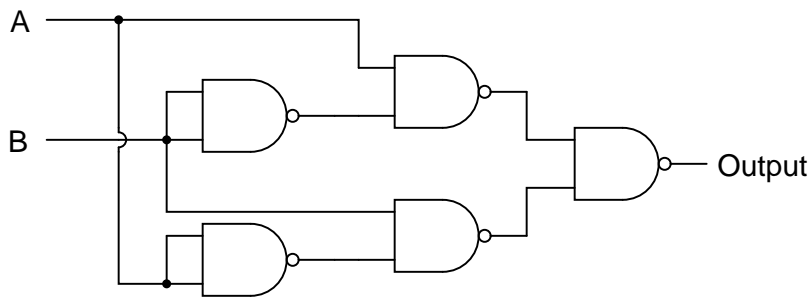

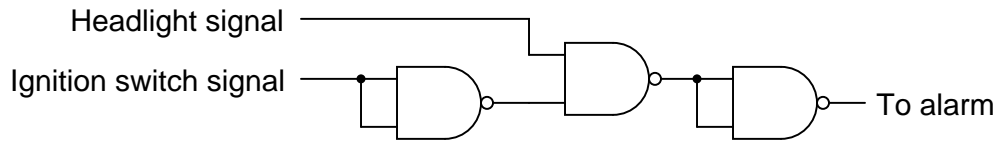

Follow-up question: suppose the alarm unit required more current than the final NAND gate could source. Add a transistor "buffer" stage to the logic gate circuit to drive additional current to the alarm.

Challenge question: explain how the following NOR gate circuit performs the exact same logic function with fewer components:

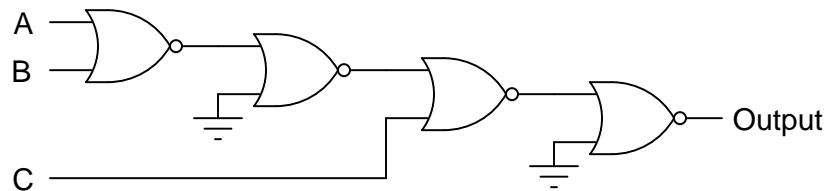
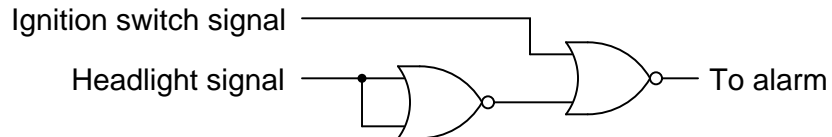

Follow-up question: note the manner in which NOR gates are used as inverters in this circuit. Compare this against the following (alternative) method:

NOR gate as inverter

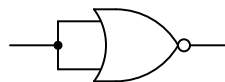

Are there any distinct advantages you see to either method?

Answer 95

Original circuit expression:

$$\overline{\overline{A} \overline{B} \overline{C} \overline{D} \overline{E}}$$

Simplified expression and circuit:

$$A + B + C + D + E$$

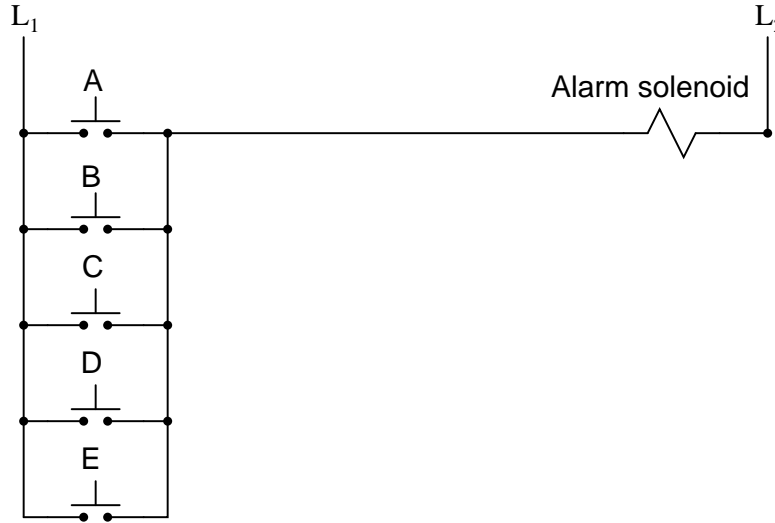

Follow-up question: which circuit (the original or the one show above) is more practical from a fail-safe standpoint? In other words, which circuit will give the *safest* result in the event of a switch or wiring failure?

Answer 96

Use circuit simulation software to verify your predicted and actual truth tables.

Answer 97

Use circuit simulation software to verify your predicted and actual truth tables.

Answer 98

Use circuit simulation software to verify your predicted and actual truth tables.

Answer 99

Be sure you meet with your instructor if you have any questions about what is expected for your project!

Answer 100

- Any low input guarantees a high output: **NAND** gate.
- Any high input guarantees a low output: **NOR** gate.
- Any high input guarantees a high output: **OR** gate.
- Any difference in the inputs guarantees a high output: **XOR** gate.
- Any difference in the inputs guarantees a low output: **XNOR** gate.

Answer 101

- $B = A$ when Control is high: **AND** gate and **XNOR** gate.
- $B = A$ when Control is low: **OR** gate and **XOR** gate.
- $B = \bar{A}$ when Control is high: **NAND** gate and **XOR** gate.
- $B = \bar{A}$ when Control is low: **NOR** gate and **XNOR** gate.

Follow-up question: explain why XOR and XNOR gates are so useful as signal controllers.

Answer 102

- Output of OR gate U_2 fails low: *Gate U_4 output stuck in the low state.*
 - Output of inverter gate U_3 fails low: *Gate U_4 output stuck in the low state.*
 - Output of AND gate U_1 fails high: *Gate U_4 output simply equal to \bar{D} , no other inputs have any effect on U_4 's output.*
-

Answer 103

- Output of AND gate U_2 fails low: *Gate U_3 output stuck in the high state.*
 - Output of AND gate U_2 fails high: *Gate U_3 output simply equal to \bar{C} , no other inputs have any effect on U_3 's output.*
 - Output of inverter gate U_1 fails low: *Gate U_3 output stuck in the high state.*
-

Answer 104

- Output of NAND gate U_2 fails low: *Gate U_4 output stuck in the low state.*
 - Output of buffer gate U_3 fails low: *Gate U_4 output stuck in the low state.*
 - Output of NOR gate U_1 fails high: *Gate U_4 output simply equal to $\bar{C}D$, no other inputs have any effect on U_4 's output.*
-

Answer 105

- Pushbutton switch A fails open: *Lamp 1 always energized, lamp 2 simply becomes inverse status of pushbutton switch B.*
- Relay coil CR2 fails open: *Both lamp 1 and lamp 2 simply become inverse status of pushbutton switch A.*
- Relay contact CR1-1 fails open: *Lamp 1 simply becomes same status as pushbutton switch B.*
- Relay contact CR2-1 fails shorted: *Lamp 1 always energized.*
- Relay contact CR2-2 fails shorted: *Lamp 2 simply becomes inverse status of pushbutton switch A.*

Answer 106

- Comparator U_1 output fails low: *Lamp energizes when $V_{in} > V_{ref(low)}$, even if $V_{in} > V_{ref(high)}$.*
- Comparator U_1 output fails high: *Lamp energizes only when $V_{in} < V_{ref(low)}$.*
- Comparator U_2 output fails low: *Lamp energizes only when $V_{in} > V_{ref(high)}$.*
- Comparator U_2 output fails high: *Lamp energizes when $V_{in} < V_{ref(high)}$, even if $V_{in} < V_{ref(low)}$.*
- Wire connecting V_{DD} to R_{pot1} fails open: *Lamp refuses to energize.*

Answer 107

U_3 and Q_1 are the most suspect components, given the behavior of the circuit. I'll let you figure out what to measure next!

Answer 108

The AND gate may be bad, or it may be good. The test as described is inconclusive.

Follow-up question: what would have to be checked to make the described test procedure valid?

Answer 109

This is a problem worthy of a good in-class discussion with your peers! Of course, several things could be wrong in this circuit to cause lamp 1 to never energize. When you explain what measurements you would take in isolating the problem, be sure to describe whether or not you are actuating either of the pushbutton switches when you take those measurements.

Answer 110

When factoring, you must look for variables *common* to each product term.

Follow-up question: if implemented with digital logic gates, which of these two expressions would require the fewest components?

$$A(B + C)$$

$$AB + AC$$

Answer 111

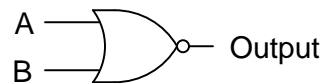

Answer 112

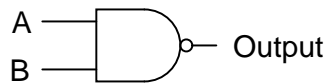

Answer 113

I'll leave the proof up to you!

Answer 114

Original Boolean expression: $\overline{AB} \overline{BC}$

Reduced gate circuit:

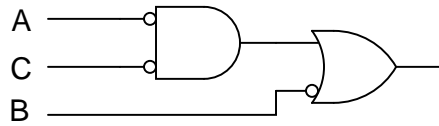

Answer 115

Original Boolean expression: $\overline{\overline{ABC}A}$

Reduced gate circuit:

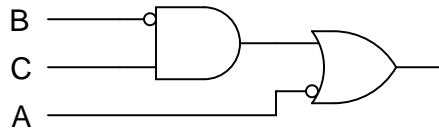

Answer 116

Raw (unsimplified) expressions:

$$a = (D + C + B + \overline{A})(D + \overline{C} + B + A)$$

$$b = (D + \overline{C} + B + \overline{A})(D + \overline{C} + \overline{B} + A)$$

$$c = D + C + \overline{B} + A$$

$$e = \overline{D} \overline{C} \overline{B} \overline{A} + \overline{D} \overline{C} B \overline{A} + \overline{D} C B \overline{A} + D \overline{C} \overline{B} \overline{A}$$

Challenge question: use the laws of Boolean algebra to simplify each of the above expressions into their simplest forms.

Notes 1

In order to familiarize students with the standard logic gate types, I like to give them practice with identification and truth tables each day. Students need to be able to recognize these logic gate types at a glance, or else they will have difficulty analyzing circuits that use them.

Notes 2

In order to familiarize students with standard switch contact configurations, I like to give them practice with identification and truth tables each day. Students need to be able to recognize these ladder logic sub-circuits at a glance, or else they will have difficulty analyzing more complex relay circuits that use them.

Notes 3

Some students with background in computers may ask if Boolean is the same as binary. The answer to this very good question is "no." Binary is simply a *numeration system* for expressing real numbers, while Boolean is a completely different number system (like integer numbers are to irrational numbers, for example). It is possible to count arbitrarily high in binary, but you can only count as high as "1" in Boolean.

Notes 4

Boolean algebra is a strange math, indeed. However, once students understand the limited scope of Boolean quantities, the rationale for Boolean rules of arithmetic make sense. $1 + 1$ *must* equal 1, because there is no such thing as "2" in the Boolean world, and the answer certainly can't be 0.

Notes 5

Students need to be able to readily associate fundamental Boolean operations with logic circuits. If they can see the relationship between the "strange" rules of Boolean arithmetic and something they are already familiar with (i.e. truth tables), the association is made much easier.

Notes 6

Students need to be able to readily associate fundamental Boolean operations with logic circuits. If they can see the relationship between the "strange" rules of Boolean arithmetic and something they are already familiar with (i.e. truth tables), the association is made much easier.

Notes 7

Students need to be able to readily associate fundamental Boolean operations with logic circuits. If they can see the relationship between the "strange" rules of Boolean arithmetic and something they are already familiar with (i.e. truth tables), the association is made much easier.

Notes 8

These three equivalencies will be vital for students to master as they study combinational logic circuits and complex relay logic circuits!

Notes 9

In order to familiarize students with Boolean algebra and how it relates to logic gate circuitry, I like to give them daily practice with questions such as this. Students need to be able to recognize these logic gate types at a glance, and also be able to associate the proper Boolean expression with each one, or else they will have difficulty analyzing logic circuits later on.

Notes 10

In order to familiarize students with Boolean algebra and how it relates to relay logic circuitry, I like to give them daily practice with questions such as this. Students need to be able to figure out how each one of these ladder logic circuits works, and also be able to associate the proper Boolean expression with each one, or else they will have difficulty analyzing more complex relay circuits later on.

Notes 11

The process of converting gate circuits into Boolean expressions is really quite simple, if you proceed gate by gate. Have your students share whatever methods or "tricks" they use to write the expressions with the rest of the class.

Notes 12

The process of converting gate circuits into Boolean expressions is really quite simple, if you proceed gate by gate. Have your students share whatever methods or "tricks" they use to write the expressions with the rest of the class.

Notes 13

The process of converting gate circuits into Boolean expressions is really quite simple, if you proceed gate by gate. Have your students share whatever methods or "tricks" they use to write the expressions with the rest of the class.

Notes 14

The process of converting relay logic circuits into Boolean expressions is not quite as simple as it is converting gate circuits into Boolean expressions, but it is manageable. Have your students share whatever methods or "tricks" they use to write the expressions with the rest of the class.

Notes 15

The process of converting relay logic circuits into Boolean expressions is not quite as simple as it is converting gate circuits into Boolean expressions, but it is manageable. Have your students share whatever methods or "tricks" they use to write the expressions with the rest of the class.

Notes 16

The process of converting relay logic circuits into Boolean expressions is not quite as simple as it is converting gate circuits into Boolean expressions, but it is manageable. Have your students share whatever methods or "tricks" they use to write the expressions with the rest of the class.

Notes 17

This is not a very complicated function to express or implement, the point of this question being mostly to introduce students to a practical use of logic gates and Boolean algebra.

Notes 18

The process of converting Boolean expressions into logic gate circuits is not quite as simple as converting gate circuits into Boolean expressions, but it is manageable. Have your students share whatever methods or "tricks" they use to write the expressions with the rest of the class.

Notes 19

To be honest, I had fun writing the scenarios for different parts of this problem. The evolution of this alarm system is typical for an organization. Someone comes up with an idea, but it doesn't meet all the needs of someone else, so they input their own suggestions, and so on, and so on. Presenting scenarios such as this not only prepare students for the politics of real work, but also underscore the need to "what if?" thinking: to test the proposed solution before implementing it, so that unnecessary problems are avoided.

Notes 20

First things first: did students remember to include the power supply connections to each IC? This is a very common mistake!

In order to successfully develop a solution to this problem, of course, students must research the "pinouts" of each integrated circuit. If most students simply present the answer shown to them in the worksheet, challenge them during discussion to present alternative solutions.

Also, ask them this question: "should we connect the unused inputs to either ground or V_{CC} , or is it permissible to leave the inputs floating?" Students should not just give an answer to this question, but be able to support their answer(s) with reasoning based on the construction of this type of logic circuit.

Notes 21

Ask your students to explain exactly how they figured out the "Output" states to fill in the blanks in the truth tables, for the different input combinations. Ask them also to compare and contrast this process with that of figuring out the truth table for a given logic gate circuit.

Notes 22

Ask your students to explain exactly how they figured out the "Output" states to fill in the blanks in the truth tables, for the different input combinations. Ask them also to compare and contrast this process with that of figuring out the truth table for a given logic gate circuit.

It is especially educational if you ask your students to suggest techniques for *quickly* determining truth table states, based on certain features of the Boolean expression. For instance, there is a way we can tell the first four "Output" states in the truth table (reading top to bottom) will be 0 without having to plug values into the expression for B and C. Discuss with your students how we can look at the expression, seeing A as a multiplier for the sum within the parentheses, and immediately conclude that half of the truth table outputs will be 0.

Notes 23

The commutative, associative, and distributive laws of Boolean algebra are identical to the respective laws in real number algebra. These should not be difficult concepts for your students to understand. The real benefit of working through these examples is to associate gate and relay logic circuits with Boolean expressions, and to see that Boolean algebra is nothing more than a symbolic means of representing electrical discrete-state (on/off) circuits. In relating otherwise abstract mathematical concepts to something tangible, students build a much better comprehension of the concepts.

Notes 24

Most of these Boolean rules are identical to their respective laws in real number algebra. These should not be difficult concepts for your students to understand. Some of them, however, are unique to Boolean algebra, having no analogue in real-number algebra. These unique rules cause students the most trouble!

An important benefit of working through these examples is to associate gate and relay logic circuits with Boolean expressions, and to see that Boolean algebra is nothing more than a symbolic means of representing electrical discrete-state (on/off) circuits. In relating otherwise abstract mathematical concepts to something tangible, students build a much better comprehension of the concepts.

Notes 25

Quite frequently (and quite distressingly), I meet students who seem to have the most difficult time relating algebraic rules in their general form to specific instances of reduction. For example, a student who cannot tell that the rule $A + AB = A$ applies to the expression $QR + R$, or worse yet $B + AB$. This skill requires time and hard work to master, because it is fundamentally a matter of abstraction: leaping from literal expressions to *similar* expressions, applying patterns from general rules to specific instances.

Questions such as this help students develop this abstraction ability. Let students explain how they "made the connection" between Boolean rules and the given reductions. Often, it helps to have a student explain the process to another student, because they are better able than you to put it into terms the struggling students can understand.

Notes 26

Quite frequently (and quite distressingly), I meet students who seem to have the most difficult time relating algebraic rules in their general form to specific instances of reduction. For example, a student who cannot tell that the rule $A + AB = A$ applies to the expression $QR + R$, or worse yet $B + AB$. This skill requires time and hard work to master, because it is fundamentally a matter of abstraction: leaping from literal expressions to *similar* expressions, applying patterns from general rules to specific instances.

Questions such as this help students develop this abstraction ability. Let students explain how they "made the connection" between Boolean rules and the given reductions. Often, it helps to have a student explain the process to another student, because they are better able than you to put it into terms the struggling students can understand.

Notes 27

An interesting way to sharpen students' understanding of algebraic techniques is to have them view someone else's incorrect work and find the error(s). Ultimately, algebraic reduction is really just an exercise in pattern recognition. Anything you can do to help your students recognize the correct patterns will help them become better at using algebra.

Notes 28

For some reason, many of my students (who enter my course weak in algebra skills) generally seem to have a lot of trouble with factoring, be it Boolean algebra or regular algebra. This is unfortunate, as factoring is a powerful analytical tool. The "trick," if there is any such thing, is recognizing common variables in different product terms, and identifying which of them should be factored out to reduce the expression most efficiently.

Like all challenging things, factoring takes time and practice to learn. There are no shortcuts, really.

Notes 29

Quite frequently (and quite distressingly), I meet students who seem to have the most difficult time relating algebraic rules in their general form to specific instances of reduction. For example, a student who cannot tell that the rule $A + AB = A$ applies to the expression $QR + R$, or worse yet $B + AB$. This skill requires time and hard work to master, because it is fundamentally a matter of abstraction: leaping from literal expressions to *similar* expressions, applying patterns from general rules to specific instances.

Questions such as this help students develop this abstraction ability. Let students explain how they "made the connection" between Boolean rules and the given reductions. Often, it helps to have a student explain the process to another student, because they are better able than you to put it into terms the struggling students can understand.

Notes 30

Many students find the substitution of Boolean variables (going from the A's and B's of canonical rules to the different variables of real expressions where the rules are to be applied) very mysterious and difficult. Problems such as this give them practice learning to identify the rules' *patterns* despite similarities or differences in the actual variables (letters) used.

Notes 31

Have your students explain the entire process they used in answering this question: simplifying the expression using Boolean algebra techniques, and developing a gate circuit from the simplified Boolean expression. By having your students share their thought processes with the whole class, you will increase the level of learning on the parts of presenter and viewer alike. Students presenting their solutions will gain a better understanding of how it works because the act of presenting helps consolidate what they already know. Students viewing the presentation will get to see another person's technique (rather than just the instructor's), which will allow them to see examples of how to do these processes cast in slightly different terms.

Notes 32

Have your students explain the entire process they used in answering this question: simplifying the expression using Boolean algebra techniques, and developing a gate circuit from the simplified Boolean expression. By having your students share their thought processes with the whole class, you will increase the level of learning on the parts of presenter and viewer alike. Students presenting their solutions will gain a better understanding of how it works because the act of presenting helps consolidate what they already know. Students viewing the presentation will get to see another person's technique (rather than just the instructor's), which will allow them to see examples of how to do these processes cast in slightly different terms.

Notes 33

Have your students explain the entire process they used in answering this question: simplifying the expression using Boolean algebra techniques, and developing a gate circuit from the simplified Boolean expression. By having your students share their thought processes with the whole class, you will increase the level of learning on the parts of presenter and viewer alike. Students presenting their solutions will gain a better understanding of how it works because the act of presenting helps consolidate what they already know. Students viewing the presentation will get to see another person's technique (rather than just the instructor's), which will allow them to see examples of how to do these processes cast in slightly different terms.

Notes 34

Have your students explain the entire process they used in simplifying the gate circuit: developing the Boolean expression, simplifying that expression using Boolean algebra techniques, and then developing a new gate circuit from the simplified Boolean expression. By having your students share their thought processes with the whole class, you will increase the level of learning on the parts of presenter and viewer alike. Students presenting their solutions will gain a better understanding of how it works because the act of presenting helps consolidate what they already know. Students viewing the presentation will get to see another person's technique (rather than just the instructor's), which will allow them to see examples of how to do these processes cast in slightly different terms.

Notes 35

Have your students explain the entire process they used in simplifying the gate circuit: developing the Boolean expression, simplifying that expression using Boolean algebra techniques, and then developing a new gate circuit from the simplified Boolean expression. By having your students share their thought processes with the whole class, you will increase the level of learning on the parts of presenter and viewer alike. Students presenting their solutions will gain a better understanding of how it works because the act of presenting helps consolidate what they already know. Students viewing the presentation will get to see another person's technique (rather than just the instructor's), which will allow them to see examples of how to do these processes cast in slightly different terms.

Notes 36

Have your students explain the entire process they used in simplifying the gate circuit: developing the Boolean expression, simplifying that expression using Boolean algebra techniques, and then developing a new gate circuit from the simplified Boolean expression. By having your students share their thought processes with the whole class, you will increase the level of learning on the parts of presenter and viewer alike. Students presenting their solutions will gain a better understanding of how it works because the act of presenting helps consolidate what they already know. Students viewing the presentation will get to see another person's technique (rather than just the instructor's), which will allow them to see examples of how to do these processes cast in slightly different terms.

Notes 37

Have your students explain the entire process they used in simplifying the relay circuit: developing the Boolean expression, simplifying that expression using Boolean algebra techniques, and then developing a new relay circuit from the simplified Boolean expression. By having your students share their thought processes with the whole class, you will increase the level of learning on the parts of presenter and viewer alike. Students presenting their solutions will gain a better understanding of how it works because the act of presenting helps consolidate what they already know. Students viewing the presentation will get to see another person's technique (rather than just the instructor's), which will allow them to see examples of how to do these processes cast in slightly different terms.

Notes 38

Have your students explain the entire process they used in simplifying the relay circuit: developing the Boolean expression, simplifying that expression using Boolean algebra techniques, and then developing a new relay circuit from the simplified Boolean expression. By having your students share their thought processes with the whole class, you will increase the level of learning on the parts of presenter and viewer alike. Students presenting their solutions will gain a better understanding of how it works because the act of presenting helps consolidate what they already know. Students viewing the presentation will get to see another person's technique (rather than just the instructor's), which will allow them to see examples of how to do these processes cast in slightly different terms.

Notes 39

Have your students explain the entire process they used in simplifying the relay circuit: developing the Boolean expression, simplifying that expression using Boolean algebra techniques, and then developing a new relay circuit from the simplified Boolean expression. By having your students share their thought processes with the whole class, you will increase the level of learning on the parts of presenter and viewer alike. Students presenting their solutions will gain a better understanding of how it works because the act of presenting helps consolidate what they already know. Students viewing the presentation will get to see another person's technique (rather than just the instructor's), which will allow them to see examples of how to do these processes cast in slightly different terms.

Notes 40

Have your students explain the entire process they used in simplifying the relay circuit: developing the Boolean expression, simplifying that expression using Boolean algebra techniques, and then developing a new relay circuit from the simplified Boolean expression. By having your students share their thought processes with the whole class, you will increase the level of learning on the parts of presenter and viewer alike. Students presenting their solutions will gain a better understanding of how it works because the act of presenting helps consolidate what they already know. Students viewing the presentation will get to see another person's technique (rather than just the instructor's), which will allow them to see examples of how to do these processes cast in slightly different terms.

Notes 41

In order to familiarize students with the standard logic gate types, I like to give them practice with identification and truth tables each day. Students need to be able to recognize these logic gate types at a glance, or else they will have difficulty analyzing circuits that use them.

Notes 42

In order to familiarize students with standard switch contact configurations, I like to give them practice with identification and truth tables each day. Students need to be able to recognize these ladder logic sub-circuits at a glance, or else they will have difficulty analyzing more complex relay circuits that use them.

Notes 43

Even if your students have never heard of Boolean algebra before, they should still be able to determine which of the first four expressions are SOP and which are POS. If there is any confusion on this point, ask your students to define what "sum" and "product" mean, respectively, and then discuss what it means for an expression to be a product (singular) of sums (multiple), or a sum (singular) of products (multiple).

Notes 44

The translation from Boolean SOP to gate circuit should not be difficult. The point of this question is to get students thinking in terms of sum-of-products form, so they will be ready for the next step: linking this concept with truth tables.

Notes 45

Expressing truth table conditions "verbally" is a way to introduce students to the concept of deriving Boolean expression from them.

Notes 46

I find this "verbal" approach works well to introduce students to the concept of deriving Boolean expressions from truth tables.

Be sure to ask your students what Boolean expressions they derived for both these truth tables. Given the answers in "verbal" form, this should not be difficult for them!

Notes 47

This problem gives students a preview of *sum-of-products* notation. By examining the truth table, they should be able to determine that only one combination of switch settings (Boolean values) provides a "1" output, and with a little thought they should be able to piece together this Boolean product statement.

Though this question may be advanced for some students (especially those weak in mathematical reasoning skills), it is educational for all in the context of classroom discussion, where the thoughts of students and instructor alike are exposed.

Notes 48

Challenge your students to implement the original SOP expression directly with logic gates (three-input gates are acceptable to use).

Notes 49

Discuss with your students the utility of Boolean algebra as a circuit simplification tool. Ask your students to compare the original and reduced logic gate circuits, and comment on such performance metrics as reliability, power consumption, maximum operating speed, etc.

Notes 50

Discuss with your students the utility of Boolean algebra as a circuit simplification tool. Ask your students to compare the original and reduced logic gate circuits, and comment on such performance metrics as reliability, power consumption, maximum operating speed, etc.

Notes 51

Ask your students to show all their work in designing the relay circuit. By presenting their thought processes, not only do you help them consolidate their learning, but you also help the other students understand better by allowing them to learn from a peer.

Notes 52

The translation from Boolean POS to gate circuit should not be difficult. The point of this question is to get students thinking in terms of product-of-sums form, so they will be ready for the next step: linking this concept with truth tables.

Notes 53

The translation from Boolean POS to gate circuit should not be difficult. The point of this question is to get students thinking in terms of sum-of-products form, so they will be ready for the next step: linking this concept with truth tables.

Notes 54

This question foreshadows the derivation of POS expressions from truth tables. It also parallels the subject of polynomial roots in real-number algebra. For instance, the polynomial $x^2 - 2x - 8$ may be factored as such:

$$(x - 4)(x + 2)$$

If we were to set this equation equal to zero, the *roots* of the equation would be 4 and -2: the values for x which would make either one of the terms equal to zero.

You may find this mini-review of "normal" algebra to be helpful to your students, as they try to understand POS expressions.

Notes 55

The purpose of this question, if it isn't obvious to you by now, is to have students "discover" the technique for deriving POS expressions from truth tables, based on an evaluation of all the "low" output states.

Your more advanced students should enjoy the challenge question, for it allows one to generate Boolean expressions using a rule more similar to the first one learned: table-to-SOP.

Notes 56

This question is really asking students to compare and contrast SOP against POS expressions, rather than being a question specific to the given truth table. The actual expressions given in the answer are there only for "drill," so students may check their work. The *real* answers relate to the follow-up and challenge questions!

Notes 57

Ask students to contrast the difficulty of writing a POS expression for this function, versus an SOP expression. The difference in complexity is great! Also, ask them to compare the circuitry equivalent to each form of Boolean expression for this truth table. Which form yields a circuit with fewer gates?

Notes 58

Challenge your students to implement the original POS expression directly with logic gates (three-input gates are acceptable to use). Is the "simplified" POS expression shown in the answer really simpler in the context of real gate circuits? Ask your students what lesson this comparison holds for Boolean simplification techniques and their application to real-world circuits.

Notes 59

Challenge your students to implement the original POS expression directly with logic gates (three-input gates are acceptable to use). Is the "simplified" POS expression shown in the answer simpler in the context of real gate circuits? Ask your students what lesson this comparison holds for Boolean simplification techniques and their application to real-world circuits.

Notes 60

Ask your students how many of them used a truth table to solve this problem. This is a helpful hint, as a truth table for an Ex-OR gate is easy to remember (or look up), and it provides a basis for easily constructing an SOP or POS expression.

The Exclusive-OR function is very, very useful in logic circuits. It is well worth students' time to understand how to represent it in Boolean form (and no, not using that funny \oplus symbol, either, but representing it in a form where all the standard laws of Boolean algebra apply!).

Notes 61

Showing students that Karnaugh maps are really nothing more than truth tables in disguise helps them to more readily learn this powerful new tool.

Notes 62

Showing students that Karnaugh maps are really nothing more than truth tables in disguise helps them to more readily learn this powerful new tool.

Notes 63

This question introduces students to the Karnaugh reduction principle of detecting *contradictory variables* in a grouped set.

Notes 64

This question strongly suggests to students that the Karnaugh map is a graphical method of achieving a reduced-form SOP expression for a truth table. Once students realize Karnaugh mapping holds the key to escaping arduous Boolean algebra simplifications, their interest will be piqued!

Notes 65

You could simply tell your students that the input variables must be sequenced according to Gray code in order for Karnaugh mapping to work as a simplification tool, but this wouldn't explain to students *why* it needs to be such. This question shows students the purpose of Gray code sequencing in Karnaugh maps, by showing them the alternative (binary sequencing), and allowing them to see how the task of seeking noncontradictory variables is complicated by it.

Notes 66

The concept of bit groups extending past the boundaries of a Karnaugh map tends to confuse students. In fact, it is about the only thing that tends to confuse students about Karnaugh maps! Simply telling them to group past the borders of the map doesn't really teach them *why* the technique is valid. Here, they should see with little difficulty why the technique works.

And, if for some reason they just can't visualize bit groups past the boundaries of a Karnaugh map, they know they can just draw an oversized map and it will become obvious!

Notes 67

The purpose of this question is to illustrate how it is incorrect to identify clusters of arbitrary size in a Karnaugh map. A cluster of three, as seen in this scenario, leads to an incorrect conclusion. Of course, one could easily quote a textbook as to the proper numbers and patterns of 1's to identify in a Karnaugh map, but it is so much more informative (in my opinion) to illustrate by example. Posing a dilemma such as this makes students *think* about why the answer is wrong, rather than asking them to remember seemingly arbitrary rules.

Notes 68

The answer speaks for itself here – let your students research these rules, and ask them exactly where they found them (including the page numbers in their textbook(s)!).

Notes 69

One of the points of this question is for students to realize that bigger groups are better, in that they yield simpler SOP terms. Also, students should realize that the ability to use "don't care" states as "wildcard" placeholders in the Karnaugh map cells increases the chances of creating bigger groups.

Truth be known, I chose a pretty bad example to try to make an SOP expression from, since there are only two non-zero output conditions out of ten! Formulating a POS expression would have been easier, but that's a subject for another question!

Notes 70

I am more interested in seeing students' approach to this problem than acknowledgment of the answer (that Karnaugh maps may be used to generate SOP and POS expressions alike). Setting up a Karnaugh map to see if a POS expression may be obtained for this truth table is not difficult to do, but many students are so unfamiliar/uncomfortable with "experimenting" in this manner than they tend to freeze when presented with a problem like this. Without specific instructions on what to do, the obvious steps of "try it and see" elude them.

It is your charge as their instructor to encourage an experimental mindset among your students. Do not simply tell them how to go about "discovering" the answer on their own, for if you do you will rob them of an authentic discovery experience.

Notes 71

One of the things you may want to have your students share in front of the class is their Karnaugh maps, and how they grouped common output states to arrive at Boolean expression terms. I have found that an overhead (acetate) or computer-projected image of a blank Karnaugh map on a whiteboard serves well to present Karnaugh maps on. This way, cell entries may be easily erased and re-drawn without having to re-draw the map (grid lines) itself.

Ask your students to compare using a Karnaugh map versus using standard SOP/Boolean simplifications to arrive at the simplest expression for this truth table. Which technique would they prefer to use, and why?

Notes 72

One of the things you may want to have your students share in front of the class is their Karnaugh maps, and how they grouped common output states to arrive at Boolean expression terms. I have found that an overhead (acetate) or computer-projected image of a blank Karnaugh map on a whiteboard serves well to present Karnaugh maps on. This way, cell entries may be easily erased and re-drawn without having to re-draw the map (grid lines) itself.

Notes 73

One of the things you may want to have your students share in front of the class is their Karnaugh maps, and how they grouped common output states to arrive at Boolean expression terms. I have found that an overhead (acetate) or computer-projected image of a blank Karnaugh map on a whiteboard serves well to present Karnaugh maps on. This way, cell entries may be easily erased and re-drawn without having to re-draw the map (grid lines) itself.

This is one of those situations where an important group "wraps around" the edge of the Karnaugh map, and thus is likely to be overlooked by students.

Notes 74

One of the things you may want to have your students share in front of the class is their Karnaugh maps, and how they grouped common output states to arrive at Boolean expression terms. I have found that an overhead (acetate) or computer-projected image of a blank Karnaugh map on a whiteboard serves well to present Karnaugh maps on. This way, cell entries may be easily erased and re-drawn without having to re-draw the map (grid lines) itself.

This is one of those situations where an important group "wraps around" the edge of the Karnaugh map, and thus is likely to be overlooked by students.

Notes 75

Given the preponderance of 1's in this truth table, it is rational to try developing a POS expression rather than an SOP expression. However, your students may find that the elegance of Karnaugh mapping makes it easy enough to do it both ways! This is one question where you definitely want to have your students explain their methods of solution in front of the class, and you definitely want them to see how Karnaugh maps could be used both ways (SOP and POS).

I have found that an overhead (acetate) or computer-projected image of a blank Karnaugh map on a whiteboard serves well to present Karnaugh maps on. This way, cell entries may be easily erased and re-drawn without having to re-draw the map (grid lines) itself.

Notes 76

Just a preview of DeMorgan's Theorem here!

Notes 77

This question introduces DeMorgan's Theorem via a process of discovery. Students, seeing that these equivalent gates pairs have the same functionality, should be able to discern a general pattern (i.e. a rule) for breaking long bars in Boolean expressions.

Notes 78

There are many suitable references for students to be able to learn DeMorgan's Theorem from. Let them do the research on their own! Your task is to clarify any misunderstandings after they've done their jobs.

Notes 79

Have your students demonstrate exactly what they did (step by step) to simplify this expression, sharing their problem-solving strategies with the whole class.

Notes 80

Have your students demonstrate exactly what they did (step by step) to simplify this expression, sharing their problem-solving strategies with the whole class.

Notes 81

Have your students demonstrate exactly what they did (step by step) to simplify this expression, sharing their problem-solving strategies with the whole class.

Ask your students to determine what a non-variable solution means for a circuit such as this in a practical sense. What would they suspect if they tried to simplify a digital circuit and obtained this kind of result?

Notes 82

Have your students explain the entire process they used in simplifying the gate circuit: developing the Boolean expression, simplifying that expression using Boolean algebra techniques, and then developing a new gate circuit from the simplified Boolean expression. By having your students share their thought processes with the whole class, you will increase the level of learning on the parts of presenter and viewer alike. Students presenting their solutions will gain a better understanding of how it works because the act of presenting helps consolidate what they already know. Students viewing the presentation will get to see another person's technique (rather than just the instructor's), which will allow them to see examples of how to do these processes cast in slightly different terms.

Notes 83

Ask your students to explain what advantages there may be to using the simplified relay circuit rather than the original (more complex) relay circuit shown in the question. What significance does this lend to learning Boolean algebra?

This is what Boolean algebra is really for: reducing the complexity of logic circuits. It is far too easy for students to lose sight of this fact, learning all the abstract rules and laws of Boolean algebra. Remember, in teaching Boolean algebra, you are supposed to be preparing students to perform manipulations of *electronic circuits*, not just equations.

Notes 84

Ask your students to explain what advantages there may be to using the simplified gate circuit rather than the original (more complex) gate circuit shown in the question. What significance does this lend to learning Boolean algebra?

This is what Boolean algebra is really for: reducing the complexity of logic circuits. It is far too easy for students to lose sight of this fact, learning all the abstract rules and laws of Boolean algebra. Remember, in teaching Boolean algebra, you are supposed to be preparing students to perform manipulations of *electronic circuits*, not just equations.

Notes 85

An important aspect of long "bars" for students to recognize is that they function as *grouping symbols*. When applying DeMorgan's Theorem to breaking these bars, students often make the mistake of ignoring the grouping implicit in the original bars.

I highly recommend you take your class through the exercise suggested in the answer, for those who do not understand the nature of the mistake. Let students draw each expression's equivalent circuit on the board in front of the class so everyone can see, and then let them observe the dramatic change spoken of at the place where the mistake is made. If students understand what DeMorgan's Theorem means for an individual gate (Neg-AND to NOR, Neg-OR to NAND, etc.), the gate diagrams will clearly reveal to them that something has gone wrong at that step.

For comparison, perform the same step-by-step translation of the *proper* Boolean simplification into gate diagrams. The transitions between diagrams will make far more sense, and students should be able to get a "circuit's view" of why complementation bars function as grouping symbols.

Notes 86

The Boolean simplification for this particular problem is tricky. Remind students that complementation bars act as *grouping symbols*, and that parentheses should be used when in doubt to maintain grouping after "breaking bars" with DeMorgan's Theorem.

Ask your students to compare the "simplified" circuit with the original circuit. Are any advantages apparent to the version given in the answer? Certainly, the Boolean expression for that version of the circuit is simpler compared to that of the original circuit, but is the circuit itself significantly improved?

This question underscores an important lesson about Boolean algebra and logic simplification in general: just because a mathematical expression is simpler does not necessarily mean that the expression's physical realization will be any simpler than the original!

Notes 87

Not only is the method shown in the answer not the only valid solution, but it may even be the worst one! Your students should be able to research or invent alternative inverter connections, so after asking them to present their alternatives, ask the class as a whole to decide which solution is better. Ask them to consider electrical parameters, such as propagation delay time and fan-out.

Notes 88

Not only is the method shown in the answer not the only valid solution, but it may even be the worst one! Your students should be able to research or invent alternative inverter connections, so after asking them to present their alternatives, ask the class as a whole to decide which solution is better. Ask them to consider electrical parameters, such as propagation delay time and fan-out.

Notes 89

This question is a precursor to having students create combinational gate circuits using nothing but NAND or NOR gates.

Notes 90

Notes 91

Gate universality is not just an esoteric property of logic gates. There are (or at least were) entire logic systems made up of nothing but one of these gate types! I once worked with a fellow who maintained gas turbine control systems for crude oil pumping stations. He told me that he has seen one manufacturer's turbine control system where the discrete logic was nothing but NAND gates, and another manufacturer's system where the logic was nothing but NOR gates. Needless to say, it was a bit of a challenge for him to transition between the two manufacturers' systems, since it was natural for him to "get used to" one of the gate types after doing troubleshooting work on either type of system.

Notes 92

An interesting feature of this circuit is the final three NAND gates: two NAND gates feeding into a third NAND gate is equivalent to two AND gates feeding into an OR gate, thanks to DeMorgan's Theorem!

Notes 93

This question is a really good one to ask your students *how* they arrived at a solution. It is easy enough to simply look at the given answer and repeat it, but of course the intent of this question is to get students to think how they might design such a circuit completely on their own.

Notes 94

In my very first technical job, I worked as a CNC maintenance technician in a small machine shop, maintaining computer-controlled machine tools such as mills and lathes. A really neat project I got to work on at that job was the conversion of a 1970's era American-made machine tool to modern Japanese computer control. A lot of logic in that old machine tool was implemented using relays, and we replaced the cabinets full of relays with solid-state logic in the Japanese control computer. Actually, the solid state logic was a *programmable logic controller* or *PLC* function inside the Japanese control computer rather than discrete semiconductor logic gates. However, we very well could have replaced relays with hard-wired gates. The purpose of this question, if you haven't guessed by now, is to familiarize students with the concept of replacing electromechanical relays with semiconductor logic gates, especially identical logic gates such as NOR gates which are "universal."

Notes 95

Here students see that even though two circuits are functionally identical (at least according to their respective Boolean expressions), they may not behave quite the same under adverse conditions (i.e. faulted switches or wiring). This is a very important thing for them to see, because it underscores the practical need to look beyond the immediate design criteria (Boolean function) and consider other parameters (failure mode).

Notes 96

It should be noted that the input states in this circuit are defined by the voltage levels, not by the contact status. In other words, a closed contact equals a "low" (0) logic state.

Here are some suggested Boolean expressions for your students to build gate circuits from:

- Output = $AB + A$
- Output = $\overline{A}B + A$
- Output = $(A + B)A$
- Output = $(A + B)B$
- Output = $\overline{A} + B$
- Output = $A + \overline{B}$
- Output = $\overline{A}B$
- Output = $A\overline{B}$

Notes 97

It should be noted that the input states in this circuit are defined by the voltage levels, not by the contact status. In other words, a closed contact equals a "low" (0) logic state.

Suggested truth tables include the following (encoded as Boolean SOP statements):

- $ABC\bar{C} + ABC$
- $\bar{A}BC + \bar{A}BC$
- $\bar{A}BC + \bar{A}BC + \bar{A}\bar{B}\bar{C}$
- $\bar{A}\bar{B}\bar{C} + A\bar{B}\bar{C}$
- $ABC + \bar{A}\bar{B}\bar{C} + \bar{A}\bar{B}\bar{C}$
- $\bar{A}BC + \bar{A}\bar{B}C + \bar{A}\bar{B}\bar{C}$
- $ABC + \bar{A}BC + ABC$
- $\bar{A}BC + \bar{A}\bar{B}C + \bar{A}\bar{B}\bar{C}$
- $ABC + \bar{A}BC + \bar{A}\bar{B}C$

I strongly recommend having students build their logic circuits with CMOS chips rather than TTL, because of the less stringent power supply requirements of CMOS. I also recommend drawing a combinational circuit using four gates, because this is the common number of two-input gates found on 14-pin DIP logic chips.

Notes 98

Here, I let students choose appropriate values for R_{pullup} and R_{limit} , rather than specify them as given conditions.

Notes 99

The purpose of this assessment rubric is to act as a sort of "contract" between you (the instructor) and your student. This way, the expectations are all clearly known in advance, which goes a long way toward disarming problems later when it is time to grade.

Notes 100

This is a very useful way to think of the different logic gate types, as often you are faced with a choice of which gate type to use for a specific function in a digital circuit based on a requirement cast in these terms ("Any *blank* input guarantees a *blank* output").

For example, we might need a gate to perform a "disable" function for a digital signal:

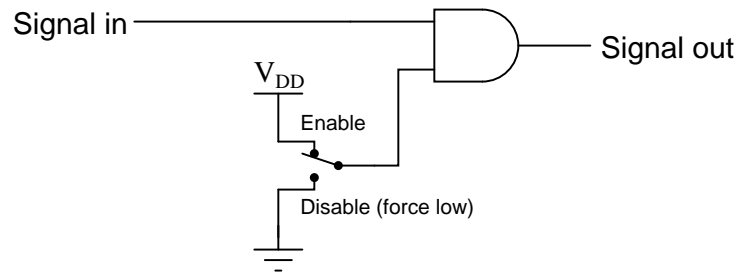

Considered in terms of what input state forces a low output, the choice to use an AND gate becomes obvious.

Notes 101

This is a very useful way to think of the different logic gate types, as it is often required to use a gate as a controlled buffer or controlled inverter.

Notes 102

The purpose of this question is to approach the domain of circuit troubleshooting from a perspective of knowing what the fault is, rather than only knowing what the symptoms are. Although this is not necessarily a realistic perspective, it helps students build the foundational knowledge necessary to diagnose a faulted circuit from empirical data. Questions such as this should be followed (eventually) by other questions asking students to identify likely faults based on measurements.

Notes 103

The purpose of this question is to approach the domain of circuit troubleshooting from a perspective of knowing what the fault is, rather than only knowing what the symptoms are. Although this is not necessarily a realistic perspective, it helps students build the foundational knowledge necessary to diagnose a faulted circuit from empirical data. Questions such as this should be followed (eventually) by other questions asking students to identify likely faults based on measurements.

Notes 104

The purpose of this question is to approach the domain of circuit troubleshooting from a perspective of knowing what the fault is, rather than only knowing what the symptoms are. Although this is not necessarily a realistic perspective, it helps students build the foundational knowledge necessary to diagnose a faulted circuit from empirical data. Questions such as this should be followed (eventually) by other questions asking students to identify likely faults based on measurements.

Notes 105

The purpose of this question is to approach the domain of circuit troubleshooting from a perspective of knowing what the fault is, rather than only knowing what the symptoms are. Although this is not necessarily a realistic perspective, it helps students build the foundational knowledge necessary to diagnose a faulted circuit from empirical data. Questions such as this should be followed (eventually) by other questions asking students to identify likely faults based on measurements.

Notes 106

The purpose of this question is to approach the domain of circuit troubleshooting from a perspective of knowing what the fault is, rather than only knowing what the symptoms are. Although this is not necessarily a realistic perspective, it helps students build the foundational knowledge necessary to diagnose a faulted circuit from empirical data. Questions such as this should be followed (eventually) by other questions asking students to identify likely faults based on measurements.

Notes 107

Discuss your students' answers to this question and their troubleshooting strategies. The latter part of the question, where students are asked to explain what they would do next, is the most important part!

Notes 108

This is a very practical question, as it requires students to carefully consider what a three-input AND gate *ought* to do under normal conditions, and how to set up a test that is indeed valid.

Notes 109

Be sure to leave plenty of classroom time for a discussion on troubleshooting this circuit. Electrical troubleshooting is a difficult-to-develop skill, and it takes lots of time for some people to acquire. Being one of the most valuable skills a technical person can possess, it is well worth the time invested!

The challenge question is very practical. Too many times I have seen students take meter measurements when their other senses provide enough data to render that step unnecessary. While there is nothing wrong with using your meter to confirm a suspicion, the best troubleshooters use all their senses (safely, of course) in the isolation of system faults.

Notes 110

Factoring really does seem to be a more difficult pattern-recognition skill to master than distribution, the latter being self-explanatory to many students. The purpose of this question is to get students to recognize and articulate the pattern-matching process involved with factoring. Once students have a working explanation of how to factor (especially if phrased in their own words), they will be better equipped to do so when needed.

Notes 111

This question stands as an example of how NAND gates may be used to construct different types of logic functions. In fact, with a sufficient quantity of NAND gates, *any* logic function may be built. This is why NAND gates are said to be "universal."

Notes 112

This question stands as an example of how NOR gates may be used to construct different types of logic functions. In fact, with a sufficient quantity of NOR gates, *any* logic function may be built. This is why NOR gates are said to be "universal."

Notes 113

This is a very practical application of DeMorgan's Theorem. Being able to use all NAND gates to implement an SOP function is a bonus over having to use separate AND and OR integrated circuit packages (one IC instead of two in this particular case).

Notes 114

This particular circuit is an example of how a combinational logic function may be implemented using nothing but NAND gates.

Notes 115

This particular circuit is an example of how a combinational logic function may be implemented using nothing but NAND gates.

Notes 116

This shows a very practical example of SOP and POS Boolean forms, and why simplification is necessary to reduce the number of required gates to a practical minimum.