

Series-parallel DC circuits

This worksheet and all related files are licensed under the Creative Commons Attribution License, version 1.0. To view a copy of this license, visit <http://creativecommons.org/licenses/by/1.0/>, or send a letter to Creative Commons, 559 Nathan Abbott Way, Stanford, California 94305, USA. The terms and conditions of this license allow for free copying, distribution, and/or modification of all licensed works by the general public.

Resources and methods for learning about these subjects (list a few here, in preparation for your research):

Question 1

Identify which of these components are connected directly in series with each other, and which are connected directly in parallel with each other:

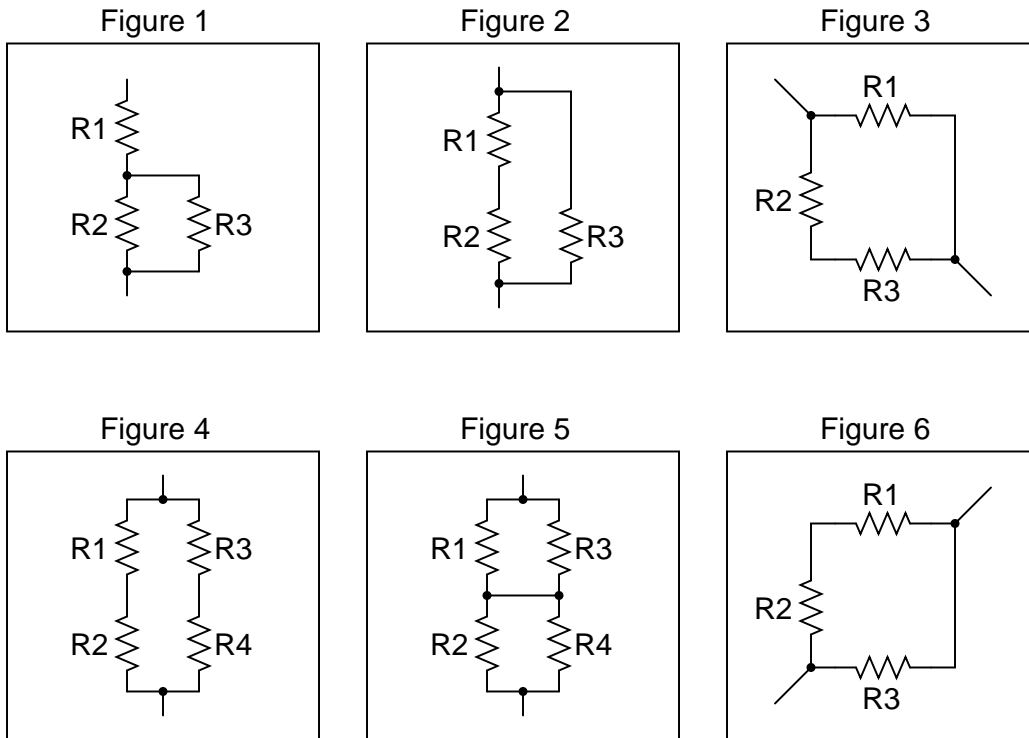

Assume that the open wire ends are connection points to a power source.

[file 01752](#)

Answer 1

Figure 1:

R2 in parallel with R3.

Figure 2:

R1 in series with R2.

Figure 3:

R2 in series with R3.

Figure 4:

R1 in series with R2; R3 in series with R4.

Figure 5:

R1 in parallel with R3; R2 in parallel with R4.

Figure 6:

R1 in series with R2.

Work with your students to clearly identify rules by which series and parallel connections may be identified. This is extremely important for students to grasp if they are to be successful analyzing series-parallel networks of any kind. The most common problems I encounter as an electronics instructor with reference to series-parallel are invariably related to students' lack of ability to consistently distinguish series sub-networks and parallel sub-networks in series-parallel combination circuits.

Question 2

Identify which of these components are connected directly in series with each other, and which are connected directly in parallel with each other:

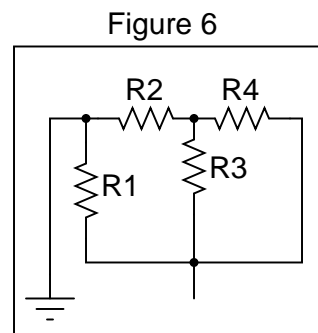
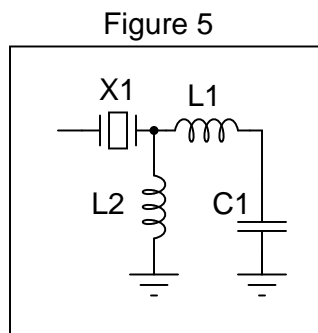
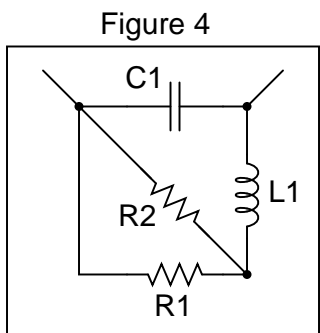
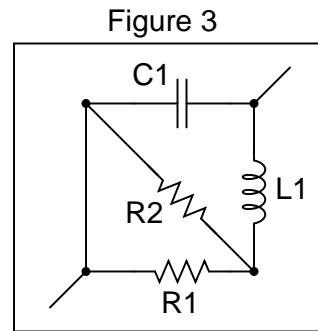
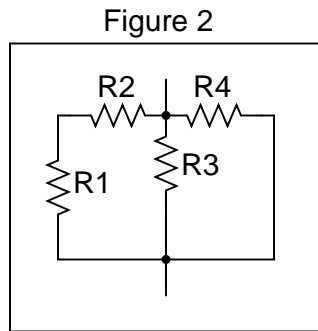
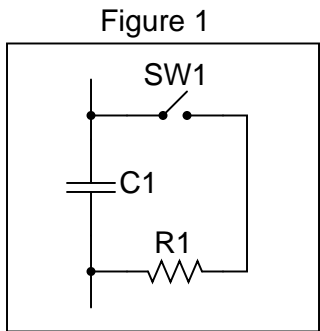

Assume that the open wire ends are connection points to a power source. In circuits where ground symbols appear, consider ground as the other side of the power source.

[file 01753](#)

Answer 2

Figure 1:

R1 in series with SW1.

Figure 2:

R1 in series with R2; R3 in parallel with R4.

Figure 3:

R1 parallel with R2.

Figure 4:

R1 parallel with R2.

Figure 5:

L1 in series with C1.

Figure 6:

R3 in parallel with R4.

Challenge question: if you compare figures 2 and 6, you see how merely changing the location(s) where the power supply connects to the network can alter the series/parallel relationships of the components. But, exactly what is it that is altered? If two components are in series with each other in one power source configuration, can that series relationship change by moving the power supply connection points? How about parallel connections? If two components are in parallel with each other, can that parallel relationship become altered merely by moving the points where the power source connects to the network? Explain.

Notes 2

Work with your students to clearly identify rules by which series and parallel connections may be identified. This is extremely important for students to grasp if they are to be successful analyzing series-parallel networks of any kind. The most common problems I encounter as an electronics instructor with reference to series-parallel are invariably related to students' lack of ability to consistently distinguish series sub-networks and parallel sub-networks in series-parallel combination circuits.

Question 3

Identify which of these components are connected directly in series with each other, and which are connected directly in parallel with each other:

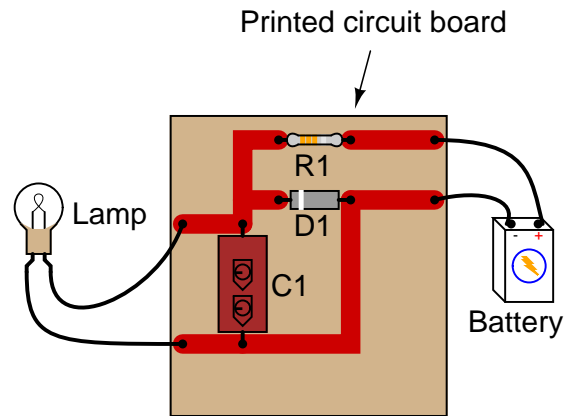

file 00031

Answer 3

Connected directly in series: *Battery and R1.*

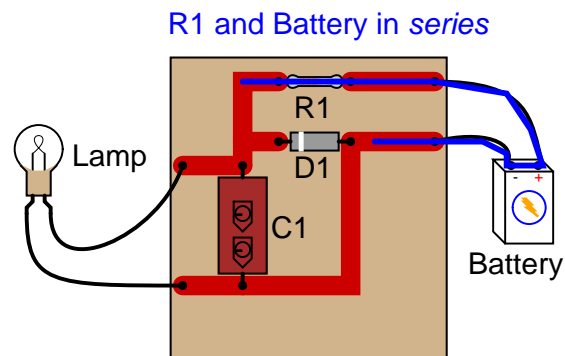

Connected directly in parallel: *Lamp, C1, and D1*

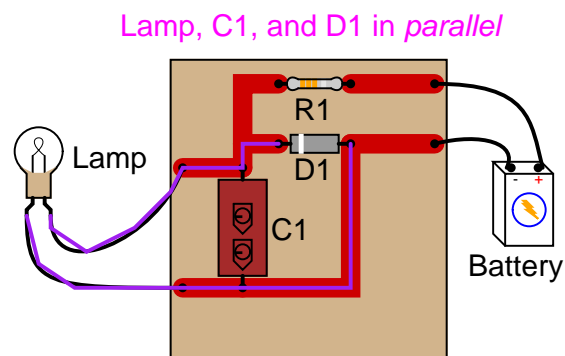

Students must have a firm understanding of what constitutes "series" versus "parallel" in real circuits. Here is a place where some students will feel uncomfortable because the textbook definitions they memorized are easier said than applied. It is imperative that students have a strong working knowledge of terms, and do not simply memorize definitions.

Question 4

Identify which of these components are connected directly in series with each other, and which are connected directly in parallel with each other:

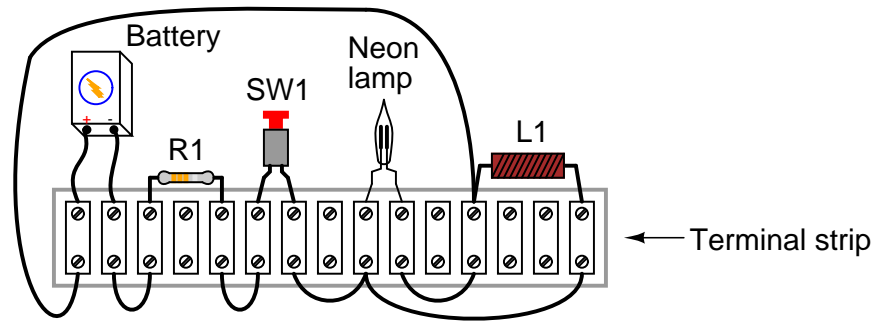

[file 00032](#)

Answer 4

Connected directly in series: *Battery, R1, and SW1*. Connected directly in parallel: *Neon lamp and L1*.

Notes 4

Students must have a firm understanding of what constitutes "series" versus "parallel" in real circuits. Here is a place where some students will feel uncomfortable because the textbook definitions they memorized are easier said than applied. It is imperative that students have a strong working knowledge of terms, and do not simply memorize definitions.

Question 5

In a series circuit, certain general rules may be stated with regard to quantities of voltage, current, resistance, and power. Express these rules, using your own words:

"In a series circuit, voltage . . ."

"In a series circuit, current . . ."

"In a series circuit, resistance . . ."

"In a series circuit, power . . ."

For each of these rules, explain *why* it is true.

file 00291

Answer 5

"In a series circuit, voltage *drops add to equal the total.*"

"In a series circuit, current *is equal through all components.*"

"In a series circuit, resistances *add to equal the total.*"

"In a series circuit, power *dissipations add to equal the total.*"

Notes 5

Rules of series and parallel circuits are very important for students to comprehend. However, a trend I have noticed in many students is the habit of memorizing rather than understanding these rules. Students will work hard to memorize the rules without really comprehending *why* the rules are true, and therefore often fail to recall or apply the rules properly.

An illustrative technique I have found very useful is to have students create their own example circuits in which to test these rules. Simple series and parallel circuits pose little challenge to construct, and therefore serve as excellent learning tools. What could be better, or more authoritative, than learning principles of circuits from real experiments? This is known as *primary research*, and it constitutes the foundation of scientific inquiry. The greatest problem you will have as an instructor is encouraging your students to take the initiative to build these demonstration circuits on their own, because they are so used to having teachers simply *tell* them how things work. This is a shame, and it reflects poorly on the state of modern education.

Question 6

In a parallel circuit, certain general rules may be stated with regard to quantities of voltage, current, resistance, and power. Express these rules, using your own words:

"In a parallel circuit, voltage . . ."

"In a parallel circuit, current . . ."

"In a parallel circuit, resistance . . ."

"In a parallel circuit, power . . ."

For each of these rules, explain *why* it is true.

file 00292

Answer 6

"In a parallel circuit, voltage *is equal across all components.*"

"In a parallel circuit, currents *add to equal the total.*"

"In a parallel circuit, resistances *diminish to equal the total.*"

"In a parallel circuit, power *dissipations add to equal the total.*"

Notes 6

Rules of series and parallel circuits are very important for students to comprehend. However, a trend I have noticed in many students is the habit of memorizing rather than understanding these rules. Students will work hard to memorize the rules without really comprehending *why* the rules are true, and therefore often fail to recall or apply the rules properly.

An illustrative technique I have found very useful is to have students create their own example circuits in which to test these rules. Simple series and parallel circuits pose little challenge to construct, and therefore serve as excellent learning tools. What could be better, or more authoritative, than learning principles of circuits from real experiments? This is known as *primary research*, and it constitutes the foundation of scientific inquiry. The greatest problem you will have as an instructor is encouraging your students to take the initiative to build these demonstration circuits on their own, because they are so used to having teachers simply *tell* them how things work. This is a shame, and it reflects poorly on the state of modern education.

Question 7

Rank these three light bulb assemblies according to their *total* electrical resistance (in order of least to greatest), assuming that each of the bulbs is the same type and rating:

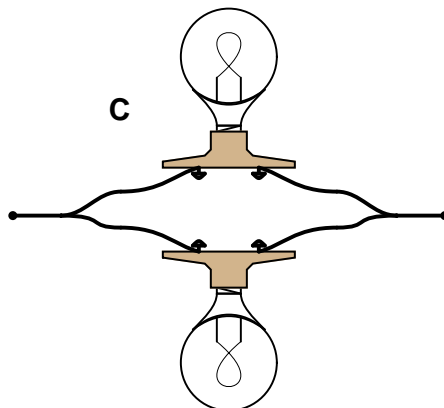
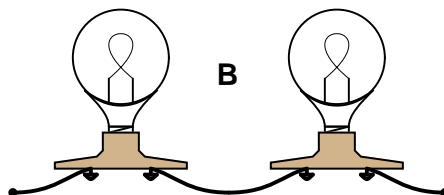
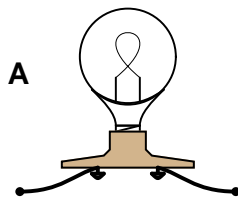

Explain how you determined the relative resistances of these light bulb networks.
[file 00030](#)

Answer 7

- C (least total resistance)
- A
- B (greatest total resistance)

Notes 7

I prefer to enter discussion on series and parallel circuits prior to introducing Ohm's Law. Conceptual analysis tends to be more difficult than numerical analysis in electric circuits, but is a skill worthwhile to build, especially for the sake of effective troubleshooting.

It is effective *after* conceptual (qualitative) analysis, though, to go through a numerical (quantitative) analysis of a circuit like this to prove that the concepts are correct, if the students are advanced enough at this point to do series-parallel resistance calculations.

Question 8

Which components are guaranteed to share the exact same *voltage* by virtue of their connections with each other? Which components are guaranteed to share the exact same *current* by virtue of their connections with each other?

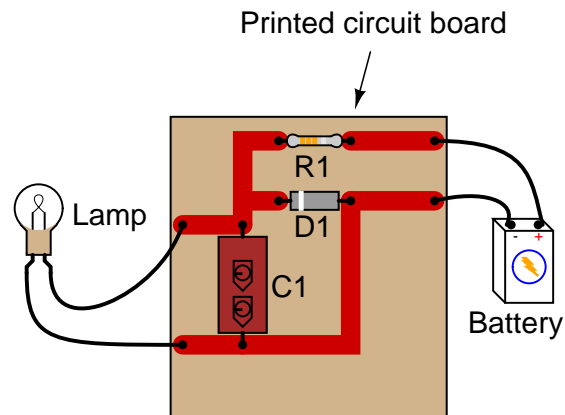

[file 00033](#)

Answer 8

The lamp, C1, and D1 are all guaranteed to share the exact same voltage. The battery and R1 are both guaranteed to share the exact same current.

Notes 8

Here, the important relations between voltage, current, and component connection patterns are explored. This serves to further define, in practical ways, what the terms "series" and "parallel" really mean.

Question 9

Which components in this partial automobile schematic diagram are guaranteed to share the exact same *voltage* by virtue of their connections with each other? Which components are guaranteed to share the exact same *current* by virtue of their connections with each other?

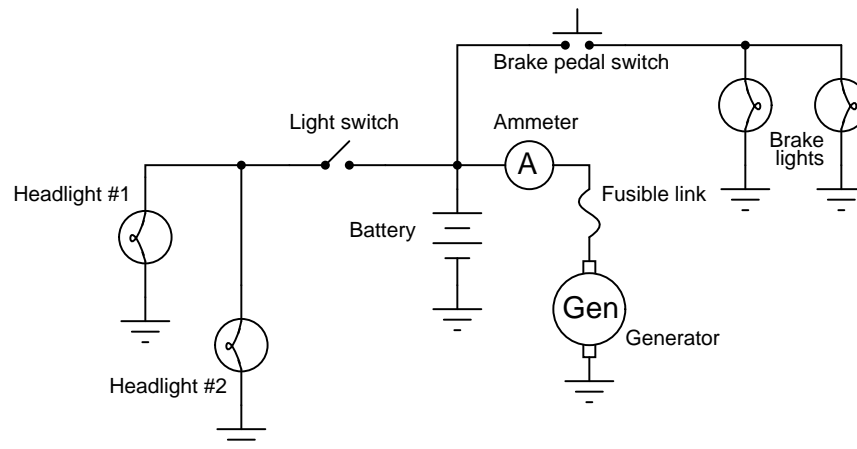

file 00034

Answer 9

The two headlights are guaranteed to share the same voltage. So are the two brake lights. However, the voltage across the brake lights may not be the same as the voltage across the headlights at any given time!

So long as the fusible link is not "blown," the generator and battery will share approximately the same voltage.

The ammeter, fusible link, and generator are all guaranteed to share the same current.

Notes 9

Here, the important relations between voltage, current, and component connection patterns are explored. This serves to further define, in practical ways, what the terms "series" and "parallel" really mean.

This question also affords the opportunity of discussing what a "fusible link" is, and how it compares to fuses and circuit breakers as an overcurrent protection device.

Question 10

Examine these two variable-resistance (*rheostat*) networks, each one with a large-range potentiometer and a small-range potentiometer:

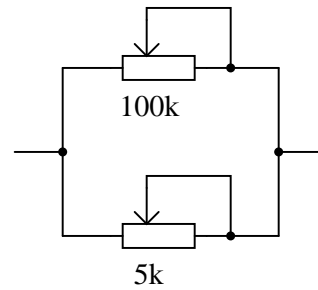
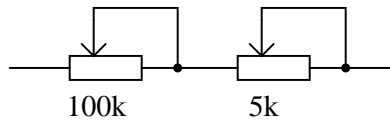

For each network, determine which pot is the *coarse* adjustment and which pot is the *fine* adjustment for total resistance.

[file 03454](#)

Answer 10

Series network

100k = Coarse adjustment ; 5k = Fine adjustment

Parallel network

5k = Coarse adjustment ; 100k = Fine adjustment

Notes 10

The purpose of this question is for students to identify the dominant resistance values in series versus parallel circuits. Remind your students if necessary that $R_{total} > R_n$ for series and $R_{total} < R_n$ for parallel (where R_n represents any particular resistor in the network).

Question 11

Draw a schematic diagram of this "breadboarded" circuit:

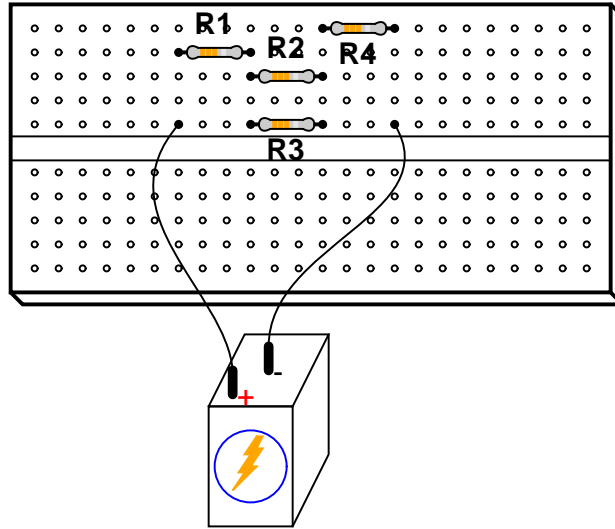

[file 01760](#)

Answer 11

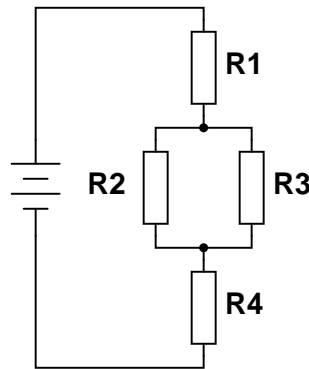

Notes 11

If your students are not yet aware of how solderless breadboard holes are connected together, this is a good time to introduce them!

Question 12

From observation of this circuit (with components attached to a "terminal strip"), draw an appropriate schematic diagram:

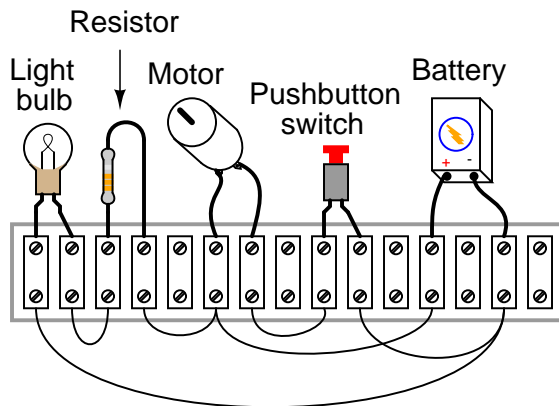

[file 00115](#)

Answer 12

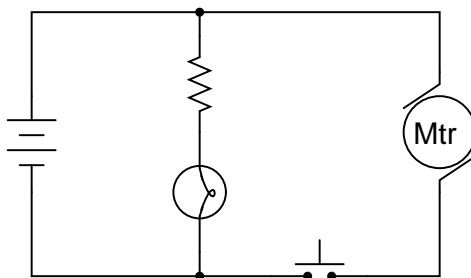

Notes 12

This type of question is one that lends itself well to students drawing their answers on the board in front of class. The skill of transferring a real circuit into a cleanly-drawn schematic is one that some students struggle mightily with, but it is important. Those students will want to know what technique(s) may be used to make the transfer. Students who are more spatially adept will probably have a couple of different ways to approach a problem such as this. Allow them to explain to the rest of the class their technique(s) for tracing the real circuit's wiring into a schematic diagram.

Giving students the opportunity to teach their peers is a powerful instructional method, and should be encouraged at all times!

Question 13

In this series-parallel circuit, resistors R1 and R2 are in series with each other, but resistor R3 is neither in series nor in parallel with either R1 or R2:

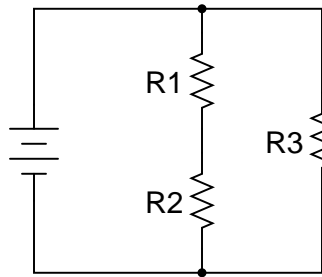

Normally, the first step in mathematically analyzing a circuit such as this is to determine the total circuit resistance. In other words, we need to calculate how much resistance the voltage source "sees" in the network formed by R1, R2, and R3. If the circuit were a simple series configuration, our task would be easy:

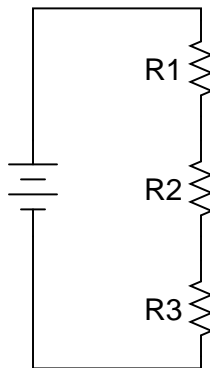

Likewise, if the circuit were a simple parallel configuration, we would have no difficulty at all calculating total resistance:

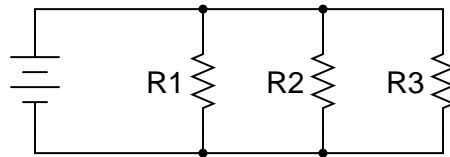

Due to the fact that our given circuit is neither purely series nor purely parallel, though, calculation of total resistance is not a simple one-step operation. However, there is a way we could simplify the circuit to something that *is* either simple series or simple parallel. Describe how that might be done, and demonstrate using numerical values for resistors R1, R2, and R3.

[file 01755](#)

Answer 13

Suppose we had these resistor values:

- $R1 = 3000 \Omega$
- $R2 = 2000 \Omega$
- $R3 = 5000 \Omega$

The total resistance in this case would be 2500Ω . I'll let you figure out how to do this!

Hint: $2.5k$ is exactly one-half of $5k$

Notes 13

Figuring out how to calculate total resistance in a series-parallel network is an exercise in problem-solving. Students must determine how to convert a complex problem into multiple, simpler problems which they can then solve with the tools they have.

This sort of exercise is also helpful in getting students to think in terms of *incremental* problem-solving. Being able to take sections of a circuit and reduce them to equivalent component values so that the circuit becomes simpler and simpler to analyze is a very important skill in electronics.

Question 14

Rank these five light bulb assemblies according to their *total* electrical resistance (in order of least to greatest), assuming that each of the bulbs is the same type and rating:

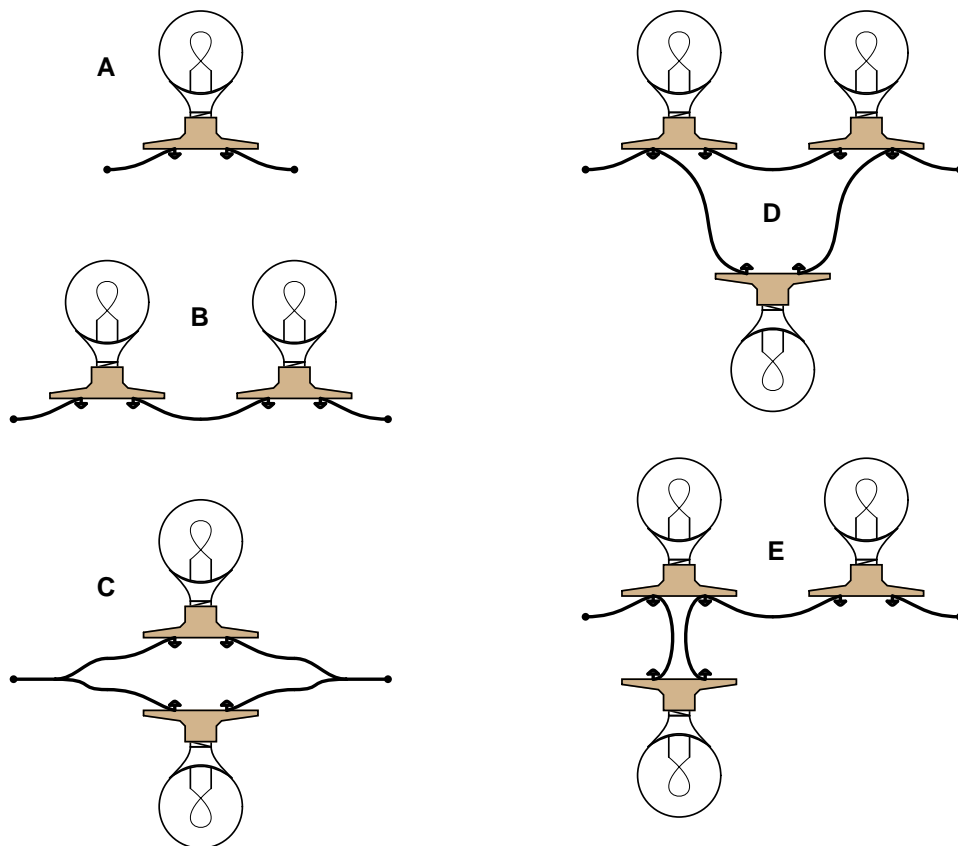

Explain how you determined the relative resistances of these light bulb networks.
[file 00039](#)

Answer 14

- C (least total resistance)
- D
- A
- E
- B (greatest total resistance)

Notes 14

I prefer to enter discussion on series and parallel circuits prior to introducing Ohm's Law. Conceptual analysis tends to be more difficult than numerical analysis in electric circuits, but is a skill worthwhile to build, especially for the sake of effective troubleshooting.

It is effective *after* conceptual (qualitative) analysis, though, to go through a numerical (quantitative) analysis of a circuit like this to prove that the concepts are correct, if the students are advanced enough at this point to do series-parallel resistance calculations.

Question 15

Determine the amount of electrical resistance indicated by an ohmmeter connected between the following points in this circuit:

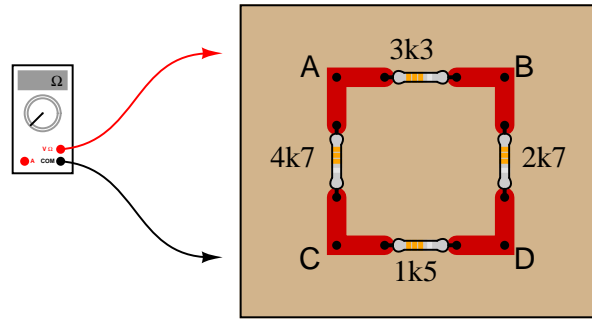

- Between points A and B =
- Between points A and C =
- Between points C and D =
- Between points D and B =
- Between points B and C =

Explain whether or not it makes any sense to speak of a "total" resistance for this network.
[file 01601](#)

Answer 15

- Between points A and B = $2.41\text{ k}\Omega$
- Between points A and C = $2.89\text{ k}\Omega$
- Between points C and D = $1.32\text{ k}\Omega$
- Between points D and B = $2.10\text{ k}\Omega$
- Between points B and C = $2.75\text{ k}\Omega$

Notes 15

The purpose of this question is to get students to realize that the resistance "looking into" different areas of a resistive network depends on what those areas are.

Question 16

Calculate the resistance between points **A** and **B** (R_{AB}) for the following resistor networks:

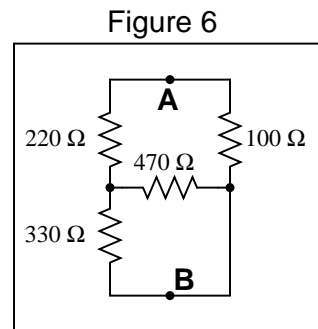
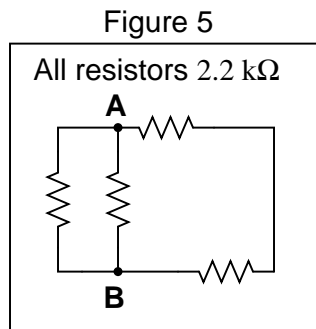
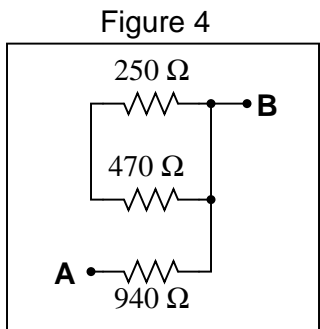
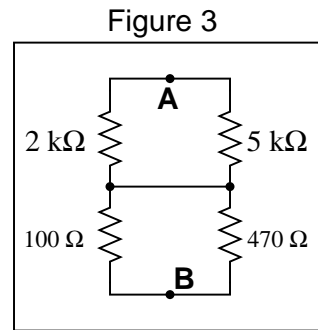
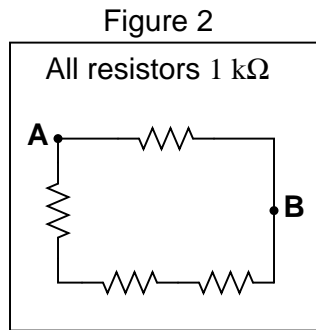
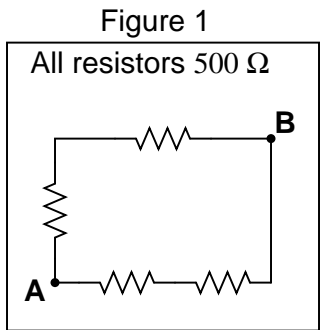

file 01757

Answer 16

Figure 1:

$$R_{AB} = 500\ \Omega$$

Figure 2:

$$R_{AB} = 750\ \Omega$$

Figure 3:

$$R_{AB} = 1.511\ \text{k}\Omega$$

Figure 4:

$$R_{AB} = 940\ \Omega$$

Figure 5:

$$R_{AB} = 880\ \Omega$$

Figure 6:

$$R_{AB} = 80.54\ \Omega$$

Note that the circuit in figure 4 is a "trick:" two of the resistors contribute absolutely nothing to R_{AB} ! Be sure to discuss why this is with your students.

Discuss with your students how they approached each of these problems, and let the entire class participate in the reasoning process. The point of this question, like most of the questions in the Socratic Electronics project, is not merely to obtain the correct answers, but to stimulate understanding of *how* to solve problems such as these.

Question 17

Calculate the amount of voltage dropped across resistor R_2 :

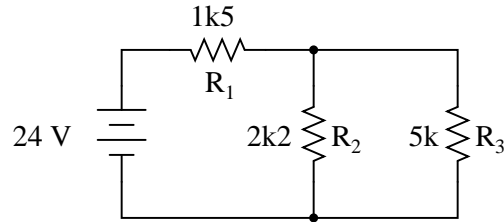

Also, note the direction of current through it and the polarity of the voltage drop across it.
[file 01759](#)

Answer 17

$V_{R_2} = 12.11$ volts, positive on top and negative on bottom. If you follow conventional flow notation, this means current goes down through resistor R_2 . The actual flow of electrons through R_2 , however, is up.

Notes 17

Discuss with your students how they obtained their answers for this question. The reasoning and procedures are far more important than the actual answer itself.

Students often have difficulty formulating a method of solution: determining what steps to take to get from the given conditions to a final answer. While it is helpful at first for you (the instructor) to show them, it is bad for you to show them too often, lest they stop thinking for themselves and merely follow your lead. A teaching technique I have found very helpful is to have students come up to the board (alone or in teams) in front of class to write their problem-solving strategies for all the others to see. They don't have to actually do the math, but rather outline the steps they would take, in the order they would take them.

By having students outline their problem-solving strategies, everyone gets an opportunity to see multiple methods of solution, and you (the instructor) get to see how (and if!) your students are thinking. An especially good point to emphasize in these "open thinking" activities is how to check your work to see if any mistakes were made.

Question 18

Complete the table of values for this circuit:

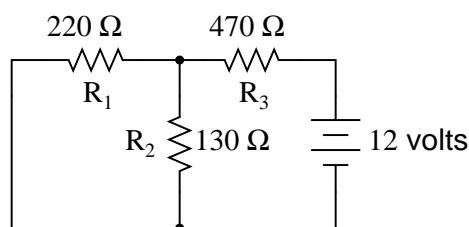

	R ₁	R ₂	R ₃	Total
V				
I				
R	220 Ω	130 Ω	470 Ω	
P				

[file 01758](#)

Answer 18

	R ₁	R ₂	R ₃	Total
V	1.778 V	1.778 V	10.22 V	12 V
I	8.079 mA	13.67 mA	21.75 mA	21.75 mA
R	220 Ω	130 Ω	470 Ω	551.7 Ω
P	14.36 mW	24.30 mW	222.3 mW	261.0 mW

Notes 18

Discuss with your students what a good procedure might be for calculating the unknown values in this problem, and also how they might check their work.

Students often have difficulty formulating a method of solution: determining what steps to take to get from the given conditions to a final answer. While it is helpful at first for you (the instructor) to show them, it is bad for you to show them too often, lest they stop thinking for themselves and merely follow your lead. A teaching technique I have found very helpful is to have students come up to the board (alone or in teams) in front of class to write their problem-solving strategies for all the others to see. They don't have to actually do the math, but rather outline the steps they would take, in the order they would take them.

By having students outline their problem-solving strategies, everyone gets an opportunity to see multiple methods of solution, and you (the instructor) get to see how (and if!) your students are thinking. An especially good point to emphasize in these "open thinking" activities is how to check your work to see if any mistakes were made.

Question 19

Complete the table of values for this circuit:

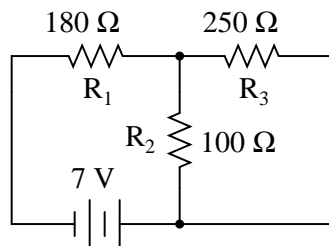

	R ₁	R ₂	R ₃	Total
V				
I				
R	180 Ω	100 Ω	250 Ω	
P				

[file 03259](#)

Answer 19

	R ₁	R ₂	R ₃	Total
V	5.01 V	1.99 V	1.99 V	7 V
I	27.84 mA	19.89 mA	7.95 mA	27.84 mA
R	180 Ω	100 Ω	250 Ω	251.4 Ω
P	139.5 mW	39.55 mW	15.82 mW	194.9 mW

Notes 19

Discuss with your students what a good procedure might be for calculating the unknown values in this problem, and also how they might check their work.

Students often have difficulty formulating a method of solution: determining what steps to take to get from the given conditions to a final answer. While it is helpful at first for you (the instructor) to show them, it is bad for you to show them too often, lest they stop thinking for themselves and merely follow your lead. A teaching technique I have found very helpful is to have students come up to the board (alone or in teams) in front of class to write their problem-solving strategies for all the others to see. They don't have to actually do the math, but rather outline the steps they would take, in the order they would take them.

By having students outline their problem-solving strategies, everyone gets an opportunity to see multiple methods of solution, and you (the instructor) get to see how (and if!) your students are thinking. An especially good point to emphasize in these "open thinking" activities is how to check your work to see if any mistakes were made.

Question 20

Complete the table of values for this circuit:

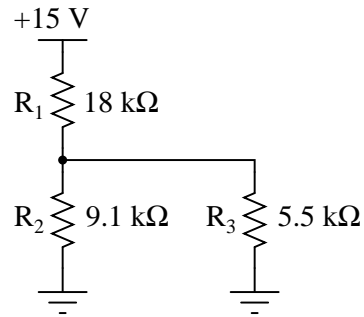

	R_1	R_2	R_3	Total
V				
I				
R	18 k Ω	9.1 k Ω	5.5 k Ω	
P				

[file 03268](#)

Answer 20

	R_1	R_2	R_3	Total
V	12.6 V	2.4 V	2.4 V	15 V
I	700 μ A	263.7 μ A	436.3 μ A	700 μ A
R	18 k Ω	9.1 k Ω	5.5 k Ω	21.43 k Ω
P	8.82 mW	632.8 μ W	1.05 mW	10.5 mW

Follow-up question: how much voltage is present at the node (junction point) where R_1 , R_2 , and R_3 all connect together, measured with reference to ground?

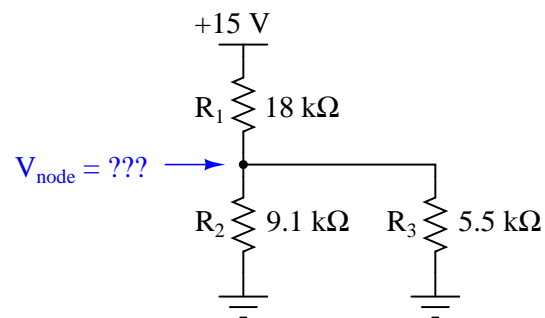

A noteworthy feature of this circuit's schematic is how the power supply connections are shown. Unlike many of my schematic diagrams, I do not show a "battery" symbol here for a voltage source. Instead, I show power supply "rail" symbols (flat line and a ground symbol). Let your students know that this is very common symbolism in modern schematics, and that it merely saves having to draw lines to a voltage source symbol (as well as the source symbol itself).

Discuss with your students what a good procedure might be for calculating the unknown values in this problem, and also how they might check their work.

Students often have difficulty formulating a method of solution: determining what steps to take to get from the given conditions to a final answer. While it is helpful at first for you (the instructor) to show them, it is bad for you to show them too often, lest they stop thinking for themselves and merely follow your lead. A teaching technique I have found very helpful is to have students come up to the board (alone or in teams) in front of class to write their problem-solving strategies for all the others to see. They don't have to actually do the math, but rather outline the steps they would take, in the order they would take them.

By having students outline their problem-solving strategies, everyone gets an opportunity to see multiple methods of solution, and you (the instructor) get to see how (and if!) your students are thinking. An especially good point to emphasize in these "open thinking" activities is how to check your work to see if any mistakes were made.

Question 21

Complete the table of values for this circuit:

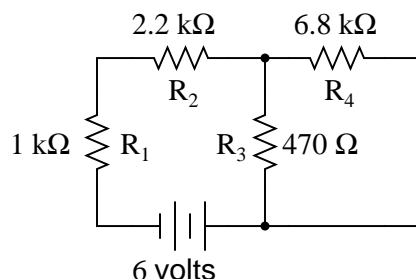

	R ₁	R ₂	R ₃	R ₄	Total
V					
I					
R	1 kΩ	2.2 kΩ	470 Ω	6.8 kΩ	
P					

[file 01756](#)

Answer 21

	R ₁	R ₂	R ₃	R ₄	Total
V	1.649 V	3.627 V	725 mV	725 mV	6 V
I	1.649 mA	1.649 mA	1.542 mA	107 μA	1.649 mA
R	1 kΩ	2.2 kΩ	470 Ω	6.8 kΩ	3.64 kΩ
P	2.718 mW	5.979 mW	1.117 mW	77.24 μW	9.891 mW

Notes 21

Discuss with your students what a good procedure might be for calculating the unknown values in this problem, and also how they might check their work.

Students often have difficulty formulating a method of solution: determining what steps to take to get from the given conditions to a final answer. While it is helpful at first for you (the instructor) to show them, it is bad for you to show them too often, lest they stop thinking for themselves and merely follow your lead. A teaching technique I have found very helpful is to have students come up to the board (alone or in teams) in front of class to write their problem-solving strategies for all the others to see. They don't have to actually do the math, but rather outline the steps they would take, in the order they would take them.

By having students outline their problem-solving strategies, everyone gets an opportunity to see multiple methods of solution, and you (the instructor) get to see how (and if!) your students are thinking. An especially good point to emphasize in these "open thinking" activities is how to check your work to see if any mistakes were made.

Question 22

Complete the table of values for this circuit:

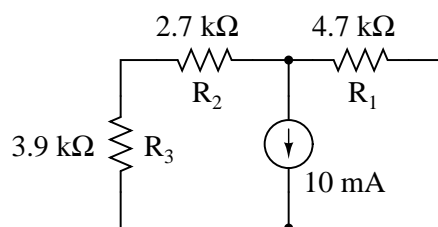

	R ₁	R ₂	R ₃	Total
V				
I				10 mA
R	4.7 kΩ	2.7 kΩ	3.9 kΩ	
P				

file 03256

Answer 22

	R ₁	R ₂	R ₃	Total
V	27.45 V	11.23 V	16.22 V	27.45 V
I	5.841 mA	4.159 mA	4.159 mA	10 mA
R	4.7 kΩ	2.7 kΩ	3.9 kΩ	2.745 kΩ
P	160.3 mW	46.71 mW	67.47 mW	274.5 mW

Notes 22

Discuss with your students what a good procedure might be for calculating the unknown values in this problem, and also how they might check their work.

Students often have difficulty formulating a method of solution: determining what steps to take to get from the given conditions to a final answer. While it is helpful at first for you (the instructor) to show them, it is bad for you to show them too often, lest they stop thinking for themselves and merely follow your lead. A teaching technique I have found very helpful is to have students come up to the board (alone or in teams) in front of class to write their problem-solving strategies for all the others to see. They don't have to actually do the math, but rather outline the steps they would take, in the order they would take them.

By having students outline their problem-solving strategies, everyone gets an opportunity to see multiple methods of solution, and you (the instructor) get to see how (and if!) your students are thinking. An especially good point to emphasize in these "open thinking" activities is how to check your work to see if any mistakes were made.

Question 23

Determine which light bulb(s) will glow brightly, and which light bulb(s) will glow dimly (assuming all light bulbs are identical).

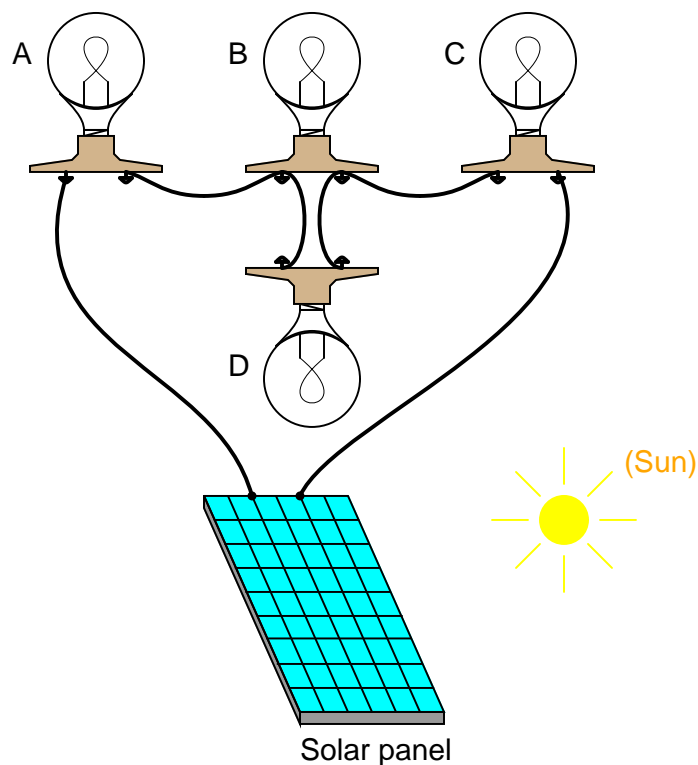

file 00040

Answer 23

Bulbs "A" and "C" will glow brightly, while bulbs "B" and "D" will glow dimly.

Follow-up question: explain why bulbs "A" and "C" will become dimmer (less bright) if the filament in bulb "D" fails open.

Notes 23

This question provides an opportunity to discuss current in series- versus parallel-connected components. The follow-up question challenges students to qualitatively analyze the circuit.

Question 24

Antique American automobiles often used 6 volt electrical systems instead of the 12 volt components found in more modern cars and trucks. People who restore these old vehicles may have difficulty finding old 6-volt generators and batteries to replace the defective, original units. An easy solution is to update the vehicle's generator and battery with modern (12 volt) components, but then another problem arises.

A 12 volt generator and 12 volt battery will overpower the old 6 volt headlights, brake lights, and other electrical "loads" in the vehicle. A solution used by antique automobile restorers is to connect resistors between the 12-volt generator system and the 6-volt loads, like this:

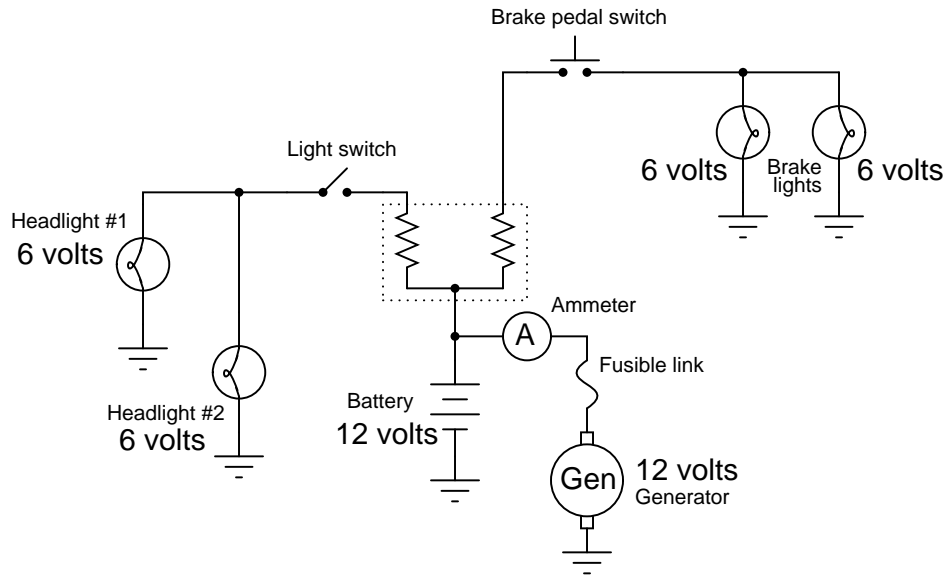

Explain why this solution works, and also discuss some of the disadvantages of using resistors to adapt the new (12 volt) to the old (6 volt) components.

[file 00062](#)

Answer 24

The purpose of the resistors is to "drop" half the voltage supplied by the generator and battery, so that the loads (light bulbs, in this case) receive only 6 volts instead of 12 volts. A disadvantage of using resistors to do this is that the resistors waste a lot of electrical power in the form of heat.

Notes 24

Make sure your students understand the concept of a "load:" any electrical or electronic component that uses power from an electrical source. Usually, "loads" are the end-use components of a circuit: light bulbs, motors, solenoids, speakers, etc. In this case, the resistors could be considered loads as well as the light bulbs, but since the light bulbs are the only components performing useful work from the power source, it is customary to think of them when the word "load" is used, rather than the resistors.

Question 25

Think of a way to re-wire the electrical system of this old automobile (with 6-volt light bulbs) so as to not require resistors between the loads and the generator/battery portion of the circuit (operating at 12 volts each).

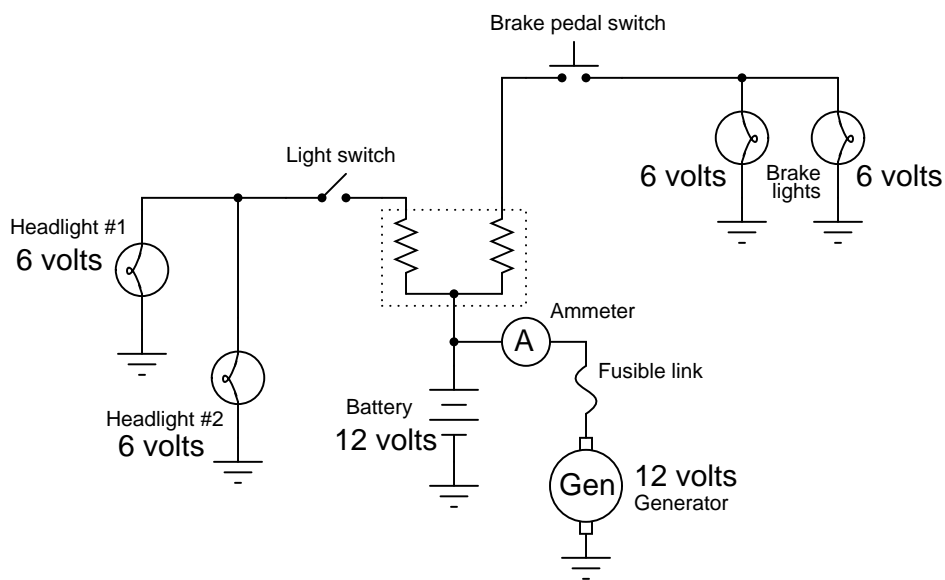

[file 00063](#)

Answer 25

Connect the light bulb pairs in series instead of parallel. This way, each light bulb will receive 6 volts, with a total system voltage of 12 volts.

Follow-up question: there is a disadvantage of this strategy, though, and it concerns the safety of operating the automobile. Explain what this disadvantage is.

Notes 25

This solution works only because the load sets are in pairs, and because $6 + 6 = 12$. One benefit of this solution is greater efficiency, as there are no resistors in the circuit to "waste" power by dissipating it in the form of heat. However, there is a disadvantage to doing things this way, as indicated by the follow-up question. Discuss this disadvantage with your students, reinforcing the idea that the most efficient engineering solutions may not be the best when assessed from other perspectives, such as safety!

Question 26

Calculate the voltage drops V_{AB} , V_{BC} , and V_{CD} in the following circuit:

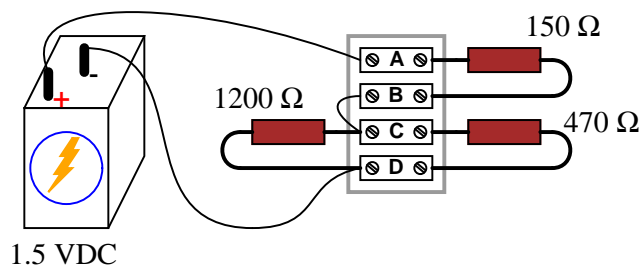

file 01764

Answer 26

$$V_{AB} = 461 \text{ mV}$$

$$V_{BC} = 0 \text{ V}$$

$$V_{CD} = 1.039 \text{ V}$$

Follow-up question: explain why the voltage between points A and B (V_{AB}) would *increase* if the 1200 Ω resistor were to fail shorted. Hint: imagine a "jumper" wire connected across that resistor to simulate a shorted failure.

Challenge question: explain how you can calculate these same answers without ever having to calculate total circuit current.

Notes 26

Ask your students how they could tell V_{BC} must be zero, just by examining the circuit (without doing any math). If some students experience difficulty answering this question on their own, have them translate the drawing into a proper schematic diagram.

Students often have difficulty formulating a method of solution: determining what steps to take to get from the given conditions to a final answer. While it is helpful at first for you (the instructor) to show them, it is bad for you to show them too often, lest they stop thinking for themselves and merely follow your lead. A teaching technique I have found very helpful is to have students come up to the board (alone or in teams) in front of class to write their problem-solving strategies for all the others to see. They don't have to actually do the math, but rather outline the steps they would take, in the order they would take them.

By having students outline their problem-solving strategies, everyone gets an opportunity to see multiple methods of solution, and you (the instructor) get to see how (and if!) your students are thinking. An especially good point to emphasize in these "open thinking" activities is how to check your work to see if any mistakes were made.

Question 27

Calculate the voltage magnitude and polarity between points **A** and **D** in this circuit, assuming a power supply output voltage of 10.5 volts:

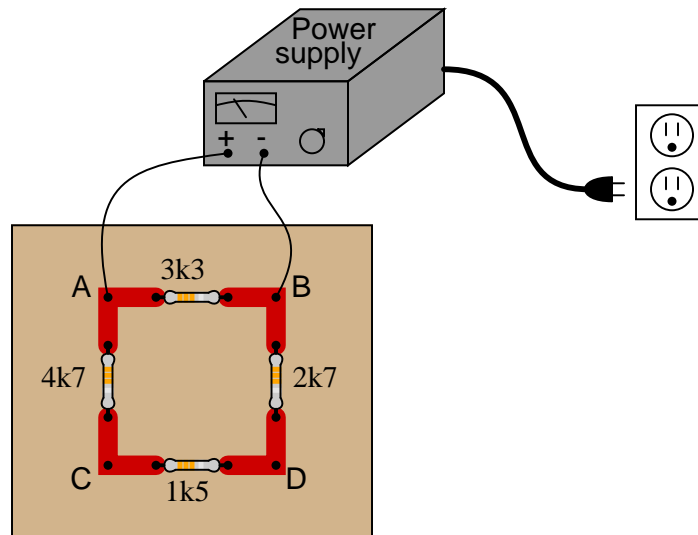

Also, calculate the total current output by the power supply as it energizes this resistor network.
[file 01765](#)

Answer 27

$V_{AD} = 7.31$ volts, **A** positive and **D** negative. The total power supply current is 4.36 mA.

Follow-up question: explain why the voltage across the 4.7 k Ω resistor would go to zero if the 1.5 k Ω resistor were to fail open.

Notes 27

Though some students might not realize it at first, there is no series-parallel analysis necessary to obtain the voltage drop V_{AD} .

Students often have difficulty formulating a method of solution: determining what steps to take to get from the given conditions to a final answer. While it is helpful at first for you (the instructor) to show them, it is bad for you to show them too often, lest they stop thinking for themselves and merely follow your lead. A teaching technique I have found very helpful is to have students come up to the board (alone or in teams) in front of class to write their problem-solving strategies for all the others to see. They don't have to actually do the math, but rather outline the steps they would take, in the order they would take them.

By having students outline their problem-solving strategies, everyone gets an opportunity to see multiple methods of solution, and you (the instructor) get to see how (and if!) your students are thinking. An especially good point to emphasize in these "open thinking" activities is how to check your work to see if any mistakes were made.

As a follow-up to the follow-up question, ask your students what *other* resistor in this circuit would completely lose voltage given an open failure of the 1.5 k Ω resistor.

Question 28

Calculate the power supply's output (total) current:

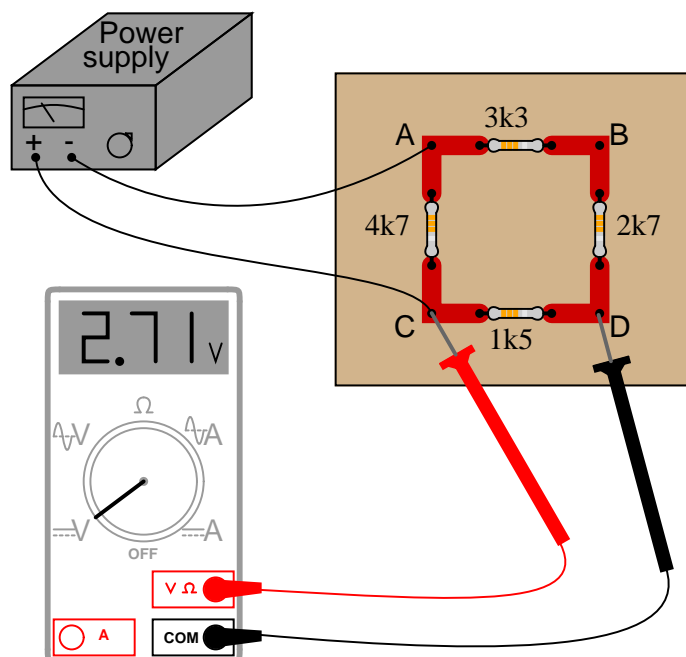

[file 01766](#)

Answer 28

$$I_{total} = 4.69 \text{ mA}$$

Follow-up question: explain why the voltage across the 1500 Ω resistor would remain unchanged if the 4700 Ω resistor were to fail open.

Challenge question: what crucial assumptions underlie the calculated figure for current shown here? In other words, what unknown quantities can affect the accuracy of our predicted current value?

Notes 28

This is an interesting series-parallel circuit problem to solve, and it shows once again how a good understanding of circuit theory enables unmeasured variables to be inferred.

Students often have difficulty formulating a method of solution: determining what steps to take to get from the given conditions to a final answer. While it is helpful at first for you (the instructor) to show them, it is bad for you to show them too often, lest they stop thinking for themselves and merely follow your lead. A teaching technique I have found very helpful is to have students come up to the board (alone or in teams) in front of class to write their problem-solving strategies for all the others to see. They don't have to actually do the math, but rather outline the steps they would take, in the order they would take them.

By having students outline their problem-solving strategies, everyone gets an opportunity to see multiple methods of solution, and you (the instructor) get to see how (and if!) your students are thinking. An especially good point to emphasize in these "open thinking" activities is how to check your work to see if any mistakes were made.

Question 29

Suppose you were designing a circuit that required two LEDs for "power on" indication. The power supply voltage is 15 volts, and each LED is rated at 1.6 volts and 20 mA. Calculate the dropping resistor sizes and power ratings:

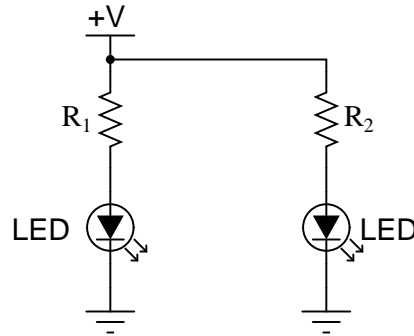

After doing this, a co-worker looks at your circuit and suggests a modification. Why not use a single dropping resistor for both LEDs, economizing the number of components necessary?

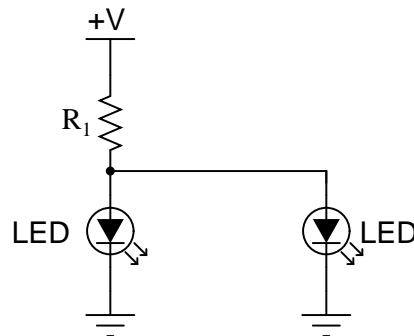

Re-calculate the dropping resistor ratings (resistance *and* power) for the new design.
[file 01777](#)

Answer 29

With two resistors: $R_1 = R_2 = 670 \Omega$, rated for at least 0.268 watts (1/2 watt would be a practical rating).

With one resistor: $R_1 = 335 \Omega$, rated for at least 0.536 watts (1 watt would be a practical rating).

Follow-up question: if there were no perfectly sized resistors sized to choose from (which there most likely will not be!), would it be safer to choose a higher-value resistor or a lower-value resistor for these applications? For example, if you needed 670 Ω but the closest options on hand were 680 Ω and 500 Ω , which resistance value would you select? Explain your answer.

Notes 29

If students are not yet familiar with the "+V" symbol used to denote the positive power supply connection in this schematic, let them know that this is a very common practice in electronic notation, just as it is common to use the ground symbol as a power supply connection symbol.

The follow-up question is a very practical one, for it is seldom that you have the exact components on-hand to match the requirements of a circuit you are building. It is important to understand which way is safer to err (too large or too small) when doing "as-built" design work.

Question 30

Complete the table of values for this circuit:

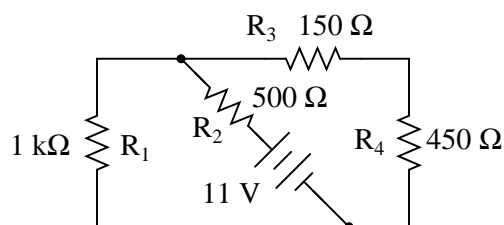

	R ₁	R ₂	R ₃	R ₄	Total
V					11 V
I					
R	1 kΩ	500 Ω	150 Ω	450 Ω	
P					

file 03257

Answer 30

	R ₁	R ₂	R ₃	R ₄	Total
V	4.714 V	6.286 V	1.179 V	3.536 V	11 V
I	4.714 mA	12.57 mA	7.857 mA	7.857 mA	12.57 mA
R	1 kΩ	500 Ω	150 Ω	450 Ω	875 Ω
P	22.22 mW	79.02 mW	9.26 mW	27.78 mW	138.3 mW

Notes 30

Discuss with your students what a good procedure might be for calculating the unknown values in this problem, and also how they might check their work.

Students often have difficulty formulating a method of solution: determining what steps to take to get from the given conditions to a final answer. While it is helpful at first for you (the instructor) to show them, it is bad for you to show them too often, lest they stop thinking for themselves and merely follow your lead. A teaching technique I have found very helpful is to have students come up to the board (alone or in teams) in front of class to write their problem-solving strategies for all the others to see. They don't have to actually do the math, but rather outline the steps they would take, in the order they would take them.

By having students outline their problem-solving strategies, everyone gets an opportunity to see multiple methods of solution, and you (the instructor) get to see how (and if!) your students are thinking. An especially good point to emphasize in these "open thinking" activities is how to check your work to see if any mistakes were made.

Question 31

Complete the table of values for this circuit:

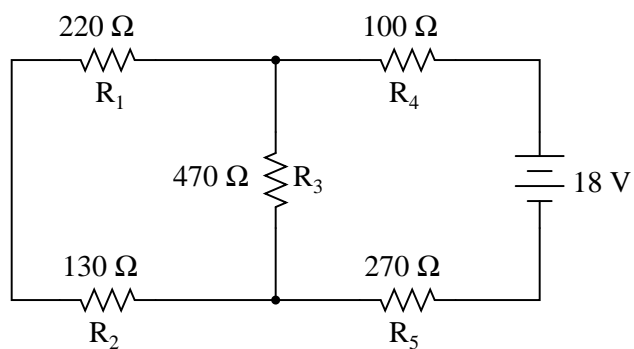

	R ₁	R ₂	R ₃	R ₄	R ₅	Total
V						
I						
R	220 Ω	130 Ω	470 Ω	100 Ω	270 Ω	
P						

[file 01767](#)

Answer 31

	R ₁	R ₂	R ₃	R ₄	R ₅	Total
V	3.978 V	2.351 V	6.328 V	3.155 V	8.517 V	18 V
I	18.08 mA	18.08 mA	13.46 mA	31.55 mA	31.55 mA	31.55 mA
R	220 Ω	130 Ω	470 Ω	100 Ω	270 Ω	570.6 Ω
P	71.92 mW	42.50 mW	85.21 mW	99.51 mW	268.7 mW	567.8 mW

Notes 31

Discuss with your students what a good procedure might be for calculating the unknown values in this problem, and also how they might check their work.

Question 32

Complete the table of values for this circuit:

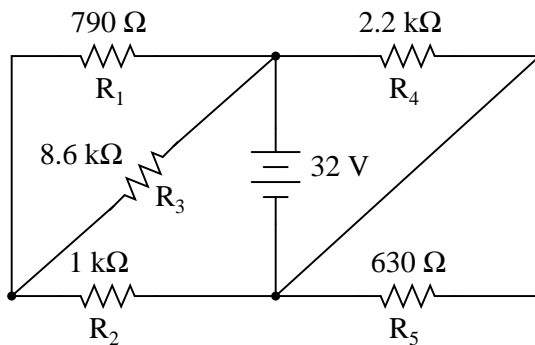

	R ₁	R ₂	R ₃	R ₄	R ₅	Total
V						
I						
R	790 Ω	1 kΩ	8.6 kΩ	2.2 kΩ	630 Ω	
P						

file 01768

Answer 32

	R ₁	R ₂	R ₃	R ₄	R ₅	Total
V	13.43 V	18.57 V	13.43 V	32 V	0 V	32 V
I	17.00 mA	18.57 mA	1.562 mA	14.55 mA	0 mA	33.11 mA
R	790 Ω	1 kΩ	8.6 kΩ	2.2 kΩ	630 Ω	966.4 Ω
P	228.4 mW	344.7 mW	20.98 mW	465.5 mW	0 mW	1.06 W

Challenge question: what circuit parameters will change if the diagonal wire in the right-hand side of the circuit is cut?

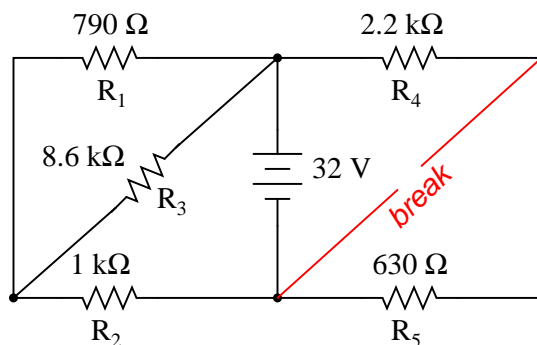

Discuss with your students what a good procedure might be for calculating the unknown values in this problem, and also how they might check their work.

Question 33

Complete the table of values for this circuit:

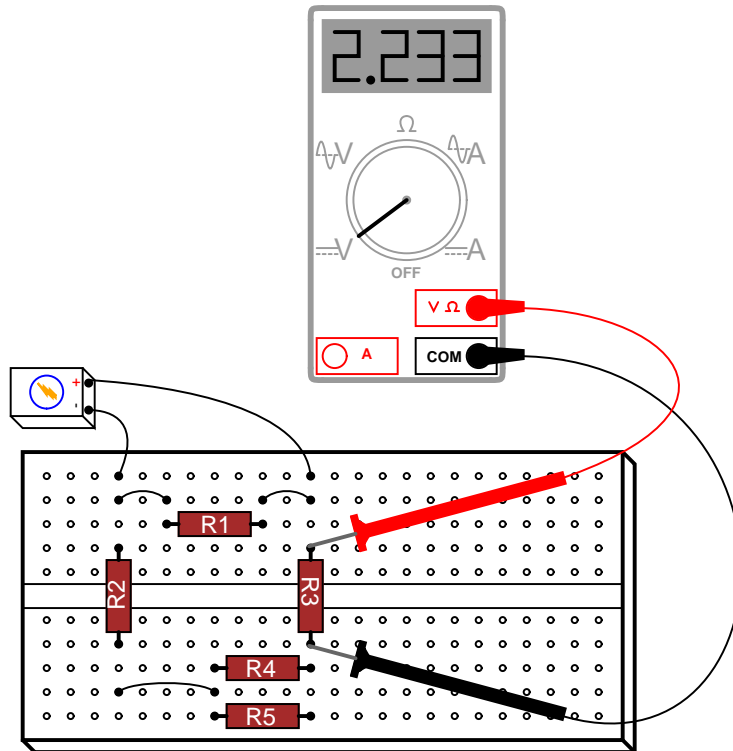

	R ₁	R ₂	R ₃	R ₄	R ₅	Total
V						
I						
R	2 kΩ	1 kΩ	3.3 kΩ	4.7 kΩ	4.7 kΩ	
P						

[file 01769](#)

Answer 33

	R ₁	R ₂	R ₃	R ₄	R ₅	Total
V	4.500 V	676.6 mV	2.233 V	1.590 V	1.590 V	4.500 V
I	2.250 mA	676.7 μA	676.7 μA	338.3 μA	338.3 μA	2.927 mA
R	2 kΩ	1 kΩ	3.3 kΩ	4.7 kΩ	4.7 kΩ	1.538 kΩ
P	10.12 mW	457.9 μW	1.511 mW	538.0 μW	538.0 μW	13.17 mW

Ask your students to identify components in this series-parallel circuit that are guaranteed to share the same voltage, and components that are guaranteed to share the same current, without reference to any calculations. This is a good exercise in identifying parallel and series interconnections, respectively.

Students often have difficulty formulating a method of solution: determining what steps to take to get from the given conditions to a final answer. While it is helpful at first for you (the instructor) to show them, it is bad for you to show them too often, lest they stop thinking for themselves and merely follow your lead. A teaching technique I have found very helpful is to have students come up to the board (alone or in teams) in front of class to write their problem-solving strategies for all the others to see. They don't have to actually do the math, but rather outline the steps they would take, in the order they would take them.

By having students outline their problem-solving strategies, everyone gets an opportunity to see multiple methods of solution, and you (the instructor) get to see how (and if!) your students are thinking. An especially good point to emphasize in these "open thinking" activities is how to check your work to see if any mistakes were made.

Question 34

What would happen to the voltage drops across each resistor in this circuit if resistor R1 were to fail open?

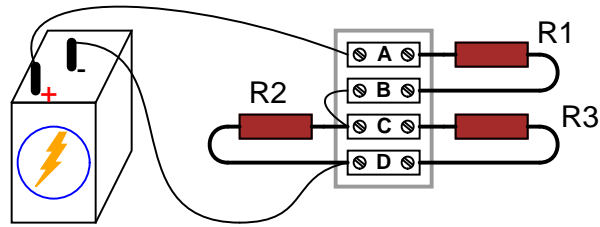

file 01771

Answer 34

If resistor R1 were to fail open (internally), it would drop the full battery voltage across its terminals, leaving no voltage for R2 or R3.

Notes 34

In most DC circuit failure scenarios, the effects of open or short faults may be estimated or even precisely predicted without having to perform any mathematical calculations. Of course, you could calculate the effects by using extremely large values for open resistors and 0 for shorted resistors, but that would be an inefficient use of time!

Question 35

What would happen to the voltage drops across each resistor in this circuit if either resistor R2 or R3 were to fail open?

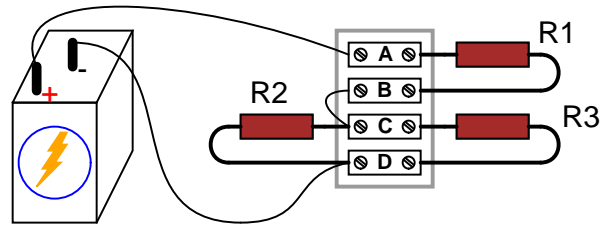

file 01772

Answer 35

If either resistor R2 or R3 were to fail open (internally), the voltage across both R2 *and* R3 would increase (but not to full battery voltage), leaving less voltage dropped across R1.

Follow-up question: explain why it doesn't matter which resistor (R2 or R3) fails open – the *qualitative* results for voltage (voltage increasing or decreasing, but not by any specific amount) will be the same.

Notes 35

I have found in teaching that many students loathe qualitative analysis, because they cannot let their calculators do the thinking for them. However, being able to judge whether a circuit parameter will increase, decrease, or remain the same after a component fault is an *essential* skill for proficient troubleshooting.

Question 36

What will happen to each resistor's voltage and current in this circuit if resistor R1 fails open? Provide individual answers for each resistor, please.

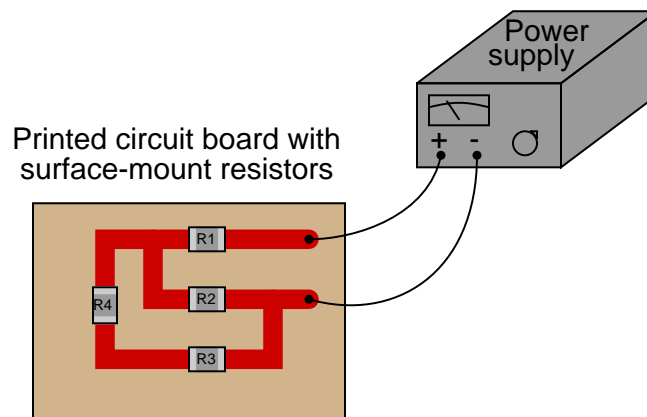

[file 01775](#)

Answer 36

If resistor R1 fails open . . .

- V_{R1} will increase to full supply voltage, I_{R1} will decrease to zero
- V_{R2} will decrease to zero, I_{R2} will decrease to zero
- V_{R3} will decrease to zero, I_{R3} will decrease to zero
- V_{R4} will decrease to zero, I_{R4} will decrease to zero

Follow-up question: note the order in which I list the qualitative effects of R2's shorted failure. Reading from the top of the list to the bottom reveals the sequence of my reasoning. Explain why I would come to the conclusions I did, in the order I did.

Notes 36

I have found in teaching that many students loathe qualitative analysis, because they cannot let their calculators do the thinking for them. However, being able to judge whether a circuit parameter will increase, decrease, or remain the same after a component fault is an *essential* skill for proficient troubleshooting.

Question 37

What will happen to each resistor's voltage and current in this circuit if resistor R2 fails shorted? Provide individual answers for each resistor, please.

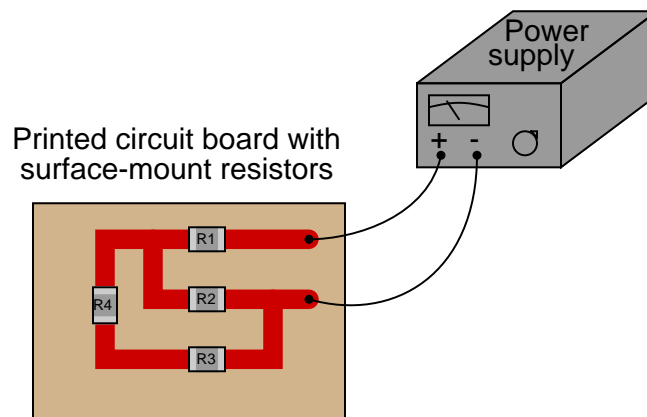

[file 01774](#)

Answer 37

If resistor R2 fails shorted . . .

- V_{R2} will decrease to zero, I_{R2} will increase
- V_{R1} will increase to full supply voltage, I_{R1} will increase
- V_{R3} will decrease to zero, I_{R3} will decrease to zero
- V_{R4} will decrease to zero, I_{R4} will decrease to zero

Follow-up question: note the order in which I list the qualitative effects of R2's shorted failure. Reading from the top of the list to the bottom reveals the sequence of my reasoning. Explain why I would come to the conclusions I did, in the order I did.

Notes 37

I have found in teaching that many students loathe qualitative analysis, because they cannot let their calculators do the thinking for them. However, being able to judge whether a circuit parameter will increase, decrease, or remain the same after a component fault is an *essential* skill for proficient troubleshooting.

Question 38

What will happen to each resistor's voltage in this circuit if resistor R4 fails shorted? Provide individual answers for each resistor, please.

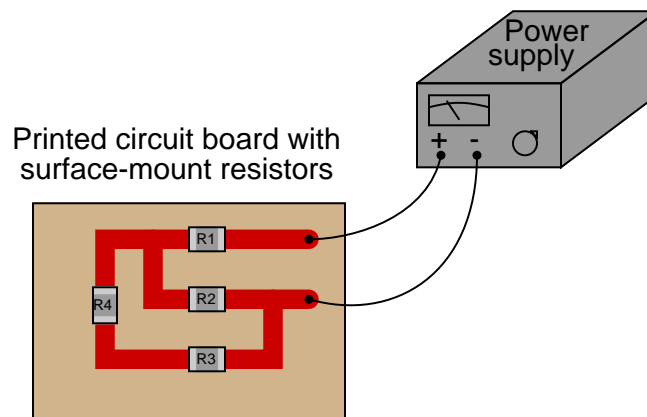

Also, comment on the practical likelihood of a resistor failing shorted, as opposed to failing open.
[file 01773](#)

Answer 38

If resistor R4 fails shorted . . .

- V_{R4} will decrease to zero
- V_{R1} will increase
- V_{R2} will decrease
- V_{R3} will increase

Follow-up question: resistors are actually far less likely to fail shorted as they are to fail *open*. However, this does not mean something else on a circuit board cannot go wrong to make it appear as though a resistor failed shorted! One example of such a fault is called a *solder bridge*. Explain what this is, any why it could produce the same effect as a resistor failing shorted.

Notes 38

I have found in teaching that many students loathe qualitative analysis, because they cannot let their calculators do the thinking for them. However, being able to judge whether a circuit parameter will increase, decrease, or remain the same after a component fault is an *essential* skill for proficient troubleshooting.

Question 39

A student built this resistor circuit on a solderless breadboard, but made a mistake positioning resistor R3. It should be located one hole to the left instead of where it is right now:

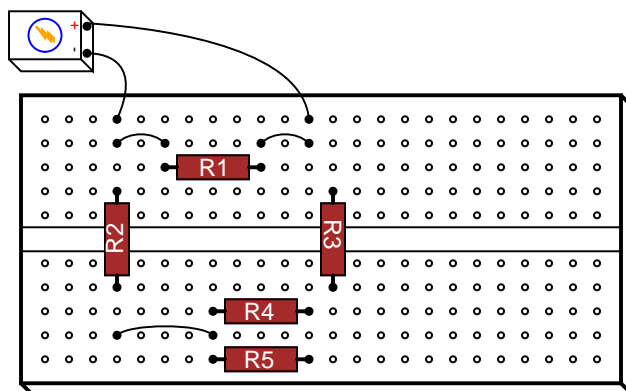

Determine what the voltage drop will be across each resistor, in this faulty configuration, assuming that the battery outputs 9 volts.

- $R_1 = 2 \text{ k}\Omega$ $V_{R1} =$
- $R_2 = 1 \text{ k}\Omega$ $V_{R2} =$
- $R_3 = 3.3 \text{ k}\Omega$ $V_{R3} =$
- $R_4 = 4.7 \text{ k}\Omega$ $V_{R4} =$
- $R_5 = 4.7 \text{ k}\Omega$ $V_{R5} =$

file 01770

Answer 39

Rather than tell you each voltage drop, I'll give you this one hint: there is only *one* resistor in this breadboard circuit that has voltage across it! All the other resistors in this circuit are de-energized, thanks to the misplacement of resistor R3.

Notes 39

Tell your students that the fault shown in this question is quite typical. The hole spacings on solderless breadboards are small enough that it is surprisingly easy to mis-locate a component in the manner shown.

Point out to your students (if they haven't already noticed) that no calculations are necessary to answer this question! It may be answered through simple, qualitative analysis alone.

Question 40

Calculate all voltages and currents in this circuit:

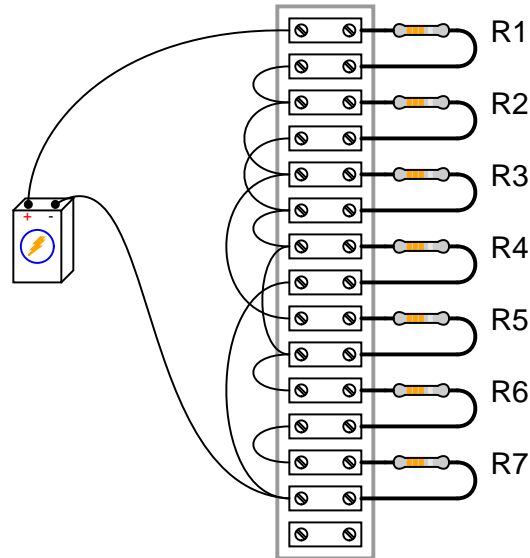

The battery voltage is 15 volts, and the resistor values are as follows:

- R1 = 1 k Ω
- R2 = 3.3 k Ω
- R3 = 4.7 k Ω
- R4 = 2.5 k Ω
- R5 = 10 k Ω
- R6 = 1.5 k Ω
- R7 = 500 Ω

file 00406

Answer 40

R1 = 1 k Ω	$E_{R1} = 4.016$ V	$I_{R1} = 4.016$ mA
R2 = 3.3 k Ω	$E_{R2} = 6.522$ V	$I_{R2} = 1.976$ mA
R3 = 4.7 k Ω	$E_{R3} = 6.522$ V	$I_{R3} = 1.388$ mA
R4 = 2.5 k Ω	$E_{R4} = 4.462$ V	$I_{R4} = 1.785$ mA
R5 = 10 k Ω	$E_{R5} = 6.522$ V	$I_{R5} = 652$ μ A
R6 = 1.5 k Ω	$E_{R6} = 3.347$ V	$I_{R6} = 2.231$ mA
R7 = 500 Ω	$E_{R7} = 1.116$ V	$I_{R7} = 2.231$ mA

Your students will benefit greatly from having a clean schematic diagram to work off of. However, do not supply this for them! Let them figure out how to derive a schematic diagram from the illustrated circuit.

Students often have difficulty formulating a method of solution: determining what steps to take to get from the given conditions to a final answer. While it is helpful at first for you (the instructor) to show them, it is bad for you to show them too often, lest they stop thinking for themselves and merely follow your lead. A teaching technique I have found very helpful is to have students come up to the board (alone or in teams) in front of class to write their problem-solving strategies for all the others to see. They don't have to actually do the math, but rather outline the steps they would take, in the order they would take them.

By having students outline their problem-solving strategies, everyone gets an opportunity to see multiple methods of solution, and you (the instructor) get to see how (and if!) your students are thinking. An especially good point to emphasize in these "open thinking" activities is how to check your work to see if any mistakes were made.

Don't just sit there! Build something!!

Learning to mathematically analyze circuits requires much study and practice. Typically, students practice by working through lots of sample problems and checking their answers against those provided by the textbook or the instructor. While this is good, there is a much better way.

You will learn much more by actually *building and analyzing real circuits*, letting your test equipment provide the "answers" instead of a book or another person. For successful circuit-building exercises, follow these steps:

1. Carefully measure and record all component values prior to circuit construction.
2. Draw the schematic diagram for the circuit to be analyzed.
3. Carefully build this circuit on a breadboard or other convenient medium.
4. Check the accuracy of the circuit's construction, following each wire to each connection point, and verifying these elements one-by-one on the diagram.
5. Mathematically analyze the circuit, solving for all values of voltage, current, etc.
6. Carefully measure those quantities, to verify the accuracy of your analysis.
7. If there are any substantial errors (greater than a few percent), carefully check your circuit's construction against the diagram, then carefully re-calculate the values and re-measure.

Avoid very high and very low resistor values, to avoid measurement errors caused by meter "loading". I recommend resistors between 1 k Ω and 100 k Ω , unless, of course, the purpose of the circuit is to illustrate the effects of meter loading!

One way you can save time and reduce the possibility of error is to begin with a very simple circuit and incrementally add components to increase its complexity after each analysis, rather than building a whole new circuit for each practice problem. Another time-saving technique is to re-use the same components in a variety of different circuit configurations. This way, you won't have to measure any component's value more than once.

[file 00405](#)

Let the electrons themselves give you the answers to your own "practice problems"!

It has been my experience that students require much practice with circuit analysis to become proficient. To this end, instructors usually provide their students with lots of practice problems to work through, and provide answers for students to check their work against. While this approach makes students proficient in circuit theory, it fails to fully educate them.

Students don't just need mathematical practice. They also need real, hands-on practice building circuits and using test equipment. So, I suggest the following alternative approach: students should *build* their own "practice problems" with real components, and try to mathematically predict the various voltage and current values. This way, the mathematical theory "comes alive," and students gain practical proficiency they wouldn't gain merely by solving equations.

Another reason for following this method of practice is to teach students *scientific method*: the process of testing a hypothesis (in this case, mathematical predictions) by performing a real experiment. Students will also develop real troubleshooting skills as they occasionally make circuit construction errors.

Spend a few moments of time with your class to review some of the "rules" for building circuits before they begin. Discuss these issues with your students in the same Socratic manner you would normally discuss the worksheet questions, rather than simply telling them what they should and should not do. I never cease to be amazed at how poorly students grasp instructions when presented in a typical lecture (instructor monologue) format!

A note to those instructors who may complain about the "wasted" time required to have students build real circuits instead of just mathematically analyzing theoretical circuits:

What is the purpose of students taking your course?

If your students will be working with real circuits, then they should learn on real circuits whenever possible. If your goal is to educate theoretical physicists, then stick with abstract analysis, by all means! But most of us plan for our students to do something in the real world with the education we give them. The "wasted" time spent building real circuits will pay huge dividends when it comes time for them to apply their knowledge to practical problems.

Furthermore, having students build their own practice problems teaches them how to perform *primary research*, thus empowering them to continue their electrical/electronics education autonomously.

In most sciences, realistic experiments are much more difficult and expensive to set up than electrical circuits. Nuclear physics, biology, geology, and chemistry professors would just love to be able to have their students apply advanced mathematics to real experiments posing no safety hazard and costing less than a textbook. They can't, but you can. Exploit the convenience inherent to your science, and *get those students of yours practicing their math on lots of real circuits!*