

Insulated gate bipolar transistors

This worksheet and all related files are licensed under the Creative Commons Attribution License, version 1.0. To view a copy of this license, visit <http://creativecommons.org/licenses/by/1.0/>, or send a letter to Creative Commons, 559 Nathan Abbott Way, Stanford, California 94305, USA. The terms and conditions of this license allow for free copying, distribution, and/or modification of all licensed works by the general public.

Resources and methods for learning about these subjects (list a few here, in preparation for your research):

Questions

Question 1

What is an *Insulated Gate Bipolar Transistor* (IGBT), and what advantages does the IGBT provide over both power MOSFET and traditional BJT devices?

[file 01191](#)

Question 2

Complete the schematic diagram showing an equivalent circuit for an N-channel IGBT, using an N-channel E-type MOSFET and a PNP bipolar transistor:

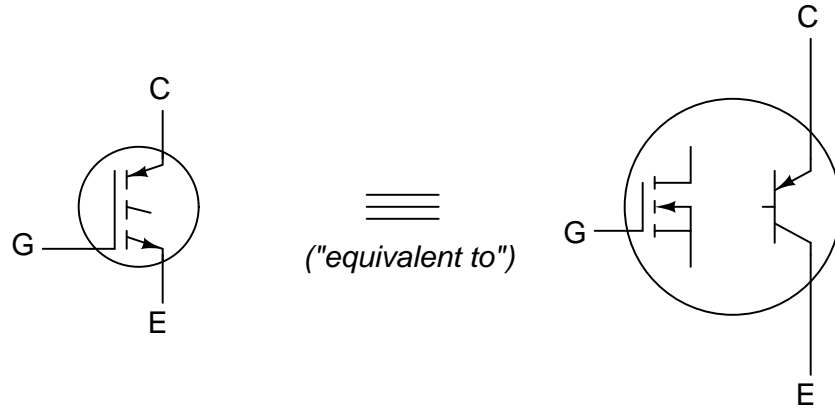

[file 02065](#)

Question 3

The equivalent circuit for an IGBT – comprised of a MOSFET coupled to a BJT – bears resemblance to a couple of other BJT circuits you may have seen before:

Darlington pair

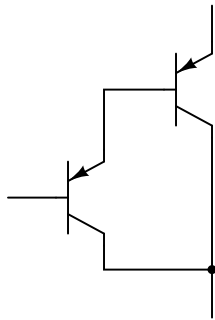

Sziklai pair

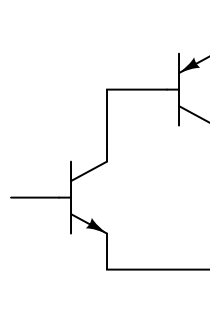

Which of these two paired-BJT circuits most resembles the IGBT equivalent circuit, in terms of what two terminals the control signal voltage must be applied between to turn the device on?

[file 02066](#)

Question 4

Draw a complete schematic diagram showing how this IGBT can be used to control a DC motor, at the command of the toggle switch:

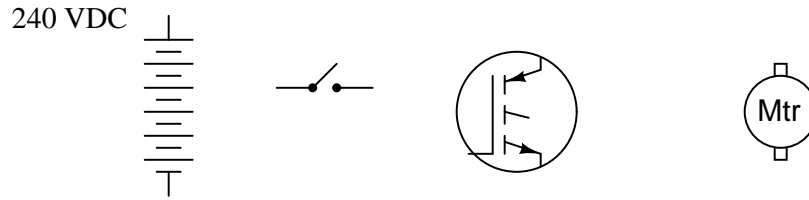

Note: the DC power supply voltage is 240 VDC, and the IGBT's maximum gate-to-emitter control voltage is 20 volts!

[file 01192](#)

Question 5

Examine the schematic diagram for this photographic strobe light control system:

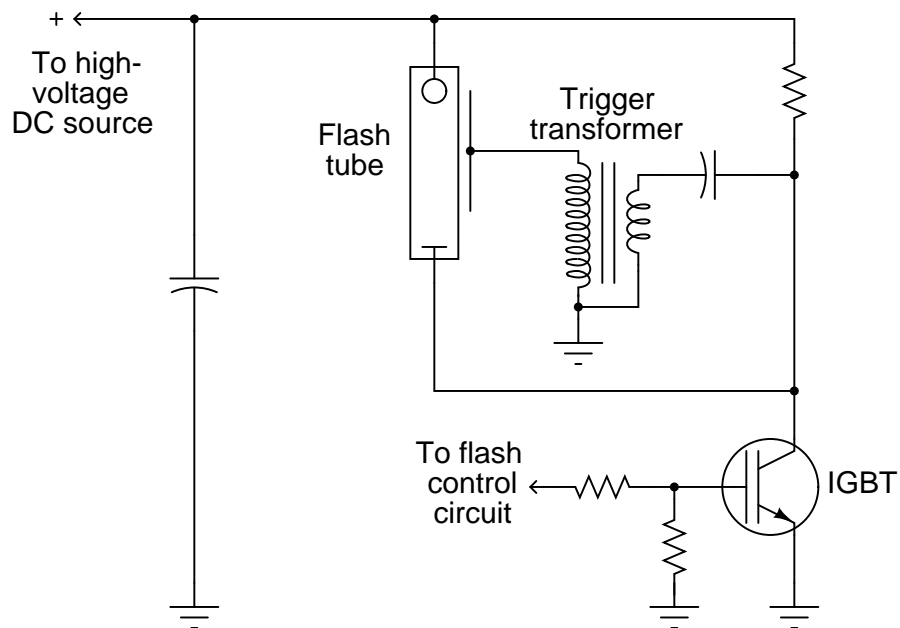

Explain its operation, and explain why an IGBT is a good transistor type for this application.
[file 02127](#)

Answers

Answer 1

The IGBT is a hybrid device, combining the best attributes of MOSFET and BJT in a single component.

Follow-up question: describe some typical applications for the IGBT which make use of these advantages.

Answer 2

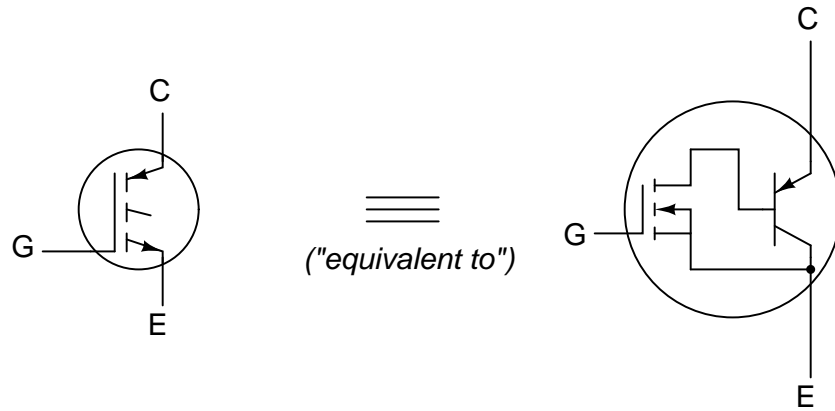

Answer 3

The Sziklai pair most resembles the IGBT equivalent circuit.

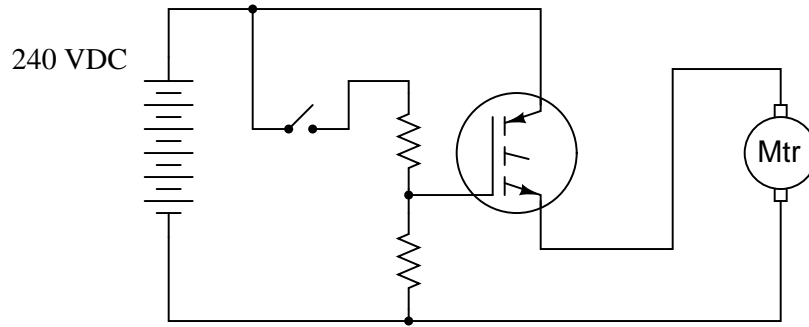

Follow-up question: calculate the values necessary for the two resistors shown, to provide a gate-to-emitter voltage of 10 volts, using 1/2 watt resistors.

Challenge question: why might it be a good idea to include a diode in the circuit, like this?

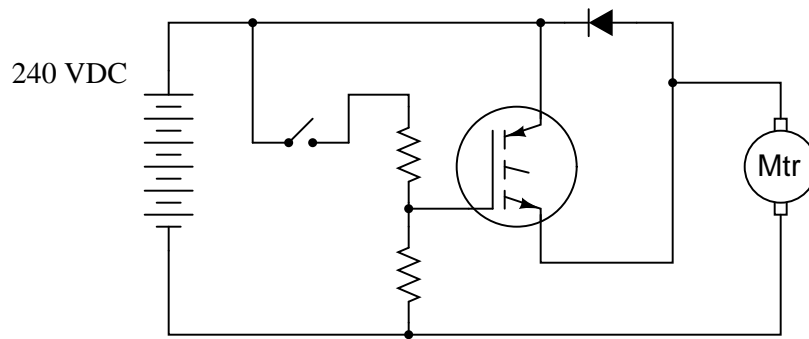

When the IGBT is turned on, the "trigger" transformer develops a high voltage pulse on the flash tube's trigger wire, ionizing the xenon gas within and allowing a surge of current to pass between the tube's main electrodes. Since the IGBT handles the tube's main current as well, it is able to turn off the strobe as easily as it turned it on.

Notes

Notes 1

The given answer is accurate, yet not very specific. Ask your students to explain exactly what attributes of MOSFET and BJT are exhibited by the IGBT, and why.

Notes 2

You should discuss with your students the fact that IGBT's are not actually made of two discrete transistors connected as shown. Instead, they are fabricated as monolithic devices, all on the same semiconductor substrate. The "model" of an IGBT consisting of a MOSFET coupled to a BJT is similar to the model commonly used to emulate an SCR: a circuit whose sole purpose it is to show the operation of a special device in terms of other, well-understood devices.

Notes 3

It is important for students to realize what two terminals of the device the input (control) signal must be applied to in order to turn the device on. This is really the point of the question, not so much a review of Darlington versus Sziklai pairs.

Notes 4

Ask your students what purpose the voltage divider serves. The first purpose should be obvious, as hinted in the "Note" at the end of the question. However, a second purpose is not so obvious. If the lower resistor were to fail open, the IGBT would turn on when the switch closes, but it would not turn off (at least not reliably) when the switch opens! Present this scenario to your students, and ask them to explain why this would happen.

Check your students' math when they present resistor values. Do not be surprised if some students specify the resistor values such that the actual power dissipation runs right at 1/2 watt each! Use this as an opportunity to discuss component reliability versus power dissipation, and good engineering practices.

Regarding the challenge question, the diode is *not* there to provide a path for inductive "free-wheeling" current. Some of your students may suggest this as its purpose, but a close examination of polarity will show otherwise. The true answer to this question, in the context of a DC motor control circuit, has to do with the behavior of DC motors.

Notes 5

Even if students have never seen a strobe light circuit, they should at least be able to determine what happens when the transistor is immediately turned "on." The fact that professional flash tubes require currents in excess of a hundred amps is not obvious from this schematic, so you should mention this fact in the discussion.

This schematic was adapted (simplified) from one found in a Fairchild IGBT application note (AN9006 – "IGBT Application Note For Camera Strobe").