

## Design Project: AC-DC power supply

This worksheet and all related files are licensed under the Creative Commons Attribution License, version 1.0. To view a copy of this license, visit <http://creativecommons.org/licenses/by/1.0/>, or send a letter to Creative Commons, 559 Nathan Abbott Way, Stanford, California 94305, USA. The terms and conditions of this license allow for free copying, distribution, and/or modification of all licensed works by the general public.

---

Your project is to design and build an AC-to-DC "brute force" power supply, complete with filtering to minimize ripple. The power supply will output a DC voltage somewhere between 12 and 24 volts DC, at a maximum current of 1 amp, and will contain overcurrent protection on both the AC (line) and DC (load) sides. As a line-powered device, it will also be equipped with an indicator light showing the presence of AC voltage, and the case (if metal) will be safety grounded. Here is a sample schematic diagram for you to follow when designing your system:

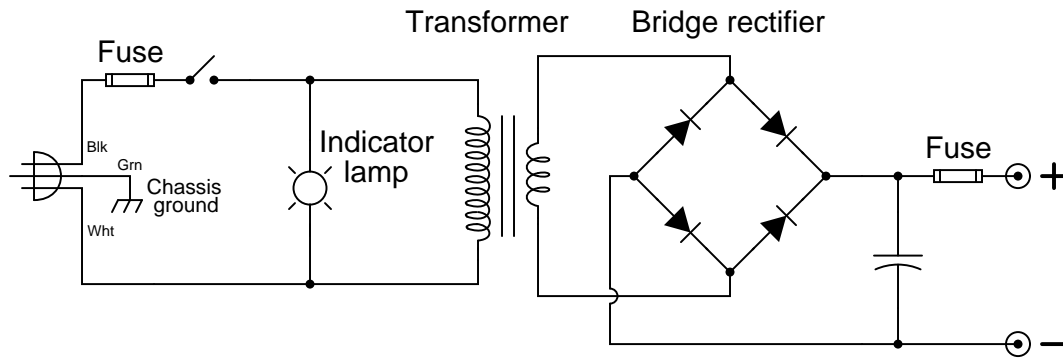

Of course, you are not restricted to using this exact design. One design feature I insist on, though, is that you build your own rectifier circuit from individual diodes, rather than use a packaged rectifier assembly. I highly recommend the use of "barrier strips" or "terminal strips" to make the electrical connections between components. These connection devices provide solid, permanent electrical connections while still allowing components to be easily installed and removed.

I also insist on the AC power cord being securely and safely attached to the case. One of the best ways of doing this is to use a "cord grip bushing" or "CGB" to firmly secure the cord as it passes through a hole in the side of the case. Most hardware stores carry this common electrical fitting, in enough different sizes to accommodate most any power cord diameter.

All final versions of the power supply must be safety-checked before plugging them into line (AC) power. The safety check will consist of the following points:

1. Ground prong to (metal) case resistance check – use a *Kelvin 4-wire test configuration* to measure voltage drop between the prong and case while the ground conductor is carrying at least a 1-amp current (from a benchtop power supply configured as a current source). Total ground path resistance from prong to case shall not exceed 0.1 ohm (100 mV drop at 1 amp).
2. Hot-to-neutral continuity measurement to check for proper operation of power switch and AC fuse.
3. Hot-to-ground and neutral-to-ground continuity measurements to ensure isolation from chassis ground.
4. Transformer secondary-to-positive output continuity measurement to check for proper operation of DC fuse.

Deadlines (set by instructor):

- Project design completed:
- Components purchased:
- Working prototype:
- Finished system:
- Full documentation:

## Questions

---

### Question 1

Safety is very important when designing and/or building a device powered by potentially lethal electrical sources such as residential AC line power. Explain how you can *prove* that the metal case of your power supply is indeed "grounded" for safety, such that an internal fault from one of the "hot" conductors to the metal case will result in a short-circuit that will trip the power receptacle's fuse or breaker rather than shock the individual touching the case?

Hint: a visual inspection is not good enough, and we don't want to actually create a ground fault situation to test the grounding.

[file 01505](#)

---

### Question 2

When connecting components together to build your power supply, it is important that you use the proper type(s) of wire. Identify what characteristics are required for the wires you use in this project, for each of the following parameters:

- Wire gauge:
- Insulation type:
- Stranding (solid or stranded):

[file 01509](#)

---

### Question 3

How do we tell which winding of the step-down power transformer is the primary, and which is the secondary, without actually powering it up with AC line power? This is often an issue when students purchase cheap transformers that are unmarked and undocumented.

[file 01506](#)

---

### Question 4

When you measure the low-voltage AC output of your transformer and compare that measurement to the rectified and filtered DC output voltage, you will notice something very counter-intuitive. The DC output voltage reading is substantially *greater* than the unrectified AC voltage from the transformer's secondary winding!

Explain why this is, and then show mathematical calculations that relate the two voltage measurements together with reasonable accuracy.

[file 01507](#)

---

### Question 5

One thing you will want to do with your completed power supply is subject it to a full-current (1 amp) load, and test the output voltage. To do this, you will need a load that draws close to 1 amp without overheating or causing other problems.

A resistor will work fine for this task, but which resistor should you use? Identify the *two* parameters you must be concerned about when selecting a load resistor for the task, and explain exactly how those parameters will be calculated.

[file 01508](#)

---

## Answers

---

### Answer 1

Measure resistance from the ground prong on the power plug to the metal case. The resistance should be no more than a few tenths of an ohm. A resistance measurement of 0.5 ohm or more indicates a poor connection.

---

### Answer 2

- Wire gauge: *sufficient for the maximum current expected*
- Insulation type: *sufficient for the maximum voltage expected*
- Stranding (solid or stranded): *stranded preferred*

For the first two parameters, identify the values of expected current and voltage to be encountered in your power supply circuit, for both the AC and the DC sections.

Why do you suppose stranded wire might be preferred for a project such as this? I'll give you a hint: it is not for any *electrical* property of the wire as much as it is for *mechanical* considerations.

---

### Answer 3

Use an ohmmeter to measure the resistance of each winding. The primary winding of a step-down transformer will contain a longer length of wire, of smaller cross-sectional area, than the secondary winding. With these two factors, the resistance difference between windings should be obvious.

---

### Answer 4

This is something that catches almost all students by surprise when they first measure the voltages. I'll give you a big hint why the rectified and filtered (DC) output voltage is so much greater than the unrectified (AC) secondary voltage: the AC voltage measurement you make with your voltmeter is most likely an *RMS* measurement, not a *peak* measurement.

---

### Answer 5

The two parameters are: *resistance* (how many ohms), and *power rating* (how many watts). I will leave it to you to show how to calculate each parameter for your particular power supply.

### Notes 1

As a general policy, I inspect each and every one of my students' power supplies before energizing for the first time. This does not mean, though, that I am the one making the meter measurements! Each student must prove to me that their grounding is adequate by making the meter measurement under my direct supervision. This way, they learn how to do it themselves while safety is still personally ensured by me.

I also have the students tug on the wire connections while making this test, to ensure that it is not a *random* low-resistance measurement we are seeing with the ohmmeter. Loose wire connections are best tested by resistance measurements under mechanical stress, not by visual inspection alone.

---

### Notes 2

Ampacity figures may not be readily available for wires of the gauge most electronics students are accustomed to dealing with. However, ampacity for small-gauge wire may be roughly calculated by plotting data points of published wire ampacities for wire of several larger gauges, and then extrapolating downward on the gauge scale. If nothing else, this would be a great example to students of how to use simple statistical techniques (regression, curve fitting, plotting) to make practical estimations.

---

### Notes 3

Care should be taken if the transformer in question is a complete unknown. It may be impossible to tell what the respective voltage ratings of the windings are if one does not even know whether the transformer was designed for line power (120 volts, 60 Hz AC in the United States) or not. Small power transformers are easy enough to obtain from electronics parts suppliers and from scrap consumer electronic devices (stereos, computer accessories, etc.) that no one should have to take chances with a completely unknown transformer.

---

### Notes 4

Let students figure out this mystery on their own: it is one of those phenomena that really reveals the nature of RMS measurements in contrast to peak measurements.

---

### Notes 5

Even though this is nothing more than an application of Ohm's Law, do not be surprised if students approach you dumbfounded by this question. There is a large cognitive difference between calculating current and power for a resistor of known value and a voltage source of known voltage, and selecting a resistor based on known current and voltage for a practical test of a power supply. While studying Ohm's Law in a theoretical context, students become comfortable making calculations on paper, but may not realize just how to apply that same math to a real-world situation. Or, they may express apprehension when faced with having to make calculations that carry real consequences (such as damaging their power supply!).