

## Fault analysis of simple circuits

This worksheet and all related files are licensed under the Creative Commons Attribution License, version 1.0. To view a copy of this license, visit <http://creativecommons.org/licenses/by/1.0/>, or send a letter to Creative Commons, 559 Nathan Abbott Way, Stanford, California 94305, USA. The terms and conditions of this license allow for free copying, distribution, and/or modification of all licensed works by the general public.

## Questions

---

### Question 1

Everything I know about troubleshooting, I learned from Tyler Durden (with respects to the movie *Fight Club*):

#### **The Rules of Fault Club**

- (1) Don't try to find the fault by looking for it – perform diagnostic tests instead
- (1) *Don't try to find the fault by looking for it – perform diagnostic tests instead!*
- (3) The troubleshooting is over when you have correctly identified the nature and location of the fault
- (4) It's just you and the fault – don't ask for help until you have exhausted your resources
- (5) Assume one fault at a time in a proven system, unless the data proves otherwise
- (6) No new components allowed – replacing suspected bad components with new is a waste of time and money
- (7) We will practice as many times as we have to until you master this
- (8) Troubleshooting is not a spectator sport: *you* have to troubleshoot!

For each of these rules, explain their rationale.

file i01203

---

### Question 2

Identify which of these are true statements:

1. Between two points that are electrically common to each other, there is guaranteed to be zero (or nearly zero) voltage.
2. If zero voltage is measured between two points, those points must be electrically common to each other.
3. Between two points that are not electrically common to each other, there is guaranteed to be voltage.
4. If voltage is measured between two points, those points cannot be electrically common to each other.

file 01935

Question 3

Suppose the lamp refuses to light up when the pushbutton switch is pressed. A voltmeter registers 0 volts between test points **A** and **D** in the circuit while the pushbutton is pressed:

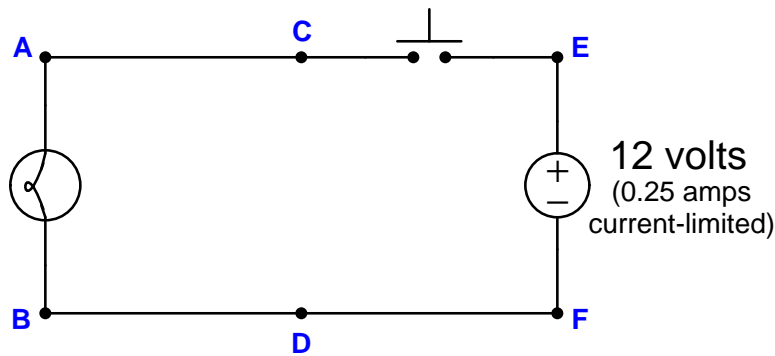

Identify the likelihood of each specified fault for this circuit. Consider each fault one at a time (i.e. no coincidental faults), determining whether or not each fault could independently account for *all* measurements and symptoms in this circuit.

Fault	Possible	Impossible
Open wire between A and C		
Open wire between B and D		
Open wire between D and F		
Lamp failed open		
Switch failed open		
Lamp failed shorted		
Switch failed shorted		
Voltage source dead		

Finally, identify the *next* diagnostic test or measurement you would make on this system. Explain how the result(s) of this next test or measurement help further identify the location and/or nature of the fault.

Question 4

Suppose the lamp refuses to light up when the pushbutton switch is pressed. A voltmeter registers 0 volts between test points **E** and **D** in the circuit while the pushbutton is pressed:

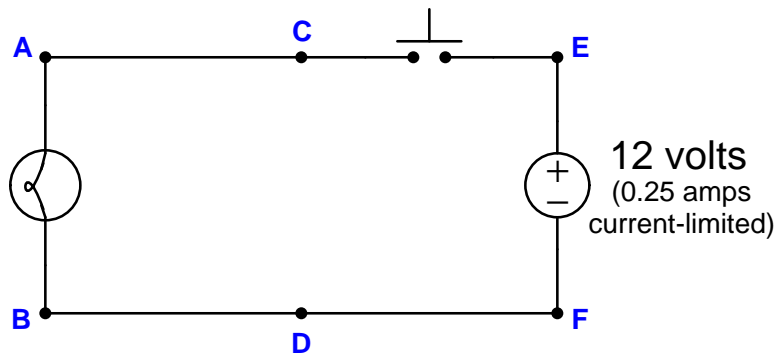

Identify the likelihood of each specified fault for this circuit. Consider each fault one at a time (i.e. no coincidental faults), determining whether or not each fault could independently account for *all* measurements and symptoms in this circuit.

Fault	Possible	Impossible
Open wire between A and C		
Open wire between B and D		
Open wire between D and F		
Lamp failed open		
Switch failed open		
Lamp failed shorted		
Switch failed shorted		
Voltage source dead		

Finally, identify the *next* diagnostic test or measurement you would make on this system. Explain how the result(s) of this next test or measurement help further identify the location and/or nature of the fault.

Question 5

Suppose the lamp refuses to light up when the pushbutton switch is pressed. A voltmeter registers 12 volts between test points **C** and **E** in the circuit while the pushbutton is released (not pressed):

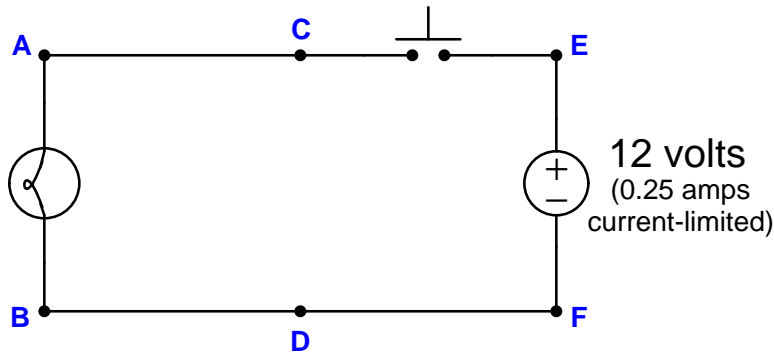

Identify the likelihood of each specified fault for this circuit. Consider each fault one at a time (i.e. no coincidental faults), determining whether or not each fault could independently account for *all* measurements and symptoms in this circuit.

Fault	Possible	Impossible
Open wire between A and C		
Open wire between B and D		
Open wire between D and F		
Lamp failed open		
Switch failed open		
Lamp failed shorted		
Switch failed shorted		
Voltage source dead		

Finally, identify the *next* diagnostic test or measurement you would make on this system. Explain how the result(s) of this next test or measurement help further identify the location and/or nature of the fault.

Question 6

Suppose a voltmeter registers 0 volts between test points **E** and **C** while the pushbutton is released (not pressed), and 0 volts between test points **B** and **D** while the pushbutton is pressed:

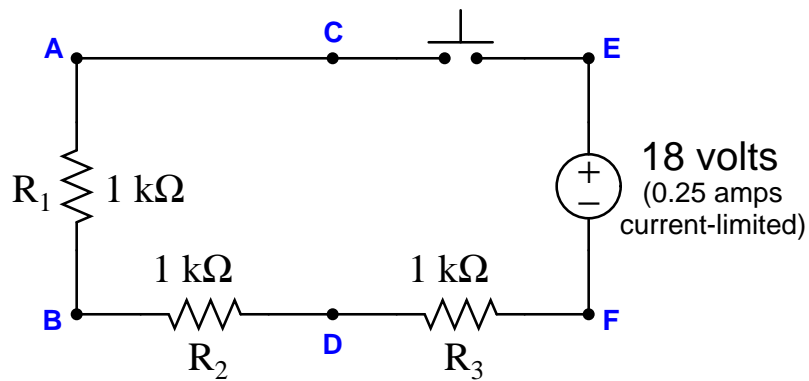

Identify the likelihood of each specified fault for this circuit. Consider each fault one at a time (i.e. no coincidental faults), determining whether or not each fault could independently account for *all* measurements and symptoms in this circuit.

Fault	Possible	Impossible
Switch failed open		
$R_1$ failed open		
$R_2$ failed open		
$R_3$ failed open		
Switch failed shorted		
$R_1$ failed shorted		
$R_2$ failed shorted		
$R_3$ failed shorted		
Voltage source dead		

Finally, identify the *next* diagnostic test or measurement you would make on this system. Explain how the result(s) of this next test or measurement help further identify the location and/or nature of the fault.

Question 7

Suppose a voltmeter registers 18 volts between test points **E** and **C** while the pushbutton is released (not pressed), and 0 volts between test points **A** and **B** while the pushbutton is pressed:

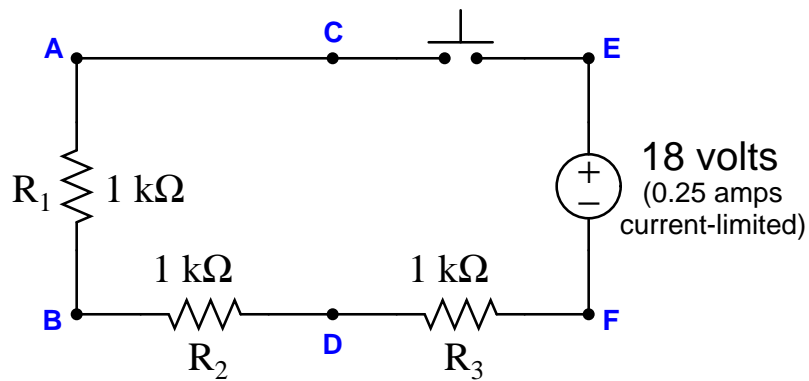

Identify the likelihood of each specified fault for this circuit. Consider each fault one at a time (i.e. no coincidental faults), determining whether or not each fault could independently account for *all* measurements and symptoms in this circuit.

Fault	Possible	Impossible
Switch failed open		
R <sub>1</sub> failed open		
R <sub>2</sub> failed open		
R <sub>3</sub> failed open		
Switch failed shorted		
R <sub>1</sub> failed shorted		
R <sub>2</sub> failed shorted		
R <sub>3</sub> failed shorted		
Voltage source dead		

Finally, identify the *next* diagnostic test or measurement you would make on this system. Explain how the result(s) of this next test or measurement help further identify the location and/or nature of the fault.

Question 8

Suppose a voltmeter registers 6 volts between test points **C** and **B** in this series-parallel circuit:

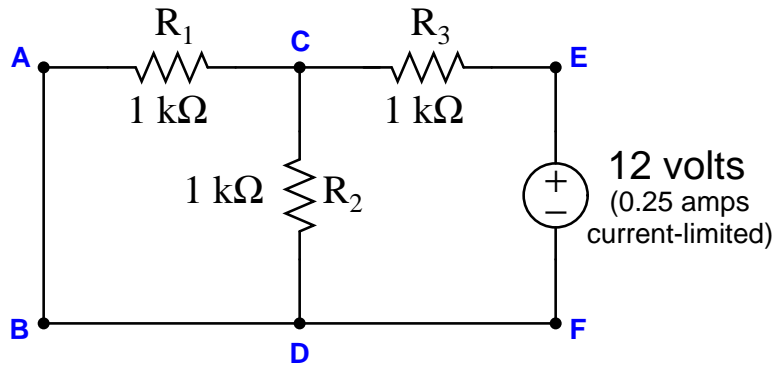

Identify the likelihood of each specified fault for this circuit. Consider each fault one at a time (i.e. no coincidental faults), determining whether or not each fault could independently account for *all* measurements and symptoms in this circuit.

Fault	Possible	Impossible
$R_1$ failed open		
$R_2$ failed open		
$R_3$ failed open		
$R_1$ failed shorted		
$R_2$ failed shorted		
$R_3$ failed shorted		
Voltage source dead		

Finally, identify the *next* diagnostic test or measurement you would make on this system. Explain how the result(s) of this next test or measurement help further identify the location and/or nature of the fault.



Question 9

Suppose a voltmeter registers 12 volts between test points C and D in this series-parallel circuit:

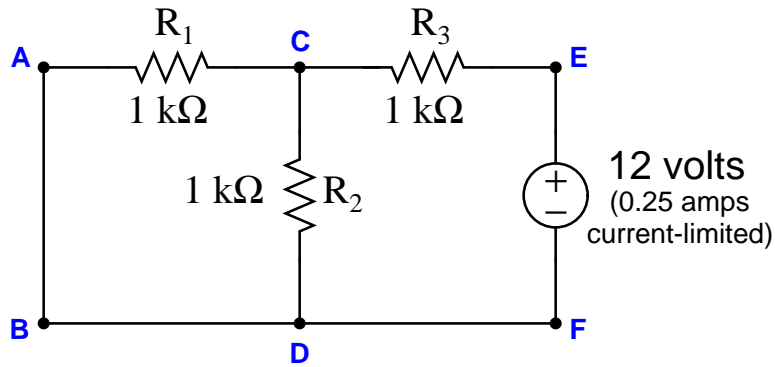

Identify the likelihood of each specified fault for this circuit. Consider each fault one at a time (i.e. no coincidental faults), determining whether or not each fault could independently account for *all* measurements and symptoms in this circuit.

Fault	Possible	Impossible
$R_1$ failed open		
$R_2$ failed open		
$R_3$ failed open		
$R_1$ failed shorted		
$R_2$ failed shorted		
$R_3$ failed shorted		
Voltage source dead		

Finally, explain why no further diagnostic tests or measurements are necessary to identify the location and nature of the fault.

Question 10

Suppose a voltmeter registers 0 volts between test points **C** and **F** in this series-parallel circuit:

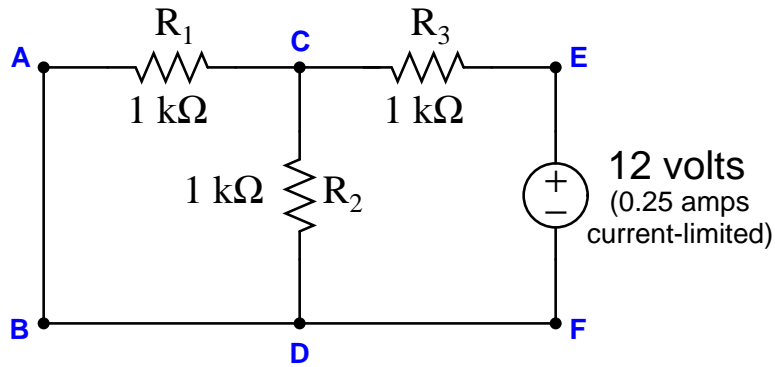

Identify the likelihood of each specified fault for this circuit. Consider each fault one at a time (i.e. no coincidental faults), determining whether or not each fault could independently account for *all* measurements and symptoms in this circuit.

Fault	Possible	Impossible
$R_1$ failed open		
$R_2$ failed open		
$R_3$ failed open		
$R_1$ failed shorted		
$R_2$ failed shorted		
$R_3$ failed shorted		
Voltage source dead		

Finally, identify the *next* diagnostic test or measurement you would make on this system. Explain how the result(s) of this next test or measurement help further identify the location and/or nature of the fault.

Question 11

Suppose a voltmeter registers 6 volts between test points **E** and **C** in this series-parallel circuit:

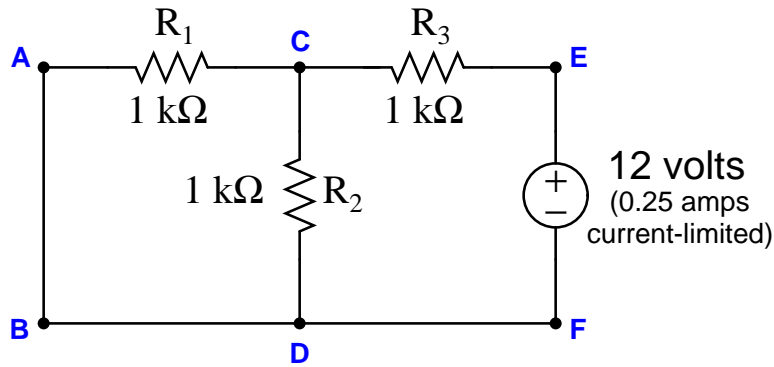

Identify the likelihood of each specified fault for this circuit. Consider each fault one at a time (i.e. no coincidental faults), determining whether or not each fault could independently account for *all* measurements and symptoms in this circuit.

Fault	Possible	Impossible
$R_1$ failed open		
$R_2$ failed open		
$R_3$ failed open		
$R_1$ failed shorted		
$R_2$ failed shorted		
$R_3$ failed shorted		
Voltage source dead		

Finally, identify the *next* diagnostic test or measurement you would make on this system. Explain how the result(s) of this next test or measurement help further identify the location and/or nature of the fault.

Question 12

Suppose an ammeter inserted between test point C and the nearest lead of resistor  $R_1$  registers 0 mA in this series-parallel circuit:

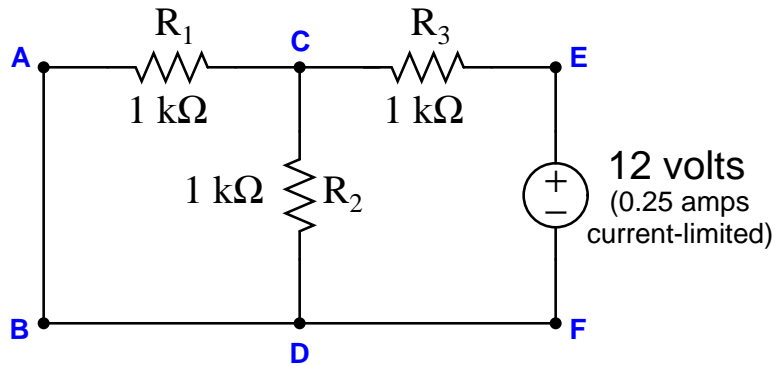

Identify the likelihood of each specified fault for this circuit. Consider each fault one at a time (i.e. no coincidental faults), determining whether or not each fault could independently account for *all* measurements and symptoms in this circuit.

Fault	Possible	Impossible
$R_1$ failed open		
$R_2$ failed open		
$R_3$ failed open		
$R_1$ failed shorted		
$R_2$ failed shorted		
$R_3$ failed shorted		
Voltage source dead		

Finally, identify the *next* diagnostic test or measurement you would make on this system. Explain how the result(s) of this next test or measurement help further identify the location and/or nature of the fault.

Question 13

Suppose an ammeter inserted between test point C and the nearest lead of resistor  $R_3$  registers 4 mA in this series-parallel circuit:

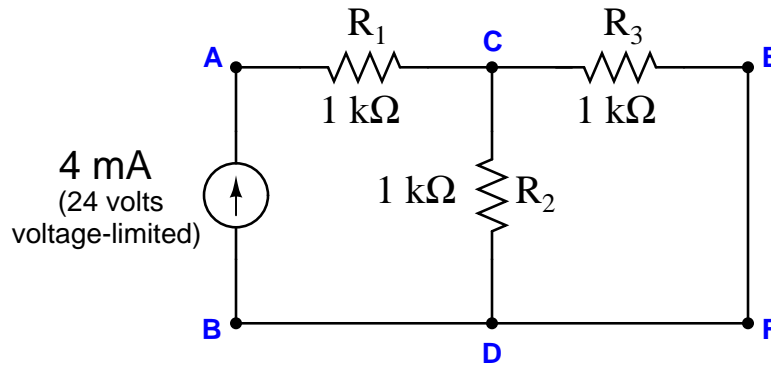

Identify the likelihood of each specified fault for this circuit. Consider each fault one at a time (i.e. no coincidental faults), determining whether or not each fault could independently account for *all* measurements and symptoms in this circuit.

Fault	Possible	Impossible
$R_1$ failed open		
$R_2$ failed open		
$R_3$ failed open		
$R_1$ failed shorted		
$R_2$ failed shorted		
$R_3$ failed shorted		
Current source dead		

Finally, identify the *next* diagnostic test or measurement you would make on this system. Explain how the result(s) of this next test or measurement help further identify the location and/or nature of the fault.

Question 14

Suppose an ammeter inserted between test point **D** and the nearest lead of resistor  $R_2$  registers 0 mA in this series-parallel circuit:

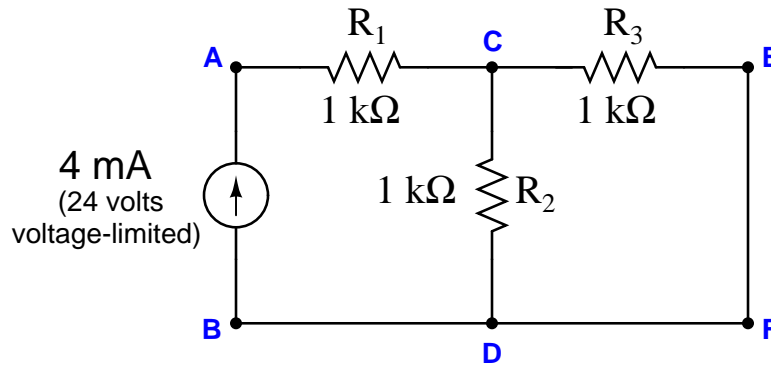

Identify the likelihood of each specified fault for this circuit. Consider each fault one at a time (i.e. no coincidental faults), determining whether or not each fault could independently account for *all* measurements and symptoms in this circuit.

Fault	Possible	Impossible
$R_1$ failed open		
$R_2$ failed open		
$R_3$ failed open		
$R_1$ failed shorted		
$R_2$ failed shorted		
$R_3$ failed shorted		
Current source dead		

Finally, identify the *next* diagnostic test or measurement you would make on this system. Explain how the result(s) of this next test or measurement help further identify the location and/or nature of the fault.

Question 15

Suppose a voltmeter registers 8 volts between test points **A** and **F** in this series-parallel circuit:

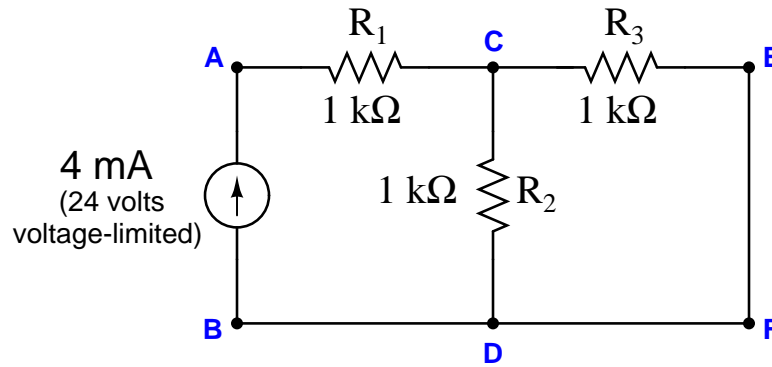

Identify the likelihood of each specified fault for this circuit. Consider each fault one at a time (i.e. no coincidental faults), determining whether or not each fault could independently account for *all* measurements and symptoms in this circuit.

Fault	Possible	Impossible
$R_1$ failed open		
$R_2$ failed open		
$R_3$ failed open		
$R_1$ failed shorted		
$R_2$ failed shorted		
$R_3$ failed shorted		
Current source dead		

Finally, identify the *next* diagnostic test or measurement you would make on this system. Explain how the result(s) of this next test or measurement help further identify the location and/or nature of the fault.

Question 16

Suppose an ammeter inserted between test points **E** and **C** registers 6 mA in this series-parallel circuit:

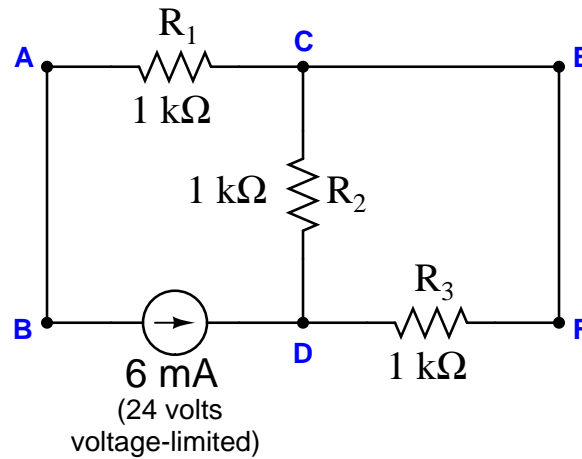

Identify the likelihood of each specified fault for this circuit. Consider each fault one at a time (i.e. no coincidental faults), determining whether or not each fault could independently account for *all* measurements and symptoms in this circuit.

Fault	Possible	Impossible
$R_1$ failed open		
$R_2$ failed open		
$R_3$ failed open		
$R_1$ failed shorted		
$R_2$ failed shorted		
$R_3$ failed shorted		
Current source dead		

Finally, identify the *next* diagnostic test or measurement you would make on this system. Explain how the result(s) of this next test or measurement help further identify the location and/or nature of the fault.  
[file i04456](#)



Question 17

Suppose a voltmeter registers 0 volts between test points **C** and **D** in this series-parallel circuit:

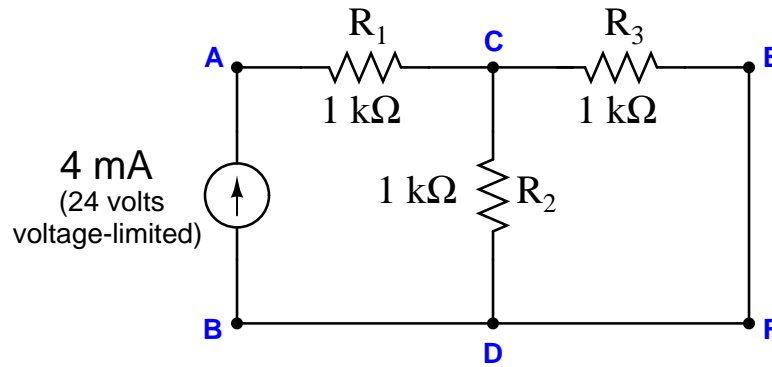

Identify the likelihood of each specified fault for this circuit. Consider each fault one at a time (i.e. no coincidental faults), determining whether or not each fault could independently account for *all* measurements and symptoms in this circuit.

Fault	Possible	Impossible
$R_1$ failed open		
$R_2$ failed open		
$R_3$ failed open		
$R_1$ failed shorted		
$R_2$ failed shorted		
$R_3$ failed shorted		
Current source dead		

Finally, identify the *next* diagnostic test or measurement you would make on this system. Explain how the result(s) of this next test or measurement help further identify the location and/or nature of the fault.

Question 18

Suppose an ammeter inserted between test points **B** and **D** registers 0 mA in this series-parallel circuit:

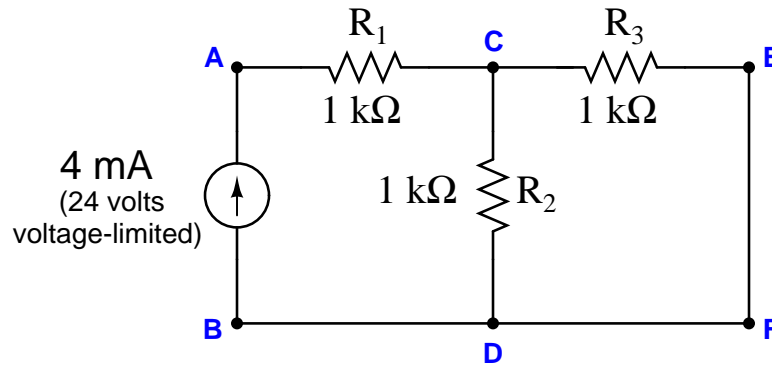

Identify the likelihood of each specified fault for this circuit. Consider each fault one at a time (i.e. no coincidental faults), determining whether or not each fault could independently account for *all* measurements and symptoms in this circuit.

Fault	Possible	Impossible
$R_1$ failed open		
$R_2$ failed open		
$R_3$ failed open		
$R_1$ failed shorted		
$R_2$ failed shorted		
$R_3$ failed shorted		
Current source dead		

Finally, identify the *next* diagnostic test or measurement you would make on this system. Explain how the result(s) of this next test or measurement help further identify the location and/or nature of the fault.

Question 19

Suppose an ammeter inserted between test points **E** and **F** registers 4 mA in this series-parallel circuit:

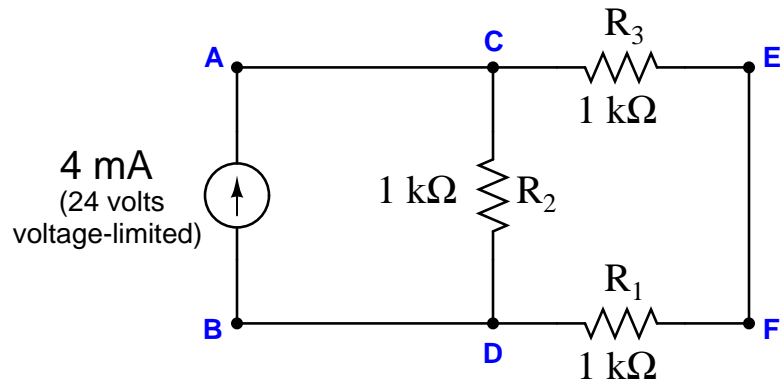

Identify the likelihood of each specified fault for this circuit. Consider each fault one at a time (i.e. no coincidental faults), determining whether or not each fault could independently account for *all* measurements and symptoms in this circuit.

Fault	Possible	Impossible
$R_1$ failed open		
$R_2$ failed open		
$R_3$ failed open		
$R_1$ failed shorted		
$R_2$ failed shorted		
$R_3$ failed shorted		
Current source dead		

Finally, explain why no further diagnostic tests or measurements are necessary to identify the location and nature of the fault.

Question 20

Suppose an ammeter inserted between test points **D** and **B** registers 16 mA in this series-parallel circuit:

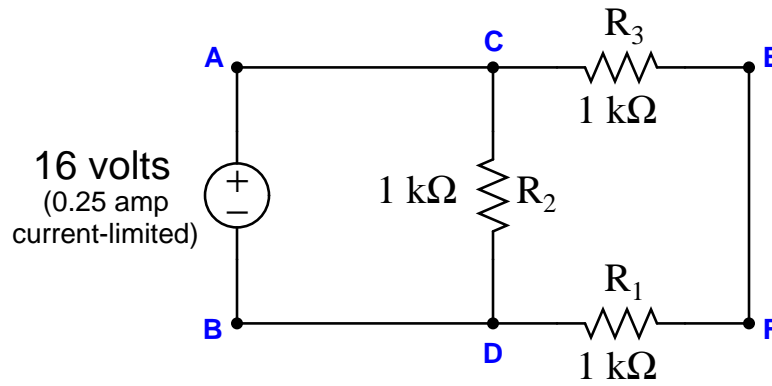

Identify the likelihood of each specified fault for this circuit. Consider each fault one at a time (i.e. no coincidental faults), determining whether or not each fault could independently account for *all* measurements and symptoms in this circuit.

Fault	Possible	Impossible
$R_1$ failed open		
$R_2$ failed open		
$R_3$ failed open		
$R_1$ failed shorted		
$R_2$ failed shorted		
$R_3$ failed shorted		
Voltage source dead		

Finally, identify the *next* diagnostic test or measurement you would make on this system. Explain how the result(s) of this next test or measurement help further identify the location and/or nature of the fault.

Question 21

Suppose a voltmeter registers 16 volts between test points **F** and **D** in this series-parallel circuit:

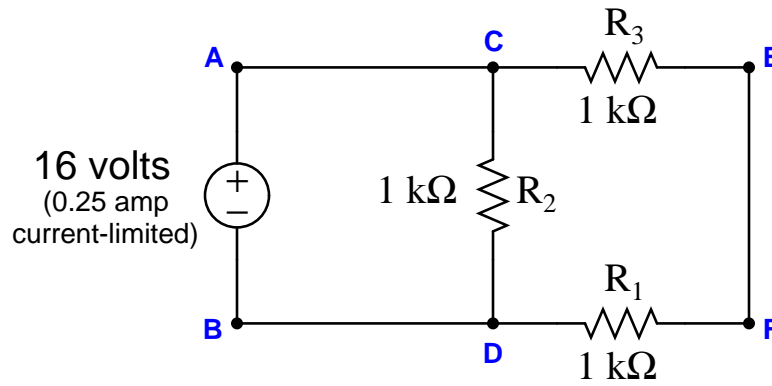

Identify the likelihood of each specified fault for this circuit. Consider each fault one at a time (i.e. no coincidental faults), determining whether or not each fault could independently account for *all* measurements and symptoms in this circuit.

Fault	Possible	Impossible
$R_1$ failed open		
$R_2$ failed open		
$R_3$ failed open		
$R_1$ failed shorted		
$R_2$ failed shorted		
$R_3$ failed shorted		
Voltage source dead		

Finally, identify the *next* diagnostic test or measurement you would make on this system. Explain how the result(s) of this next test or measurement help further identify the location and/or nature of the fault.

Question 22

Suppose an ammeter inserted between test point C and the nearest lead of resistor  $R_2$  registers 9 mA in this series-parallel circuit:

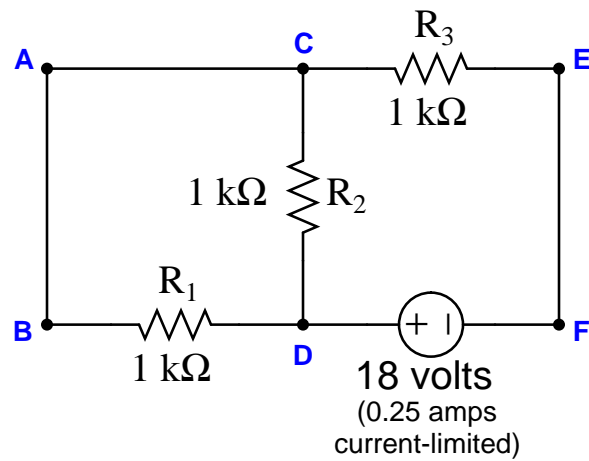

Identify the likelihood of each specified fault for this circuit. Consider each fault one at a time (i.e. no coincidental faults), determining whether or not each fault could independently account for *all* measurements and symptoms in this circuit.

Fault	Possible	Impossible
$R_1$ failed open		
$R_2$ failed open		
$R_3$ failed open		
$R_1$ failed shorted		
$R_2$ failed shorted		
$R_3$ failed shorted		
Voltage source dead		

Finally, explain why no further diagnostic tests or measurements are necessary to identify the location and nature of the fault.

Question 23

Suppose an ammeter inserted between test point **D** and the nearest lead of voltage source registers 9 mA in this series-parallel circuit:

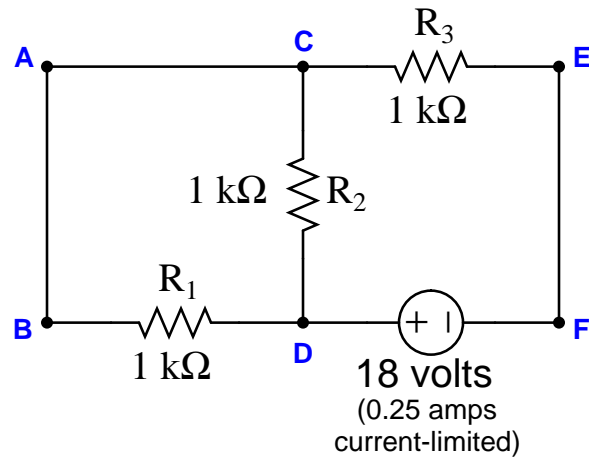

Identify the likelihood of each specified fault for this circuit. Consider each fault one at a time (i.e. no coincidental faults), determining whether or not each fault could independently account for *all* measurements and symptoms in this circuit.

Fault	Possible	Impossible
$R_1$ failed open		
$R_2$ failed open		
$R_3$ failed open		
$R_1$ failed shorted		
$R_2$ failed shorted		
$R_3$ failed shorted		
Voltage source dead		

Finally, identify the *next* diagnostic test or measurement you would make on this system. Explain how the result(s) of this next test or measurement help further identify the location and/or nature of the fault.

Question 24

Suppose a voltmeter registers 18 volts between test points **C** and **E** in this series-parallel circuit:

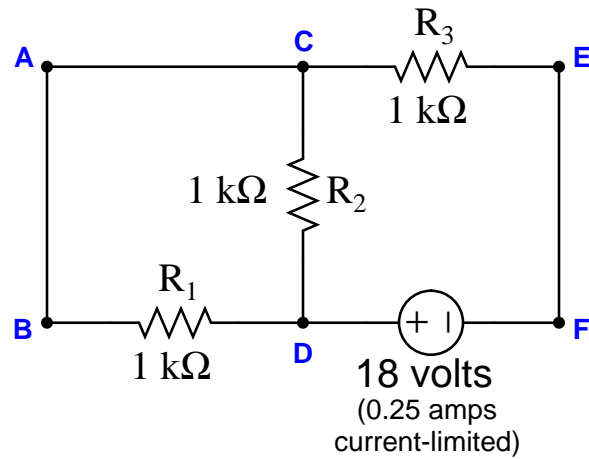

Identify the likelihood of each specified fault for this circuit. Consider each fault one at a time (i.e. no coincidental faults), determining whether or not each fault could independently account for *all* measurements and symptoms in this circuit.

Fault	Possible	Impossible
$R_1$ failed open		
$R_2$ failed open		
$R_3$ failed open		
$R_1$ failed shorted		
$R_2$ failed shorted		
$R_3$ failed shorted		
Voltage source dead		

Finally, identify the *next* diagnostic test or measurement you would make on this system. Explain how the result(s) of this next test or measurement help further identify the location and/or nature of the fault.



Question 25

Suppose a voltmeter registers 0 volts between test points **D** and **B** in this series-parallel circuit:

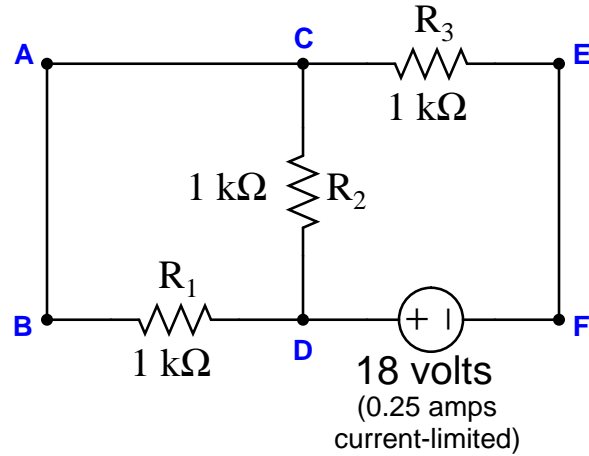

Identify the likelihood of each specified fault for this circuit. Consider each fault one at a time (i.e. no coincidental faults), determining whether or not each fault could independently account for *all* measurements and symptoms in this circuit.

Fault	Possible	Impossible
$R_1$ failed open		
$R_2$ failed open		
$R_3$ failed open		
$R_1$ failed shorted		
$R_2$ failed shorted		
$R_3$ failed shorted		
Voltage source dead		

Finally, identify the *next* diagnostic test or measurement you would make on this system. Explain how the result(s) of this next test or measurement help further identify the location and/or nature of the fault.

Question 26

Suppose a voltmeter registers 24 volts between test points **C** and **A** in this series-parallel circuit:

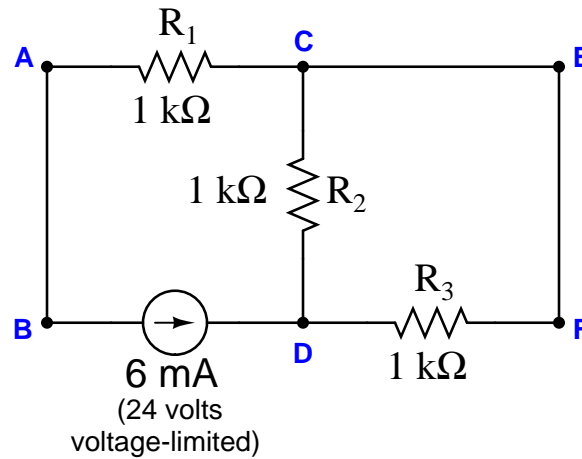

Identify the likelihood of each specified fault for this circuit. Consider each fault one at a time (i.e. no coincidental faults), determining whether or not each fault could independently account for *all* measurements and symptoms in this circuit.

Fault	Possible	Impossible
$R_1$ failed open		
$R_2$ failed open		
$R_3$ failed open		
$R_1$ failed shorted		
$R_2$ failed shorted		
$R_3$ failed shorted		
Current source dead		

Finally, explain why no further diagnostic tests or measurements are necessary to identify the location and nature of the fault.

Question 27

Suppose a voltmeter registers 4 volts between test points A and C in this series-parallel circuit:

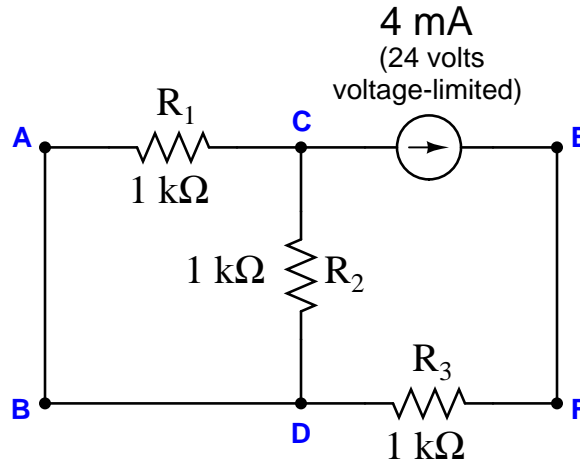

Identify the likelihood of each specified fault for this circuit. Consider each fault one at a time (i.e. no coincidental faults), determining whether or not each fault could independently account for *all* measurements and symptoms in this circuit.

Fault	Possible	Impossible
$R_1$ failed open		
$R_2$ failed open		
$R_3$ failed open		
$R_1$ failed shorted		
$R_2$ failed shorted		
$R_3$ failed shorted		
Current source dead		

Finally, explain why no further diagnostic tests or measurements are necessary to identify the location and nature of the fault.

Question 28

Suppose a voltmeter registers 0 volts between test points **C** and **E** in this series-parallel circuit:

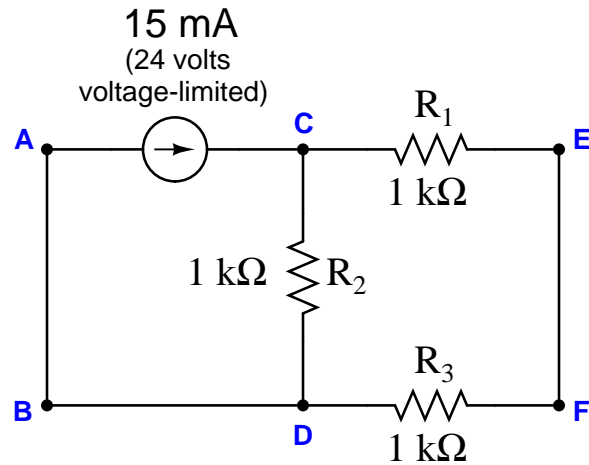

Identify the likelihood of each specified fault for this circuit. Consider each fault one at a time (i.e. no coincidental faults), determining whether or not each fault could independently account for *all* measurements and symptoms in this circuit.

Fault	Possible	Impossible
$R_1$ failed open		
$R_2$ failed open		
$R_3$ failed open		
$R_1$ failed shorted		
$R_2$ failed shorted		
$R_3$ failed shorted		
Current source dead		

Question 29

Suppose a voltmeter registers 4 volts between test points **E** and **C** in this series-parallel circuit:

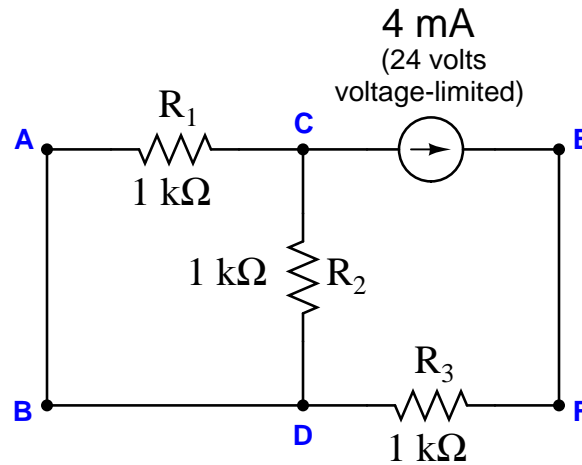

Identify the likelihood of each specified fault for this circuit. Consider each fault one at a time (i.e. no coincidental faults), determining whether or not each fault could independently account for *all* measurements and symptoms in this circuit.

Fault	Possible	Impossible
$R_1$ failed open		
$R_2$ failed open		
$R_3$ failed open		
$R_1$ failed shorted		
$R_2$ failed shorted		
$R_3$ failed shorted		
Current source dead		

Finally, identify the *next* diagnostic test or measurement you would make on this system. Explain how the result(s) of this next test or measurement help further identify the location and/or nature of the fault.

Question 30

Suppose an ammeter inserted between test point **F** and the nearest lead of resistor  $R_3$  registers 0 mA in this series-parallel circuit:

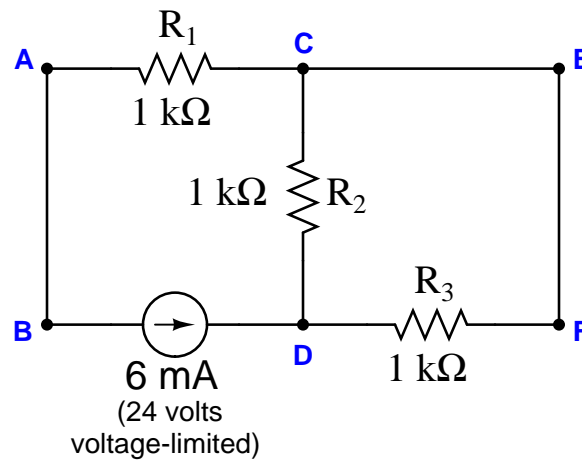

Identify the likelihood of each specified fault for this circuit. Consider each fault one at a time (i.e. no coincidental faults), determining whether or not each fault could independently account for *all* measurements and symptoms in this circuit.

Fault	Possible	Impossible
$R_1$ failed open		
$R_2$ failed open		
$R_3$ failed open		
$R_1$ failed shorted		
$R_2$ failed shorted		
$R_3$ failed shorted		
Current source dead		

Finally, identify the *next* diagnostic test or measurement you would make on this system. Explain how the result(s) of this next test or measurement help further identify the location and/or nature of the fault.

Question 31

Suppose a voltmeter registers 0 volts between test points **A** and **D** in this series-parallel circuit:

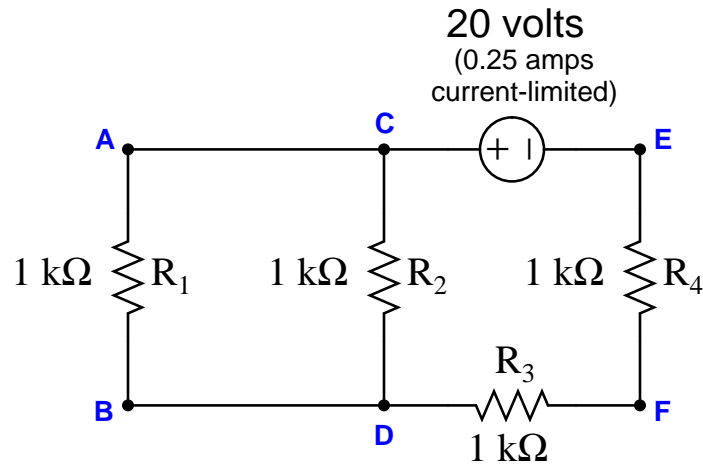

Identify the likelihood of each specified fault for this circuit. Consider each fault one at a time (i.e. no coincidental faults), determining whether or not each fault could independently account for *all* measurements and symptoms in this circuit.

Fault	Possible	Impossible
$R_1$ failed open		
$R_2$ failed open		
$R_3$ failed open		
$R_4$ failed open		
$R_1$ failed shorted		
$R_2$ failed shorted		
$R_3$ failed shorted		
$R_4$ failed shorted		
Voltage source dead		

Finally, identify the *next* diagnostic test or measurement you would make on this system. Explain how the result(s) of this next test or measurement help further identify the location and/or nature of the fault.

Question 32

Suppose a voltmeter registers 20 volts between test points **D** and **E** in this series-parallel circuit:

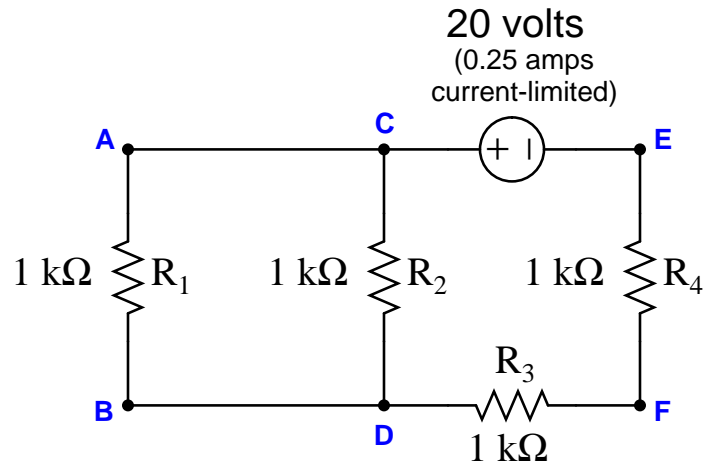

Identify the likelihood of each specified fault for this circuit. Consider each fault one at a time (i.e. no coincidental faults), determining whether or not each fault could independently account for *all* measurements and symptoms in this circuit.

Fault	Possible	Impossible
$R_1$ failed open		
$R_2$ failed open		
$R_3$ failed open		
$R_4$ failed open		
$R_1$ failed shorted		
$R_2$ failed shorted		
$R_3$ failed shorted		
$R_4$ failed shorted		
Voltage source dead		

Finally, identify the *next* diagnostic test or measurement you would make on this system. Explain how the result(s) of this next test or measurement help further identify the location and/or nature of the fault.



Question 33

Suppose a voltmeter registers 0 volts between test points **F** and **E** in this series-parallel circuit:

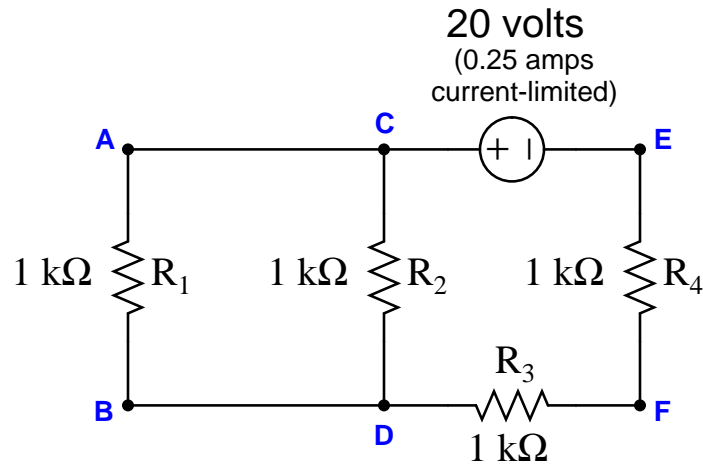

Identify the likelihood of each specified fault for this circuit. Consider each fault one at a time (i.e. no coincidental faults), determining whether or not each fault could independently account for *all* measurements and symptoms in this circuit.

Fault	Possible	Impossible
$R_1$ failed open		
$R_2$ failed open		
$R_3$ failed open		
$R_4$ failed open		
$R_1$ failed shorted		
$R_2$ failed shorted		
$R_3$ failed shorted		
$R_4$ failed shorted		
Voltage source dead		

Finally, identify the *next* diagnostic test or measurement you would make on this system. Explain how the result(s) of this next test or measurement help further identify the location and/or nature of the fault.

Question 34

Suppose a voltmeter registers 6 volts between test points **D** and **E** in this series-parallel circuit:

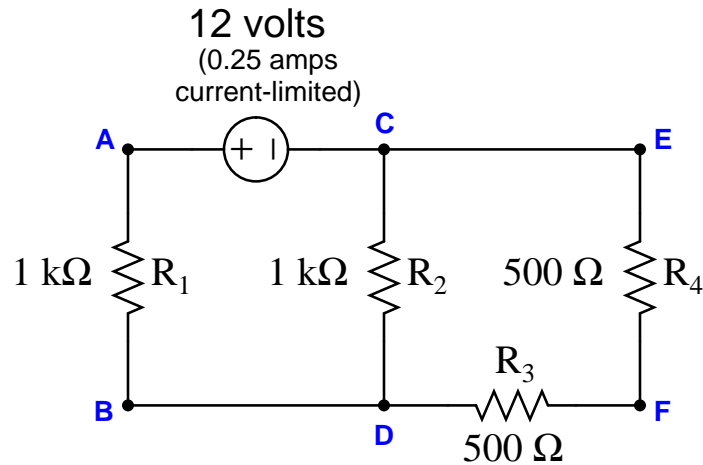

Identify the likelihood of each specified fault for this circuit. Consider each fault one at a time (i.e. no coincidental faults), determining whether or not each fault could independently account for *all* measurements and symptoms in this circuit.

Fault	Possible	Impossible
$R_1$ failed open		
$R_2$ failed open		
$R_3$ failed open		
$R_4$ failed open		
$R_1$ failed shorted		
$R_2$ failed shorted		
$R_3$ failed shorted		
$R_4$ failed shorted		
Voltage source dead		

Finally, identify the *next* diagnostic test or measurement you would make on this system. Explain how the result(s) of this next test or measurement help further identify the location and/or nature of the fault.

Question 35

Suppose a voltmeter registers 12 volts between test points **A** and **D** in this series-parallel circuit:

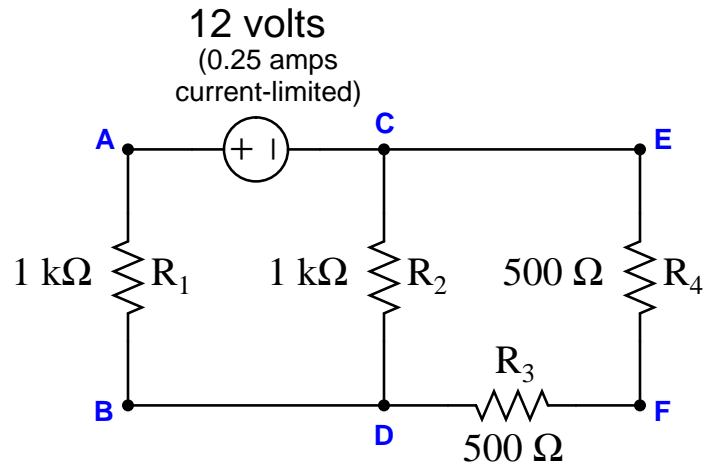

Identify the likelihood of each specified fault for this circuit. Consider each fault one at a time (i.e. no coincidental faults), determining whether or not each fault could independently account for *all* measurements and symptoms in this circuit.

Fault	Possible	Impossible
R <sub>1</sub> failed open		
R <sub>2</sub> failed open		
R <sub>3</sub> failed open		
R <sub>4</sub> failed open		
R <sub>1</sub> failed shorted		
R <sub>2</sub> failed shorted		
R <sub>3</sub> failed shorted		
R <sub>4</sub> failed shorted		
Voltage source dead		

Finally, identify the *next* diagnostic test or measurement you would make on this system. Explain how the result(s) of this next test or measurement help further identify the location and/or nature of the fault.

Question 36

Suppose a voltmeter registers 13.33 volts between test points **D** and **E** in this series-parallel circuit:

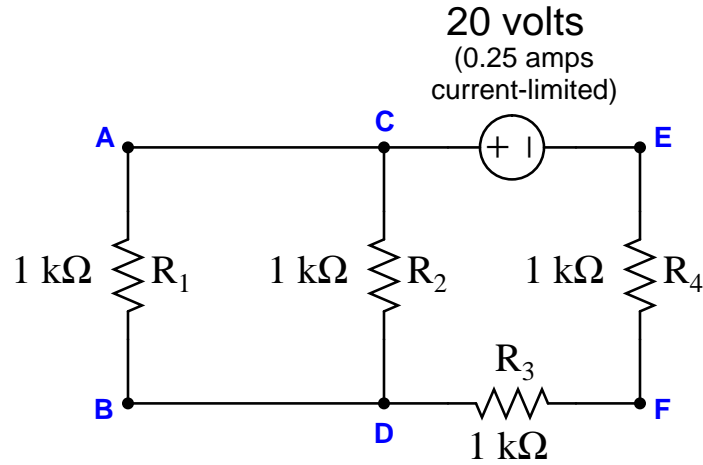

Identify the likelihood of each specified fault for this circuit. Consider each fault one at a time (i.e. no coincidental faults), determining whether or not each fault could independently account for *all* measurements and symptoms in this circuit.

Fault	Possible	Impossible
$R_1$ failed open		
$R_2$ failed open		
$R_3$ failed open		
$R_4$ failed open		
$R_1$ failed shorted		
$R_2$ failed shorted		
$R_3$ failed shorted		
$R_4$ failed shorted		
Voltage source dead		

Finally, identify the *next* diagnostic test or measurement you would make on this system. Explain how the result(s) of this next test or measurement help further identify the location and/or nature of the fault.

Question 37

Suppose a voltmeter registers 12 volts between test points **D** and **A** in this series-parallel circuit:

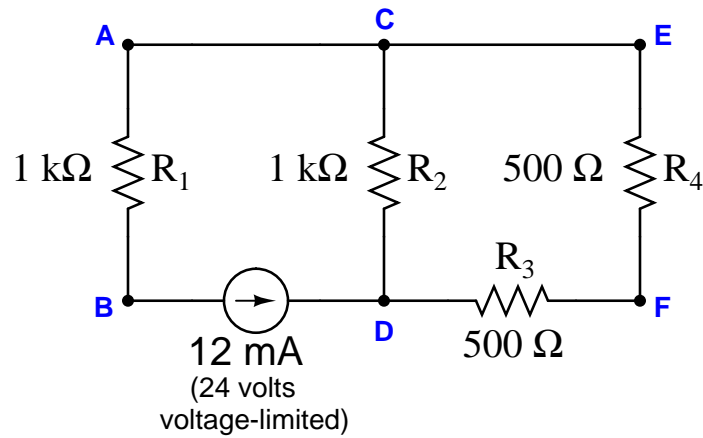

Identify the likelihood of each specified fault for this circuit. Consider each fault one at a time (i.e. no coincidental faults), determining whether or not each fault could independently account for *all* measurements and symptoms in this circuit.

Fault	Possible	Impossible
$R_1$ failed open		
$R_2$ failed open		
$R_3$ failed open		
$R_4$ failed open		
$R_1$ failed shorted		
$R_2$ failed shorted		
$R_3$ failed shorted		
$R_4$ failed shorted		
Current source dead		

Finally, identify the *next* diagnostic test or measurement you would make on this system. Explain how the result(s) of this next test or measurement help further identify the location and/or nature of the fault.

Question 38

Suppose a voltmeter registers 24 volts between test points **A** and **B** in this series-parallel circuit:

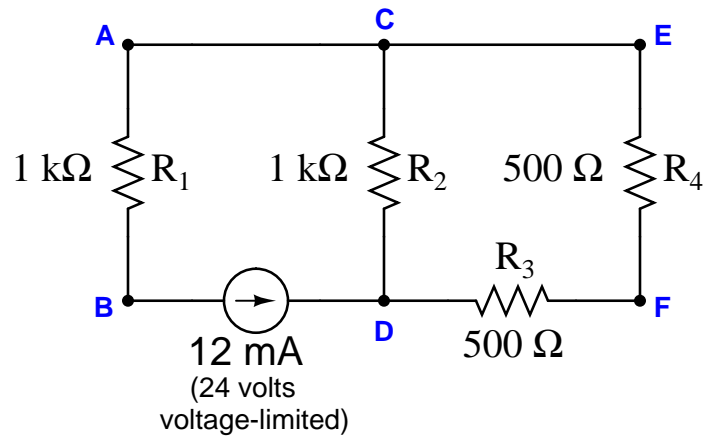

Identify the likelihood of each specified fault for this circuit. Consider each fault one at a time (i.e. no coincidental faults), determining whether or not each fault could independently account for *all* measurements and symptoms in this circuit.

Fault	Possible	Impossible
$R_1$ failed open		
$R_2$ failed open		
$R_3$ failed open		
$R_4$ failed open		
$R_1$ failed shorted		
$R_2$ failed shorted		
$R_3$ failed shorted		
$R_4$ failed shorted		
Current source dead		

Finally, explain why no further diagnostic tests or measurements are necessary to identify the location and nature of the fault.

Question 39

Suppose an ammeter inserted between test point **F** and the nearest lead of resistor  $R_4$  registers 0 mA in this series-parallel circuit:

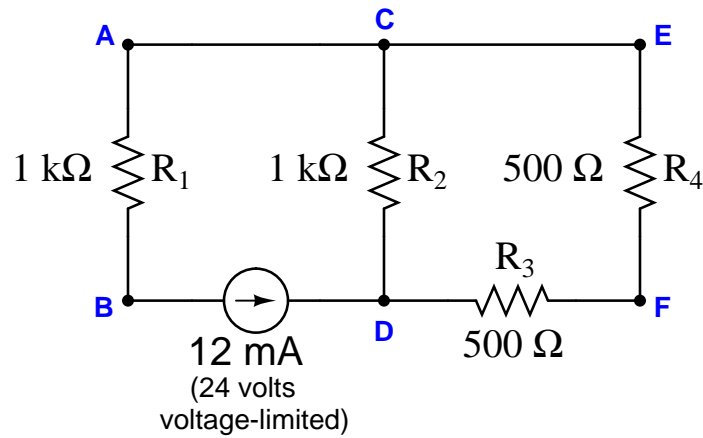

Identify the likelihood of each specified fault for this circuit. Consider each fault one at a time (i.e. no coincidental faults), determining whether or not each fault could independently account for *all* measurements and symptoms in this circuit.

Fault	Possible	Impossible
$R_1$ failed open		
$R_2$ failed open		
$R_3$ failed open		
$R_4$ failed open		
$R_1$ failed shorted		
$R_2$ failed shorted		
$R_3$ failed shorted		
$R_4$ failed shorted		
Current source dead		

Finally, identify the *next* diagnostic test or measurement you would make on this system. Explain how the result(s) of this next test or measurement help further identify the location and/or nature of the fault.

Question 40

Suppose an ammeter inserted between test point C and the nearest lead of resistor  $R_2$  registers 0 mA in this series-parallel circuit:

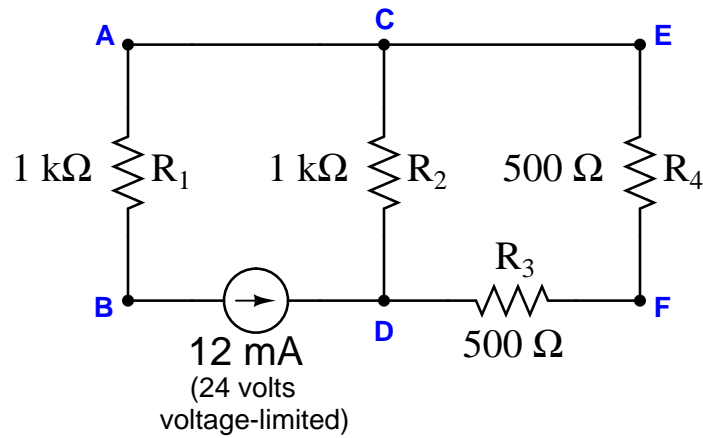

Identify the likelihood of each specified fault for this circuit. Consider each fault one at a time (i.e. no coincidental faults), determining whether or not each fault could independently account for *all* measurements and symptoms in this circuit.

Fault	Possible	Impossible
$R_1$ failed open		
$R_2$ failed open		
$R_3$ failed open		
$R_4$ failed open		
$R_1$ failed shorted		
$R_2$ failed shorted		
$R_3$ failed shorted		
$R_4$ failed shorted		
Current source dead		

Finally, identify the *next* diagnostic test or measurement you would make on this system. Explain how the result(s) of this next test or measurement help further identify the location and/or nature of the fault.



Question 41

Suppose a voltmeter registers 0 volts between test points **A** and **C**, and also measures 0 volts between those same two test points after the connection has been broken between points **A** and **B**:

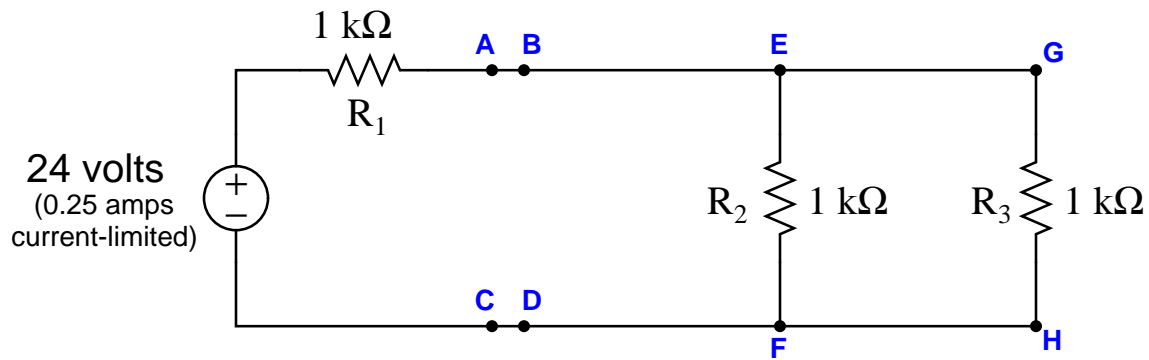

Identify the likelihood of each specified fault for this circuit. Consider each fault one at a time (i.e. no coincidental faults), determining whether or not each fault could independently account for *all* measurements and symptoms in this circuit.

Fault	Possible	Impossible
$R_1$ failed open		
$R_2$ failed open		
$R_3$ failed open		
$R_1$ failed shorted		
$R_2$ failed shorted		
$R_3$ failed shorted		
Voltage source dead		

Finally, identify the *next* diagnostic test or measurement you would make on this system. Explain how the result(s) of this next test or measurement help further identify the location and/or nature of the fault.

Question 42

Suppose a voltmeter registers 9 volts between test points **B** and **C**, but measures 18 volts between those same two test points after the connection has been broken between points **E** and **G**:

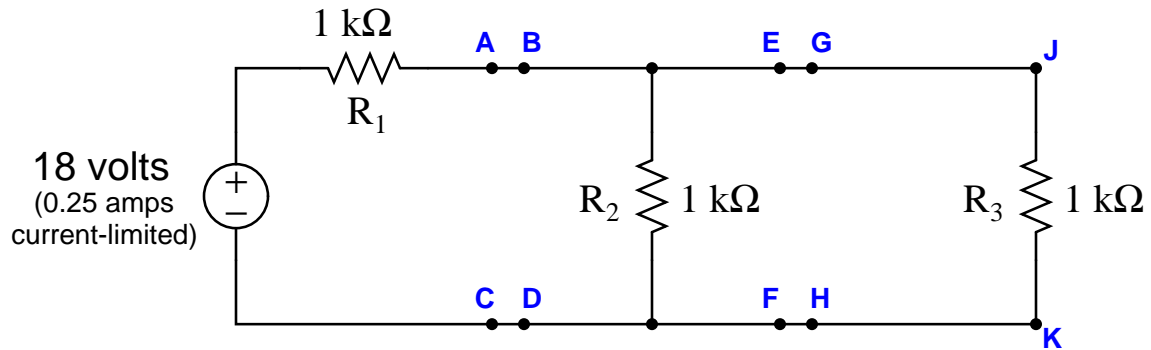

Identify the likelihood of each specified fault for this circuit. Consider each fault one at a time (i.e. no coincidental faults), determining whether or not each fault could independently account for *all* measurements and symptoms in this circuit.

Fault	Possible	Impossible
$R_1$ failed open		
$R_2$ failed open		
$R_3$ failed open		
$R_1$ failed shorted		
$R_2$ failed shorted		
$R_3$ failed shorted		
Voltage source dead		

Finally, explain why no further diagnostic tests or measurements are necessary to identify the location and nature of the fault.

Question 43

Suppose a voltmeter registers 0 volts between test points **B** and **C**, and measures 24 volts between those same two test points after the connection has been broken between points **A** and **B**:

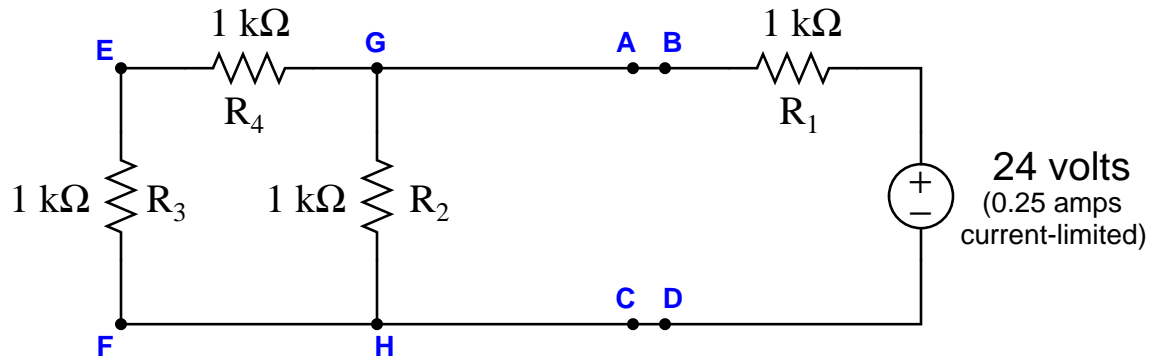

Identify the likelihood of each specified fault for this circuit. Consider each fault one at a time (i.e. no coincidental faults), determining whether or not each fault could independently account for *all* measurements and symptoms in this circuit.

Fault	Possible	Impossible
$R_1$ failed open		
$R_2$ failed open		
$R_3$ failed open		
$R_4$ failed open		
$R_1$ failed shorted		
$R_2$ failed shorted		
$R_3$ failed shorted		
$R_4$ failed shorted		
Voltage source dead		

Question 44

Suppose a voltmeter registers 0 volts between test points **E** and **F**, and 9 volts between test points **F** and **H** when the connection between **F** and **H** has been broken:

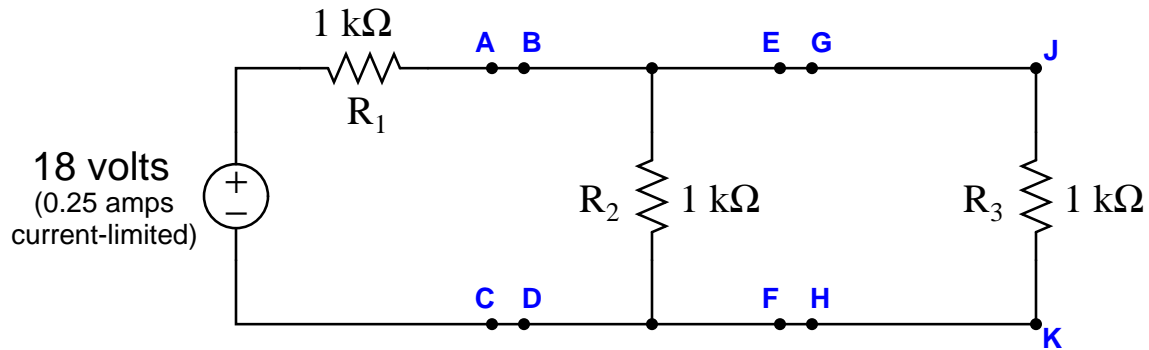

Identify the likelihood of each specified fault for this circuit. Consider each fault one at a time (i.e. no coincidental faults), determining whether or not each fault could independently account for *all* measurements and symptoms in this circuit.

Fault	Possible	Impossible
$R_1$ failed open		
$R_2$ failed open		
$R_3$ failed open		
$R_1$ failed shorted		
$R_2$ failed shorted		
$R_3$ failed shorted		
Voltage source dead		

Finally, explain why no further diagnostic tests or measurements are necessary to identify the location and nature of the fault.

Question 45

Suppose a voltmeter registers 24 volts between test points **E** and **C** while the pushbutton is released (not pressed), and 0 volts between test points **A** and **B** while the pushbutton is pressed:

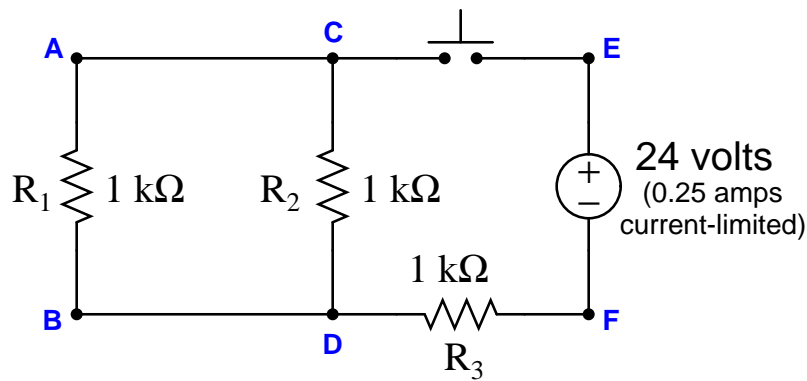

Identify the likelihood of each specified fault for this circuit. Consider each fault one at a time (i.e. no coincidental faults), determining whether or not each fault could independently account for *all* measurements and symptoms in this circuit.

Fault	Possible	Impossible
Switch failed open		
$R_1$ failed open		
$R_2$ failed open		
$R_3$ failed open		
Switch failed shorted		
$R_1$ failed shorted		
$R_2$ failed shorted		
$R_3$ failed shorted		
Voltage source dead		

Finally, identify the *next* diagnostic test or measurement you would make on this system. Explain how the result(s) of this next test or measurement help further identify the location and/or nature of the fault.

Question 46

Suppose a voltmeter registers 6 volts between test points **C** and **D** while the pushbutton is released (not pressed), and also 6 volts between the same test points while the pushbutton is pressed:

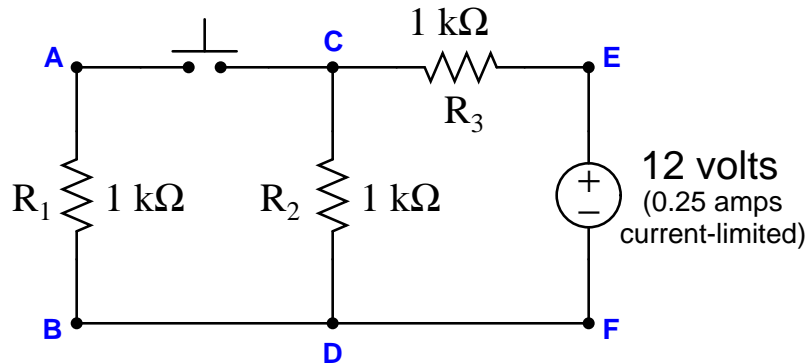

Identify the likelihood of each specified fault for this circuit. Consider each fault one at a time (i.e. no coincidental faults), determining whether or not each fault could independently account for *all* measurements and symptoms in this circuit.

Fault	Possible	Impossible
Switch failed open		
$R_1$ failed open		
$R_2$ failed open		
$R_3$ failed open		
Switch failed shorted		
$R_1$ failed shorted		
$R_2$ failed shorted		
$R_3$ failed shorted		
Voltage source dead		

Finally, identify the *next* diagnostic test or measurement you would make on this system. Explain how the result(s) of this next test or measurement help further identify the location and/or nature of the fault.

Question 47

Suppose a voltmeter registers 0 volts between test points **C** and **F**, but measures 24 volts between those same test points when the connection between **B** and **C** is broken:

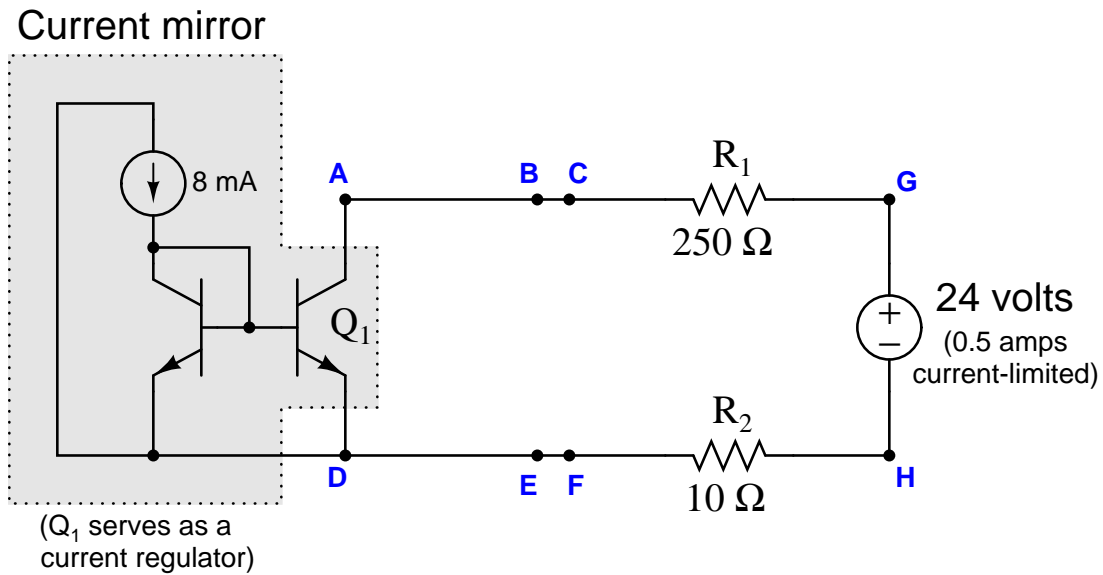

Identify the likelihood of each specified fault for this circuit. Consider each fault one at a time (i.e. no coincidental faults), determining whether or not each fault could independently account for *all* measurements and symptoms in this circuit.

Fault	Possible	Impossible
$R_1$ failed open		
$R_2$ failed open		
$Q_1$ failed open		
$R_1$ failed shorted		
$R_2$ failed shorted		
$Q_1$ failed shorted		
Voltage source dead		

Finally, explain why no further diagnostic tests or measurements are necessary to identify the location and nature of the fault.

Question 48

Suppose a voltmeter registers 22 volts between test points A and D:

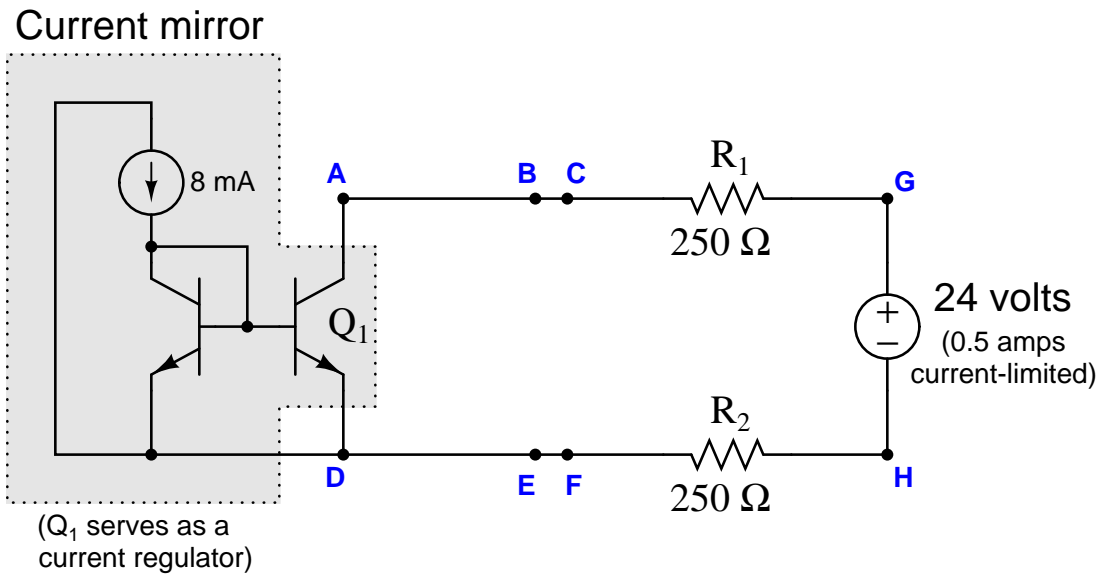

Identify the likelihood of each specified fault for this circuit. Consider each fault one at a time (i.e. no coincidental faults), determining whether or not each fault could independently account for *all* measurements and symptoms in this circuit.

Fault	Possible	Impossible
$R_1$ failed open		
$R_2$ failed open		
$Q_1$ failed open		
$R_1$ failed shorted		
$R_2$ failed shorted		
$Q_1$ failed shorted		
Voltage source dead		

Finally, identify the *next* diagnostic test or measurement you would make on this system. Explain how the result(s) of this next test or measurement help further identify the location and/or nature of the fault.



Question 49

Suppose the voltmeter in this bridge circuit registers a strong *negative* voltage:

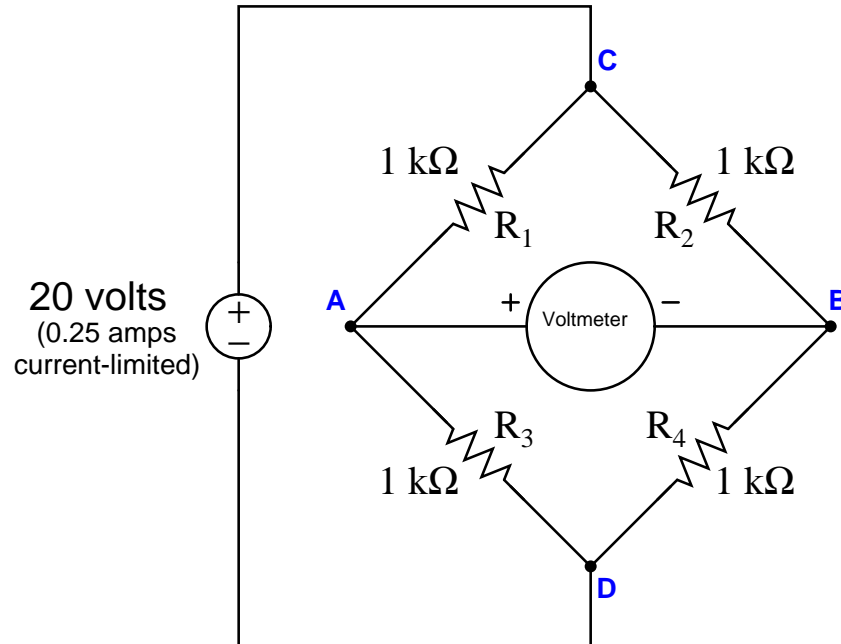

Identify the likelihood of each specified fault for this circuit. Consider each fault one at a time (i.e. no coincidental faults), determining whether or not each fault could independently account for *all* measurements and symptoms in this circuit.

Fault	Possible	Impossible
$R_1$ failed open		
$R_2$ failed open		
$R_3$ failed open		
$R_4$ failed open		
$R_1$ failed shorted		
$R_2$ failed shorted		
$R_3$ failed shorted		
$R_4$ failed shorted		
Voltage source dead		

Finally, identify the *next* diagnostic test or measurement you would make on this system. Explain how the result(s) of this next test or measurement help further identify the location and/or nature of the fault.

Question 50

Suppose the voltmeter in this bridge circuit registers a strong *positive* voltage. A test using a digital multimeter (DMM) shows the voltage between test points **A** and **B** to be 12 volts:

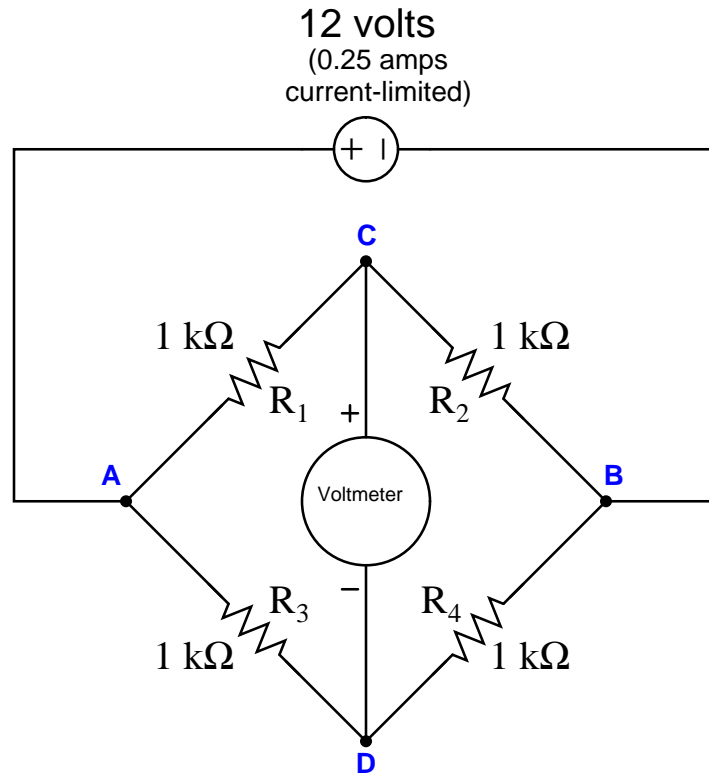

Identify the likelihood of each specified fault for this circuit. Consider each fault one at a time (i.e. no coincidental faults), determining whether or not each fault could independently account for *all* measurements and symptoms in this circuit.

Fault	Possible	Impossible
$R_1$ failed open		
$R_2$ failed open		
$R_3$ failed open		
$R_4$ failed open		
$R_1$ failed shorted		
$R_2$ failed shorted		
$R_3$ failed shorted		
$R_4$ failed shorted		
Voltage source dead		

Finally, identify the *next* diagnostic test or measurement you would make on this system. Explain how the result(s) of this next test or measurement help further identify the location and/or nature of the fault.

Question 51

Suppose the voltmeter in this bridge circuit registers a strong *negative* voltage. A test using a digital multimeter (DMM) shows the voltage between test points **A** and **C** to be 4 volts:

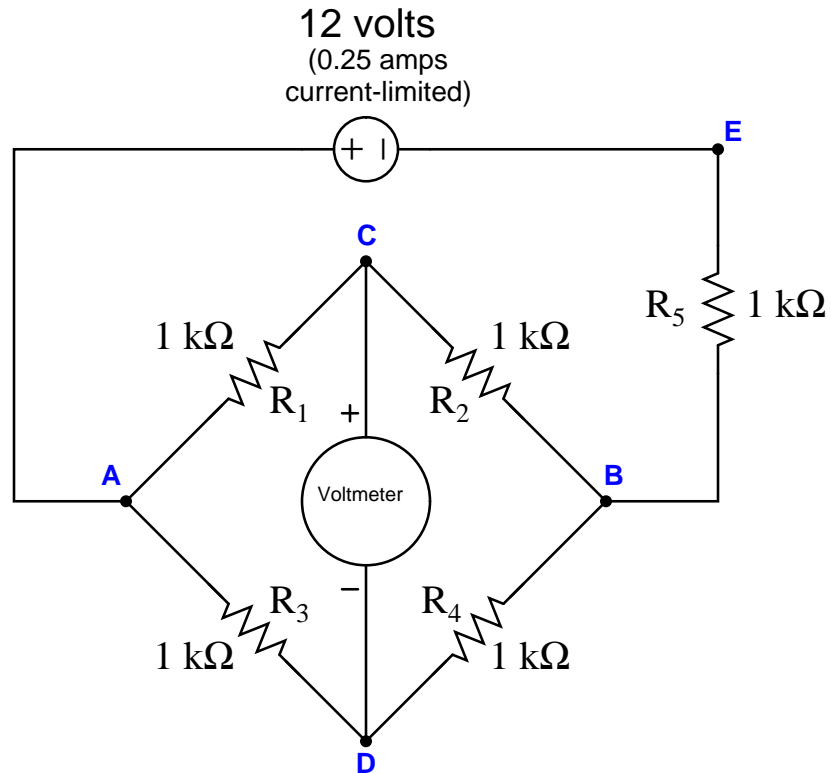

Identify the likelihood of each specified fault for this circuit. Consider each fault one at a time (i.e. no coincidental faults), determining whether or not each fault could independently account for *all* measurements and symptoms in this circuit.

Fault	Possible	Impossible
$R_1$ failed open		
$R_2$ failed open		
$R_3$ failed open		
$R_4$ failed open		
$R_5$ failed open		
$R_1$ failed shorted		
$R_2$ failed shorted		
$R_3$ failed shorted		
$R_4$ failed shorted		
$R_5$ failed shorted		
Voltage source dead		

Finally, identify the *next* diagnostic test or measurement you would make on this system. Explain how the result(s) of this next test or measurement help further identify the location and/or nature of the fault.

Question 52

Suppose the voltmeter in this circuit registers a strong *negative* voltage. A test using a digital multimeter (DMM) shows the voltage between test points **A** and **B** to be 0.8 volts:

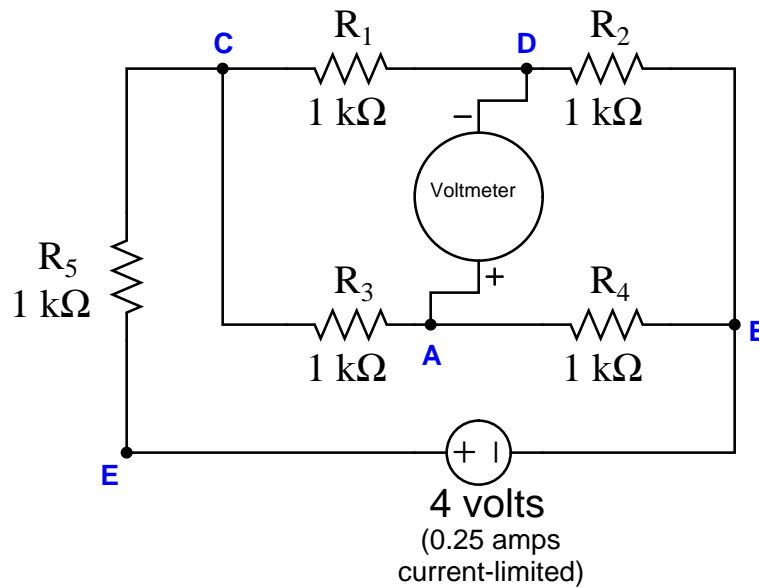

Identify the likelihood of each specified fault for this circuit. Consider each fault one at a time (i.e. no coincidental faults), determining whether or not each fault could independently account for *all* measurements and symptoms in this circuit.

Fault	Possible	Impossible
$R_1$ failed open		
$R_2$ failed open		
$R_3$ failed open		
$R_4$ failed open		
$R_5$ failed open		
$R_1$ failed shorted		
$R_2$ failed shorted		
$R_3$ failed shorted		
$R_4$ failed shorted		
$R_5$ failed shorted		
Voltage source dead		

Finally, identify the *next* diagnostic test or measurement you would make on this system. Explain how the result(s) of this next test or measurement help further identify the location and/or nature of the fault.

Question 53

An Automation Direct model C0-08TD1 “sinking” DC output PLC module uses the following internal circuitry to switch DC power to a load:

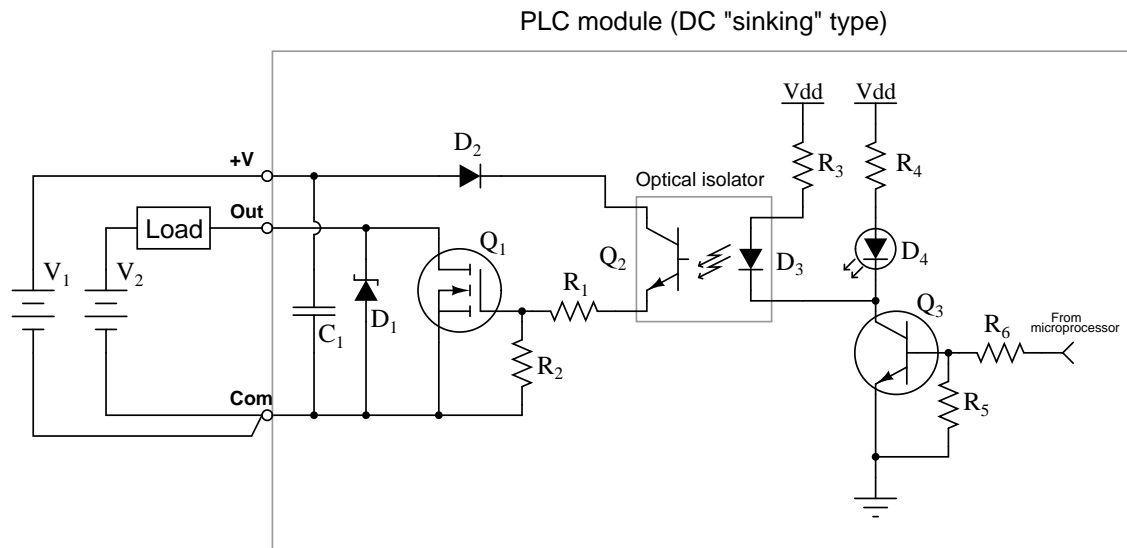

Suppose the microprocessor is sending a “high” (1) signal to the switching circuitry, but the DC load refuses to energize. Using your DC voltmeter, you measure 24.7 volts DC between the “+V” and “Com” terminals, and 23.2 volts DC between the “Out” and “Com” terminals.

Identify the likelihood of each specified fault for this circuit. Consider each fault one at a time (i.e. no coincidental faults), determining whether or not each fault could independently account for *all* measurements and symptoms in this circuit.

Fault	Possible	Impossible
Diode $D_1$ failed open		
Diode $D_2$ failed open		
Diode $D_3$ failed open		
Diode $D_4$ failed open		
Transistor $Q_1$ failed open		
Transistor $Q_2$ failed open		
Transistor $Q_3$ failed open		
Resistor $R_1$ failed open		
Resistor $R_2$ failed open		
Resistor $R_3$ failed open		
Resistor $R_4$ failed open		
Resistor $R_5$ failed open		
Resistor $R_6$ failed open		

Finally, identify the *next* diagnostic test or measurement you would make on this system. Explain how the result(s) of this next test or measurement help further identify the location and/or nature of the fault.

Question 54

An Automation Direct model C0-08TD2 “sourcing” DC output PLC module uses the following internal circuitry to switch DC power to a load:

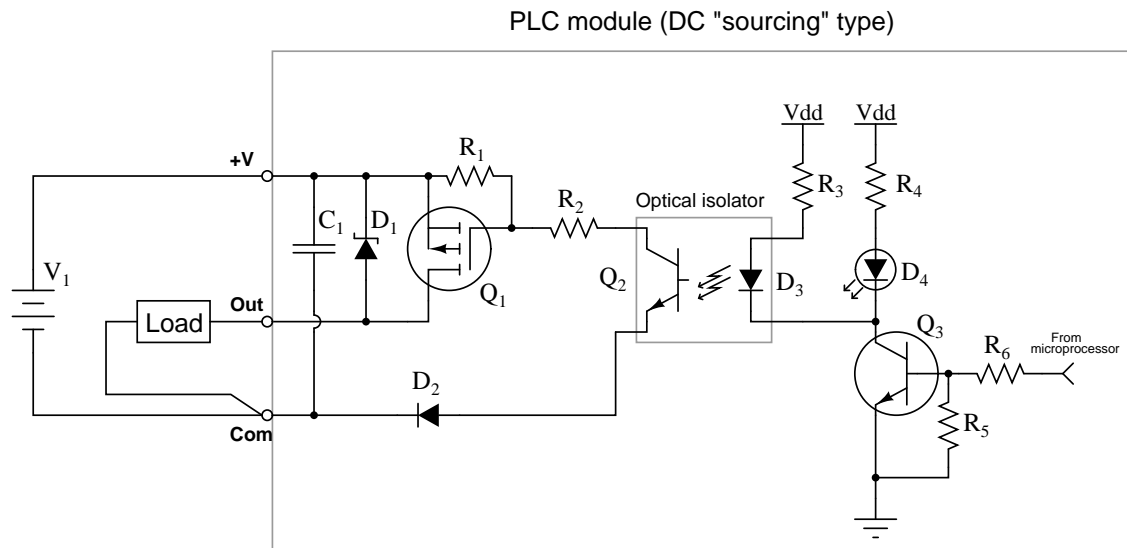

Suppose the microprocessor is sending a “high” (1) signal to the switching circuitry, but the DC load refuses to energize. Using your DC voltmeter, you measure 24.7 volts DC between the “+V” and “Com” terminals, and 0 volts DC between the “Out” and “Com” terminals.

Identify the likelihood of each specified fault for this circuit. Consider each fault one at a time (i.e. no coincidental faults), determining whether or not each fault could independently account for *all* measurements and symptoms in this circuit.

Fault	Possible	Impossible
Diode $D_1$ failed shorted		
Diode $D_2$ failed open		
Diode $D_3$ failed open		
Diode $D_4$ failed open		
Transistor $Q_1$ failed open		
Transistor $Q_2$ failed open		
Transistor $Q_3$ failed shorted		
Capacitor $C_1$ failed open		
Resistor $R_1$ failed shorted		
Resistor $R_2$ failed shorted		
Resistor $R_3$ failed open		
Resistor $R_4$ failed open		
Resistor $R_5$ failed shorted		
Resistor $R_6$ failed open		

Finally, identify the *next* diagnostic test or measurement you would make on this system. Explain how the result(s) of this next test or measurement help further identify the location and/or nature of the fault.

[file i03665](#)

Question 55

Suppose this electric-driven air compressor refuses to start when the switch is in the “Auto” position, but starts up immediately when the switch is placed in the “Hand” position. The first test performed by a technician is to measure AC voltage between test points **A** and **F** with the switch in the “Auto” position. There, the meter registers 117 volts AC. You are then called in to help:

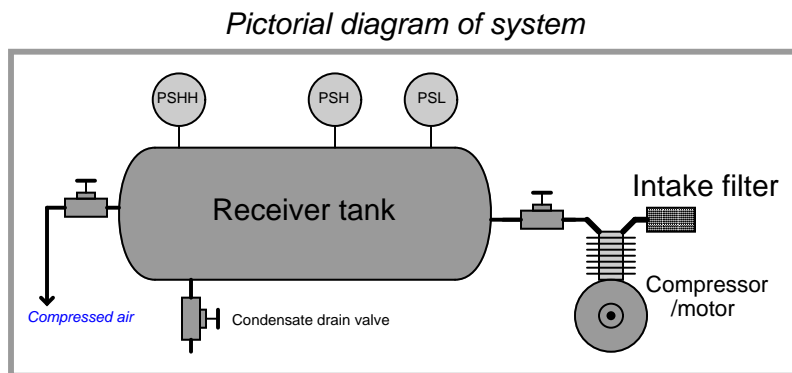
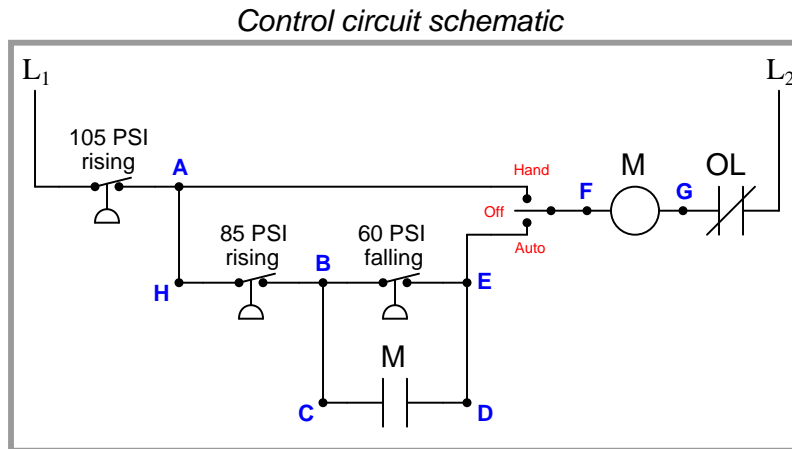

Identify the likelihood of each specified fault for this circuit. Consider each fault one at a time (i.e. no coincidental faults), determining whether or not each fault could independently account for *all* measurements and symptoms in this circuit.

Fault	Possible	Impossible
PSHH failed open		
PSH failed open		
PSL failed open		
“Hand” switch position failed open		
“Auto” switch position failed open		
OL contact failed open		
Auxiliary “M” contact failed		
Contactora “M” coil failed open		

Also, comment on whether or not the initial test between points **A** and **F** was a useful one (i.e. did it provide any new information to help diagnose the problem?).

[file i03458](#)

Question 56

Suppose this electric-driven air compressor cycles between 60 PSI and 105 PSI when the switch is in the “Auto” position, and cycles between 102 PSI and 105 PSI when in the “Hand” position:

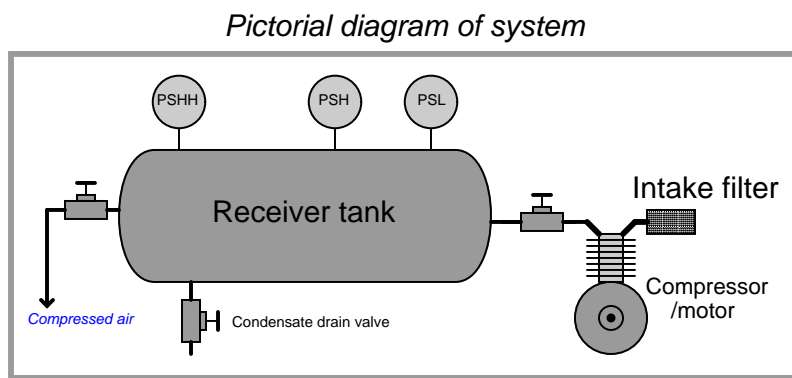
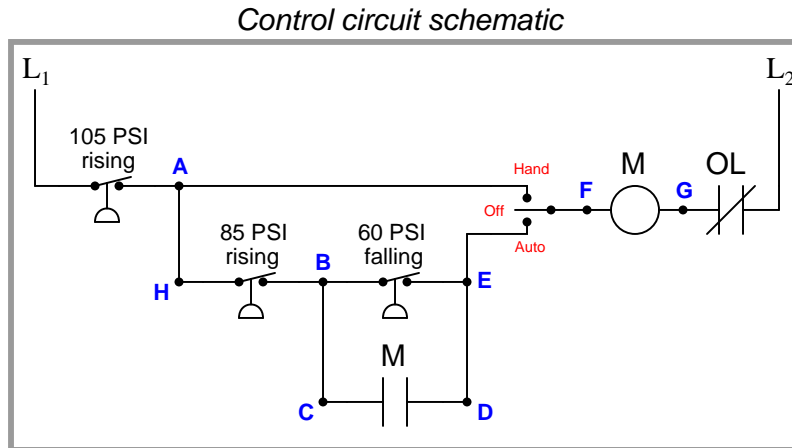

Identify the likelihood of each specified fault for this circuit. Consider each fault one at a time (i.e. no coincidental faults), determining whether or not each fault could independently account for *all* measurements and symptoms in this circuit.

Fault	Possible	Impossible
PSHH failed open		
PSH failed open		
PSL failed open		
Auxiliary “M” contact failed open		
PSHH failed shorted		
PSH failed shorted		
PSL failed shorted		
Auxiliary “M” contact failed shorted		

file i03459



### Question 57

This pictorial diagram shows the wiring connections for a simple pressure control loop, where a loop-powered 4-20 mA pressure transmitter sends a signal to a Honeywell controller, which in turn sends another 4-20 mA signal to a control valve:

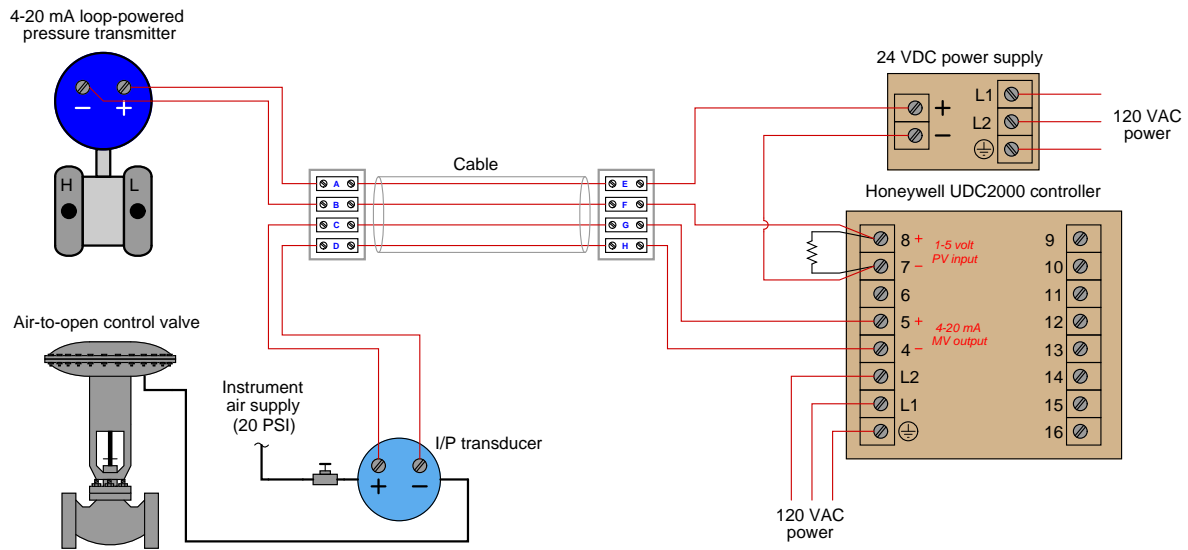

If an operator informs you that the pressure indicated by the Honeywell controller is below range (“pegged” full downscale, reading -10%), what types and locations of electrical faults might you suspect? Are there any non-electrical faults which might also cause this to happen?

[file i02696](#)

### Question 58

This pictorial diagram shows the wiring connections for a simple pressure control loop, where a loop-powered 4-20 mA pressure transmitter sends a signal to a Honeywell controller, which in turn sends another 4-20 mA signal to a control valve:

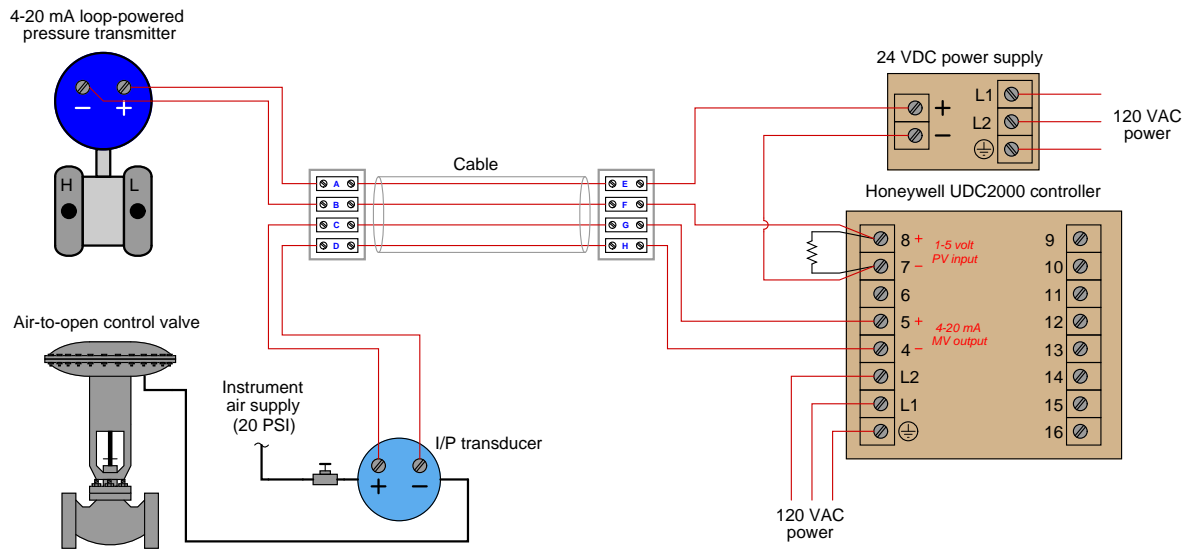

If an operator informs you that the pressure indicated by the Honeywell controller is above range (“pegged” full upscale, reading +110%), what types and locations of electrical faults might you suspect? Are there any non-electrical faults which might also cause this to happen?

[file i01117](#)

Question 59

This pictorial diagram shows the wiring connections for a simple pressure control loop, where a loop-powered 4-20 mA pressure transmitter sends a signal to a Honeywell controller, which in turn sends another 4-20 mA signal to a control valve:

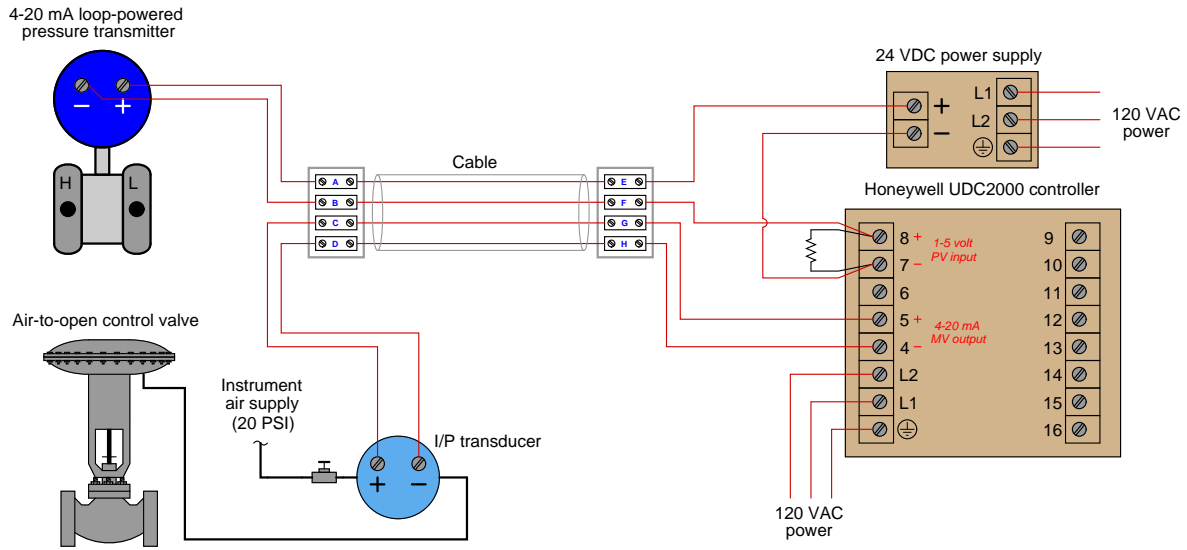

If an operator informs you that the control valve refuses to open even in manual mode, what types and locations of electrical faults might you suspect? Are there any non-electrical faults which might also cause this to happen?

[file i02697](#)

Question 60

This pressure-measurement system seems to have a problem. The pressure gauge (PG) indicates 30 PSI, but the pressure indicator (PI) reads less than 0 PSI (“pegged” fully down-scale). A voltmeter connected between terminals 7 and 8 registers 0 VDC:

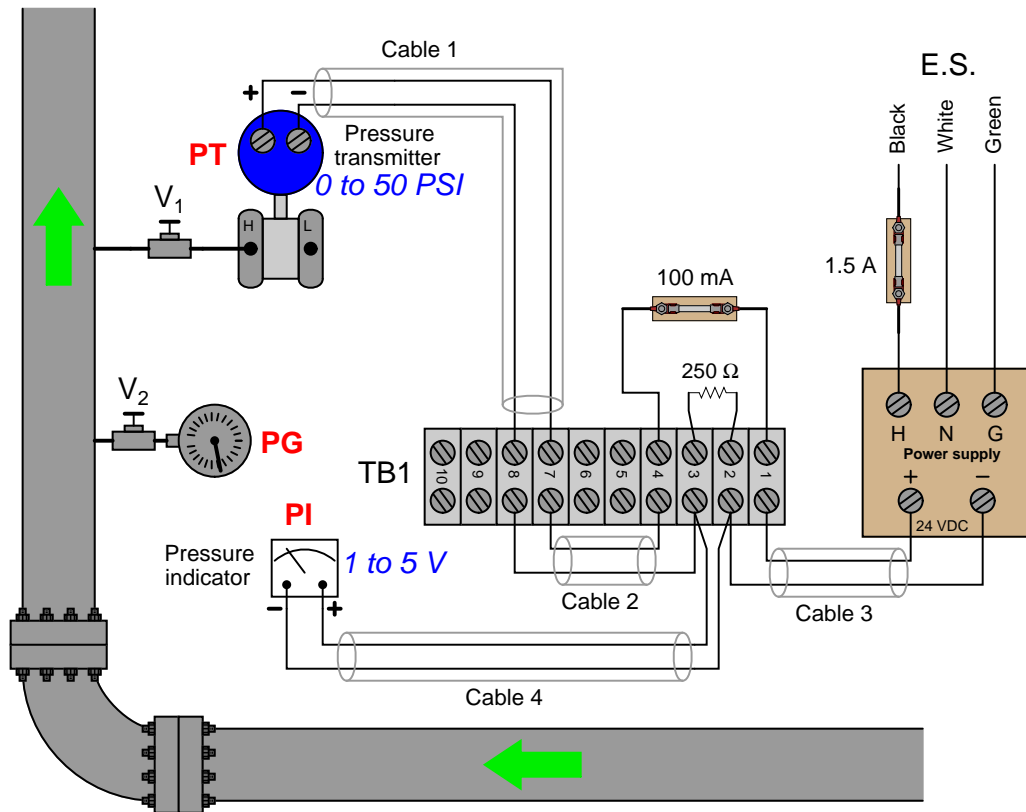

Identify the likelihood of each specified fault for this circuit. Consider each fault one at a time (i.e. no coincidental faults), determining whether or not each fault could independently account for *all* measurements and symptoms in this circuit.

Fault	Possible	Impossible
250 ohm resistor failed open		
100 mA fuse blown		
1.5 A fuse blown		
Cable 1 failed open		
Cable 4 failed open		
Cable 1 failed shorted		
Cable 4 failed shorted		

[file i03601](#)

Question 61

This pressure-measurement system seems to have a problem. The pressure gauge (PG) indicates 30 PSI, but the pressure indicator (PI) reads over 50 PSI (“pegged” fully up-scale). A voltmeter connected between terminals 4 and 2 registers 24 VDC:

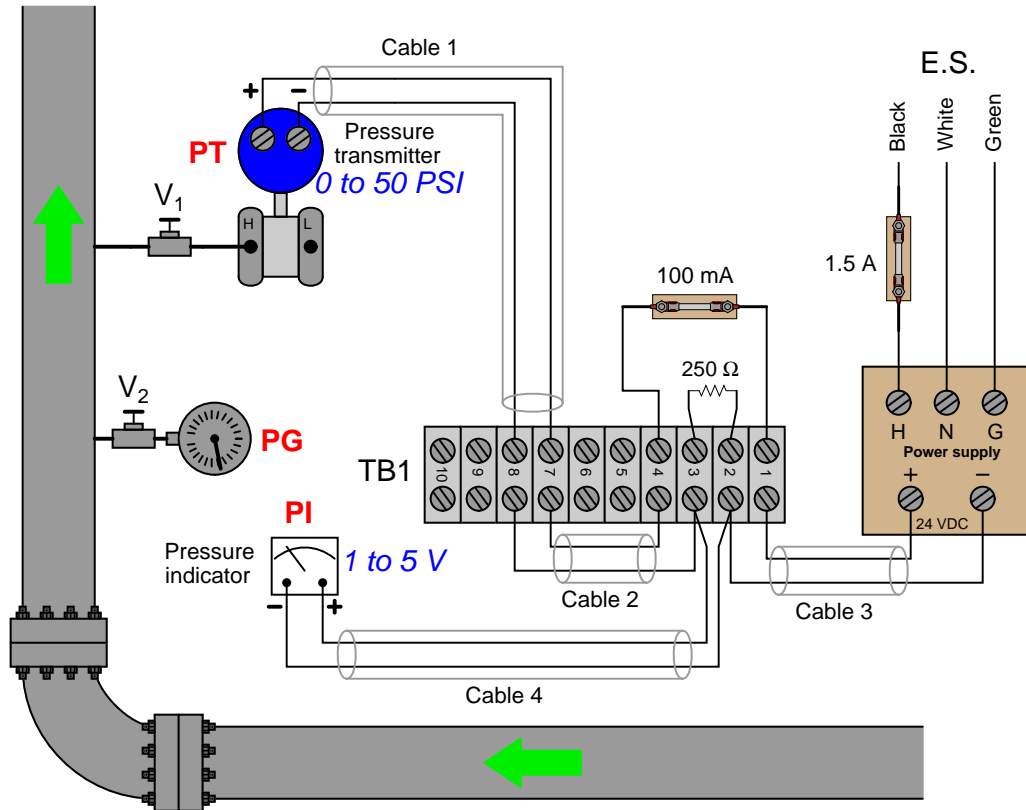

Identify the likelihood of each specified fault for this circuit. Consider each fault one at a time (i.e. no coincidental faults), determining whether or not each fault could independently account for *all* measurements and symptoms in this circuit.

Fault	Possible	Impossible
250 ohm resistor failed open		
100 mA fuse blown		
1.5 A fuse blown		
Cable 1 failed open		
Cable 4 failed open		
Cable 1 failed shorted		
Cable 4 failed shorted		

[file i03602](#)

Question 62

This pressure-measurement system seems to have a problem. The pressure gauge (PG) indicates 30 PSI, but the pressure indicator (PI) reads less than 0 PSI (“pegged” fully down-scale). A voltmeter connected between terminals 7 and 8 registers 24 VDC:

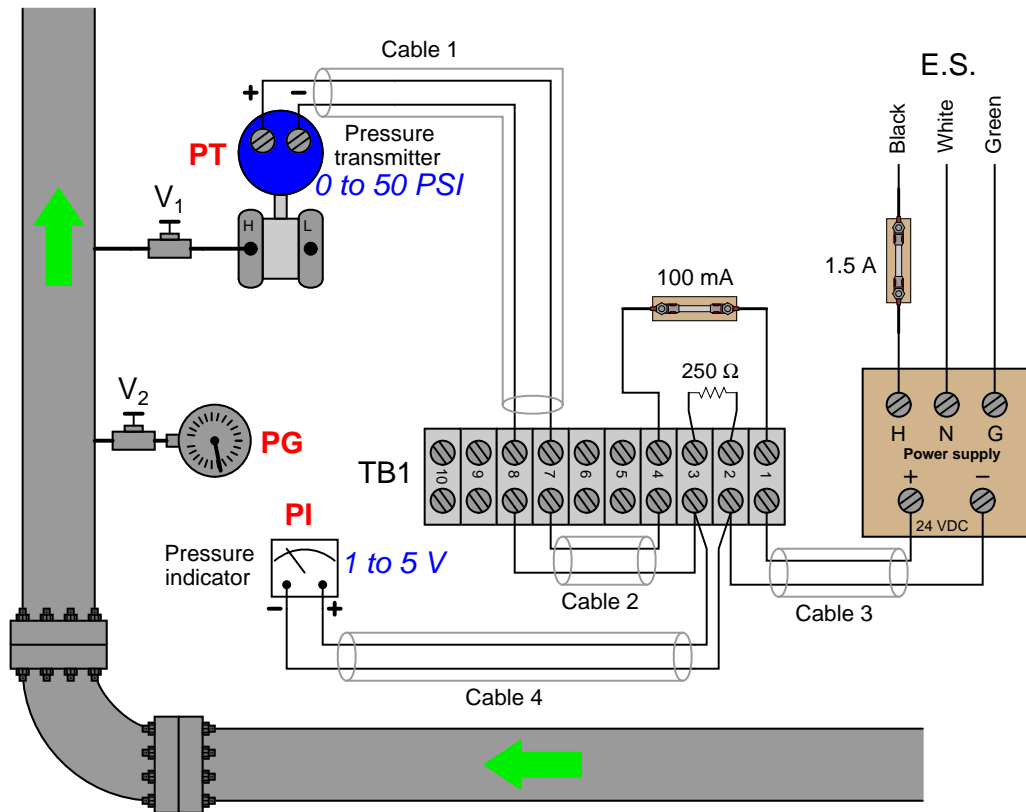

Identify the likelihood of each specified fault for this circuit. Consider each fault one at a time (i.e. no coincidental faults), determining whether or not each fault could independently account for *all* measurements and symptoms in this circuit.

Fault	Possible	Impossible
250 ohm resistor failed open		
100 mA fuse blown		
1.5 A fuse blown		
Cable 1 failed open		
Cable 3 failed open		
Cable 1 failed shorted		
Cable 4 failed shorted		

file i03603

Question 63

Suppose the lamp refuses to light up. A voltmeter registers 24 volts between test points **C** and **D**:

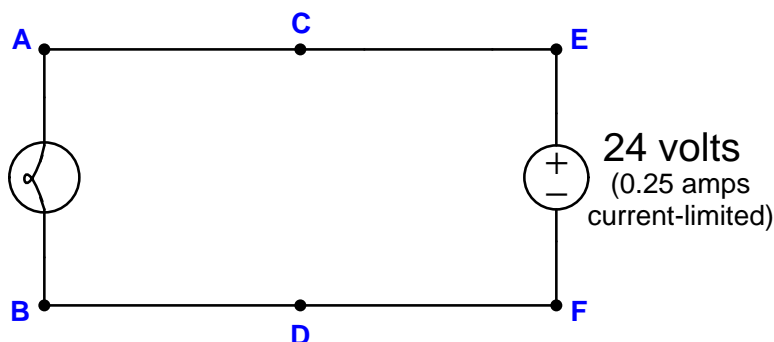

First, list all the possible (single) faults that could account for all measurements and symptoms in this circuit, including failed wires as well as failed components:

Now, determine the diagnostic value of each of the following tests, based on the faults you listed above. If a proposed test could provide new information to help you identify the location and/or nature of the one fault, mark "yes." Otherwise, if a proposed test would not reveal anything relevant to identifying the fault (already discernible from the measurements and symptoms given so far), mark "no."

Diagnostic test	Yes	No
Measure $V_{CF}$		
Measure $V_{ED}$		
Measure $V_{AB}$		
Measure $V_{AD}$		
Measure $V_{CB}$		
Measure $V_{EF}$		
Measure current through wire connecting <b>A</b> and <b>C</b>		
Jumper <b>A</b> and <b>C</b> together		
Jumper <b>B</b> and <b>D</b> together		
Jumper <b>A</b> and <b>B</b> together		

Finally, develop a rule you may use when assessing the value of each proposed test, based on a comprehensive list of possible faults.

**Suggestions for Socratic discussion**

- Identify which fundamental principles of electric circuits apply to each step of your analysis of this circuit. In other words, be prepared to explain the reason(s) "why" for every step of your analysis, rather than merely describing those steps.
- Suppose the fault were intermittent: sometimes the lamp lights up, and other times it goes out. Explain how you could use a digital multimeter (DMM) set to *record* voltage as a troubleshooting tool to determine where the fault is located in the circuit over a span of time too long for you to personally observe the circuit.

[file i01746](#)

Question 64

Suppose the lamp refuses to light up when the pushbutton switch is pressed. A voltmeter registers 0 volts between test points **A** and **D** in the circuit while the pushbutton is pressed:

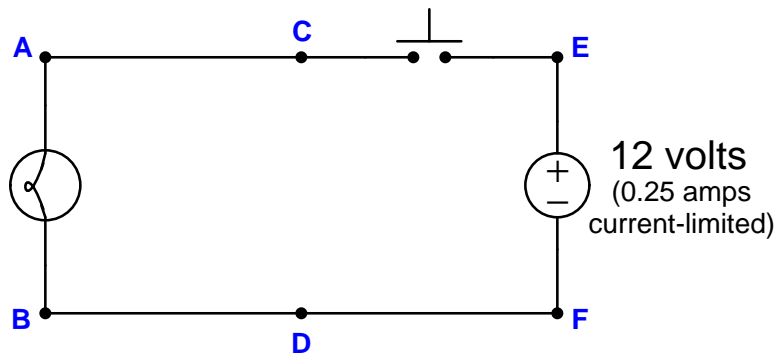

Determine the diagnostic value of each of the following tests. Assume only one fault in the system, including any single component or any single wire/cable/tube connecting components together. If a proposed test could provide new information to help you identify the location and/or nature of the one fault, mark “yes.” Otherwise, if a proposed test would not reveal anything relevant to identifying the fault (already discernible from the measurements and symptoms given so far), mark “no.”

Diagnostic test	Yes	No
Measure $V_{EF}$ with switch pressed		
Measure $V_{CD}$ with switch pressed		
Measure $V_{CB}$ with switch pressed		
Measure $V_{CE}$ with switch pressed		
Measure $R_{AB}$ with switch pressed		
Measure $V_{EF}$ with switch unpressed		
Measure $V_{CD}$ with switch unpressed		
Measure $V_{CB}$ with switch unpressed		
Measure $V_{CE}$ with switch unpressed		
Measure $R_{AB}$ with switch unpressed		



Question 65

Suppose a voltmeter registers 16 volts between test points **C** and **E** in this series-parallel circuit:

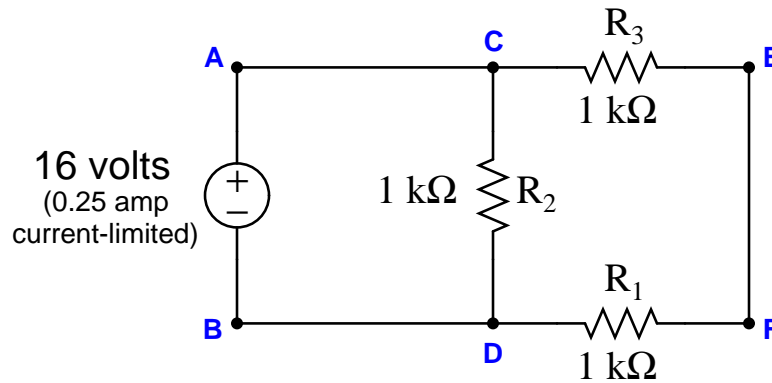

Determine the diagnostic value of each of the following tests. Assume only one fault in the system, including any single component or any single wire/cable/tube connecting components together. If a proposed test could provide new information to help you identify the location and/or nature of the one fault, mark “yes.” Otherwise, if a proposed test would not reveal anything relevant to identifying the fault (already discernible from the measurements and symptoms given so far), mark “no.”

Diagnostic test	Yes	No
Measure $V_{CD}$ with power applied		
Measure $V_{DF}$ with power applied		
Measure $I_{R1}$ with power applied		
Measure $I_{R2}$ with power applied		
Measure $R_{AB}$ with power applied		
Measure $R_{DF}$ with power applied		
Measure $R_{CF}$ with power applied		
Measure $R_{AB}$ with source disconnected from <b>A</b>		
Measure $R_{DF}$ with source disconnected from <b>A</b>		
Measure $R_{CF}$ with source disconnected from <b>B</b>		
Measure $R_{CF}$ with wire disconnected between <b>A</b> and <b>C</b>		

Question 66

Suppose a voltmeter registers 0 volts between test points **A** and **D** in this series-parallel circuit:

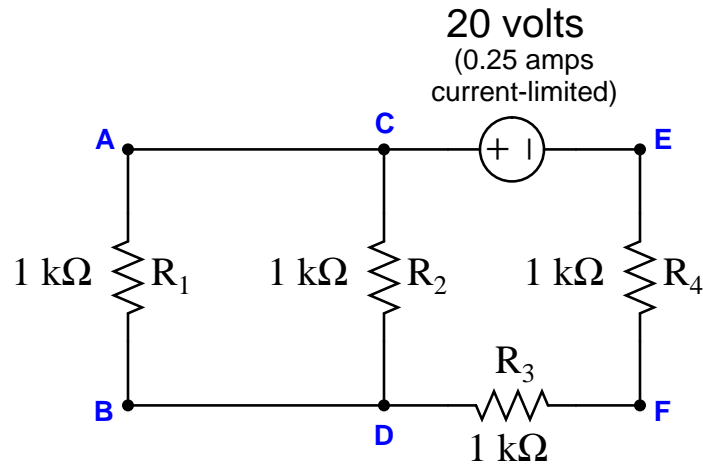

Determine the diagnostic value of each of the following tests. Assume only one fault in the system, including any single component or any single wire/cable/tube connecting components together. If a proposed test could provide new information to help you identify the location and/or nature of the one fault, mark “yes.” Otherwise, if a proposed test would not reveal anything relevant to identifying the fault (already discernible from the measurements and symptoms given so far), mark “no.”

Diagnostic test	Yes	No
Measure $V_{CD}$ with power applied		
Measure $V_{DF}$ with power applied		
Measure $V_{DE}$ with power applied		
Measure $I_{R1}$ with power applied		
Measure $I_{R2}$ with power applied		
Measure $R_{AB}$ with source disconnected from <b>C</b>		
Measure $R_{DF}$ with source disconnected from <b>E</b>		
Measure $R_{CF}$ with source disconnected from <b>C</b>		
Measure $R_{CD}$ with wire disconnected between <b>A</b> and <b>C</b>		
Measure $R_{CD}$ with $R_3$ disconnected from <b>D</b>		

Question 67

Suppose a voltmeter registers 0 volts between test points **E** and **F** in this circuit:

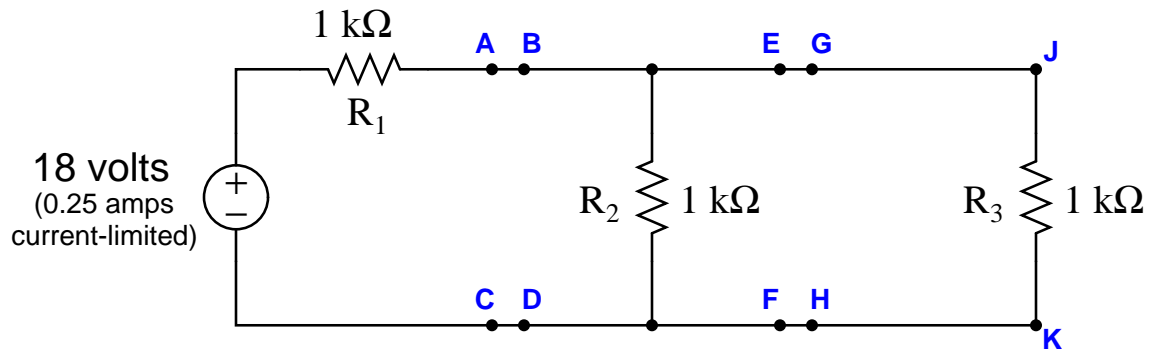

Determine the diagnostic value of each of the following tests. Assume only one fault in the system, including any single component or any single wire/cable/tube connecting components together. If a proposed test could provide new information to help you identify the location and/or nature of the one fault, mark “yes.” Otherwise, if a proposed test would not reveal anything relevant to identifying the fault (already discernible from the measurements and symptoms given so far), mark “no.”

Diagnostic test	Yes	No
Measure $V_{AC}$ with power applied		
Measure $V_{JK}$ with power applied		
Measure $V_{CK}$ with power applied		
Measure $I_{R1}$ with power applied		
Measure $I_{R2}$ with power applied		
Measure $I_{R3}$ with power applied		
Measure $R_{AC}$ with source disconnected from $R_1$		
Measure $R_{DF}$ with source disconnected from $R_1$		
Measure $R_{EG}$ with source disconnected from $R_1$		
Measure $R_{HK}$ with source disconnected from $R_1$		

Question 68

This pictorial diagram shows the wiring connections for a simple pressure control loop, where a loop-powered 4-20 mA pressure transmitter sends a signal to a Honeywell controller, which in turn sends another 4-20 mA signal to a control valve:

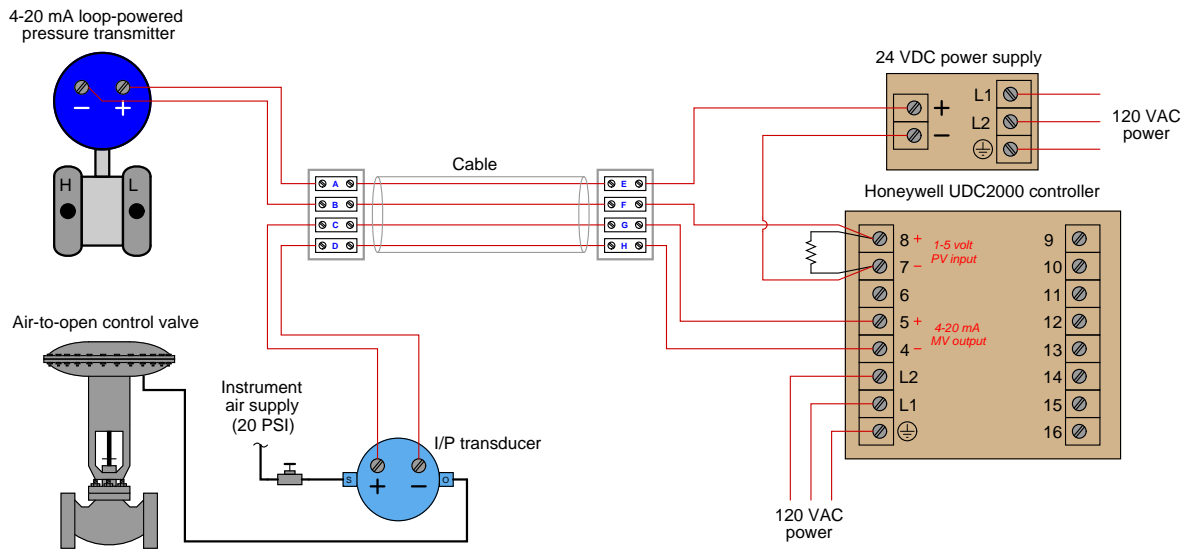

Suppose the operator informs you that the control valve refuses to open, no matter what value she sets the output of the controller in manual mode. Your job now is to diagnose the problem in this control loop using only basic test equipment (e.g. digital multimeter, hand tools).

Determine the diagnostic value of each of the following tests. Assume only one fault in the system, including any single component or any single wire/cable/tube connecting components together. If a proposed test could provide new information to help you identify the location and/or nature of the one fault, mark “yes.” Otherwise, if a proposed test would not reveal anything relevant to identifying the fault (already discernible from the measurements and symptoms given so far), mark “no.”

Diagnostic test	Yes	No
Place controller in automatic mode		
Measure $V_{AB}$ with controller output set to 100% (manual mode)		
Measure $V_{5-4}$ with controller output set to 100% (manual mode)		
Measure $V_{8-7}$ with controller output set to 50% (manual mode)		
“Crack” open tube fitting at the “S” port on the I/P transducer		
“Crack” open tube fitting at the “O” port on the I/P transducer		
Press the I/P transducer’s flapper closer to its nozzle		
Pull the I/P transducer’s flapper away from its nozzle		
Tighten the nuts compressing the control valve’s stem packing		
Loosen the nuts compressing the control valve’s stem packing		
Measure the output voltage of the DC power supply		
Measure voltage across the pressure transmitter terminals		
Measure voltage across the I/P transducer terminals		

file i01298

Question 69

Suppose the electric motor refuses to run when the “Run” pushbutton switch is pressed. A technician begins diagnosing the circuit, following the steps shown (in order):

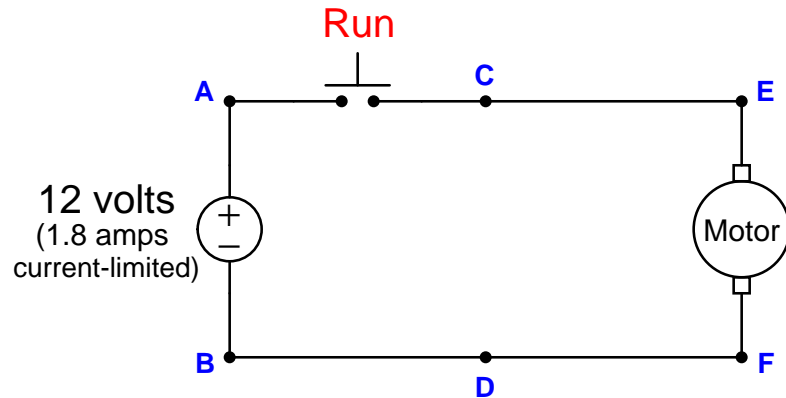

- **Test 1:** Measured 2.8 ohms between points **E** and **F**, with “Run” switch unpressed.
- **Test 2:** Measured 12 volts between points **A** and **F**, with “Run” switch unpressed.
- **Test 3:** Measured 12 volts between points **A** and **B**, with “Run” switch unpressed.
- **Test 4:** Measured 12 volts between points **A** and **C**, with “Run” switch pressed.

Identify any useful information about the nature or location of the fault derived from the results of each test, in order of the tests performed. If the test is not useful (i.e. provides no new information), mark it as such. Assuming there is only one fault in the circuit, identify the location and nature of the fault as precisely as you can from the test results shown above.

Question 70

Suppose the electric motor refuses to run when the “Run” pushbutton switch is pressed. A technician begins diagnosing the circuit, following the steps shown (in order):

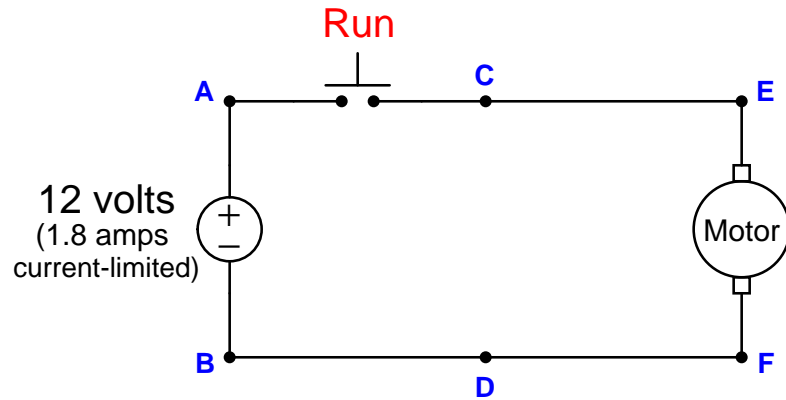

- **Test 1:** Measured 0 volts DC between points C and D, with “Run” switch pressed.
- **Test 2:** Measured 0 volts DC between points A and C, with “Run” switch unpressed.
- **Test 3:** Measured 12 volts DC between points A and B, with “Run” switch pressed.
- **Test 4:** Measured 12 volts DC between points C and B, with “Run” switch unpressed.
- **Test 5:** Measured 3.5 ohms between points E and F, with “Run” switch unpressed.

Identify any useful information about the nature or location of the fault derived from the results of each test, in order of the tests performed. If the test is not useful (i.e. provides no new information), mark it as such. Assuming there is only one fault in the circuit, identify the location and nature of the fault as precisely as you can from the test results shown above.

Question 71

Suppose the electric motor refuses to run when the “Run” pushbutton switch is pressed, whether the speed switch is set to “Fast” or to “Slow.” A technician begins diagnosing the circuit, following the steps shown (in order):

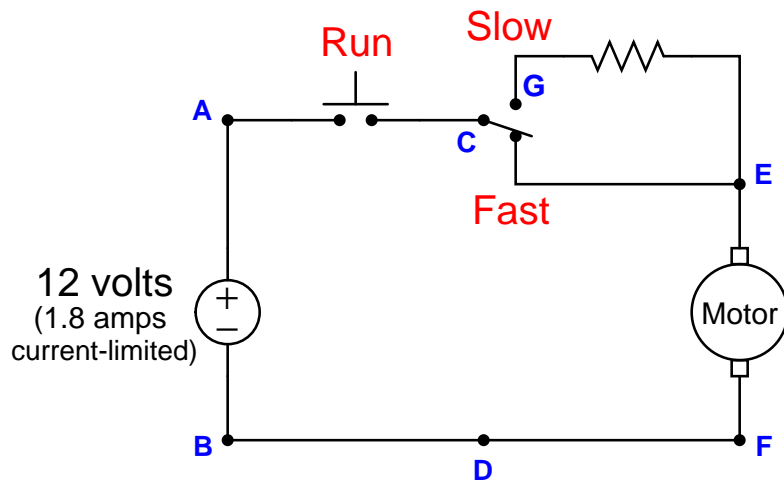

- **Test 1:** Measured 12 volts DC between points **A** and **B**, with “Run” switch pressed and speed switch in “Fast” position.
- **Test 2:** Measured 0 volts DC between points **A** and **C**, with “Run” switch unpressed and speed switch in “Fast” position.
- **Test 3:** Measured 12 volts DC between points **G** and **D**, with “Run” switch pressed and speed switch in “Fast” position.
- **Test 4:** Measured 25 ohms between points **G** and **E**, with “Run” switch unpressed and speed switch in “Fast” position.
- **Test 5:** Measured 12 volts DC between points **A** and **F**, with “Run” switch pressed and speed switch in “Fast” position.

Identify any useful information about the nature or location of the fault derived from the results of each test, in order of the tests performed. If the test is not useful (i.e. provides no new information), mark it as such. Assuming there is only one fault in the circuit, identify the location and nature of the fault as precisely as you can from the test results shown above.

Question 72

This air compressor control circuit has a problem. The air compressor refuses to start even when the air pressure is zero PSI. A technician begins diagnosing the circuit, following the steps shown (in order):

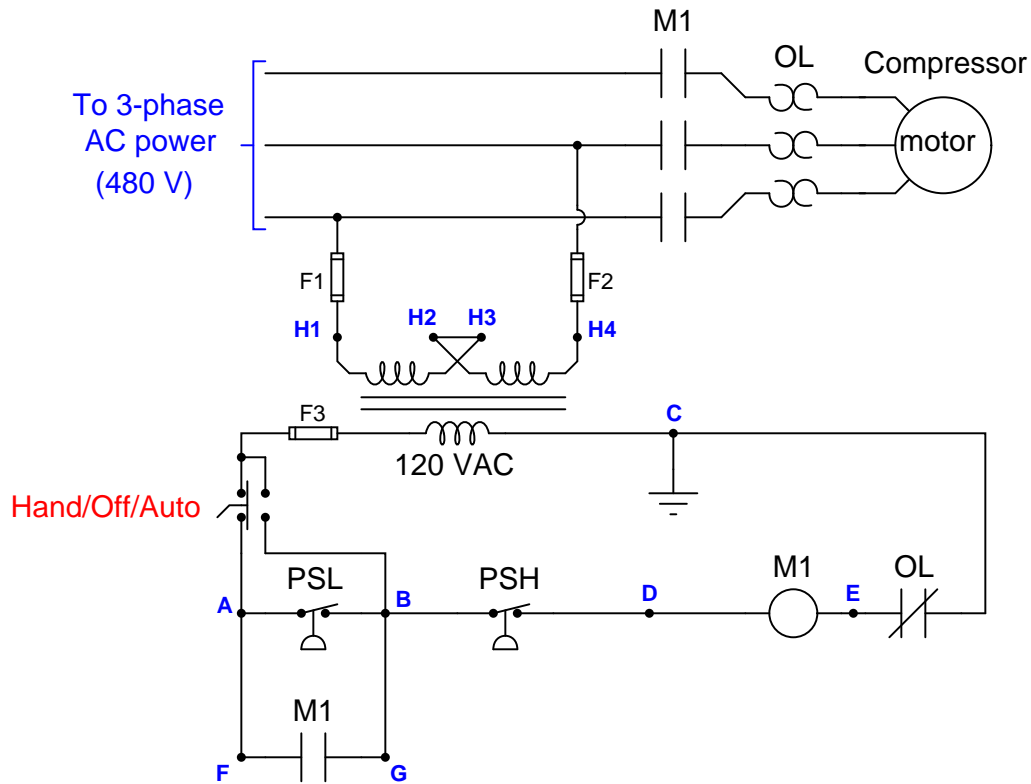

- **Test 1:** Measured 120 VAC between points A and C, with “Hand/Off/Auto” switch in the “Auto” position.
- **Test 2:** Measured 120 VAC between points A and D, with “Hand/Off/Auto” switch in “Auto” position.
- **Test 3:** Measured 0 VAC between points E and C, with “Hand/Off/Auto” switch in “Auto” position.
- **Test 4:** Jumpered points A and B, with “Hand/Off/Auto” switch in “Auto” position. The motor did not start.

Identify any useful information about the nature or location of the fault derived from the results of each test, in order of the tests performed. If the test is not useful (i.e. provides no new information), mark it as such. Assuming there is only one fault in the circuit, identify the location and nature of the fault as precisely as you can from the test results shown above.



Question 73

This conveyor belt control circuit has a problem. The siren energizes when the “Start” pushbutton is pressed, but the conveyor belt never moves. The siren remains energized until the “Stop” button is pressed. A technician begins diagnosing the circuit, following the steps shown (in order). His first action is to press the “Start” switch so that the siren is continuously activated, before he begins any diagnostic tests:

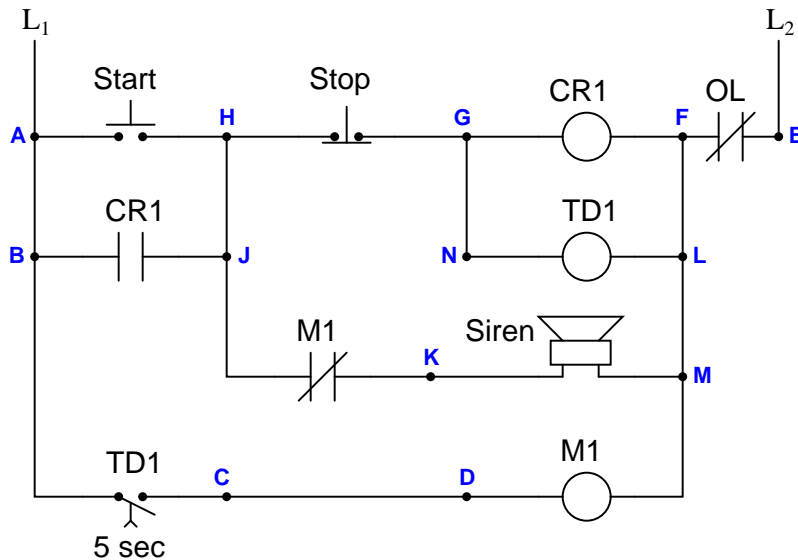

- **Test 1:** Measured 120 VAC between points **A** and **E**.
- **Test 2:** Measured 120 VAC between points **N** and **L**.
- **Test 3:** Measured 0 VAC between points **J** and **K**.
- **Test 4:** Measured 0 VAC between points **D** and **M**.
- **Test 5:** Measured 120 VAC between points **A** and **D**.

Identify any useful information about the nature or location of the fault derived from the results of each test, in order of the tests performed. If the test is not useful (i.e. provides no new information), mark it as such. Assuming there is only one fault in the circuit, identify the location and nature of the fault as precisely as you can from the test results shown above.

Question 74

This reversing motor control circuit has a problem: it runs just fine in reverse, but not at all in the forward direction. A technician begins diagnosing the circuit, following the steps shown (in order):

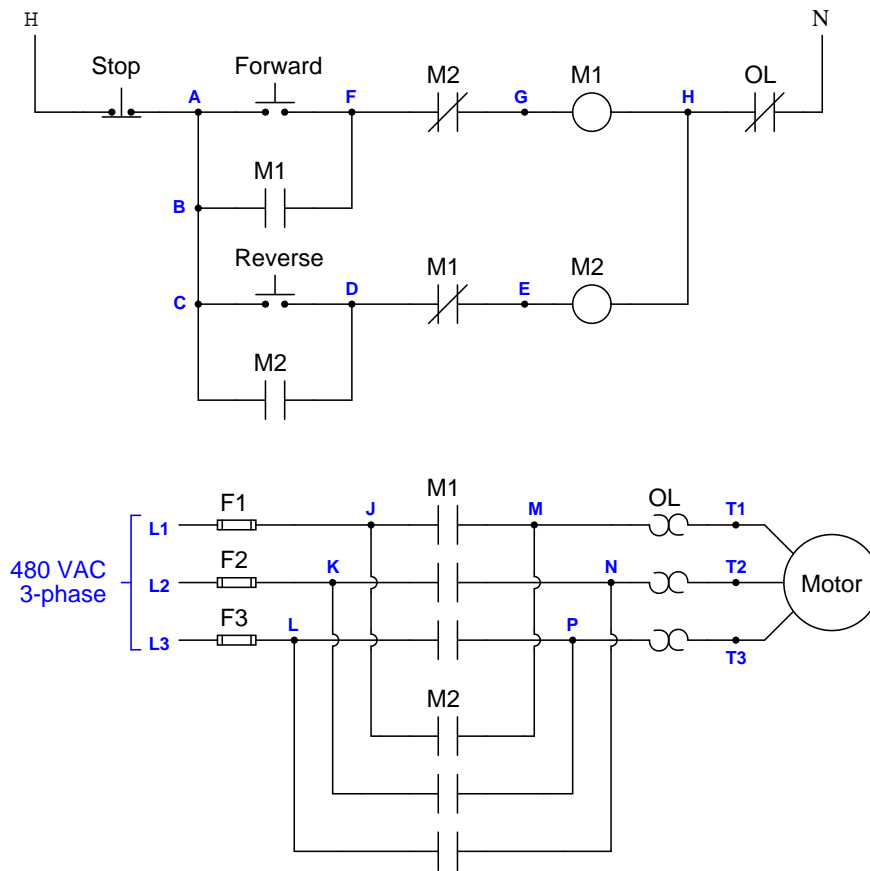

- **Test 1:** Jumpered points **F** and **G** while pressing the “Forward” pushbutton. Motor did not turn.
- **Test 2:** Measured 117 VAC between points **G** and **H** while pressing “Forward” pushbutton.
- **Test 3:** Measured 478 VAC between points **M** and **N** while pressing “Forward” pushbutton.
- **Test 4:** Measured 239 VAC between points **M** and **P** while pressing “Forward” pushbutton.
- **Test 5:** Measured 239 VAC between points **N** and **P** while pressing “Forward” pushbutton.

Identify any useful information about the nature or location of the fault derived from the results of each test, in order of the tests performed. If the test is not useful (i.e. provides no new information), mark it as such. Assuming there is only one fault in the circuit, identify the location and nature of the fault as precisely as you can from the test results shown above.

[file i03532](#)

Question 75

Suppose an operator discovers that the natural gas make-up valve in this fuel gas pressure control system is shut when the controller output is 78%. A technician begins diagnosing the loop, following the steps shown (in order):

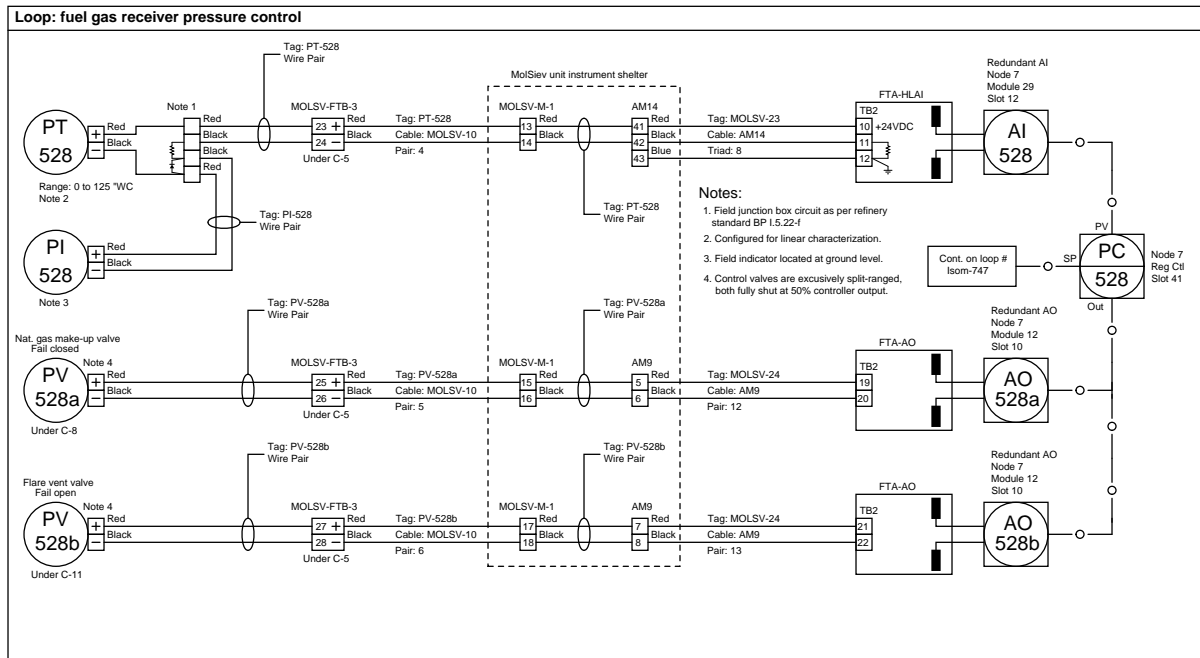

- **Test 1:** Measured 18.6 volts DC between PT-528 transmitter terminals.
- **Test 2:** Measured supply air pressure at PV-528a to be 22 PSIG.
- **Test 3:** Measured 0 volts DC between terminals 25 and 26.
- **Test 4:** Measured 27 volts DC between terminals 5 and 6.
- **Test 5:** Measured 27 volts DC between terminals 19 and 20.
- **Test 6:** Measured 27 volts DC between terminals 15 and 16.

Identify any useful information about the nature or location of the fault derived from the results of each test, in order of the tests performed. If the test is not useful (i.e. provides no new information), mark it as such. Assuming there is only one fault in the circuit, identify the location and nature of the fault as precisely as you can from the test results shown above.

[file i04792](#)

Answer 1

**Rules 1 and 2:** A very bad tendency of novice troubleshooters is to waste time visually looking for that which cannot be seen. Most faults in a system are difficult if not impossible to visually spot. Instead, the proficient troubleshooter always relies on test data and logical reasoning to identify the fault, all the way to the very end.

**Rule 3:** Novice troubleshooters tend to stop prematurely. If you cannot pinpoint the exact nature and location of the fault, either you do not know enough about the subsystem you're trying to diagnose, or you need to continue troubleshooting.

**Rule 4:** Novice troubleshooters tend to ask for others' help prematurely. You are not going to build this vital skill unless and until you are forced to do the thinking on your own!

**Rule 5:** This is nothing more than *Occam's Razor* applied to diagnostics. Single faults are generally more probable than coincidental faults, especially on previously-working systems.

**Rule 6:** Incompetent troubleshooters simply replace all the components they can find until the problem goes away. This is incredibly wasteful, and worse yet does nothing to develop skill.

**Rule 7:** Practice makes perfect. Troubleshooting is a difficult skill to master, and it takes lots of time to develop.

**Rule 8:** Never fool yourself by thinking you have learned something complex just because you have watched someone else do it! Unless and until you have done something yourself, *you don't know it*.

---

Answer 2

Only two out of the four given statements are true:

1. Between two points that are electrically common to each other, there is guaranteed to be zero (or nearly zero) voltage.
4. If voltage is measured between two points, those points cannot be electrically common to each other.

The fundamental concept of logic being applied here may be seen by examining the following statements – representing the same logical pattern of electrical statements given at the beginning of this question:

1. All rabbits are mammals.
2. All mammals are rabbits.
3. All non-rabbits are non-mammals.
4. All non-mammals are non-rabbits.

Clearly, only statements 1 and 4 are true.

---

Answer 3

<b>Fault</b>	<b>Possible</b>	<b>Impossible</b>
Open wire between A and C	✓	
Open wire between B and D		✓
Open wire between D and F	✓	
Lamp failed open		✓
Switch failed open	✓	
Lamp failed shorted	✓	
Switch failed shorted		✓
Voltage source dead	✓	

---

Answer 4

<b>Fault</b>	<b>Possible</b>	<b>Impossible</b>
Open wire between A and C		✓
Open wire between B and D		✓
Open wire between D and F	✓	
Lamp failed open		✓
Switch failed open		✓
Lamp failed shorted	✓	
Switch failed shorted		✓
Voltage source dead	✓	

---

Answer 5

<b>Fault</b>	<b>Possible</b>	<b>Impossible</b>
Open wire between A and C		✓
Open wire between B and D		✓
Open wire between D and F		✓
Lamp failed open		✓
Switch failed open	✓	
Lamp failed shorted	✓	
Switch failed shorted		✓
Voltage source dead		✓

---

Answer 6

<b>Fault</b>	<b>Possible</b>	<b>Impossible</b>
Switch failed open		✓
$R_1$ failed open	✓	
$R_2$ failed open		✓
$R_3$ failed open	✓	
Switch failed shorted		✓
$R_1$ failed shorted		✓
$R_2$ failed shorted		✓
$R_3$ failed shorted		✓
Voltage source dead	✓	

---

Answer 7

<b>Fault</b>	<b>Possible</b>	<b>Impossible</b>
Switch failed open	✓	
$R_1$ failed open		✓
$R_2$ failed open		✓
$R_3$ failed open		✓
Switch failed shorted		✓
$R_1$ failed shorted	✓	
$R_2$ failed shorted		✓
$R_3$ failed shorted		✓
Voltage source dead		✓

---

Answer 8

<b>Fault</b>	<b>Possible</b>	<b>Impossible</b>
$R_1$ failed open	✓	
$R_2$ failed open	✓	
$R_3$ failed open		✓
$R_1$ failed shorted		✓
$R_2$ failed shorted		✓
$R_3$ failed shorted		✓
Voltage source dead		✓

---

Answer 9

<b>Fault</b>	<b>Possible</b>	<b>Impossible</b>
$R_1$ failed open		✓
$R_2$ failed open		✓
$R_3$ failed open		✓
$R_1$ failed shorted		✓
$R_2$ failed shorted		✓
$R_3$ failed shorted	✓	
Voltage source dead		✓

---

Answer 10

<b>Fault</b>	<b>Possible</b>	<b>Impossible</b>
$R_1$ failed open		✓
$R_2$ failed open		✓
$R_3$ failed open	✓	
$R_1$ failed shorted	✓	
$R_2$ failed shorted	✓	
$R_3$ failed shorted		✓
Voltage source dead	✓	

---

Answer 11

<b>Fault</b>	<b>Possible</b>	<b>Impossible</b>
$R_1$ failed open	✓	
$R_2$ failed open	✓	
$R_3$ failed open		✓
$R_1$ failed shorted		✓
$R_2$ failed shorted		✓
$R_3$ failed shorted		✓
Voltage source dead		✓

---

Answer 12

<b>Fault</b>	<b>Possible</b>	<b>Impossible</b>
$R_1$ failed open	✓	
$R_2$ failed open		✓
$R_3$ failed open	✓	
$R_1$ failed shorted		✓
$R_2$ failed shorted	✓	
$R_3$ failed shorted		✓
Voltage source dead	✓	

---

Answer 13

<b>Fault</b>	<b>Possible</b>	<b>Impossible</b>
$R_1$ failed open		✓
$R_2$ failed open	✓	
$R_3$ failed open		✓
$R_1$ failed shorted		✓
$R_2$ failed shorted		✓
$R_3$ failed shorted	✓	
Current source dead		✓

---

Answer 14

<b>Fault</b>	<b>Possible</b>	<b>Impossible</b>
$R_1$ failed open	✓	
$R_2$ failed open	✓	
$R_3$ failed open		✓
$R_1$ failed shorted		✓
$R_2$ failed shorted		✓
$R_3$ failed shorted	✓	
Current source dead	✓	

---

Answer 15

Fault	Possible	Impossible
$R_1$ failed open		✓
$R_2$ failed open	✓	
$R_3$ failed open	✓	
$R_1$ failed shorted		✓
$R_2$ failed shorted		✓
$R_3$ failed shorted		✓
Current source dead		✓

---

Answer 16

The 6 mA current emanating from the current source is supposed to split up into equal parts (3 mA) through resistors  $R_2$  and  $R_3$ . The fact that we measure a full 6 mA in the E-C wire tells us the splitting is not happening as it should. Instead of splitting, we seem to have all the current passing through  $R_3$  with none of it passing through  $R_2$ .

Only two faults could explain this occurring, and that is an open  $R_2$  (preventing current through it) or a shorted  $R_3$  (diverting all current away from  $R_2$ ):

Fault	Possible	Impossible
$R_1$ failed open		✓
$R_2$ failed open	✓	
$R_3$ failed open		✓
$R_1$ failed shorted		✓
$R_2$ failed shorted		✓
$R_3$ failed shorted	✓	
Current source dead		✓

Measuring voltage between points C and D would indicate whether the fault was an open or a short. If open ( $R_2$ ), the voltage should be 6 volts. If shorted ( $R_3$ ), the voltage should be zero volts.

---

Answer 17

Fault	Possible	Impossible
$R_1$ failed open	✓	
$R_2$ failed open		✓
$R_3$ failed open		✓
$R_1$ failed shorted		✓
$R_2$ failed shorted	✓	
$R_3$ failed shorted	✓	
Current source dead	✓	



---

Answer 18

<b>Fault</b>	<b>Possible</b>	<b>Impossible</b>
$R_1$ failed open	✓	
$R_2$ failed open		✓
$R_3$ failed open		✓
$R_1$ failed shorted		✓
$R_2$ failed shorted		✓
$R_3$ failed shorted		✓
Current source dead	✓	

---

Answer 19

<b>Fault</b>	<b>Possible</b>	<b>Impossible</b>
$R_1$ failed open		✓
$R_2$ failed open	✓	
$R_3$ failed open		✓
$R_1$ failed shorted		✓
$R_2$ failed shorted		✓
$R_3$ failed shorted		✓
Current source dead		✓

---

Answer 20

<b>Fault</b>	<b>Possible</b>	<b>Impossible</b>
$R_1$ failed open	✓	
$R_2$ failed open		✓
$R_3$ failed open	✓	
$R_1$ failed shorted		✓
$R_2$ failed shorted		✓
$R_3$ failed shorted		✓
Voltage source dead		✓

---

Answer 21

<b>Fault</b>	<b>Possible</b>	<b>Impossible</b>
$R_1$ failed open	✓	
$R_2$ failed open		✓
$R_3$ failed open		✓
$R_1$ failed shorted		✓
$R_2$ failed shorted		✓
$R_3$ failed shorted	✓	
Voltage source dead		✓

---

Answer 22

<b>Fault</b>	<b>Possible</b>	<b>Impossible</b>
$R_1$ failed open	✓	
$R_2$ failed open		✓
$R_3$ failed open		✓
$R_1$ failed shorted		✓
$R_2$ failed shorted		✓
$R_3$ failed shorted		✓
Voltage source dead		✓

---

Answer 23

<b>Fault</b>	<b>Possible</b>	<b>Impossible</b>
$R_1$ failed open	✓	
$R_2$ failed open	✓	
$R_3$ failed open		✓
$R_1$ failed shorted		✓
$R_2$ failed shorted		✓
$R_3$ failed shorted		✓
Voltage source dead		✓

---

Answer 24

<b>Fault</b>	<b>Possible</b>	<b>Impossible</b>
$R_1$ failed open		✓
$R_2$ failed open		✓
$R_3$ failed open	✓	
$R_1$ failed shorted	✓	
$R_2$ failed shorted	✓	
$R_3$ failed shorted		✓
Voltage source dead		✓

---

Answer 25

<b>Fault</b>	<b>Possible</b>	<b>Impossible</b>
$R_1$ failed open		✓
$R_2$ failed open		✓
$R_3$ failed open	✓	
$R_1$ failed shorted	✓	
$R_2$ failed shorted	✓	
$R_3$ failed shorted		✓
Voltage source dead	✓	

---

Answer 26

<b>Fault</b>	<b>Possible</b>	<b>Impossible</b>
$R_1$ failed open	✓	
$R_2$ failed open		✓
$R_3$ failed open		✓
$R_1$ failed shorted		✓
$R_2$ failed shorted		✓
$R_3$ failed shorted		✓
Current source dead		✓

---

Answer 27

<b>Fault</b>	<b>Possible</b>	<b>Impossible</b>
$R_1$ failed open		✓
$R_2$ failed open	✓	
$R_3$ failed open		✓
$R_1$ failed shorted		✓
$R_2$ failed shorted		✓
$R_3$ failed shorted		✓
Current source dead		✓

---

Answer 28

0 volts between C and E means either no current through that resistor, or it's shorted and cannot drop a voltage.

<b>Fault</b>	<b>Possible</b>	<b>Impossible</b>
$R_1$ failed open		✓
$R_2$ failed open		✓
$R_3$ failed open	✓	
$R_1$ failed shorted	✓	
$R_2$ failed shorted	✓	
$R_3$ failed shorted		✓
Current source dead	✓	

---

Answer 29

<b>Fault</b>	<b>Possible</b>	<b>Impossible</b>
$R_1$ failed open		✓
$R_2$ failed open		✓
$R_3$ failed open		✓
$R_1$ failed shorted	✓	
$R_2$ failed shorted	✓	
$R_3$ failed shorted		✓
Current source dead		✓

---

Answer 30

<b>Fault</b>	<b>Possible</b>	<b>Impossible</b>
$R_1$ failed open	✓	
$R_2$ failed open		✓
$R_3$ failed open	✓	
$R_1$ failed shorted		✓
$R_2$ failed shorted	✓	
$R_3$ failed shorted		✓
Current source dead	✓	

---

Answer 31

<b>Fault</b>	<b>Possible</b>	<b>Impossible</b>
$R_1$ failed open		✓
$R_2$ failed open		✓
$R_3$ failed open	✓	
$R_4$ failed open	✓	
$R_1$ failed shorted	✓	
$R_2$ failed shorted	✓	
$R_3$ failed shorted		✓
$R_4$ failed shorted		✓
Voltage source dead	✓	

---

Answer 32

<b>Fault</b>	<b>Possible</b>	<b>Impossible</b>
$R_1$ failed open		✓
$R_2$ failed open		✓
$R_3$ failed open	✓	
$R_4$ failed open	✓	
$R_1$ failed shorted	✓	
$R_2$ failed shorted	✓	
$R_3$ failed shorted		✓
$R_4$ failed shorted		✓
Voltage source dead		✓

---

Answer 33

<b>Fault</b>	<b>Possible</b>	<b>Impossible</b>
$R_1$ failed open		✓
$R_2$ failed open		✓
$R_3$ failed open	✓	
$R_4$ failed open		✓
$R_1$ failed shorted		✓
$R_2$ failed shorted		✓
$R_3$ failed shorted		✓
$R_4$ failed shorted	✓	
Voltage source dead	✓	

---

Answer 34

<b>Fault</b>	<b>Possible</b>	<b>Impossible</b>
$R_1$ failed open		✓
$R_2$ failed open	✓	
$R_3$ failed open	✓	
$R_4$ failed open	✓	
$R_1$ failed shorted		✓
$R_2$ failed shorted		✓
$R_3$ failed shorted		✓
$R_4$ failed shorted		✓
Voltage source dead		✓

---

Answer 35

<b>Fault</b>	<b>Possible</b>	<b>Impossible</b>
$R_1$ failed open	✓	
$R_2$ failed open		✓
$R_3$ failed open		✓
$R_4$ failed open		✓
$R_1$ failed shorted		✓
$R_2$ failed shorted	✓	
$R_3$ failed shorted		✓
$R_4$ failed shorted		✓
Voltage source dead		✓

---

Answer 36

<b>Fault</b>	<b>Possible</b>	<b>Impossible</b>
$R_1$ failed open	✓	
$R_2$ failed open	✓	
$R_3$ failed open		✓
$R_4$ failed open		✓
$R_1$ failed shorted		✓
$R_2$ failed shorted		✓
$R_3$ failed shorted	✓	
$R_4$ failed shorted	✓	
Voltage source dead		✓

---

Answer 37

<b>Fault</b>	<b>Possible</b>	<b>Impossible</b>
$R_1$ failed open		✓
$R_2$ failed open	✓	
$R_3$ failed open	✓	
$R_4$ failed open	✓	
$R_1$ failed shorted		✓
$R_2$ failed shorted		✓
$R_3$ failed shorted		✓
$R_4$ failed shorted		✓
Current source dead		✓

---

Answer 38

<b>Fault</b>	<b>Possible</b>	<b>Impossible</b>
$R_1$ failed open	✓	
$R_2$ failed open		✓
$R_3$ failed open		✓
$R_4$ failed open		✓
$R_1$ failed shorted		✓
$R_2$ failed shorted		✓
$R_3$ failed shorted		✓
$R_4$ failed shorted		✓
Current source dead		✓

---

Answer 39

<b>Fault</b>	<b>Possible</b>	<b>Impossible</b>
$R_1$ failed open	✓	
$R_2$ failed open		✓
$R_3$ failed open	✓	
$R_4$ failed open	✓	
$R_1$ failed shorted		✓
$R_2$ failed shorted	✓	
$R_3$ failed shorted		✓
$R_4$ failed shorted		✓
Current source dead	✓	

---

Answer 40

<b>Fault</b>	<b>Possible</b>	<b>Impossible</b>
$R_1$ failed open	✓	
$R_2$ failed open	✓	
$R_3$ failed open		✓
$R_4$ failed open		✓
$R_1$ failed shorted		✓
$R_2$ failed shorted		✓
$R_3$ failed shorted		✓
$R_4$ failed shorted		✓
Current source dead	✓	

---

Answer 41

<b>Fault</b>	<b>Possible</b>	<b>Impossible</b>
$R_1$ failed open	✓	
$R_2$ failed open		✓
$R_3$ failed open		✓
$R_1$ failed shorted		✓
$R_2$ failed shorted		✓
$R_3$ failed shorted		✓
Voltage source dead	✓	

---

Answer 42

<b>Fault</b>	<b>Possible</b>	<b>Impossible</b>
$R_1$ failed open		✓
$R_2$ failed open	✓	
$R_3$ failed open		✓
$R_1$ failed shorted		✓
$R_2$ failed shorted		✓
$R_3$ failed shorted		✓
Voltage source dead		✓

---

Answer 43

<b>Fault</b>	<b>Possible</b>	<b>Impossible</b>
$R_1$ failed open		✓
$R_2$ failed open		✓
$R_3$ failed open		✓
$R_4$ failed open		✓
$R_1$ failed shorted		✓
$R_2$ failed shorted	✓	
$R_3$ failed shorted		✓
$R_4$ failed shorted		✓
Voltage source dead		✓

---

Answer 44

<b>Fault</b>	<b>Possible</b>	<b>Impossible</b>
$R_1$ failed open		✓
$R_2$ failed open		✓
$R_3$ failed open		✓
$R_1$ failed shorted		✓
$R_2$ failed shorted		✓
$R_3$ failed shorted	✓	
Voltage source dead		✓

---

Answer 45

<b>Fault</b>	<b>Possible</b>	<b>Impossible</b>
Switch failed open	✓	
$R_1$ failed open		✓
$R_2$ failed open		✓
$R_3$ failed open	✓	
Switch failed shorted		✓
$R_1$ failed shorted	✓	
$R_2$ failed shorted	✓	
$R_3$ failed shorted		✓
Voltage source dead		✓



---

Answer 46

<b>Fault</b>	<b>Possible</b>	<b>Impossible</b>
Switch failed open	✓	
$R_1$ failed open	✓	
$R_2$ failed open		✓
$R_3$ failed open		✓
Switch failed shorted		✓
$R_1$ failed shorted		✓
$R_2$ failed shorted		✓
$R_3$ failed shorted		✓
Voltage source dead		✓

---

Answer 47

<b>Fault</b>	<b>Possible</b>	<b>Impossible</b>
$R_1$ failed open		✓
$R_2$ failed open		✓
$Q_1$ failed open		✓
$R_1$ failed shorted		✓
$R_2$ failed shorted		✓
$Q_1$ failed shorted	✓	
Voltage source dead		✓

---

Answer 48

<b>Fault</b>	<b>Possible</b>	<b>Impossible</b>
$R_1$ failed open		✓
$R_2$ failed open		✓
$Q_1$ failed open		✓
$R_1$ failed shorted	✓	
$R_2$ failed shorted	✓	
$Q_1$ failed shorted		✓
Voltage source dead		✓

---

Answer 49

<b>Fault</b>	<b>Possible</b>	<b>Impossible</b>
$R_1$ failed open	✓	
$R_2$ failed open		✓
$R_3$ failed open		✓
$R_4$ failed open	✓	
$R_1$ failed shorted		✓
$R_2$ failed shorted	✓	
$R_3$ failed shorted	✓	
$R_4$ failed shorted		✓
Voltage source dead		✓

---

Answer 50

<b>Fault</b>	<b>Possible</b>	<b>Impossible</b>
$R_1$ failed open		✓
$R_2$ failed open	✓	
$R_3$ failed open	✓	
$R_4$ failed open		✓
$R_1$ failed shorted	✓	
$R_2$ failed shorted		✓
$R_3$ failed shorted		✓
$R_4$ failed shorted	✓	
Voltage source dead		✓

---

Answer 51

<b>Fault</b>	<b>Possible</b>	<b>Impossible</b>
$R_1$ failed open		✓
$R_2$ failed open		✓
$R_3$ failed open		✓
$R_4$ failed open	✓	
$R_5$ failed open		✓
$R_1$ failed shorted		✓
$R_2$ failed shorted		✓
$R_3$ failed shorted		✓
$R_4$ failed shorted		✓
$R_5$ failed shorted		✓
Voltage source dead		✓

---

Answer 52

<b>Fault</b>	<b>Possible</b>	<b>Impossible</b>
$R_1$ failed open		✓
$R_2$ failed open		✓
$R_3$ failed open		✓
$R_4$ failed open		✓
$R_5$ failed open		✓
$R_1$ failed shorted	✓	
$R_2$ failed shorted		✓
$R_3$ failed shorted		✓
$R_4$ failed shorted		✓
$R_5$ failed shorted		✓
Voltage source dead		✓

---

Answer 53

<b>Fault</b>	<b>Possible</b>	<b>Impossible</b>
Diode $D_1$ failed open		✓
Diode $D_2$ failed open	✓	
Diode $D_3$ failed open	✓	
Diode $D_4$ failed open		✓
Transistor $Q_1$ failed open	✓	
Transistor $Q_2$ failed open	✓	
Transistor $Q_3$ failed open	✓	
Resistor $R_1$ failed open	✓	
Resistor $R_2$ failed open		✓
Resistor $R_3$ failed open	✓	
Resistor $R_4$ failed open		✓
Resistor $R_5$ failed open		✓
Resistor $R_6$ failed open	✓	

---

Answer 54

<b>Fault</b>	<b>Possible</b>	<b>Impossible</b>
Diode $D_1$ failed shorted		✓
Diode $D_2$ failed open	✓	
Diode $D_3$ failed open	✓	
Diode $D_4$ failed open		✓
Transistor $Q_1$ failed open	✓	
Transistor $Q_2$ failed open	✓	
Transistor $Q_3$ failed shorted		✓
Capacitor $C_1$ failed open		✓
Resistor $R_1$ failed shorted		✓
Resistor $R_2$ failed shorted		✓
Resistor $R_3$ failed open	✓	
Resistor $R_4$ failed open		✓
Resistor $R_5$ failed shorted	✓	
Resistor $R_6$ failed open	✓	

---

Answer 55

Fault	Possible	Impossible
PSHH failed open		✓
PSH failed open	✓	
PSL failed open	✓	
“Hand” switch position failed open		✓
“Auto” switch position failed open	✓	
OL contact failed open		✓
Auxiliary “M” contact failed		✓
Contactora “M” coil failed open		✓

The initial test between points **A** and **F** was useless. We already knew from the symptom of the compressor running in “Hand” but not in “Auto” that the fault must be an open, and it must lie between the Hand/Off/Auto switch and test point **A** somewhere. An open fault anywhere between points **A** and **F** would of course drop the full control voltage, so the measurement of 117 volts AC should come as no surprise.

---

Answer 56

Fault	Possible	Impossible
PSHH failed open		✓
PSH failed open		✓
PSL failed open		✓
Auxiliary “M” contact failed open		✓
PSHH failed shorted		✓
PSH failed shorted	✓	
PSL failed shorted		✓
Auxiliary “M” contact failed shorted		✓

---

Answer 57

If the Honeywell controller is pegged downscale, it means the analog input is receiving too little voltage. A failed-open cable anywhere from the controller to the transmitter would do this, as would a dead DC power supply.

No fault in the valve (output) circuit would have any effect on the controller’s indication of pressure, since the valve control circuit is independent of the transmitter circuit.

---

Answer 58

If the Honeywell controller is pegged upscale, it means the analog input is receiving too much voltage. A failed-open resistor would do this, as would any short-circuit bypassing the transmitter.

No fault in the valve (output) circuit would have any effect on the controller’s indication of pressure, since the valve control circuit is independent of the transmitter circuit.

---

Answer 59

If the valve will not open, it means either a mechanical failure is preventing upward motion of the valve stem, or something is preventing air pressure from reaching the valve actuator. Possible faults include either an open or a short in the cable between the I/P and the controller. A dead controller (failed output, or failed AC power supply to the controller) could cause this as well.

Possible non-electrical faults include failed air supply to the I/P, plugged air line between I/P and valve, and a shut block valve at the supply port of the I/P.

No fault in the transmitter (input) circuit would have any effect on the controller's output in manual mode, since the valve control circuit is independent of the transmitter circuit.

---

Answer 60

<b>Fault</b>	<b>Possible</b>	<b>Impossible</b>
250 ohm resistor failed open		✓
100 mA fuse blown	✓	
1.5 A fuse blown	✓	
Cable 1 failed open		✓
Cable 4 failed open		✓
Cable 1 failed shorted		✓
Cable 4 failed shorted		✓

---

Answer 61

<b>Fault</b>	<b>Possible</b>	<b>Impossible</b>
250 ohm resistor failed open	✓	
100 mA fuse blown		✓
1.5 A fuse blown		✓
Cable 1 failed open		✓
Cable 4 failed open		✓
Cable 1 failed shorted	✓	
Cable 4 failed shorted		✓

---

Answer 62

<b>Fault</b>	<b>Possible</b>	<b>Impossible</b>
250 ohm resistor failed open		✓
100 mA fuse blown		✓
1.5 A fuse blown		✓
Cable 1 failed open	✓	
Cable 3 failed open		✓
Cable 1 failed shorted		✓
Cable 4 failed shorted	✓	

---

**Answer 63**

Here is a comprehensive list of faults, each one individually capable of accounting for the symptom (no light) and the measurement of 24 volts between **C** and **D**:

- Lamp burned out (failed open)
- Wire failed open between **A** and **C**
- Wire failed open between **B** and **D**

Based on this short list of possible faults – assuming only *one* of them is actually true – the value of each proposed test is as follows:

<b>Diagnostic test</b>	<b>Yes</b>	<b>No</b>
Measure $V_{CF}$		✓
Measure $V_{ED}$		✓
Measure $V_{AB}$	✓	
Measure $V_{AD}$	✓	
Measure $V_{CB}$	✓	
Measure $V_{EF}$		✓
Measure current through wire connecting <b>A</b> and <b>C</b>		✓
Jumper <b>A</b> and <b>C</b> together	✓	
Jumper <b>B</b> and <b>D</b> together	✓	
Jumper <b>A</b> and <b>B</b> together		✓

A good rule to apply when evaluating proposed tests is to ask the question: “Will this test give me the exact same result no matter which one of the possible faults is true?” If so, the test is useless. If not (i.e. the results would differ depending on which of the possible faults was true), then the test has value because it will help narrow the field of possibilities.

---

**Answer 64**

<b>Diagnostic test</b>	<b>Yes</b>	<b>No</b>
Measure $V_{EF}$ with switch pressed	✓	
Measure $V_{CD}$ with switch pressed	✓	
Measure $V_{CB}$ with switch pressed	✓	
Measure $V_{CE}$ with switch pressed	✓	
Measure $R_{AB}$ with switch pressed	✓	
Measure $V_{EF}$ with switch unpressed	✓	
Measure $V_{CD}$ with switch unpressed		✓
Measure $V_{CB}$ with switch unpressed		✓
Measure $V_{CE}$ with switch unpressed	✓	
Measure $R_{AB}$ with switch unpressed	✓	

---

Answer 65

<b>Diagnostic test</b>	<b>Yes</b>	<b>No</b>
Measure $V_{CD}$ with power applied		✓
Measure $V_{DF}$ with power applied		✓
Measure $I_{R1}$ with power applied	✓	
Measure $I_{R2}$ with power applied		✓
Measure $R_{AB}$ with power applied		✓
Measure $R_{DF}$ with power applied	✓	
Measure $R_{CF}$ with power applied		✓
Measure $R_{AB}$ with source disconnected from <b>A</b>	✓	
Measure $R_{DF}$ with source disconnected from <b>A</b>	✓	
Measure $R_{CF}$ with source disconnected from <b>B</b>	✓	
Measure $R_{CF}$ with wire disconnected between <b>A</b> and <b>C</b>	✓	

Remember, it is *always* useless to measure resistance where there exists significant voltage in a circuit!

---

Answer 66

<b>Diagnostic test</b>	<b>Yes</b>	<b>No</b>
Measure $V_{CD}$ with power applied	✓	
Measure $V_{DF}$ with power applied	✓	
Measure $V_{DE}$ with power applied	✓	
Measure $I_{R1}$ with power applied	✓	
Measure $I_{R2}$ with power applied	✓	
Measure $R_{AB}$ with source disconnected from <b>C</b>	✓	
Measure $R_{DF}$ with source disconnected from <b>E</b>	✓	
Measure $R_{CF}$ with source disconnected from <b>C</b>	✓	
Measure $R_{CD}$ with wire disconnected between <b>A</b> and <b>C</b>		✓
Measure $R_{CD}$ with $R_3$ disconnected from <b>D</b>	✓	

Remember, it is *always* useless to measure resistance where there exists significant voltage in a circuit!

---

Answer 67

<b>Diagnostic test</b>	<b>Yes</b>	<b>No</b>
Measure $V_{AC}$ with power applied	✓	
Measure $V_{JK}$ with power applied		✓
Measure $V_{CK}$ with power applied	✓	
Measure $I_{R1}$ with power applied	✓	
Measure $I_{R2}$ with power applied	✓	
Measure $I_{R3}$ with power applied	✓	
Measure $R_{AC}$ with source disconnected from $R_1$	✓	
Measure $R_{DF}$ with source disconnected from $R_1$	✓	
Measure $R_{EG}$ with source disconnected from $R_1$		✓
Measure $R_{HK}$ with source disconnected from $R_1$		✓

Diagnostic test	Yes	No
Place controller in automatic mode		✓
Measure $V_{AB}$ with controller output set to 100% (manual mode)		✓
Measure $V_{5-4}$ with controller output set to 100% (manual mode)	✓	
Measure $V_{8-7}$ with controller output set to 50% (manual mode)		✓
“Crack” open tube fitting at the “S” port on the I/P transducer	✓	
“Crack” open tube fitting at the “O” port on the I/P transducer	✓	
Press the I/P transducer’s flapper closer to its nozzle	✓	
Pull the I/P transducer’s flapper away from its nozzle		✓
Tighten the nuts compressing the control valve’s stem packing		✓
Loosen the nuts compressing the control valve’s stem packing		?
Measure the output voltage of the DC power supply		✓
Measure voltage across the pressure transmitter terminals		✓
Measure voltage across the I/P transducer terminals	✓	

Loosening the nuts on the control valve’s stem packing is a questionable test because control valve actuators generally exert sufficient force to overcome even the worst cases of stem packing friction. Thus, it is highly unlikely that stem packing friction is the cause of the valve’s unresponsiveness, and as such this test should be avoided unless it is determined that the valve actuating diaphragm is indeed receiving full air pressure from the I/P.

- **Test 1:** Measured 2.8 ohms between points **E** and **F**, with “Run” switch unpressed. *Proves that the motor is not open, and likely not shorted either.*
- **Test 2:** Measured 12 volts between points **A** and **F**, with “Run” switch unpressed. *Proves that the source is not dead, and that the wires connecting B to D to F are all good.*
- **Test 3:** Measured 12 volts between points **A** and **B**, with “Run” switch unpressed. *This is an unnecessary test, as we already know the source is not dead.*
- **Test 4:** Measured 12 volts between points **A** and **C**, with “Run” switch pressed. *Proves that the switch is failed open, as it should drop 0 volts when pressed!*

**The fault is an “open” pushbutton switch.**



---

Answer 70

- **Test 1:** Measured 0 volts DC between points **C** and **D**, with “Run” switch pressed. *Proves that the problem is to the left of these test points (toward the source). Most likely either a dead source or an “open” fault.*
- **Test 2:** Measured 0 volts DC between points **A** and **C**, with “Run” switch unpressed. *Proves the problem is not the switch (assuming only one fault).*
- **Test 3:** Measured 12 volts DC between points **A** and **B**, with “Run” switch pressed. *Proves the source is not dead.*
- **Test 4:** Measured 12 volts DC between points **C** and **B**, with “Run” switch unpressed. *This is an unnecessary test, as we already know the source is not dead and the switch is not failed open.*
- **Test 5:** Measured 3.5 ohms between points **E** and **F**, with “Run” switch unpressed. *This is an unnecessary test, as we already know the fault does not lie with the motor (assuming a single fault).*

**The fault is an “open,” between points B and D.**

---

Answer 71

- **Test 1:** Measured 12 volts DC between points **A** and **B**, with “Run” switch pressed and speed switch in “Fast” position. *Proves that the source is not dead.*
- **Test 2:** Measured 0 volts DC between points **A** and **C**, with “Run” switch unpressed and speed switch in “Fast” position. *Proves that the “Run” switch is not failed open (assuming only one fault).*
- **Test 3:** Measured 12 volts DC between points **G** and **D**, with “Run” switch pressed and speed switch in “Fast” position. *Eliminates any “open” faults except for the motor and the wire between D and F – fault must be in either of those two locations.*
- **Test 4:** Measured 25 ohms between points **G** and **E**, with “Run” switch unpressed and speed switch in “Fast” position. *This is an unnecessary test, because we already knew the resistor was not failed open from test 3, and also because we know that the fault must be common to both speed switch positions and not just one (since the motor refuses to run in either the “Fast” or the “Slow” position).*
- **Test 5:** Measured 12 volts DC between points **A** and **F**, with “Run” switch pressed and speed switch in “Fast” position. *Proves the wire from D to F is not open. Combined with the results of previous tests, we can only conclude that the fault must lie within the motor.*

**The fault is an “open” electric motor.**

---

Answer 72

- **Test 1:** Measured 120 VAC between points **A** and **C**, with “Hand/Off/Auto” switch in the “Auto” position. *Proves there is 120 VAC control power available, that the fuse is good, and that the Hand/Off/Auto switch is passing power through to point A.*
- **Test 2:** Measured 120 VAC between points **A** and **D**, with “Hand/Off/Auto” switch in “Auto” position. *Proves there is an “open” fault somewhere between those points, in one of the two switches, and that we do not have any other “open” faults in the contactor coil circuit.*
- **Test 3:** Measured 0 VAC between points **E** and **C**, with “Hand/Off/Auto” switch in “Auto” position. *This is an unnecessary test, as we already know there is continuity through the overload contact.*
- **Test 4:** Jumpered points **A** and **B**, with “Hand/Off/Auto” switch in “Auto” position. The motor did not start. *Combined with the results of previous tests, this test proves the “open” fault must lie between points B and D: namely the PSH.*

**The fault is an “open” high pressure switch (PSH), or in the wires connecting the PSH to points B and D.**

---

Answer 73

- **Test 1:** Measured 120 VAC between points **A** and **E**. *This is an unnecessary test, as we already know there is 120 VAC power available to the control circuit (otherwise, the siren would never energize).*
- **Test 2:** Measured 120 VAC between points **N** and **L**. *This confirms the time-delay relay coil is receiving power, limiting the fault to either an “open” TD1 coil, or an “open” somewhere between points B and M.*
- **Test 3:** Measured 0 VAC between points **J** and **K**. *This is an unnecessary test, as we already know NC contact M1 is closed, because the siren is being energized.*
- **Test 4:** Measured 0 VAC between points **D** and **M**. *This proves no power is getting to the M1 contactor coil, indicating an “open” fault somewhere between B and M other than the coil itself.*
- **Test 5:** Measured 120 VAC between points **A** and **D**. *This test alone proves an “open” fault must exist between points A and D. Combined with knowledge that the siren is latching on, we know the “open” fault cannot lie between A and B, and therefore must lie somewhere between B and D.*

**The fault is an “open,” either between B and contact TD1, at contact TD1 itself, or between points C and D.**

- **Test 1:** Jumpered points **F** and **G** while pressing the “Forward” pushbutton. Motor does not turn. *While not a very efficient test, it does prove the problem is not an “open” M2 auxiliary contact.*
- **Test 2:** Measured 117 VAC between points **G** and **H** while pressing “Forward” pushbutton. *This proves the M1 coil is indeed receiving control power when it should. Potential faults include an “open” M1 coil, or an “open” fault in the M1 power contacts. This would have been a good first test!*
- **Test 3:** Measured 478 VAC between points **M** and **N** while pressing “Forward” pushbutton. *Proves at those two power contacts are closing as they should.*
- **Test 4:** Measured 239 VAC between points **M** and **P** while pressing “Forward” pushbutton. *Proves we do not have a good connection to line L3 through the third contact in the three-phase contactor. The reduced voltage (239 volts versus 478 volts) is due to the motor’s three-phase stator winding acting as a voltage divider, splitting the single-phase 478 VAC reading into two halves ( $V_{MP}$  and  $V_{NP}$ ).*
- **Test 5:** Measured 239 VAC between points **N** and **P** while pressing “Forward” pushbutton. *Proves again that we do not have a good connection to line L3 through the third contact. Strictly speaking, this test is unnecessary. However, since the conclusion drawn from Test 4 is not that obvious, this test would not be a bad idea simply to clarify the fact that the 478 VAC reading between M and N is being split in half.*

**The fault is an “open” between L and P (one of the power contacts within contactor M1).**

---

- **Test 1:** Measured 18.6 volts DC between PT-528 transmitter terminals. *Proves nothing that is helpful in diagnosing the valve problem. We know the transmitter has adequate power to function, but this tells us nothing about why the make-up valve refuses to open.*
- **Test 2:** Measured supply air pressure at PV-528a to be 22 PSIG. *Proves that the air supply to the make-up valve is good (needs to be more than 15 PSI for a 3-15 PSI bench-set valve). However, we don’t know anything more about the fault other than the fact it isn’t this one thing.*
- **Test 3:** Measured 0 volts DC between terminals 25 and 26. *Proves the fault is electrical in nature: either an “open” between these terminals and the DCS output, or a “short” potentially anywhere in this cable (or in the I/P) for valve PV-528a.*
- **Test 4:** Measured 27 volts DC between terminals 5 and 6. *Proves the fault must be an “open” somewhere between these terminals and terminals 25-26.*
- **Test 5:** Measured 27 volts DC between terminals 19 and 20. *This is an unnecessary test, as we already know there will be full voltage here, since points “downstream” of these (i.e. closer to the load) have full voltage.*
- **Test 6:** Measured 27 volts DC between terminals 15 and 16. *Proves the fault must be an “open” between these terminals and terminals 25-26.*

**The fault is an “open” in wire pair 5 of cable MOLSV-10, or at the connection point between one of these wires and the terminal block.**