

Transformer circuit calculations

This worksheet and all related files are licensed under the Creative Commons Attribution License, version 1.0. To view a copy of this license, visit <http://creativecommons.org/licenses/by/1.0/>, or send a letter to Creative Commons, 559 Nathan Abbott Way, Stanford, California 94305, USA. The terms and conditions of this license allow for free copying, distribution, and/or modification of all licensed works by the general public.

Questions

Question 1

If an *isolation transformer* (a transformer with the same number of “turns” in the primary and secondary coils) is connected between an AC source and an AC load, we will measure the same voltage and the same current at both source and load terminals:

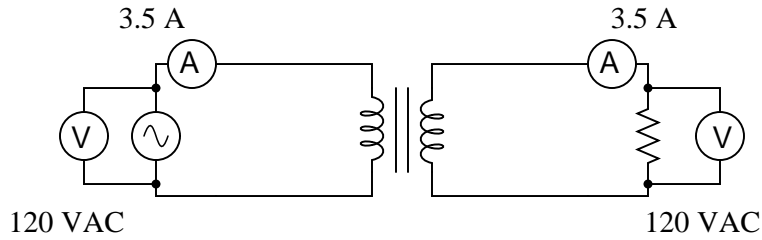

If we calculate power output by the source and power dissipated by the load, the value is the same: 420 Watts ($P = IV$).

Now suppose we analyze a circuit containing a *step-up transformer* (one with more turns of wire in the secondary coil than in the primary coil). With a step-up transformer, the load voltage will be greater than the supply voltage. In this example, I show a step-up transformer with a 1:2 step ratio:

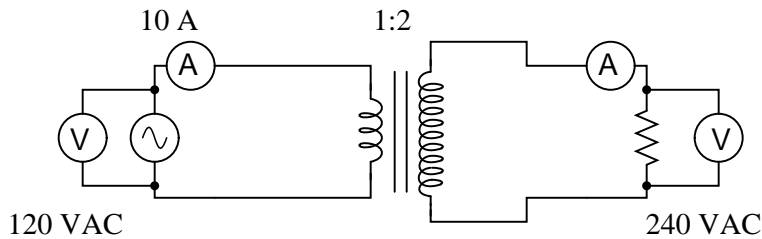

Assuming the load resistance is completely different from the first (isolation transformer) circuit, what can you deduce about the load current and the power (both source and load) in this circuit? Is the load current less than the source current? Is the load current greater than the source current? Is the load power greater than the source power? Explain your answers.

[file i01253](#)

Question 2

Industrial *control power transformers* are used to step down 480 or 240 volts to a level more acceptable for relay control circuitry: usually 120 volts. Some control power transformers are built with multiple primary windings, to facilitate connection to either a 480 volt or 240 volt AC power source:

240 × 480 primary

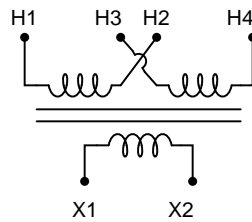

120 secondary

Such transformers are usually advertised as having “240 × 480” primary windings, the “×” symbol representing two independent windings with four connection points (H1 through H4).

Show the connections on the four “H” terminals necessary for 240 volt operation, and also for 480 volt operation, on the following illustrations:

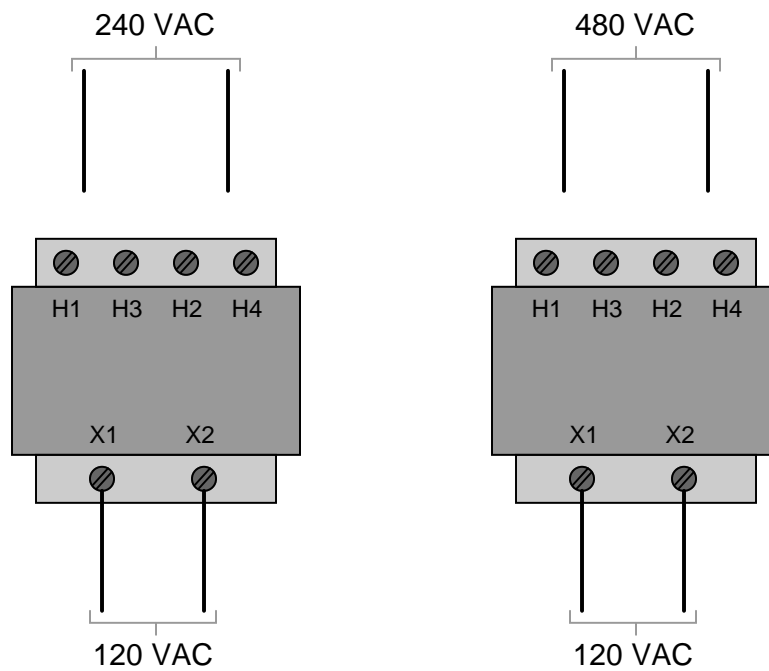

[file i01259](#)

Question 3

Calculate all listed values for this transformer circuit:

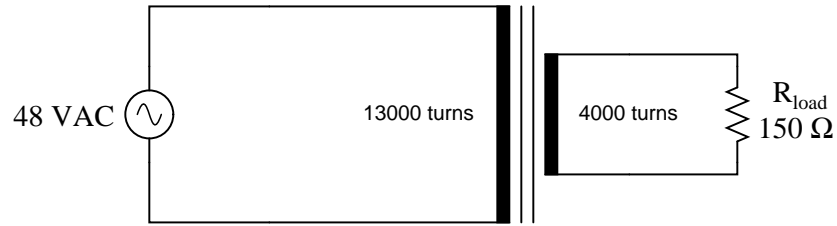

- $V_{primary} =$
- $V_{secondary} =$
- $I_{primary} =$
- $I_{secondary} =$

Explain whether this is a *step-up*, *step-down*, or *isolation* transformer, and also explain what distinguishes the “primary” winding from the “secondary” winding in any transformer.
[file i01256](#)

Question 4

Calculate the load current and load voltage in this transformer circuit:

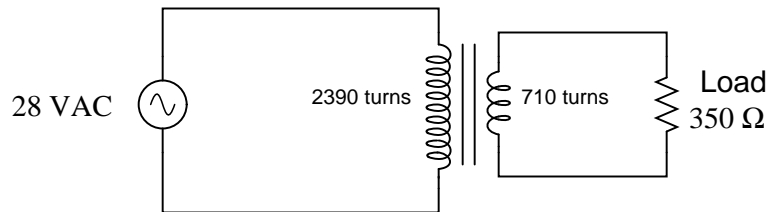

$I_{load} =$

$V_{load} =$

[file i01254](#)

Question 5

Calculate the source current and load current in this transformer circuit:

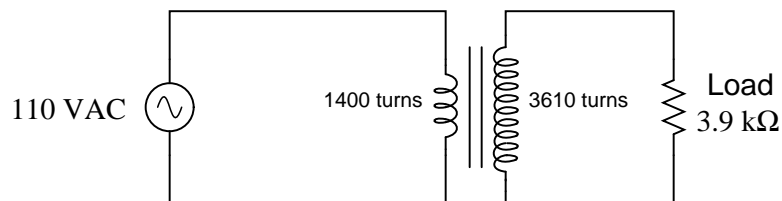

$I_{source} =$

$I_{load} =$

[file i01255](#)

Question 6

Calculate all voltages and all currents in this circuit, given the component values and the number of turns in each of the transformer's windings:

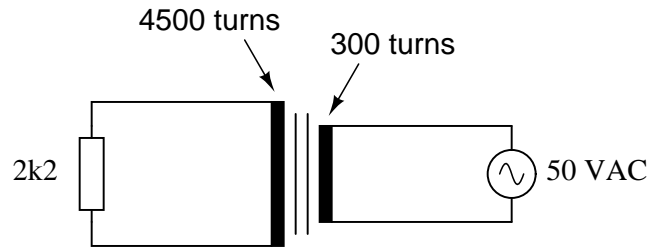

[file i01239](#)

Question 7

Calculate all voltages and all currents in this transformer circuit, assuming the 170 ohm resistor carries a current of 5.8 mA:

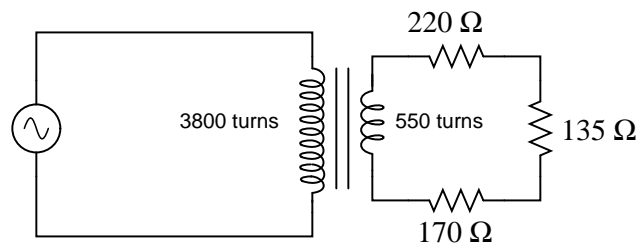

- $V_{primary} =$
- $V_{secondary} =$
- $I_{primary} =$
- $I_{secondary} =$

[file i01267](#)

Question 8

Calculate all voltages and all currents in this transformer circuit, assuming the 5 ohm resistor carries a current of 10 amps:

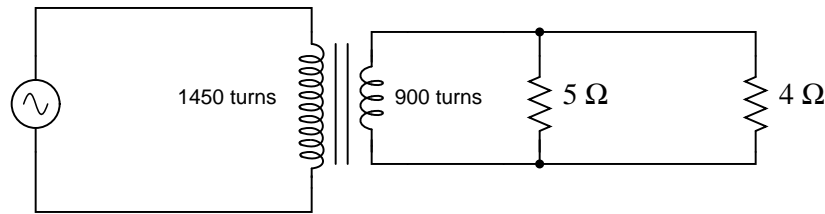

- $V_{primary} =$
- $V_{secondary} =$
- $I_{primary} =$
- $I_{secondary} =$

[file i01269](#)

Question 9

Calculate all voltages and all currents in this transformer circuit, assuming the 3.3 kΩ resistor drops 40 volts:

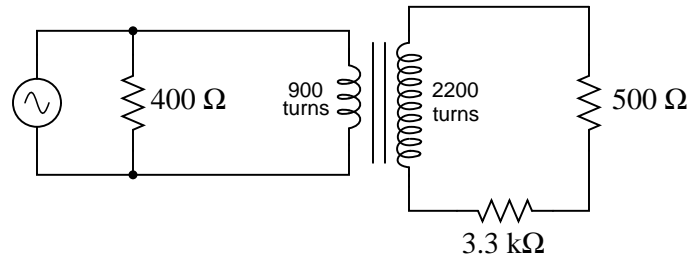

- $V_{source} =$
- $V_{primary} =$
- $V_{secondary} =$
- $I_{source} =$
- $I_{primary} =$
- $I_{secondary} =$

[file i01271](#)

Question 10

Calculate all voltages and all currents in this transformer circuit, assuming the $3.3\text{ k}\Omega$ resistor drops 13 volts:

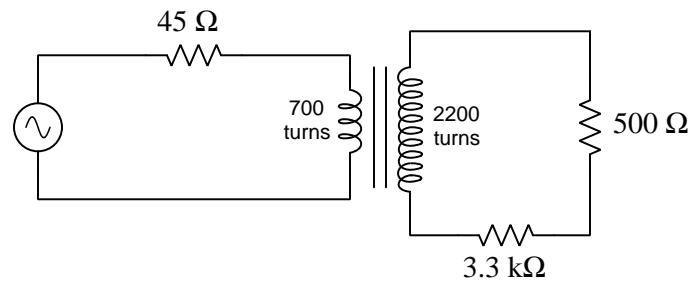

- $V_{source} =$
- $V_{primary} =$
- $V_{secondary} =$
- $I_{source} =$
- $I_{primary} =$
- $I_{secondary} =$

file i01273

Question 11

Suppose a power system were delivering AC power to a resistive load drawing 150 amps:

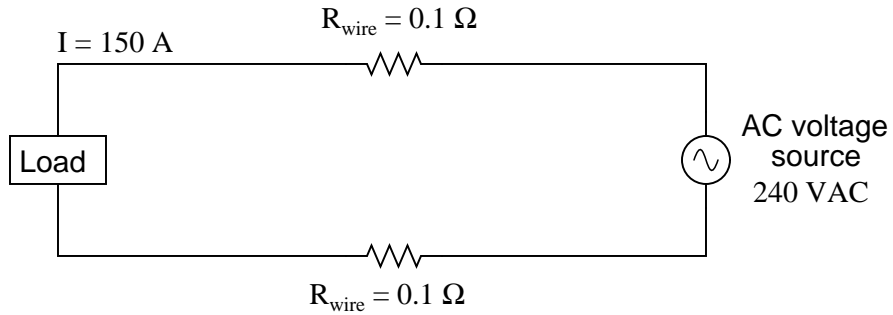

Calculate the load voltage, load power dissipation, the power dissipated by the wire resistance (R_{wire}), and the overall power efficiency ($\eta = \frac{P_{\text{load}}}{P_{\text{source}}}$).

$$E_{\text{load}} =$$

$$P_{\text{load}} =$$

$$P_{\text{lines}} =$$

$$\eta =$$

Now, suppose we were to use a pair of perfectly efficient 10:1 transformers to step the voltage up for transmission, and back down again for use at the load. Re-calculate the load voltage, load power, wasted power, and overall efficiency of this system:

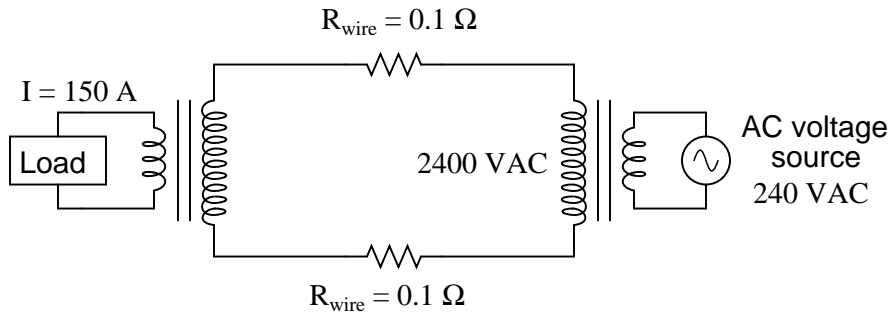

$$E_{\text{load}} =$$

$$P_{\text{load}} =$$

$$P_{\text{lines}} =$$

$$\eta =$$

[file i01258](#)

Question 12

How much current will be output by a current transformer if the load current is 350 amps and the CT ratio is 600:5?

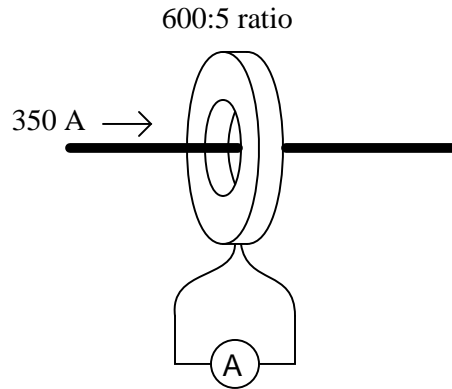

file i01260

Question 13

Calculate the primary winding current (magnitude and phase angle) for this resistively loaded isolation transformer, with primary and secondary inductances of 18 Henrys each:

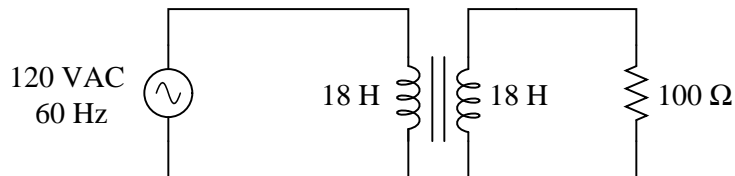

Also, draw an equivalent schematic diagram (with no transformer in it) illustrating the impedance “seen” by the AC power source. Assume no winding resistance in either transformer winding, and a magnetic coupling coefficient between the two windings of exactly 1.

file i01252

Answers

Answer 1

The basic physical law known as *The Law of Conservation of Energy* tells us that power cannot come from nowhere, or disappear into nowhere. If the power source is sending 420 watts into the transformer, then the load must be receiving 420 watts (neglecting any inefficiencies internal to the transformer). The transformer's step ratio is completely irrelevant as far as *power* is concerned!

For a real transformer (with less than 100% efficiency), the load will receive slightly less than 420 watts of power, the remainder converted into heat at the transformer.

Answer 2

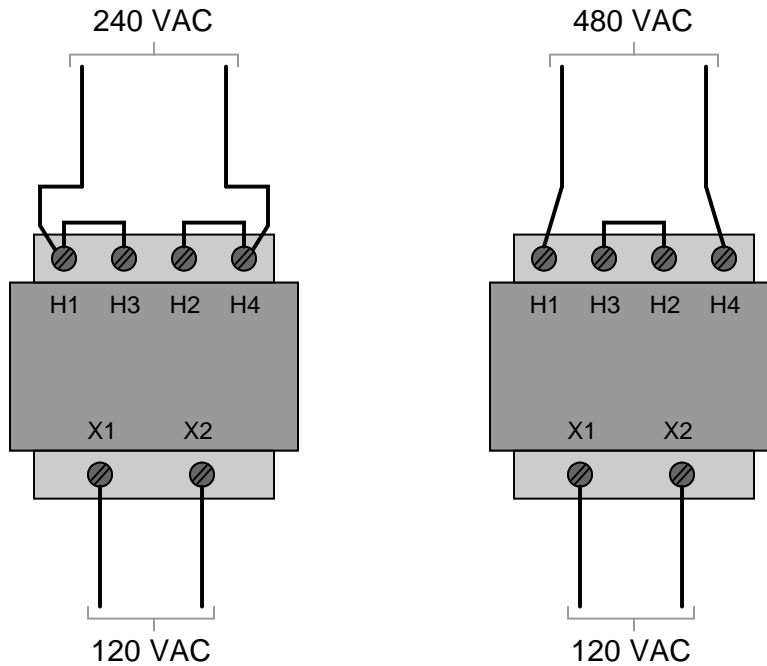

Answer 3

- $V_{primary} = 48$ volts
- $V_{secondary} = 14.77$ volts
- $I_{primary} = 30.3$ mA
- $I_{secondary} = 98.5$ mA

This is a *step-down* transformer.

Answer 4

$$I_{load} = 23.77 \text{ mA}$$

$$V_{load} = 8.318 \text{ V}$$

Answer 5

$$I_{source} = 187.5 \text{ mA}$$

$$I_{load} = 72.73 \text{ mA}$$

Answer 6

$$V_R = 750 \text{ V}$$

$$I_R = 340.9 \text{ mA}$$

$$V_{source} = 50 \text{ V}$$

$$I_{source} = 5.114 \text{ A}$$

Answer 7

- $V_{primary} = 21.04 \text{ volts}$
 - $V_{secondary} = 3.045 \text{ volts}$
 - $I_{primary} = 839.5 \text{ microamps}$
 - $I_{secondary} = 5.8 \text{ milliamps}$
-

Answer 8

- $V_{primary} = 80.56 \text{ volts}$
 - $V_{secondary} = 50 \text{ volts}$
 - $I_{primary} = 13.97 \text{ amps}$
 - $I_{secondary} = 22.5 \text{ amps}$
-

Answer 9

- $V_{source} = 18.84 \text{ V}$
 - $V_{primary} = 18.84 \text{ V}$
 - $V_{secondary} = 46.06 \text{ V}$
 - $I_{source} = 76.74 \text{ mA}$
 - $I_{primary} = 29.63 \text{ mA}$
 - $I_{secondary} = 12.12 \text{ mA}$
-

Answer 10

- $V_{source} = 5.32 \text{ V}$
 - $V_{primary} = 4.763 \text{ V}$
 - $V_{secondary} = 14.97 \text{ V}$
 - $I_{source} = 12.38 \text{ mA}$
 - $I_{primary} = 12.38 \text{ mA}$
 - $I_{secondary} = 3.939 \text{ mA}$
-

Answer 11

Simple system (no transformers):

$$E_{load} = 210 \text{ volts}$$

$$P_{load} = 31.5 \text{ kW}$$

$$P_{lines} = 4.5 \text{ kW}$$

$$\eta = 87.5\%$$

Complex system (with transformers):

$$E_{load} = 239.7 \text{ volts}$$

$$P_{load} = 35.96 \text{ kW}$$

$$P_{lines} = 45 \text{ W}$$

$$\eta = 99.88\%$$

Answer 12

Secondary current = 2.917 amps

Answer 13

$$I_{primary} = 1.2001 \text{ A } \angle -0.84^\circ$$

Equivalent (transformerless) circuit

