

APOLLO

E-2065

[Handwritten signature]
BLOCK II AGC SELF-CHECK AND SHOW-BANKSUM

by

Edwin D. Smally

December 1966

MIT

CAMBRIDGE 39, MASSACHUSETTS

ACKNOWLEDGEMENT

This report was prepared under DSR Project 55-23850, sponsored by the Manned Spacecraft Center of the National Aeronautics and Space Administration through Contract NAS 9-4065.

The publication of the report does not constitute approval by the National Aeronautics and Space Administration of the findings or the conclusions contained therein. It is published only for the exchange and stimulation of ideas.

ADDENDUM 1

E-2065

BLOCK II AGC SELF-CHECK AND SHOW-BANKSUM

by

E. D. Smally
December 1966

The SELF-CHECK routine as found in Sunburst 206 is essentially as described in E-2065 with the exceptions noted below.

A. Initialization of SELF-CHECK Reserved Erasable

Fresh Start does not clear SFAIL or ERCOUNT. ERESTORE is cleared by Fresh Start. Restart does not clear SFAIL.

It may be desirable to clear ERCOUNT, by keyboard, after doing Verb Fresh Start.

B. Alarm Display

A SELF-CHECK initiated program alarm turns on the program alarm light and displays the FAILREG set (Noun 50). The FAILREG set, (FAILREG, FAILREG +1, FAILREG +2), displays the alarm codes of the first, next to last, and last program failure. The alarm code for SELF-CHECK is still 01102. If additional information is desired, the operator may display Noun 31, the ALMCADR set, (ALMCADR, ALMCADR +1, ERCOUNT). The contents of ALMCADR, if SELF-CHECK was the last failure, is equal to 1 + address of the failure (the contents of SFAIL), ALMCADR +1 the contents of BBANK for SELF-CHECK (76002), and ERCOUNT the number of SELF-CHECK failures since ERCOUNT was last cleared. If the contents of ALMCADR +1 is not 76002, due to an intervening failure by a program other than SELF-CHECK, the contents of SFAIL (machine address 01357) could then be displayed directly.

C. ERASCHK

This part of SELF-CHECK makes sure that it is possible to read a "1" and a "0" into and out of each bit position of erasable memory.

In the event that a RESTART occurs in the midst of ERASCHK, the RESTART subroutine does a FRESH START if a set of erasable registers were being checked. The reason for the FRESH START is that ERASCHK has just contaminated two erasable registers, and the EBANK information needed to identify and restore them has been destroyed by the lead in to the RESTART program (this problem has been corrected in the 258 mission program). The RESTART program tests register ERESTORE and if ZERO, proceeds with RESTART, otherwise it goes to DOFSTART (program FRESH START).

The non-special erasable registers are checked for correct addressing and content by placing their own address in two successive registers and making sure there is a difference of -1 when the contents of the lower address register is added to the complement of the higher address register; if it is not, this subroutine performs a TC to the PRERORS subroutine. The previous contents of the erasable registers had been preserved and are restored to the two registers by PRERORS which then performs a TC to the Errors subroutine.

If the difference is -1, the contents of the two registers are complemented and the complement of the lower register added to the contents of the higher register; the result is checked for -1. If the result is not -1, TC to PRERORS as noted above. If the result is -1, restore the previous contents to the two registers, and proceed to the next iteration. The higher address register of the past iteration becomes the lower address register of the next iteration. The erasable memory banks are checked from zero through seven with common erasable (60-1374) being checked after each erasable bank.

D. Future Reassemblies

Future reassemblies of Sunburst will not be protected by cuss if a bank is loaded to the point of not leaving room for the two TC selfs normally preceeding the Bugger word. The 206 version of SELF-CHECK requires the two TC selfs in order for ROPECHK or SHOWSUM to work with the resulting program. (The 258 version of SELF-CHECK does not require the two TC selfs for ROPECHK or SHOWSUM to work.)

BLOCK II AGC SELF-CHECK AND SHOW-BANKSUM

ABSTRACT

This report is in two main sections. The first section contains the operating procedures to be utilized by persons using the SELF-CHECK or SHOW-BANKSUM routines. It also has block diagram flow charts which should help explain how the operating procedures of SELF-CHECK may be used for diagnostic purposes. The procedures for SELF-CHECK are slightly different in BLOCK I and BLOCK II while the procedures for SHOW-BANKSUM are the same.

The second section of this report goes into an explanation of SELF-CHECK and SHOW-BANKSUM. The explanation of SELF-CHECK consists of an explanation of the computer internal selfcheck and an explanation of the check of the DSKY electroluminescents. There is a separate description of each subroutine in SELF-CHECK and SHOW-BANKSUM. There is also a separate flow chart, located in the appendix, for each subroutine. This section should prove helpful to field engineers in locating the cause of malfunctions in the computer.

All numbers in this report are octal unless specifically mentioned otherwise.

The two subroutines that check the multiply and divide arithmetic functions of the computer will be removed from flight ropes. Figure 1 shows that placing a ± 6 or ± 7 in the SMODE register will allow the computer to loop in either the arithmetic multiply or arithmetic divide subroutines if these subroutines are part of SELF-CHECK. Placing a ± 6 or ± 7 in the SMODE register will exercise the internal computer self-check when these two subroutines are removed from SELF-CHECK. Thus, ± 6 , ± 7 , or ± 10 all perform the same function when the arithmetic multiply and arithmetic divide are removed from SELF-CHECK.

by Edwin D. Smally

December 1966

TABLE OF CONTENTS

	<u>Page</u>
PART I. OPERATING PROCEDURES FOR SELF-CHECK AND SHOW-BANKSUM	
CHAPTER	
1 SELF-CHECK OPERATING PROCEDURES	7
Options Available in SELF-CHECK	7
Procedure to Start SELF-CHECK	9
Malfunction Indication	9
Changes (if any) in SELF-CHECK Options When a Malfunction is Detected	11
How to Use the DSKY to Monitor SELF-CHECK	13
2 SHOW-BANKSUM OPERATING PROCEDURES	15
Procedure to Start SHOW-BANKSUM	15
Procedure to Display Next Bank	15
Procedure to Stop SHOW-BANKSUM	15
PART II. EXPLANATION OF SELF-CHECK AND SHOW-BANKSUM	
3 EXPLANATION OF COMPUTER INTERNAL SELF-CHECK	17
<u>Check of Pulses</u>	18
TC+TCF	19
CCSCHK	19
BZMFCHK	19
RESTORE1	19
RESTORE2	20
RESTORE3	20
BZFCHK	20

	<u>Page</u>
DXCH+DIM	20
DAS+INCR	20
MPCHK	21
DVCHK	21
MSUCHK	21
MASKCHK	21
NDX+SU	21
D--SC	21
D--LCHK	21
ADDRCHK	21
RUPTCHK	22
IN-OUT1	22
IN-OUT2	22
IN-OUT3	22
<u>Check of Special and Central Registers</u>	22
COUNTCHK	22
O-UFLOW	23
<u>Check of Erasable Memory</u>	23
ERASCHK	23
CNTRCHK	24
CYCLSHFT	24
<u>Check of Rope Memory</u>	24
ROPECHK	24
<u>Check of Multiply Arithmetic Function</u>	25
MPNMBS	25
<u>Check of Divide Arithmetic Function</u>	25
DV1CHK	26
DV2CHK	26
DV4CHK	26
DV5CHK	26
4 EXPLANATION OF DSKYCHK	27
5 EXPLANATION OF SHOW-BANKSUM	29
APPENDIX	31

PART I

OPERATING PROCEDURES FOR SELF-CHECK AND SHOW-BANKSUM

CHAPTER 1

SELF-CHECK OPERATING PROCEDURES

There are 19 possible options in this BLOCK II version of SELF-CHECK. These options are explained farther on in this report. The first 18 options are used to check the internal operation of the computer (+0 to +10) while the 19th option (+11) checks the electroluminescent displays on the DSKY. It is felt that most people will use the options associated with +10 or -zero since all three of these options perform a complete internal self-check of the computer, however, these three options perform different diagnostic functions when an error is detected. The options associated with +1 to +7 check out various parts of the computer and will be useful for field engineers or other personnel interested in diagnostic testing of the computer.

The normal use of SELF-CHECK is as a backup routine to check the computer continuously when the computer is not busy with other routines. The +10 or -zero options can be used for this purpose.

Options Available in SELF-CHECK

The different options of BLOCK II SELF-CHECK are controlled by putting different numbers in the SMODE register (normally during the SELF-CHECK start procedure); this is the same as BLOCK I. However, it should be noted that the options are not the same in the BLOCK I and BLOCK II computers.

Placing a +0 in the SMODE register forces the computer to go into the backup idle loop where it continuously looks for a new job.

Placing a +NON-ZERO number below octal 12 or -0 number in the SMODE register starts one of the active options of SELF-CHECK. Below is a description of what part (s) of the computer the options check. A block diagram in Figure 1 on the next page shows the options available and indicates the number to put in the SMODE register for the desired option.

- | | |
|-----------|---|
| +1 octal: | checks all pulses possible by internal control of the computer. |
| +2 octal: | checks all the IN-OUT instruction pulses. |
| +3 octal: | checks SC registers and all bit combinations. |

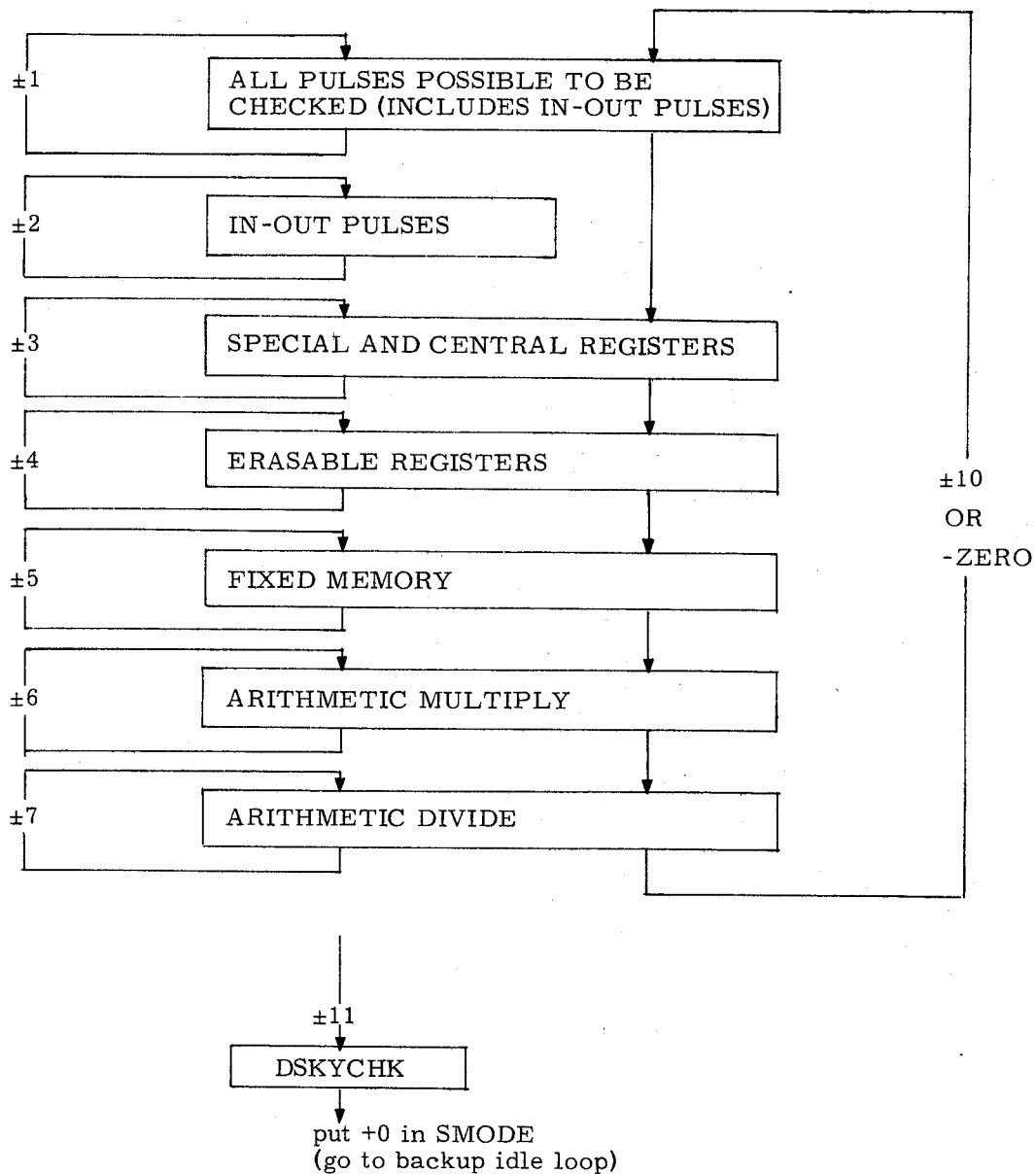

Fig. 1 OPTIONS OF SELF-CHECK

The numbers associated with the options represent the contents of the SMODE register.

The +0 option forces the computer to stay in the backup idle loop, a tight loop which looks for a new job from the EXECUTIVE.

- +4 octal: checks erasable memory.
- +5 octal: checks fixed memory.
- +6 octal: an extensive multiply arithmetic check.
- +7 octal: an extensive divide arithmetic check.
- +10 octal: checks everything in the previous seven options (internal self-check of the computer).
- +11 octal: turns on the electroluminescent displays in the DSKY.
- zero: this option is the same as the +10 options until an error is detected.
- +zero: does not purposely check any part of the computer.

Procedure to Start SELF-CHECK

SELF-CHECK has its own verb-noun combination that should be utilized when starting any of the options from the DSKY (verb 21 and noun 27).

V21N27E (+0 or +NON-ZERO)E

This procedure puts the desired number in the SMODE register depending upon the option desired. The pressing of the second enter (E) button completes the procedure.

Report E-1905 by Alan I. Green is recommended for those not acquainted with the operation of the keyboard and display of the Apollo computer. A description of what the three symbols used stand for is given below:

- V = Verb
- N = Noun
- E = Enter

Malfunction Indication

The block diagram in Figure 2 on page 10 is used as a reference for this discussion. If SELF-CHECK should locate a malfunction the following sequence of events will occur:

- Step 1: The contents of the Q register is put in the SFAIL register. This is the address +1 of where the error occurred.
- Step 2: The ERCOUNT register is incremented by one.
- Step 3: The program alarm light on the DSKY is turned on.
- Step 4: Octal 01102 is put in the FAILREG register.
- Step 5:
 - (a) stop SELF-CHECK (if c(SMODE) is +NON-ZERO).
 - (b) start at beginning again (if c(SMODE) is -NON-ZERO).
 - (c) continue on with SELF-CHECK at the next address after the error (if c(SMODE) is -ZERO).

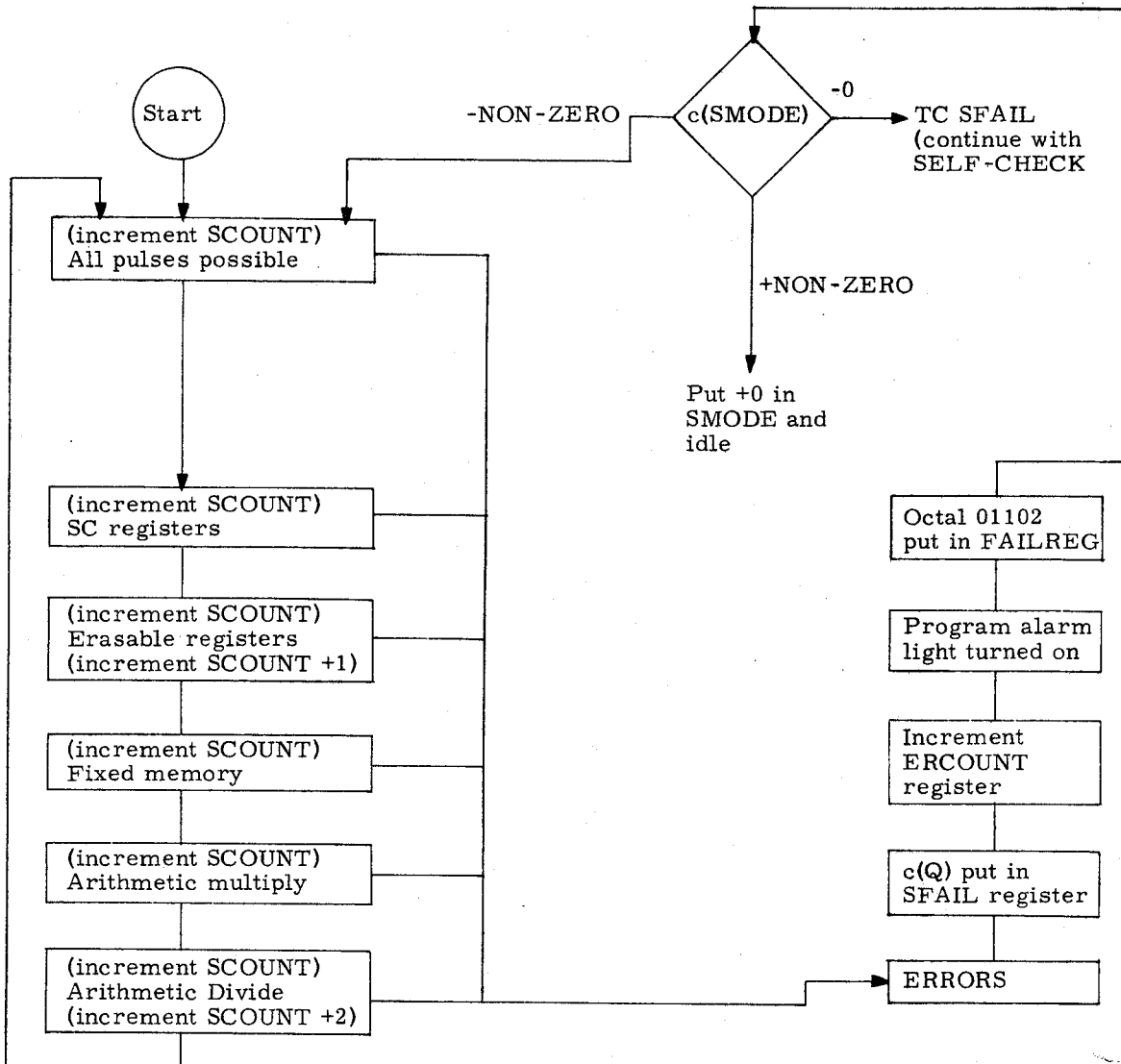

FIG. 2 COUNT REGISTERS AND MALFUNCTION INDICATORS

The above block diagram indicates the flow of SELF-CHECK when ± 10 or $-zero$ is put in the SMODE register.

* SCOUNT +2 is incremented after completion of the fixed memory check when arithmetic multiply and arithmetic divide are removed from SELF-CHECK.

Steps 3 and 4 will be omitted if the contents of the FAILREG register is not +zero. A computer "FRESH START" will set the SMODE, SFAIL, FAILREG, and ERCOUNT registers to +zero. A computer "RESTART" will set the SFAIL register to +zero.

If a second malfunction is located, 41102 is put in the FAILREG register but steps 3 and 4 are omitted. Steps 3 and 4 are omitted from all successive malfunctions until the FAILREG register is made +zero (normally by performing a "FRESH START").

It is possible to leave SELF-CHECK on for a long period and keep track of the number of malfunctions that have occurred by observing the ERCOUNT register. The SFAIL register will contain the error address +1 of the last malfunction.

The "program alarm" light on the DSKY is used by other programs beside SELF-CHECK. Therefore, the FAILREG register (1363) should be observed to verify what type of malfunction occurred should this light come on. An octal number 01102 in this register indicates a SELF-CHECK error. Registers SFAIL (1364) and ERCOUNT (1365) should be observed, and probably recorded, if there has been a SELF-CHECK error because these registers contain the address +1 of where the last error occurred and the total number of errors.

Changes (if any) in SELF-CHECK Options When a Malfunction is Detected

Putting a +11 in the SMODE register illuminates all possible electroluminescent displays on the DSKY. The subroutine puts a +zero in the SMODE register. This routine does not automatically check for a malfunction of the computer. It depends on an observer to watch the DSKY for the proper displays.

No useful function will be performed by putting a number larger than octal 11 in the SMODE register because no SELF-CHECK subroutines have been written for these numbers. If octal 12 or a larger number is put in the SMODE register a subroutine will change the contents of the SMODE to +zero, which forces the computer to go to the backup idle loop.

Figure 3a shows what happens to the option of SELF-CHECK you are in if an error is detected while +1 to +10 is in the SMODE register. First, the malfunction indications previously described are gone through if the number in the SMODE register is either +NON-ZERO. However, the next step depends on the sign of the number in the SMODE register. If the number is plus, the contents of the SMODE register is changed to +zero which forces the computer into a backup idle loop. If the number in the SMODE is negative, the subroutine that is associated with that number is started at the beginning again and the contents of the SMODE register is not changed.

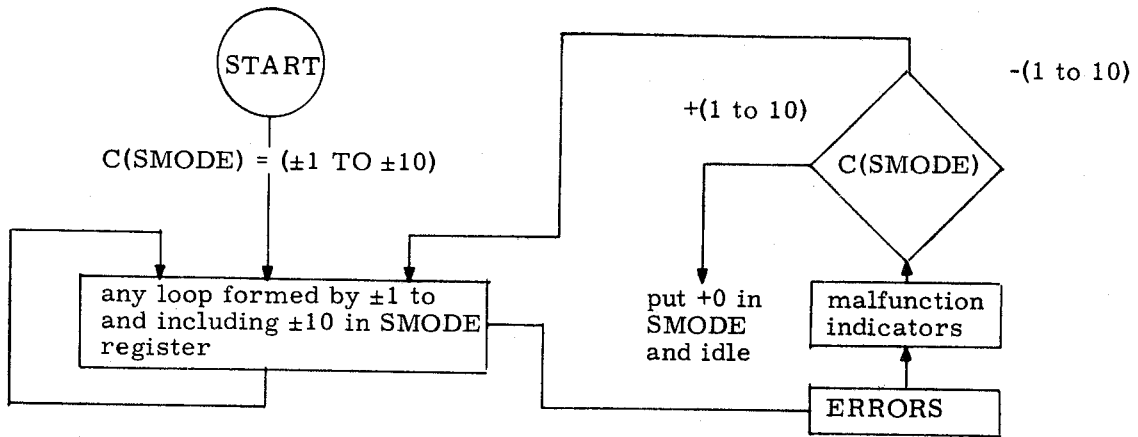

FIG. 3a

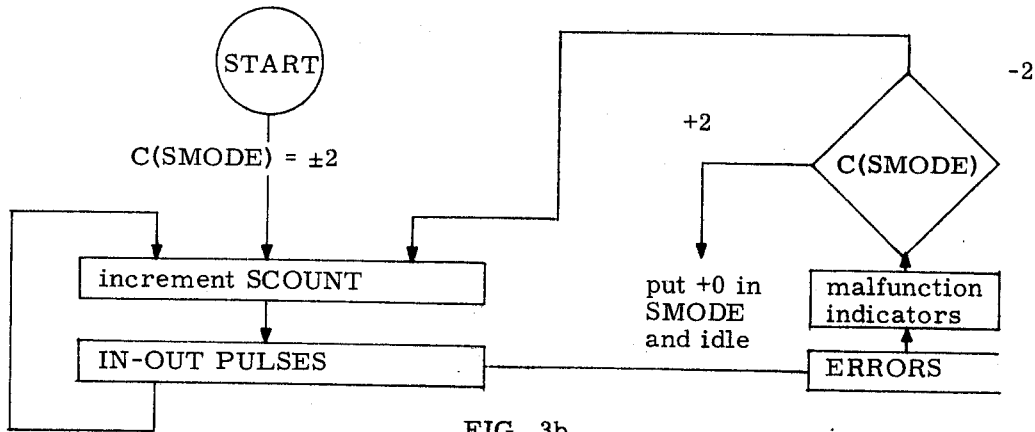

FIG. 3b

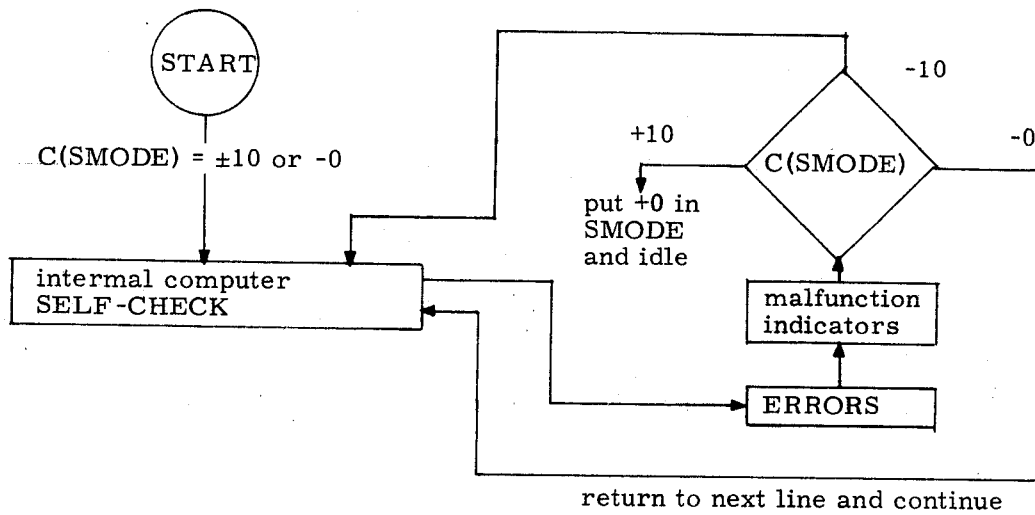

FIG. 3c

Fig. 3 ERROR OPTIONS OF SELF-CHECK

Figure 3b shows what happens when ± 2 is in the SMODE register and an error is detected. The SCOUNT register is incremented at the beginning of each of the subroutines that make up the internal computer selfcheck, even if they are run through consecutively as they are when ± 10 or $-zero$ is in the SMODE register.

Figure 3c shows what happens to the options of SELF-CHECK controlled by ± 10 or $-zero$ being in the SMODE register. The reader should also look at Figure 2 to observe how the ± 1 to ± 7 options are run through consecutively when ± 10 or $-zero$ is in the SMODE register. If an error is detected while ± 10 is in the SMODE register, it is replaced by a $+zero$. If a -10 is in the SMODE register, the internal computer self-check is started at the beginning again. If a $-zero$ is in the SMODE register, the computer goes back to continue checking the internal computer self-check at the nextline from where the error was detected. Of course the malfunction indicators are updated every time an error is detected.

How to Use the DSKY to Monitor SELF-CHECK

The block diagram in Figure 2 shows how the three SCOUNT registers may be utilized to monitor the operation of SELF-CHECK. Register SCOUNT (1366) is incremented at the start of each of the seven minor loops that make up the internal computer self-check. Register SCOUNT +1(1367) is incremented upon the completion of the erasable memory part of the internal computer self-check when ± 4 , ± 10 or -0 is in the SMODE register. Register SCOUNT +2(1370) is incremented upon the completion of the arithmetic divide part of the internal computer self-check when ± 7 , ± 10 , or -0 is in the SMODE register. The incrementing of the SCOUNT +2 register when ± 10 or -0 is in the SMODE register indicates the successful completion of the internal self-check of the computer. If a V15N01E 1366E is performed on the DSKY, the contents of these three count registers will appear in R1, R2, and R3 of the DSKY.

It may be desirable, for information or diagnostic reasons, to set the three SCOUNT registers and the ERCOUNT register to zero before initiating one of the options of SELF-CHECK. If so, these four registers have to be set to zero from the DSKY. The following procedure will accomplish this:

Step 1:	V21N01E	1765E	00000E	(ERCOUNT register)
Step 2:	N15E	00000E		(SCOUNT register)
Step 3:	E	00000E		(SCOUNT +1 register)
Step 4:	E	00000E		(SCOUNT +2 register)

CHAPTER 2

SHOW-BANKSUM OPERATING PROCEDURES

The SHOW-BANKSUM routine shows the sum of the bank in R1 of the DSKY, the bank number in R2 of the DSKY (should be same number as in R1, but can be positive or negative), and the "bugger" word in R3 of the DSKY. The operating procedure consists of three steps: it is important to perform the last step to end this particular job.

Procedure to START SHOW-BANKSUM

This routine has its own Verb (56) so it is very easy to start. The information for bank 00 appears in R1, R2, and R3 of the DSKY immediately after starting SHOW-BANKSUM.*

STARTING PROCEDURE V56E

Procedure to Display Next Bank

The "proceed" verb is utilized to display the sum of the rest of the banks. Each time the proceed verb is entered from the DSKY, the information for the next higher bank appears in R1, R2, and R3 of the DSKY. If another "proceed verb enter" is performed after the last bank in a particular rope has been observed, the information for bank 00 will be displayed again. Continued proceed verb enters will allow you to observe all the banks a second time.

CONTINUE PROCEDURE V33E

Procedure to Stop BANK-SHOWSUM

The operator must punch in the "terminate" verb when he is through with SHOW-BANKSUM. This terminates the SHOW-BANKSUM routine in the EXECUTIVE.

TERMINATE PROCEDURE V34E

* Starting SHOW-BANKSUM puts +0 in the SMODE register. This forces SELF-CHECK to go into the backup idle loop.

PART II

EXPLANATION OF SELF-CHECK AND SHOW-BANKSUM

CHAPTER 3

EXPLANATION OF COMPUTER INTERNAL SELF-CHECK

SELF-CHECK has been written so it is a check of the computer by the computer. The 19 options described in the "Operating Procedures" part of this report may be utilized for diagnostic purposes should the computer develop a malfunction. Eighteen options are related to the internal operation of the computer; the other option lights up DSKY electroluminescents. The fact that it is possible to successfully change the options of SELF-CHECK assures the basic operation of the EXECUTIVE and much of the DSKY.

There are seven major sections in this version of SELF-CHECK; a minor section (IN-OUT pulses) is also a part of one of the major sections (all pulses possible). The first major section exercises almost all of the control pulses used by the computer. The second major section checks the special and central registers. Erasable memory is checked thirdly. The fourth section checks for the correct contents of the rope and checks the computer circuitry associated with fixed rope memory. The fifth and sixth sections check the arithmetic operations of the multiply and divide instructions. The electroluminescent displays on the DSKY are checked in the seventh section.

Three of the options available in SELF-CHECK allow the computer to consecutively execute the first six major sections of SELF-CHECK. These six sections are considered the internal selfcheck of the computer. Following is a list containing all of the subroutines of these six sections in chronological order as they would be performed when performing the internal selfcheck.

TC+TCF
CCSCHK
BZMFCHK
RESTORE1
RESTORE2
RESTORE3
BZFCHK
DXCH+DIM
DAS+INCR
MPCHK

checks almost all pulses.
35 to 45 milliseconds.

The only non-programmable instruction that is checked is PINC, which is checked in the RUPTCHK subroutine. The fact that TIME3 interrupts 2 1/2 milliseconds after TIME4 assures the proper functioning of all the pulses in this instruction. It is not possible to check the pulses in the other non-programmable instructions.

No particular effort has been made to check the pulses associated with the S, Z, and SQ registers. Some of these pulses are used in every memory cycle and the fact that SELF-CHECK is successfully completed assures the existence of these pulses.

A short description of the pulses checked by each subroutine in the pulses section of this report will now be given:

- TC+TCF This subroutine checks all of the pulses of the TC and TCF instructions except the ability to TC to erasable memory. A CS fixed memory instruction is used for the first time and is checked by the next subroutine.
- CCSCHK The main purpose of this subroutine is to make sure the CCS instruction performs the four required branches correctly and that c(A) is correct after each branch. It was necessary to perform a fifth CCS to make sure the CI pulse forced the result of a +1 to be +0. All of the CCS pulses are checked except RB-WG.
- This subroutine also checks pulses associated with CS fixed, erasable, and special and central memory. Also those associated with a TS to erasable memory.
- BZMFCHK All of the pulses used by the BZMF instruction are checked by the BZMFCHK subroutine. Also those pulses used by CA fixed memory.
- The fact the BZMF instruction should jump when the $c(A) \leq 0$ and that it should not jump when $c(A) = +NON-ZERO$ is checked. Also that it does not jump when c(A) is overflow with +0 (01-00000).
- RESTORE1 This subroutine checks the ability of the NDX, CCS, AD, MSU, SU, CA, and MASK instructions to read the original contents back into erasable memory. The normal operation of these instructions are not of primary importance.

The NDX erasable, CA erasable, and MASK erasable instructions are used and checked for the first time.

The fact that the MASK, MP, and DV instructions do not edit is also checked.

- RESTORE2 This subroutine checks the ability of the extended NDX, DCA, and DCS instructions to read the original contents back into erasable memory. The normal operation of these instructions are not of primary importance.
- The pulses used by the XCH erasable, extended NDX erasable, extended NDX fixed memory, DCS erasable, CA special and central, and the DCA erasable instructions are checked.
- RESTORE3 The ability to restore instructions back into erasable memory is checked by this subroutine.
- BZFCHK All of the pulses used by the BZF instruction are checked by the BZFCHK subroutine. The fact that the BZF instruction should jump when the $c(A) = \pm 0$ and should not jump when $c(A) \neq \pm 0$ is checked. It is also made sure that the BZF instruction will not jump with overflow (01-0000) and underflow (10-377777) in the A register.
- DXCH+DIM DXCH+DIM checks all of the pulses used by the DXCH and the DIM instructions. It also checks the pulses used by the TS with overflow, TS special and central, CA special and central, and AD erasable instructions.
- DAS+INCR This subroutine checks all of the pulses in the DAS and INCR instructions. It also checks the pulses used by the DCA fixed memory, DCS fixed memory, LXCH special and central, and XCH special and central memory instructions.
- The pulses in the AD instruction are also checked thoroughly for the first time. The AD instruction has been used before but this is the first time the result of the addition has been checked.

MPCHK The MPCHK subroutine checks all of the pulses used by the MP, AUG, and ADS instructions. The AUG and ADS instructions are utilized in the process of checking the four sign combinations possible in multiply.

DVCHK All of the pulses of the DV and QXCH instructions are checked by this subroutine as well as the pulses used by the TS with underflow instruction. Six divides are used to thoroughly check out all the sign combinations and other features of this instruction.

MSUCHK This subroutine checks all of the pulses of the MSU instruction except the RB-WG pulses, which are checked by the RESTORE1 subroutine.

MASKCHK MASKCHK checks the pulses in the MASK that have not previously been checked.

NDX+SU This subroutine finishes checking the pulses in both the index instructions. It also checks all of the pulses in the SU instruction except RB-WG, which are checked in the RESTORE1 subroutine.

D--SC The D--SC subroutine checks that DCS, DXCH, and DCA can be performed on special and central registers. A DXCH and DCS is performed on the L register because the order sequence of pulses can be checked more thoroughly by using this register.

D--LCHK This subroutine was written to check that the overflow bit disappeared when a word went into and out of the L register and to make sure that the Q register was capable of holding 16 bits.

ADDRCHK ADDRCHK makes sure the overflow, underflow, end-around-carry features, and other features of the adder are functioning correctly. It also makes sure that the ADS special and central instruction is working satisfactorily when the result of the addition is overflow.

- RUPTCHK The main purpose of this subroutine is to make sure that an overflow-underflow condition in the A register will hold off an interrupt. It also checks that INHINT will also hold off an interrupt and that a waiting interrupt will interrupt immediately after the RESUME instruction. The basic operation of TIME3, TIME4, and the WAITLIST are also checked since they are all used by this subroutine.
- IN-OUT1 Checks all pulses of the WRITE and READ instructions.
- IN-OUT2 Checks all pulses of the ROR and WOR instructions.
- IN-OUT3 Checks all pulses of the RAND, WAND, and RXOR instructions.

Check of Special and Central Registers

This section of SELF-CHECK makes sure the A, B, C, G, and Q registers and the output of the adder have all 16 decimal bit combinations pass through them at least once. All 15 decimal bit combinations are put into and called out of the L register and erasable memory; thus the parity bit is generated and checked for each 15 bit combination. It is not possible to guarantee the parity register is working correctly if words come out of erasable memory correctly. However this part of SELF-CHECK will indicate an error if any bits are dropped or picked up. Therefore, if the parity register does not catch bits being dropped or picked up, this part of SELF-CHECK will indicate a malfunction.

Following is a short description of the subroutines in this part of SELF-CHECK:

- COUNTCHK Effectively counts down a 15 decimal bit number by one until zero is reached and checks that each successive number is actually one less than the number preceding it. Actually bit 15 is a sign bit so the countdown alternates between plus and minus numbers. In the process of counting down the 15 decimal bit number all the bit combinations are generated by the adder and are written in and out of the A, B, C, L, Q, and G registers as well as erasable memory. Also the parity bit is generated and checked internally by the computer for all 15 bit combinations.

O-UFLOW Checks that all overflow and underflow bit combinations are generated by the adder and are written into and out of A, B, C, and Q registers. The procedure used is to count down, by one, from maximum positive overflow and negative underflow conditions until the overflow-underflow condition does not exist. Again there is a check that each successive number is one less than the preceding number.

Check of Erasable Memory

This part of SELF-CHECK makes sure that it is possible to read a "1" and a "0" into and out of each bit position of erasable memory with the following exceptions. Registers 1377, 1376, and 1375 are not specifically checked in this part of SELF-CHECK because they have previously been thoroughly checked while checking the special and central registers. These three registers are required for storage while checking the rest of erasable memory. The special erasable registers from 61 down through 10 are only addressed to see if a parity error occurs. Finally the cycle and shift registers are checked by putting a combination of alternate zeros and ones in these registers and making sure the correct operation is performed.

Following is a short description of the subroutines in this part of SELF-CHECK:

ERASCHK The non-special erasable registers are checked for correct addressing and content by placing their own address in two successive registers and making sure there is a difference of -1 when the contents of the lower address register is added to the complement of the higher address register; if it is not, this subroutine performs a TC to the ERRORS subroutine. The contents of the two registers are complemented and the complement of the lower register added to the contents of the higher register; the result is checked for -1. The previous contents of the erasable registers are preserved and replaced after the registers have been checked. The higher address register of the previous iteration becomes the lower address register of the present iteration. The erasable memory banks are checked from zero through seven with common erasable (60-1374) being checked after each erasable bank.

CNTRCHK The CS instruction is performed on all erasable registers from octal 60 through octal 10. These include all counters and other special erasable registers. It is not feasible to put their own address in these registers and check their contents because of their special use.

CYCLSHFT The octal number 25252 is placed in the two cycle registers, the shift right register, and the EDOP register. The contents of these registers are then twice checked for correct contents.

Check of Rope Memory

The routine for checking the correct contents of a rope is called ROPECHK. Its purpose is twofold. First it is a check on the computer. It makes sure all current drivers, sense amplifiers, and associated circuitry used in connection with the fixed memory are operating properly. Secondly it is a check on the rope itself. It makes sure none of the sense or inhibit lines have become shorted or opened. (essentially guarantees contents of rope is correct and can be read correctly by the computer).

The sum of each bank should be the same as its bank number in the low order bits of the computer. A special word, which is called a "bugger" word, is added to the normal sum of the bank as the last word to be added. This bugger word forces the sum of the bank to be plus or minus the Bank Number. As an example, the sum of bank 33 octal may be 00033 or 77744.

Two TC SELF words indicate the end of the summing process for each bank. The "bugger" word immediately follows the second TC SELF word. Of course all addresses in a bank up to and including the bugger word have to contain words of good parity.

Following is a short description of the ROPECHK subroutine:

ROPECHK Each bank in the rope is summed separately; from the lowest address to the highest address used in that bank. The contents of a higher address is added to the sum of the previous addresses. If this creates an overflow condition a +1 is added to the new sum; a -1 is added to the new sum if an underflow condition is created. The sum of each bank should be plus or minus its own bank number. If the sum of the bank is its bank number the subroutine proceeds on to checking the next bank. If the sum of the bank is not

its bank number SELF-CHECK goes to the error routine.
The banks are checked in ascending order.

Check of Multiply Arithmetic Function

There are four multiply loops in the multiply subroutine. The two main purposes of this subroutine are to form all the different combinations of adds possible in the multiply instruction (1 to 14) and to change the value of the word to be added from minimum to maximum for each combination of add. The total time of the multiply routine takes approximately 20 seconds.

It is felt that the multiply and divide subroutines are a good arithmetic check of the computer. Therefore the long activity time of these subroutines may be utilized to check normal operation of the computer in conjunction with asynchronous and synchronous interface signals. The correct result of each multiply and each divide is verified before proceeding on. The procedure gone through if an error is found is described in the "operating procedures" section of this report.

A description of the multiply subroutine is below:

MPNMBRS The first multiply loop multiplies 37777 by (37777 through 00001). The contents of the A register counts down while the contents of the L register counts up. There is a check after each multiplication that these two registers add up to 37777. The second multiply loop multiplies 77776 by (37777 through 00001). There is a check in this loop that the c (A) is minus zero and the c (L) counts down by minus one after each multiplication. The third loop interchanges the multiplier and the multiplicand of the first loop. The contents of the A and L registers should be the same as in the first loop. The fourth loop interchanges the multiplier and multiplicand of the second loop. The contents of the A and L registers should be the same as the second loop.

Check of Divide Arithmetic Function

The four divide subroutines form different combinations of subtractions while varying the value of the word to be subtracted. It takes approximately 0.01 second to go through all the four divide subroutines. However SELF-CHECK keeps the computer in the divide subroutines for approximately 20 seconds.

Following is a description of the divide subroutines:

- DV1CHK Divides $\pm/17777/\pm/37777/$ by $\pm/20000/$. The contents of the A register and L register have opposite signs before the division. The quotient is $\pm/37774/$; the sign depends on the sign of c (A) and the sign of the divisor. The remainder is ± 1 depending upon the sign of the contents of the A register before the division.
- DV2CHK Divides $+17777+37777$ by $+20000$. The quotient is $+37777$ with $+17777$ the remainder.
- DV4CHK Divides $+37776+0$ by $+37776$. The quotient is $+37777$ with a remainder of $+37776$.
- DV5CHK Divides $\pm 0 \pm 0$ by ± 0 . The contents of the A register and L register have opposite signs before each division. The quotient will be $\pm/37777/$; the sign depends on the sign of c (L) and the sign of the divisor. The remainder is ± 0 ; the sign depends on the sign of the L register before the division. This is not a useful division but it does help to make sure the computer is operating correctly.

CHAPTER 4

EXPLANATION OF DSKYCHK

The purpose of DSKYCHK is to light up all the DSKY electroluminescent elements. It puts a +0 in the SMODE register at the beginning of the routine, which forces the computer internal selfcheck to sleep. This is the only routine in SELF-CHECK that does not have to be terminated. It runs to completion once and then the computer falls into the backup idle loop. The routine has to be entered as one of the SELF-CHECK options every time it is to be exercised.

Each electroluminescent display lasts for 5.12 seconds to allow time to observe all the elements in the display. The sequence of the displays is described next:

DSKYCHK First the digit "9" is displayed in the R1, R2, R3, Verb, Noun, and PROG positions of the DSKY. The digits 8 through 0 are then each displayed in all the possible displays on the DSKY. The next display leaves all zeros in the DSKY and turns on the "computer activity" light and the "verb" flash and the "noun" flash. The last display has only the "computer activity" light on. Finally the DSKY is left completely blank.

CHAPTER 5

EXPLANATION OF SHOW-BANKSUM

SHOW-BANKSUM consists of a routine called SHOWSUM. This routine essentially does the same thing that the routine ROPECHK does; that is, add up the sum of separate banks in the rope. After this the similarity ends. ROPECHK makes sure the sum of the bank is plus or minus its own bank number while SHOWSUM displays the sum of the bank in R1 of the DSKY irrespective of what the sum may be. SHOWSUM also displays the bank number and the bugger word in R2 and R3 of the DSKY at the same time. The sum of the bank and bank number in R1 and R2 are shown as the least significant bit instead of bits 11 - 15 (the actual bank bits in the computer). Again it is worthwhile mentioning that the sum of a bank may be plus or minus its bank number. This is, bank 5 may be 00005 or 77772.

Undoubtedly the greatest use of this routine will be in restoring the confidence of personnel in the computer and in verifying that the correct rope modules for a particular mission are actually the ones in the computer package. Following is a short description of the SHOWSUM subroutine:

SHOWSUM Each bank in the rope is summed separately; from the lowest address to the highest address used in that bank. The contents of a higher address are added to the sum of the previous addresses. If this creates an overflow condition a +1 is added to the new sum; a -1 is added to the new sum if an underflow condition is created. The sum of each bank should be plus or minus its own bank number. The sum of the bank is displayed in R1 of the DSKY. The bank number (actual bank number used to sum the bank shifted 5 places left) is displayed in R2 and the bugger word is displayed in R3. Entering a proceed verb (33) from the DSKY will display the same information for the next higher bank. Entering a terminate verb (34) from the DSKY will end the SHOWSUM routine.

APPENDIX

The flow charts in this appendix use both AGC instructions and word descriptions to explain the subroutines. The purpose was to use word descriptions most of the time and utilize instructions only where they were necessary to make the overall picture clear.

Some explanation of symbols:

b(X) means before contents of X register

c(X) means contents of X register

SKEEP1 through SKEEP7 are erasable registers.

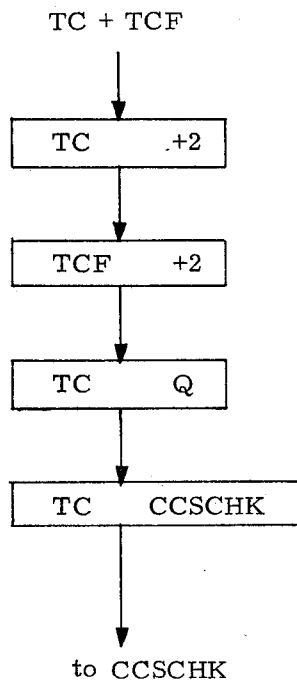

CCSCHK

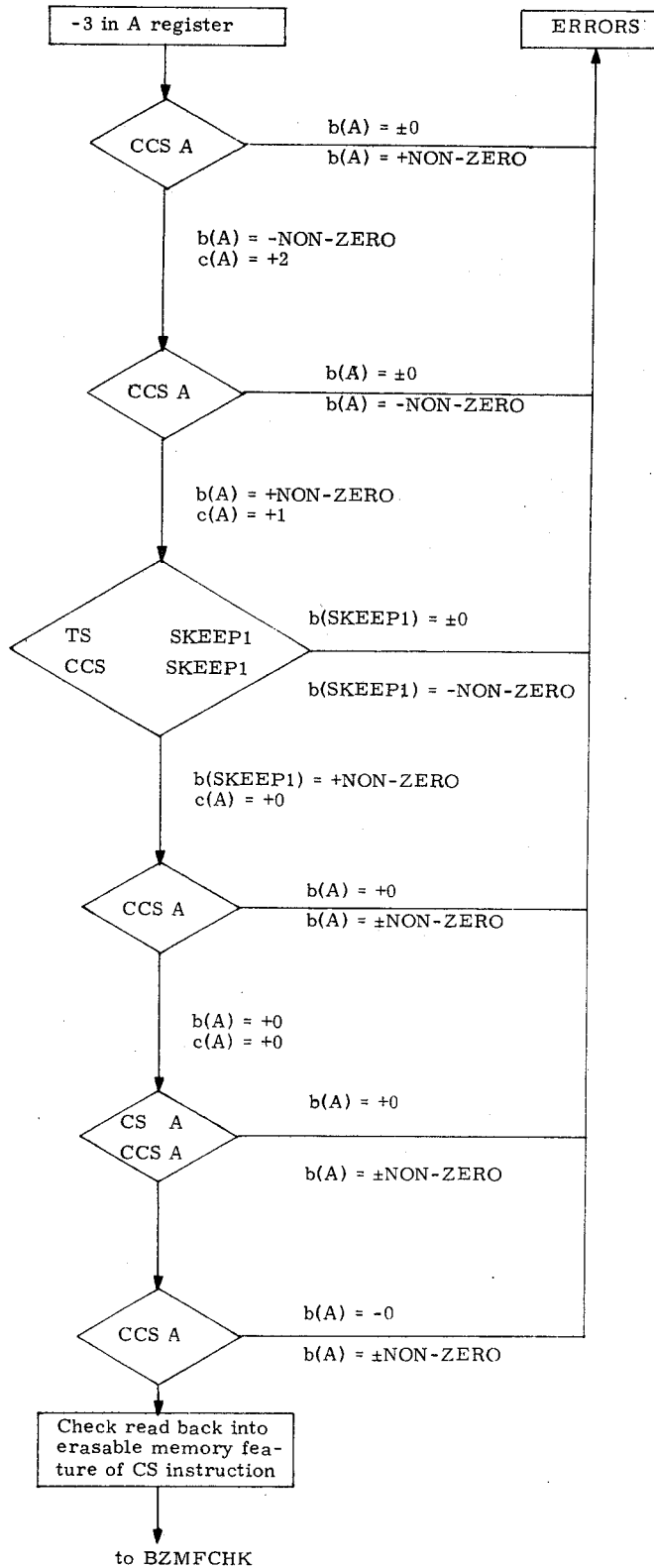

BZMFCHK

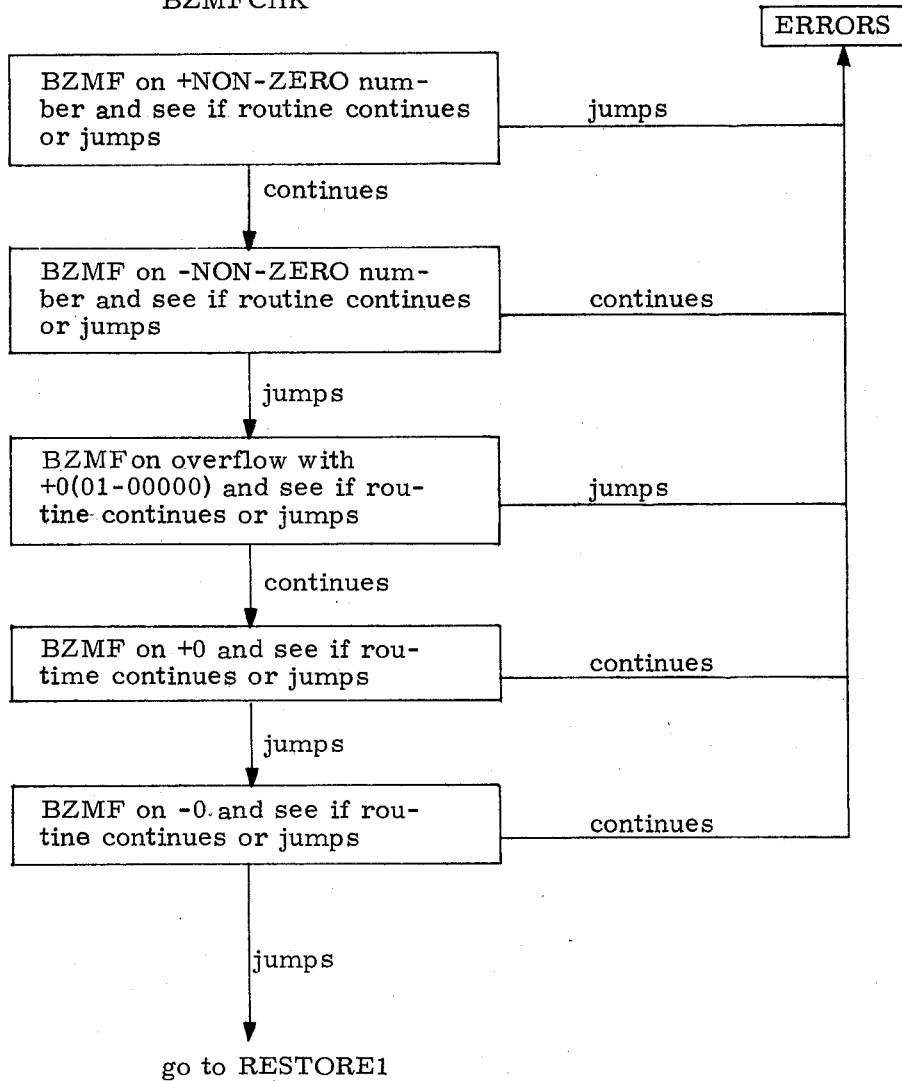

RESTORE1

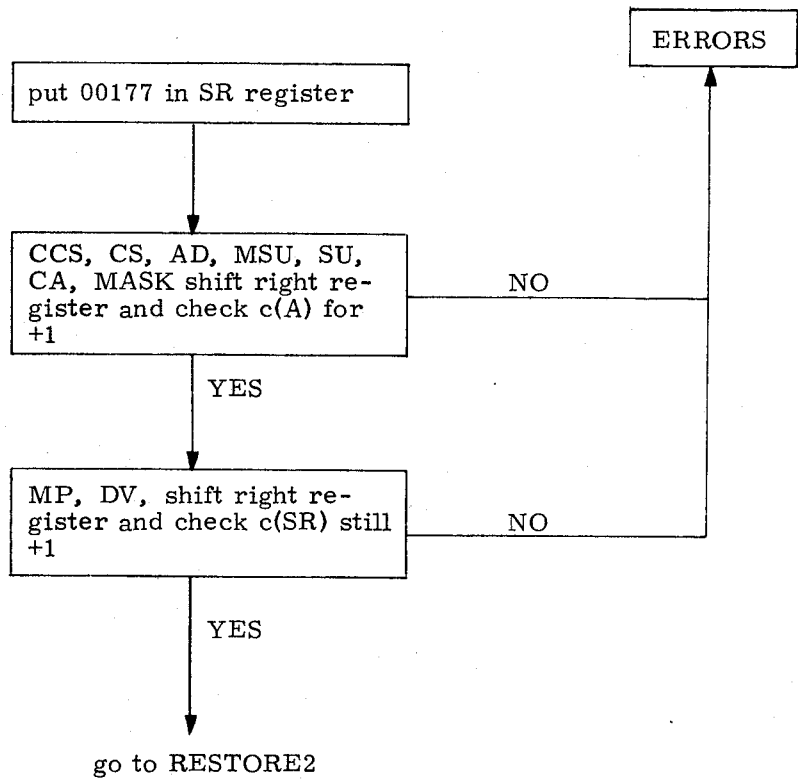

RESTORE2

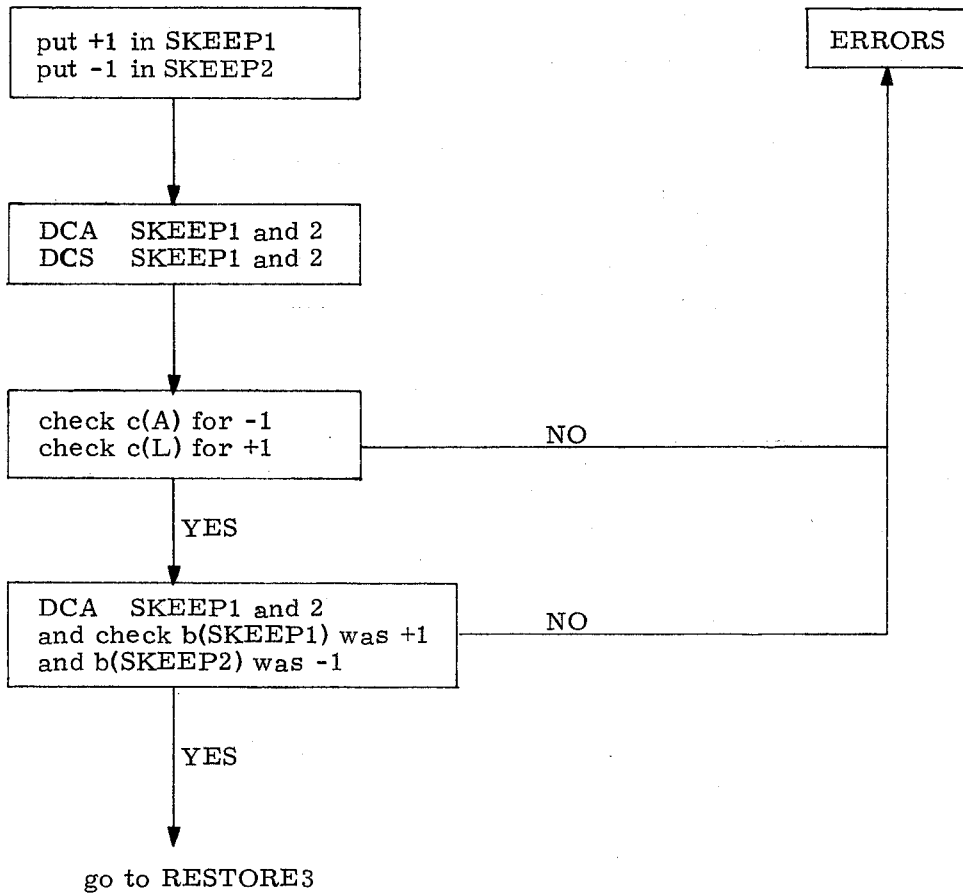

RESTORE3

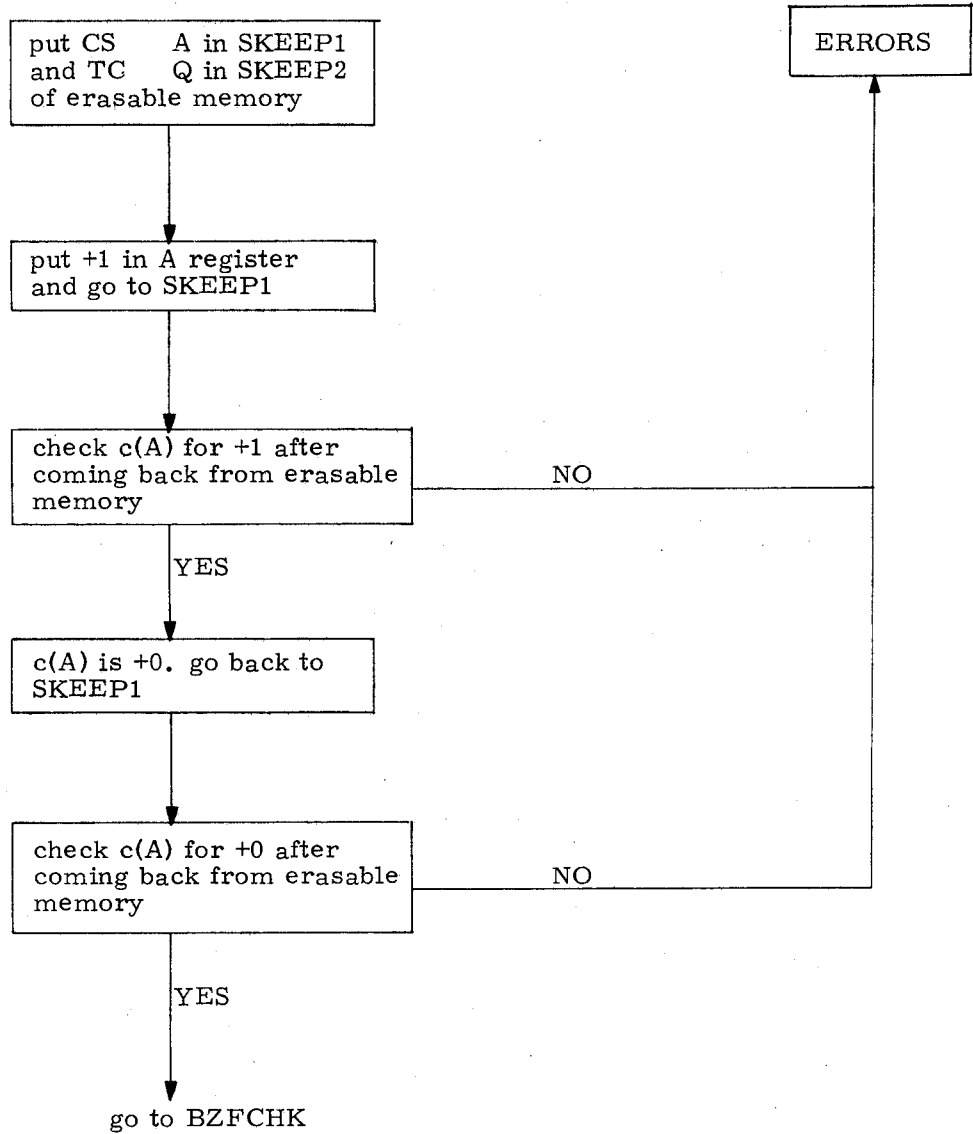

BZFCHK

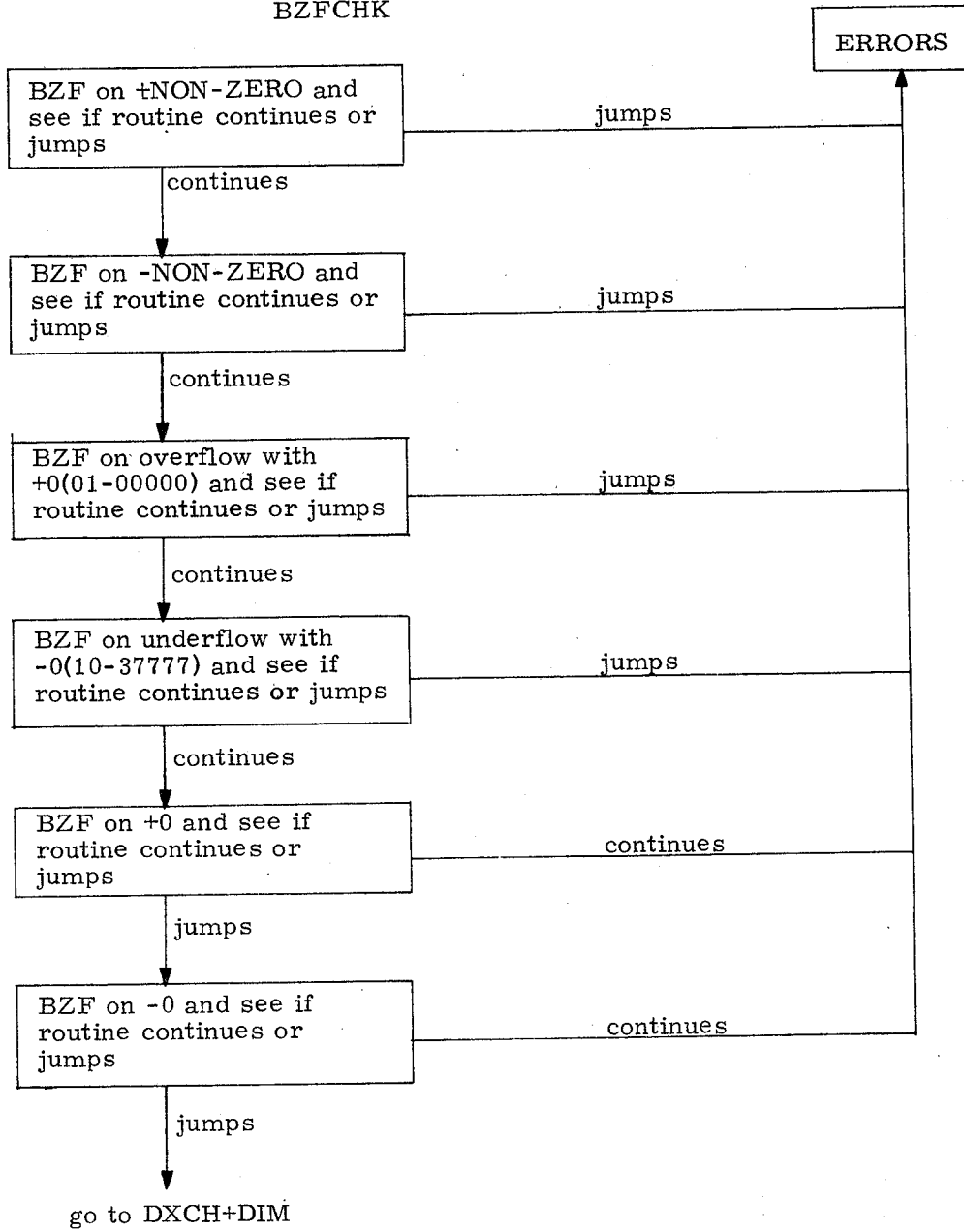

DXCH+DIM

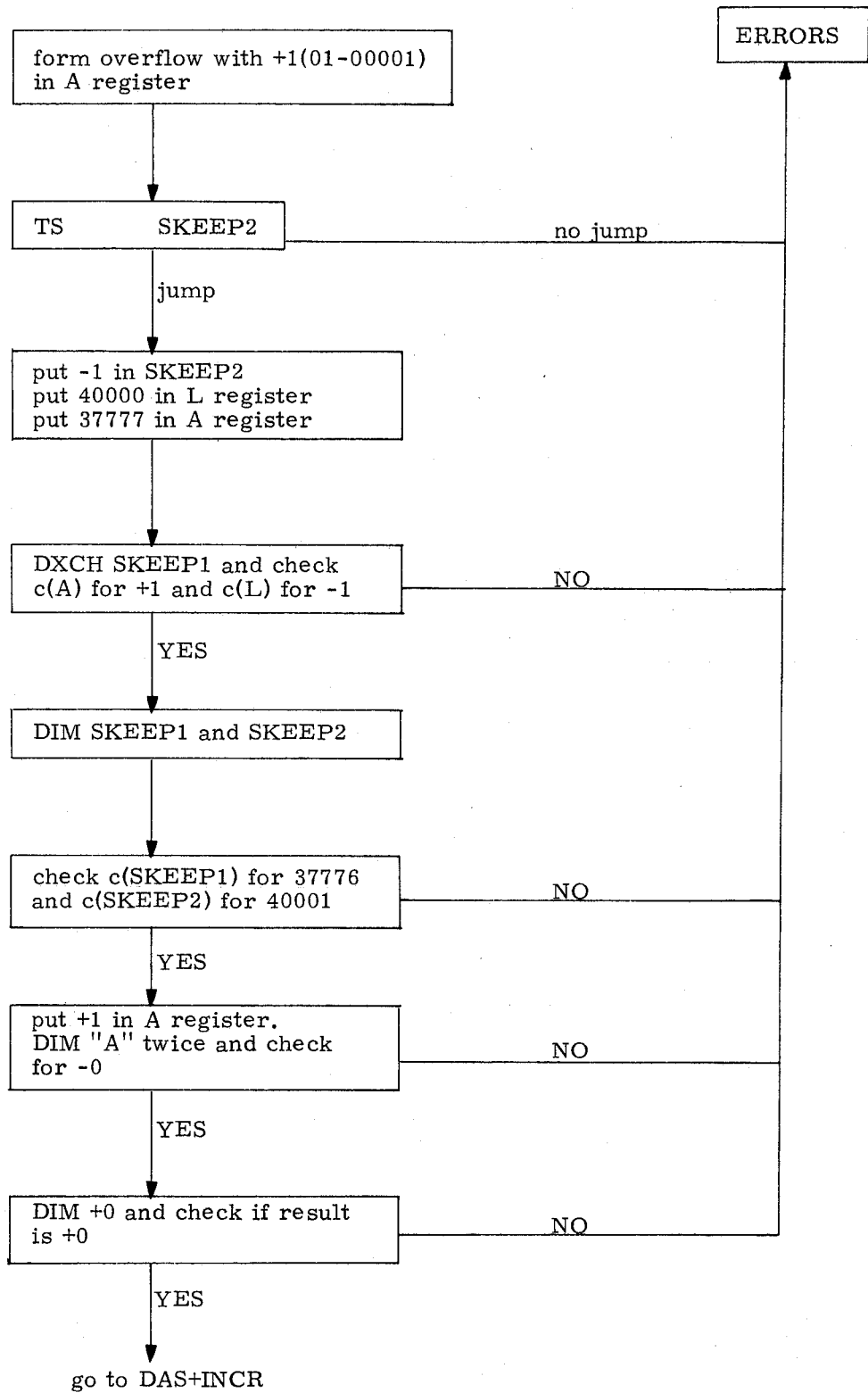

D--LCHK

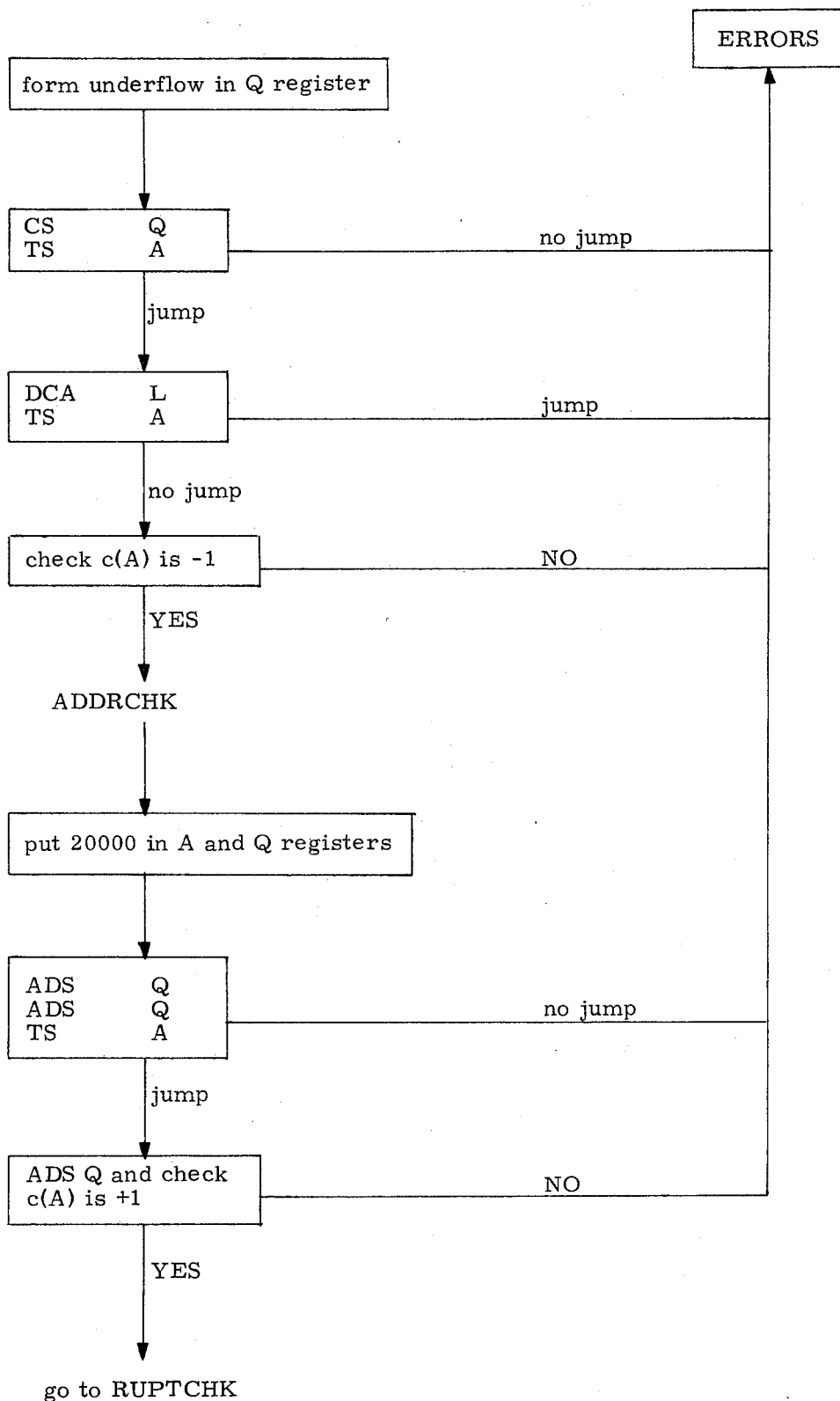

DAS+INCR

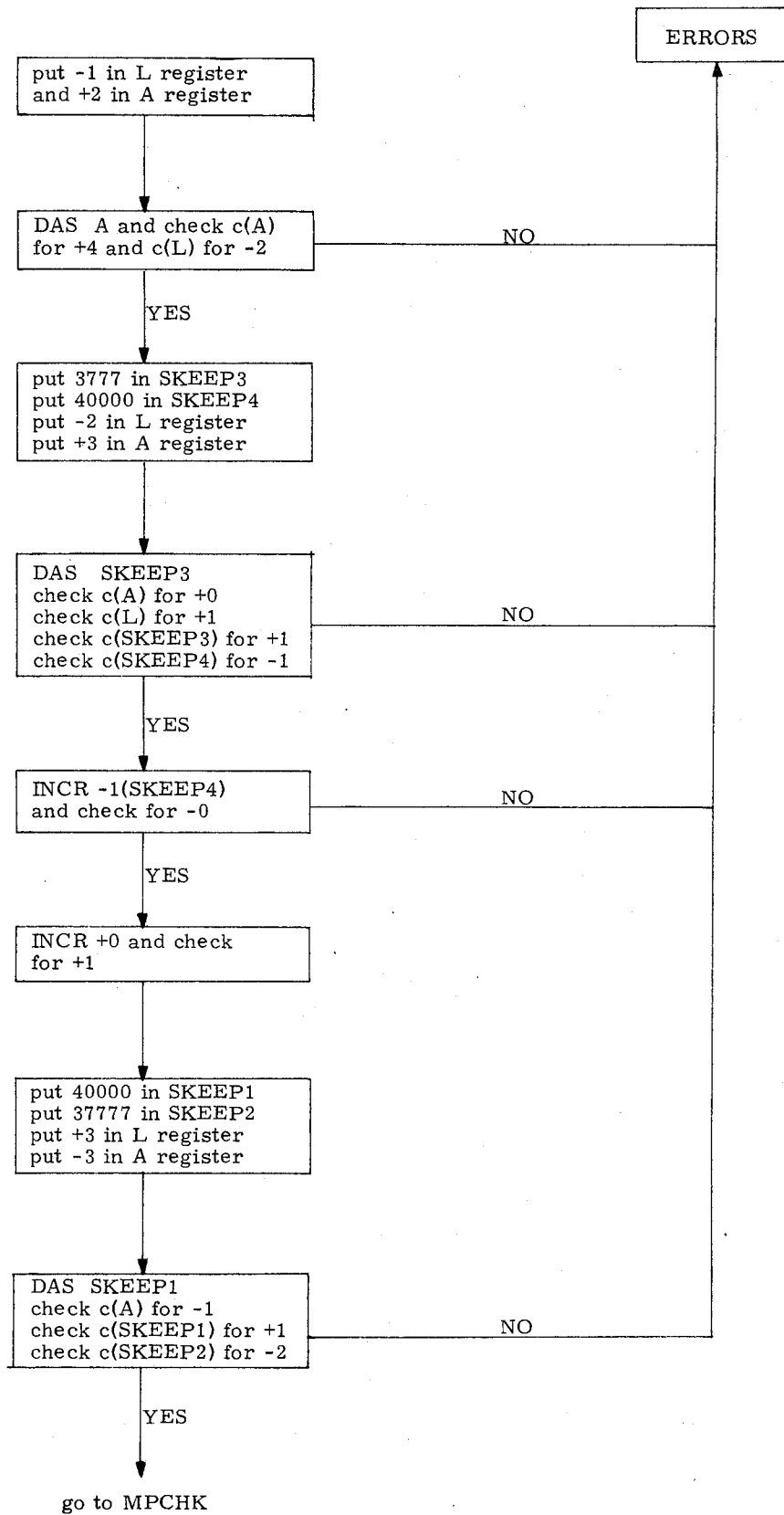

MPCHK

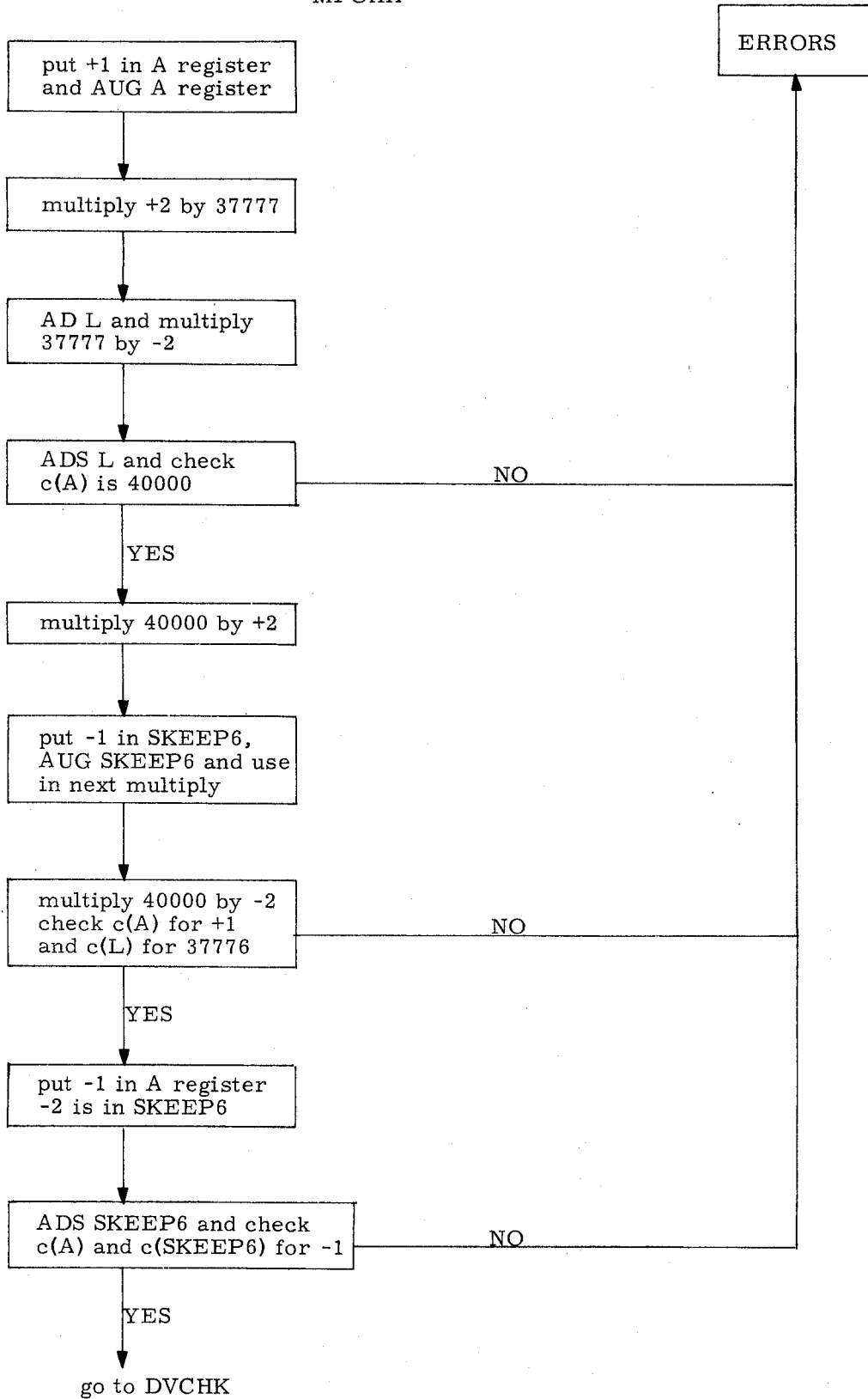

DVCHK

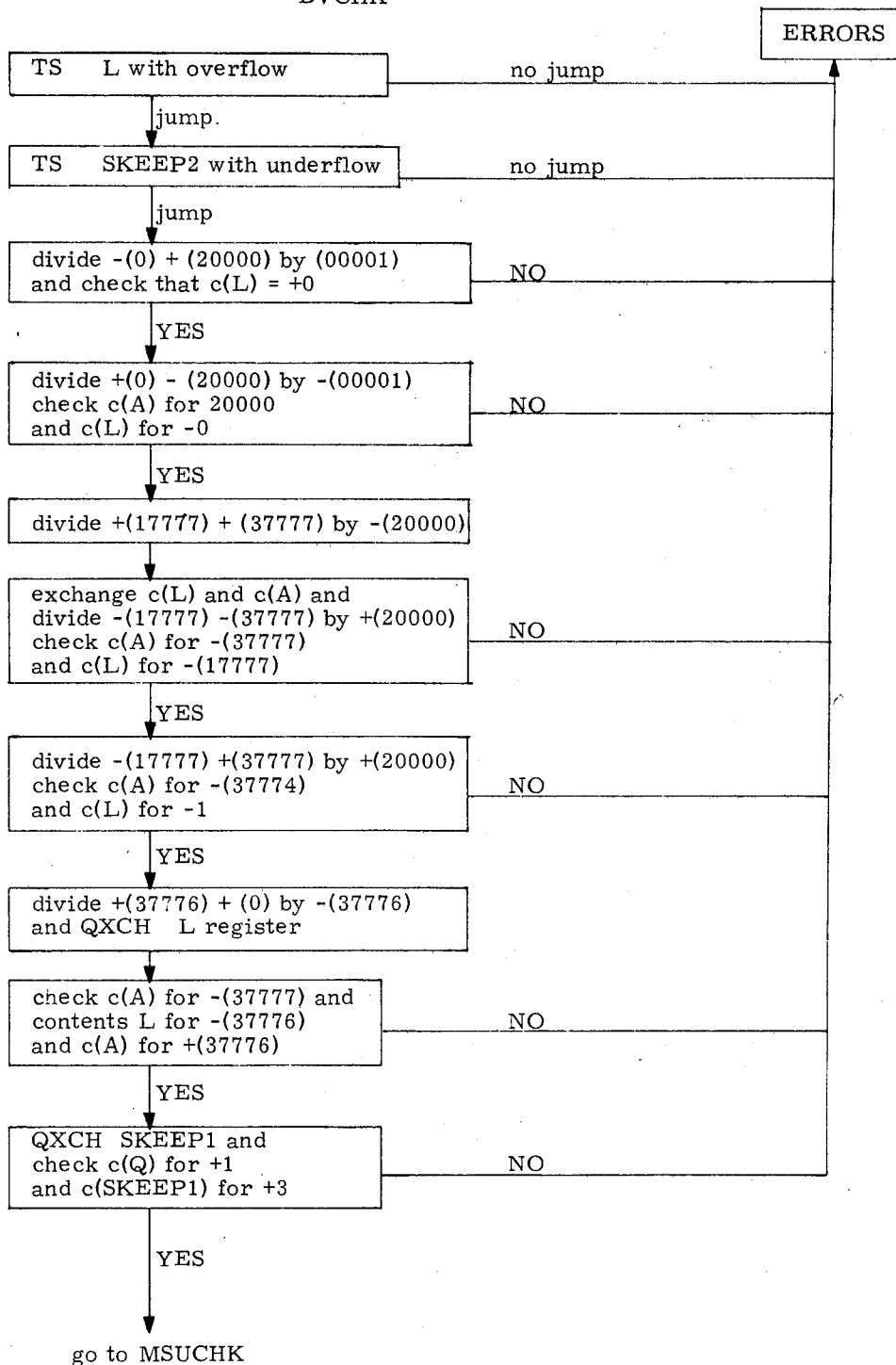

MSUCHK

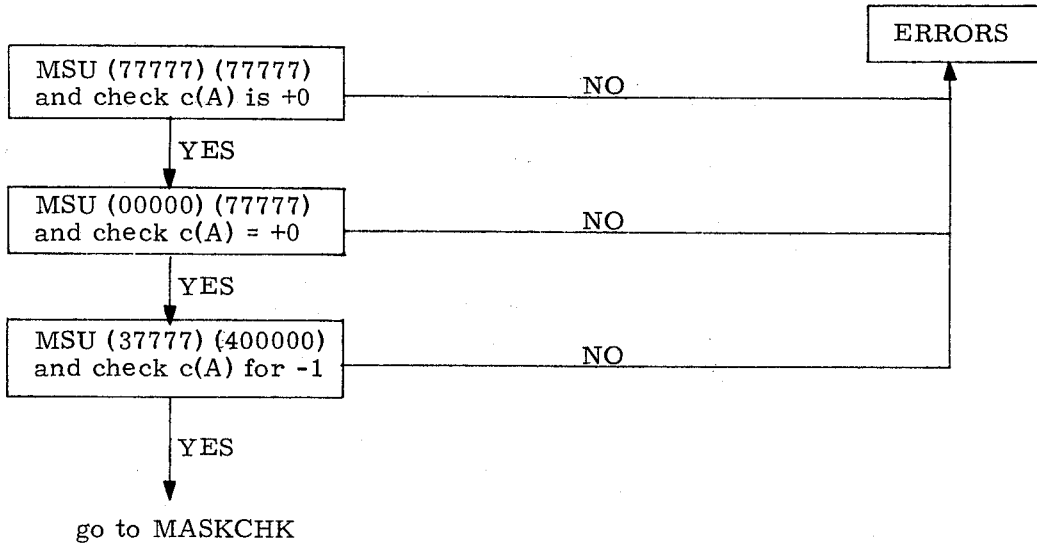

MASKCHK

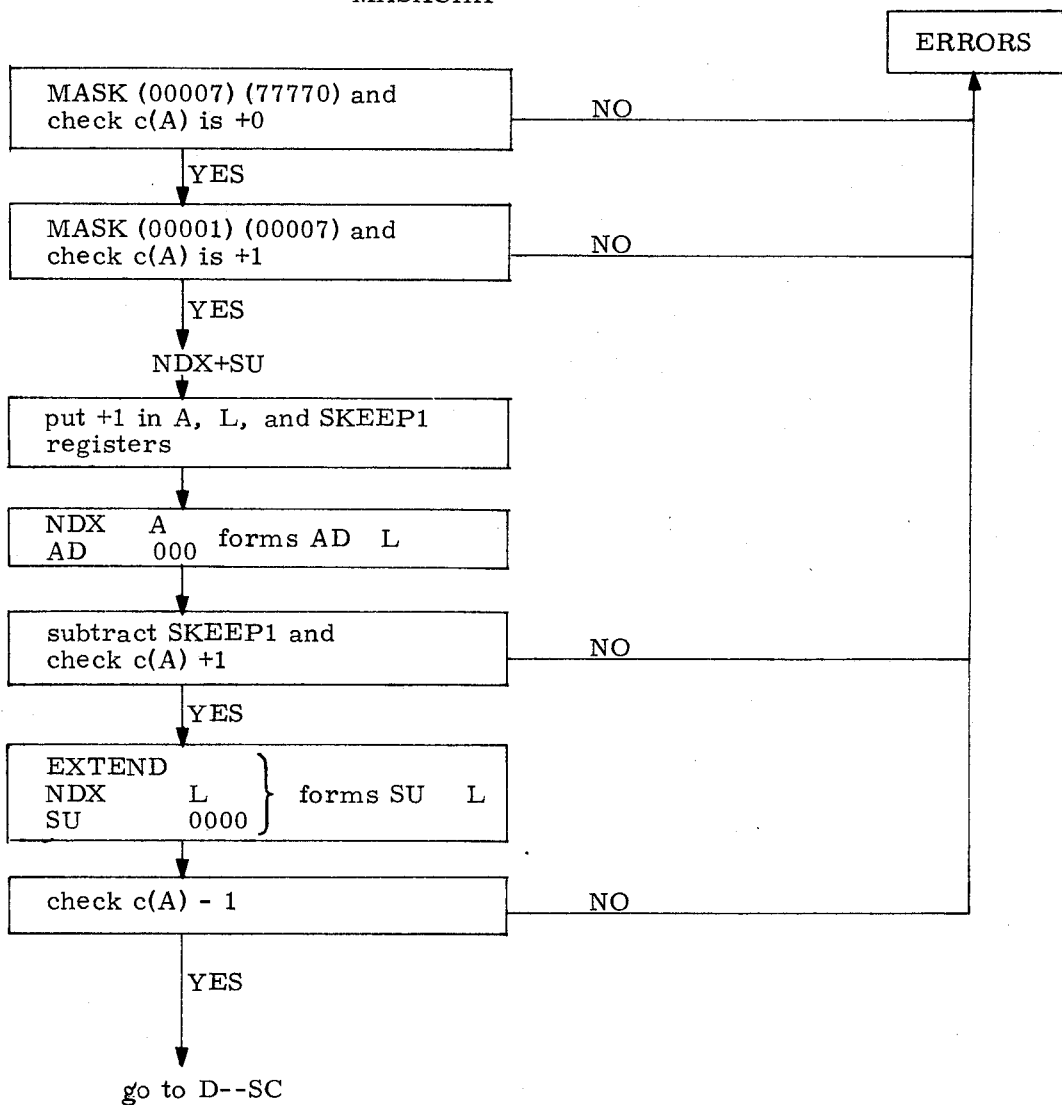

D--SC

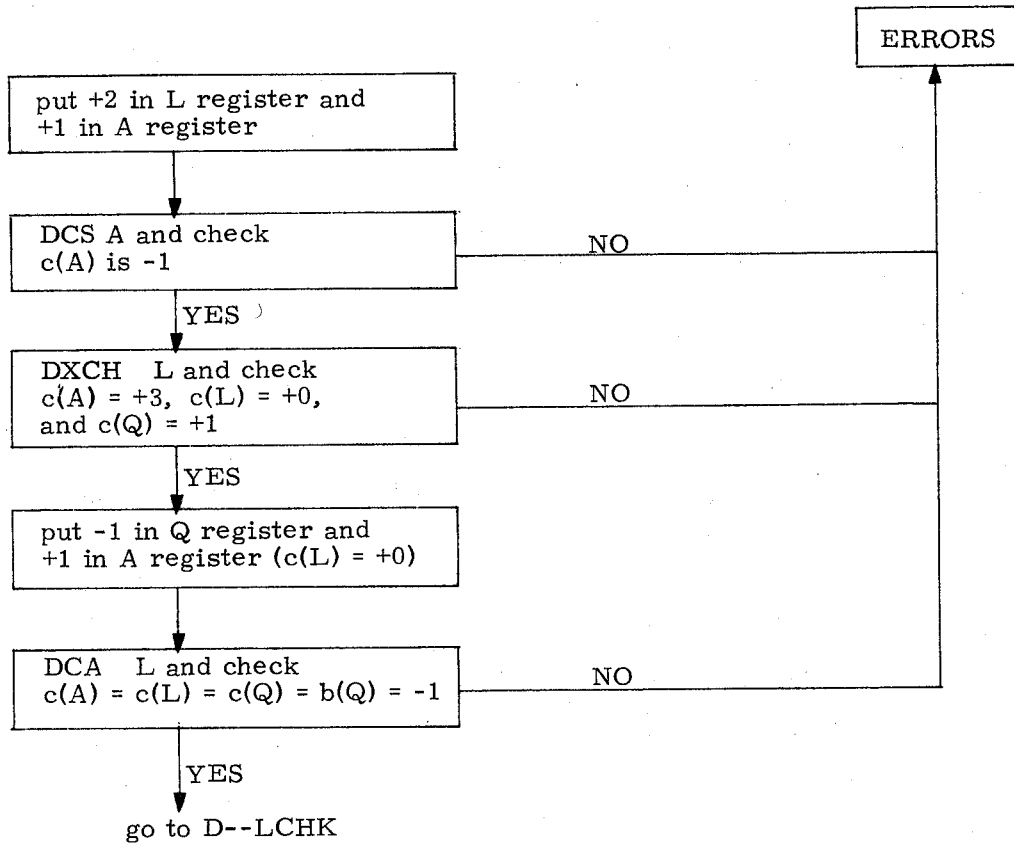

D--LCHK

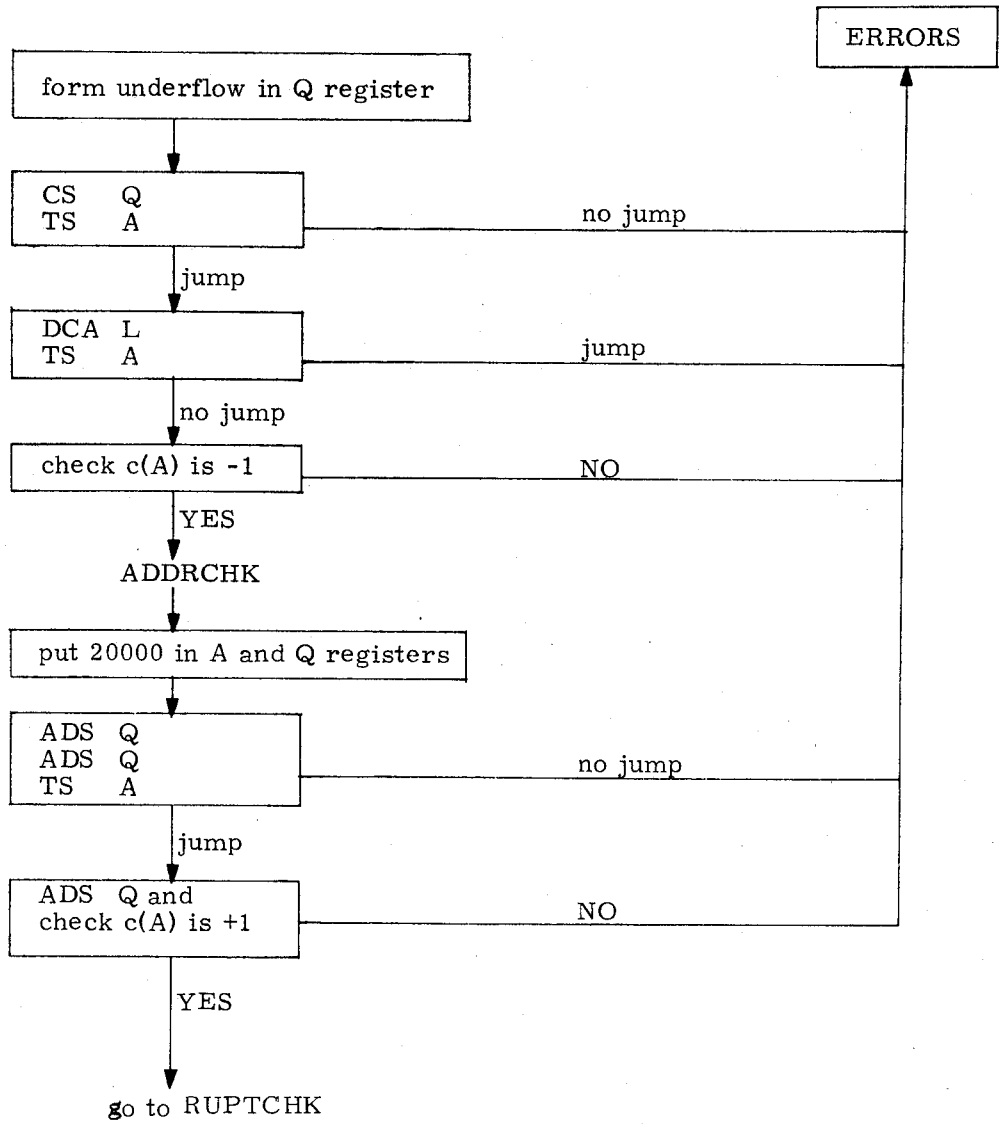

RUPTCHK

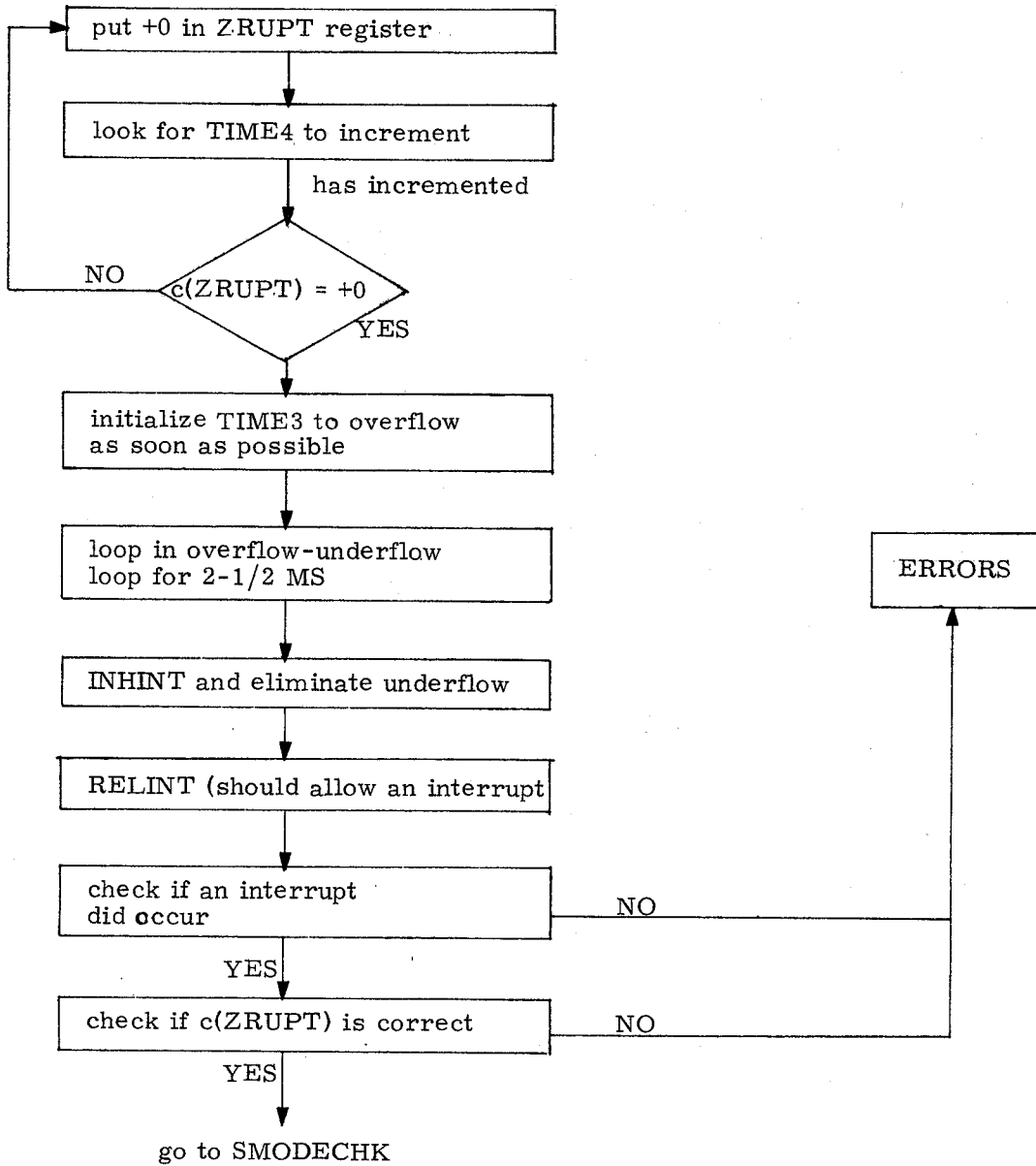

IN-OUT1

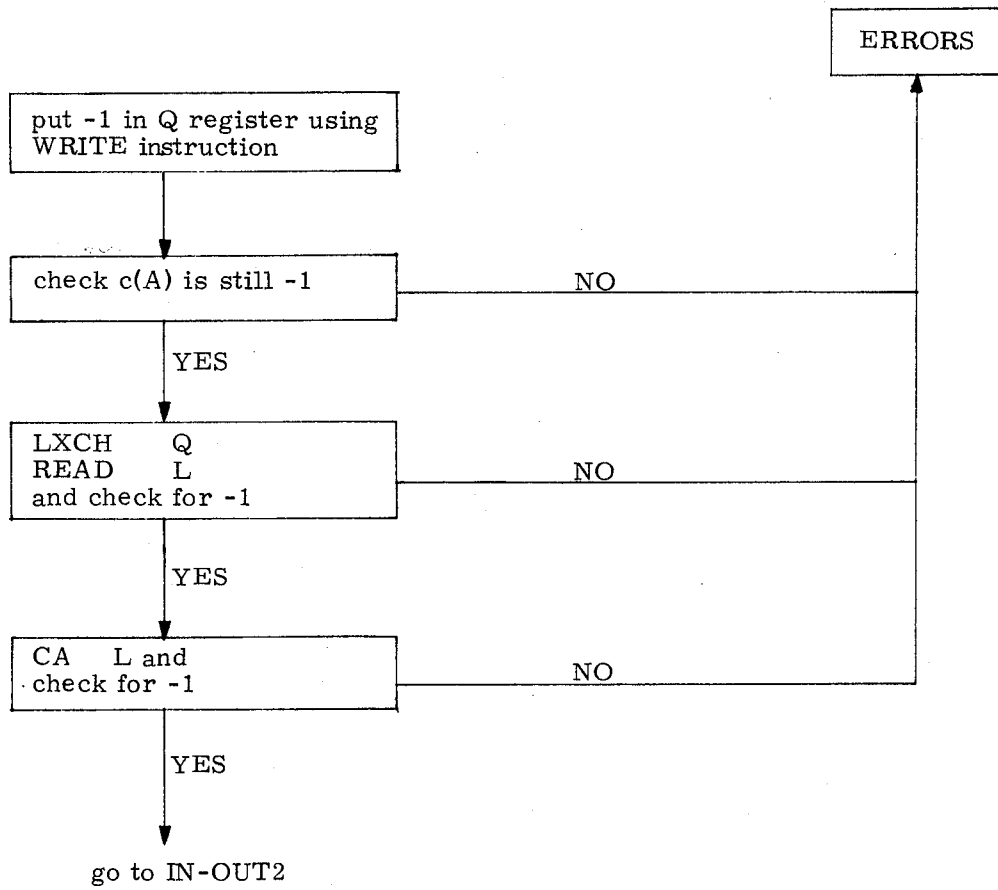

IN-OUT2

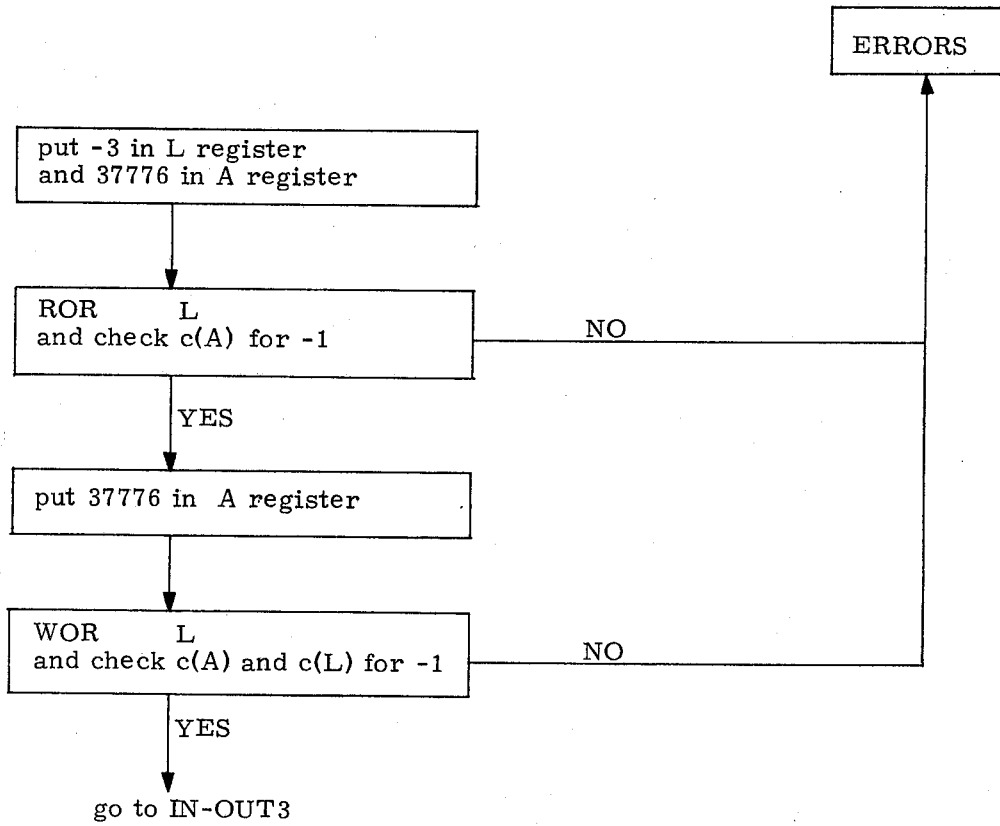

IN-OUT3

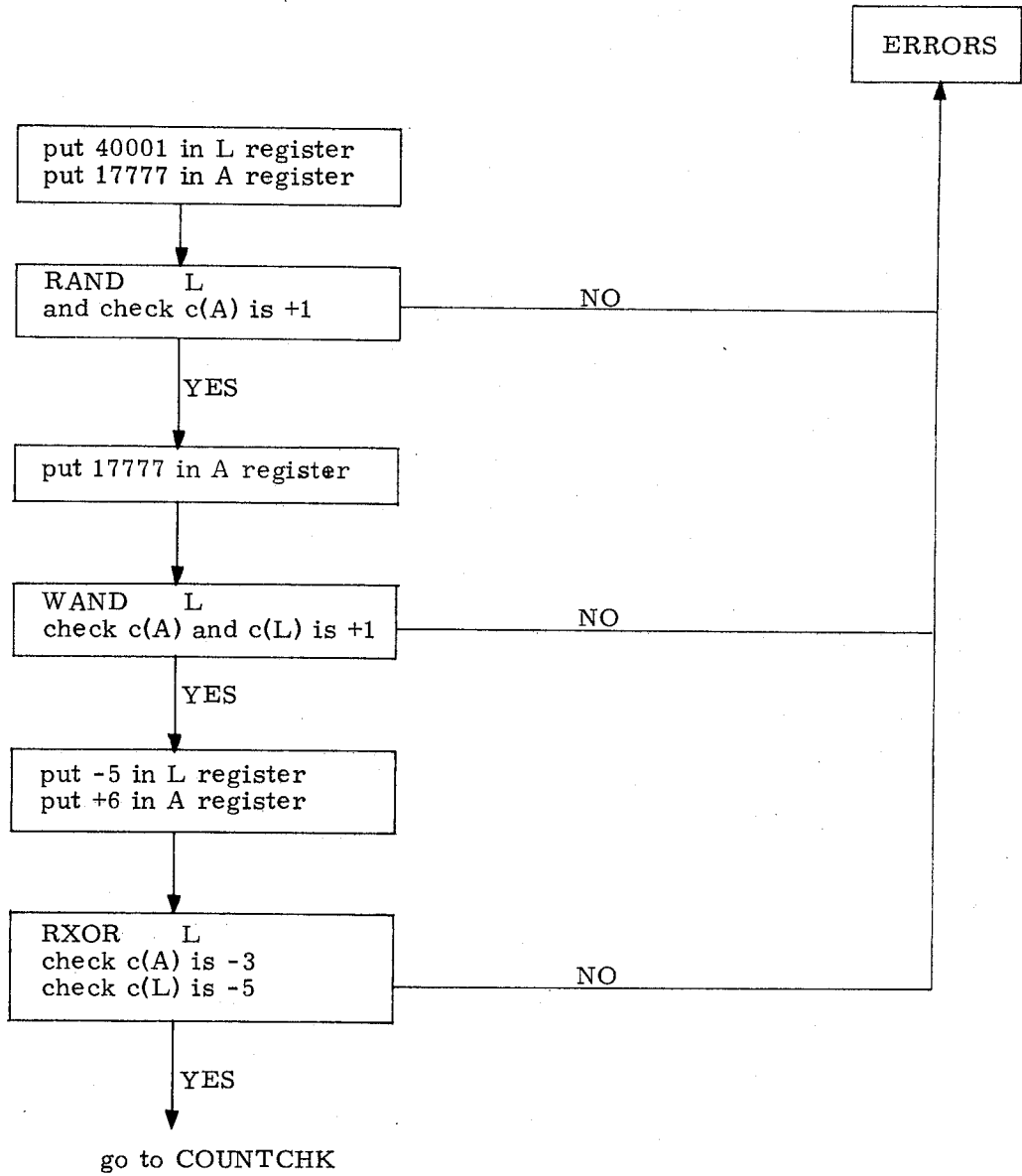

COUNTCHK

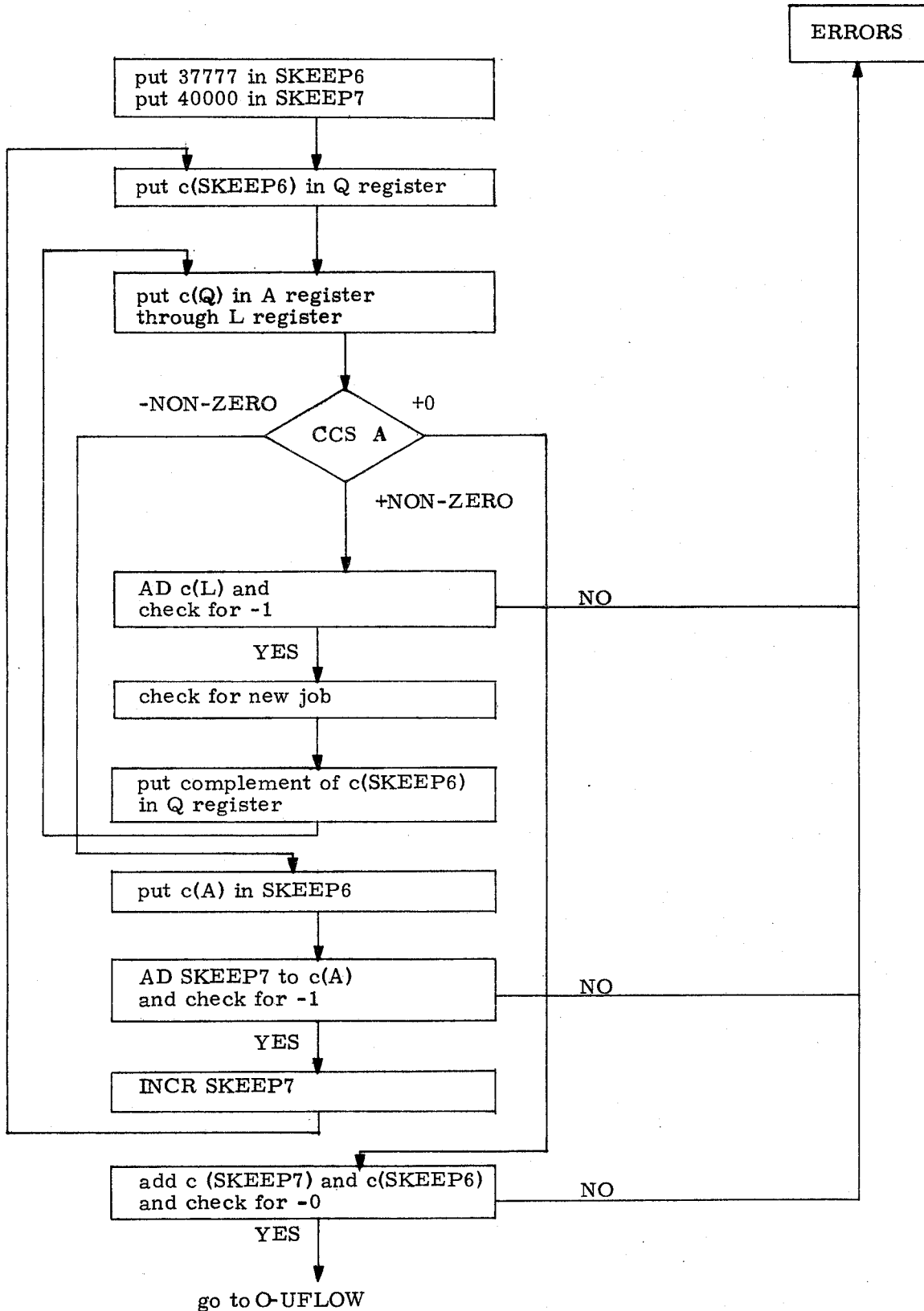

O-UFLOW

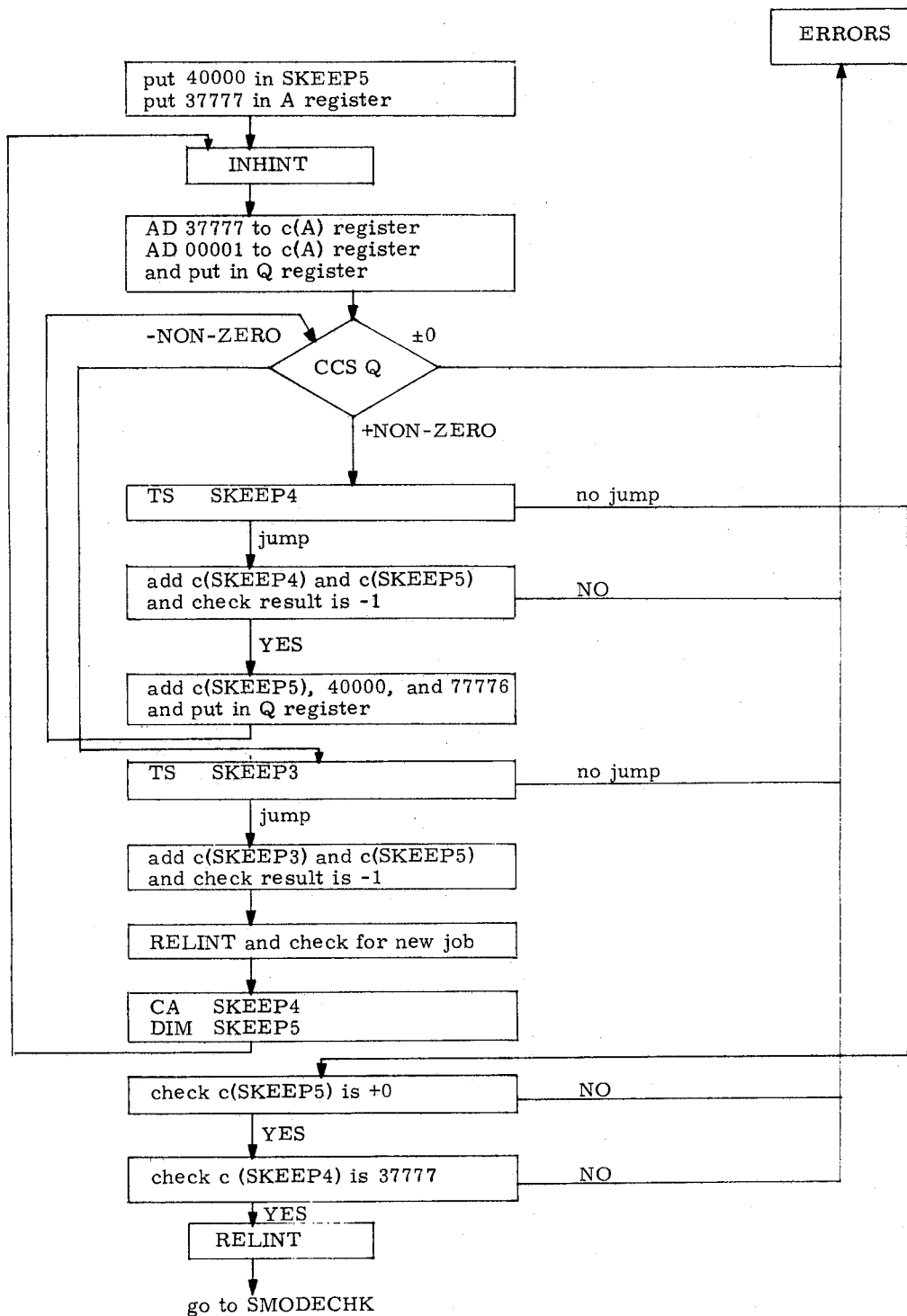

ERASCHK

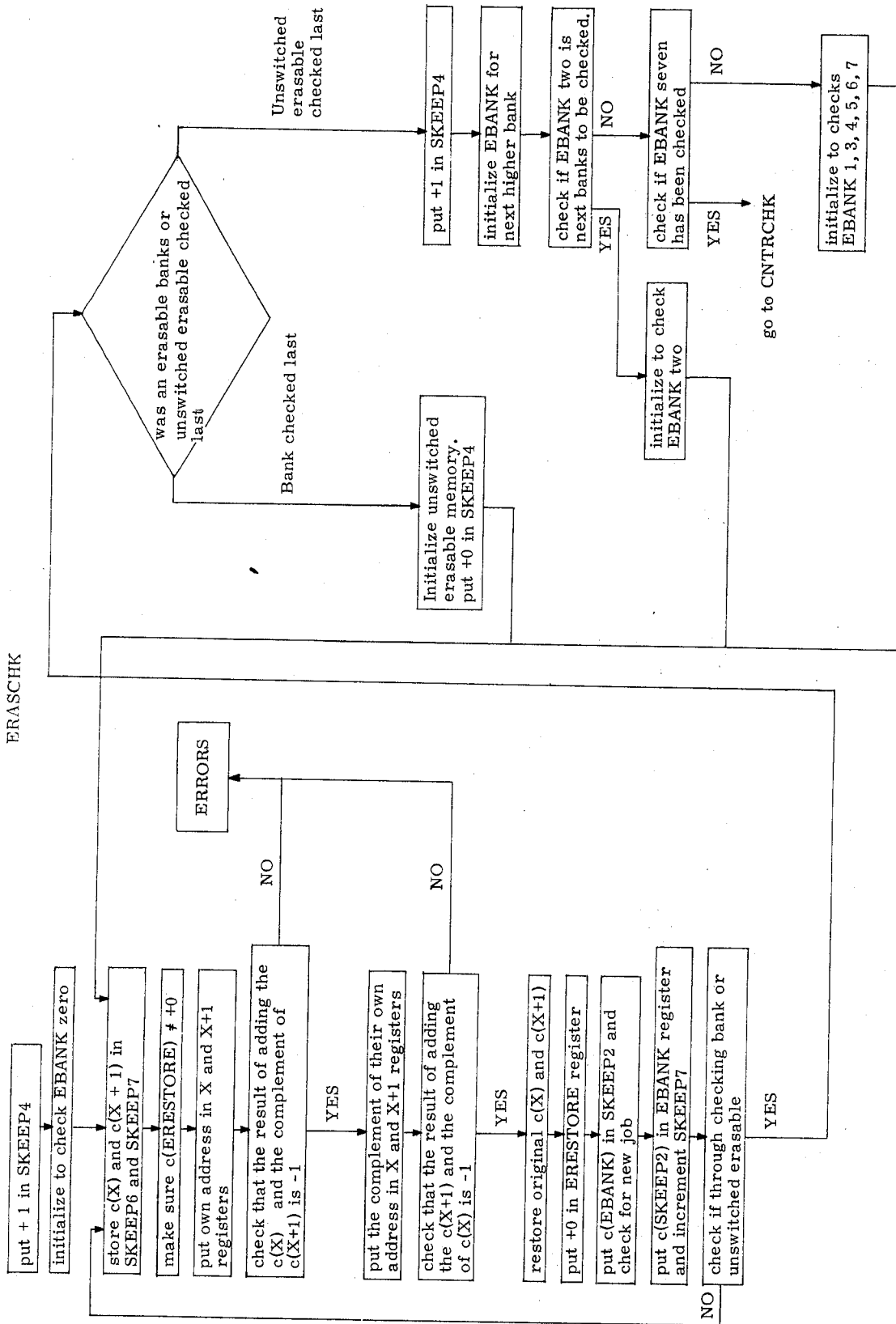

CNTRCHK

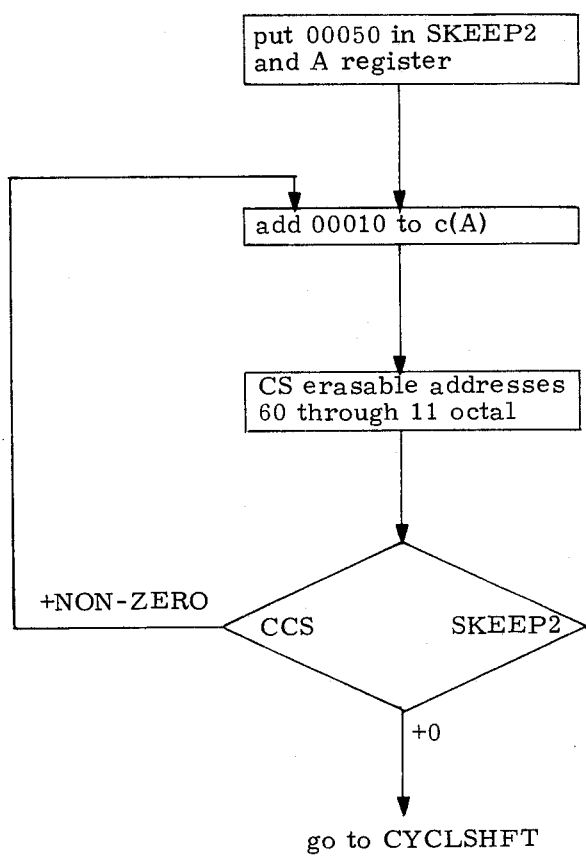

CYCLSHFT

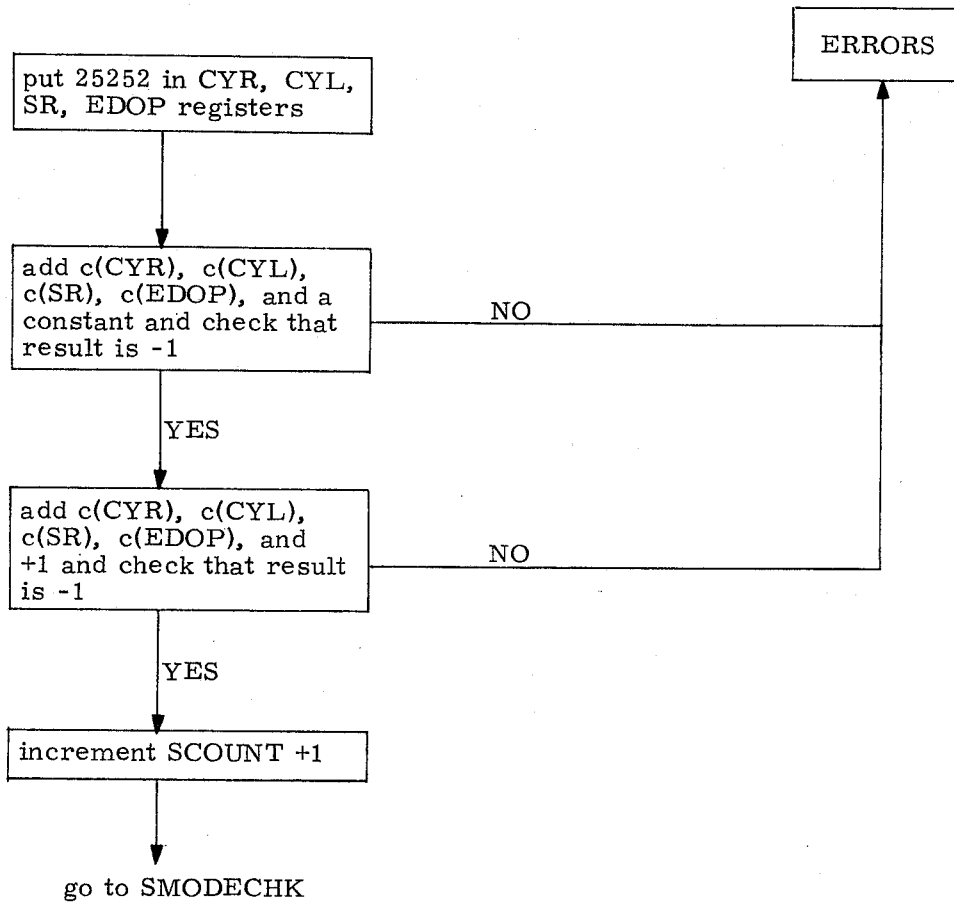

ROPECHK OR SHOWSUM

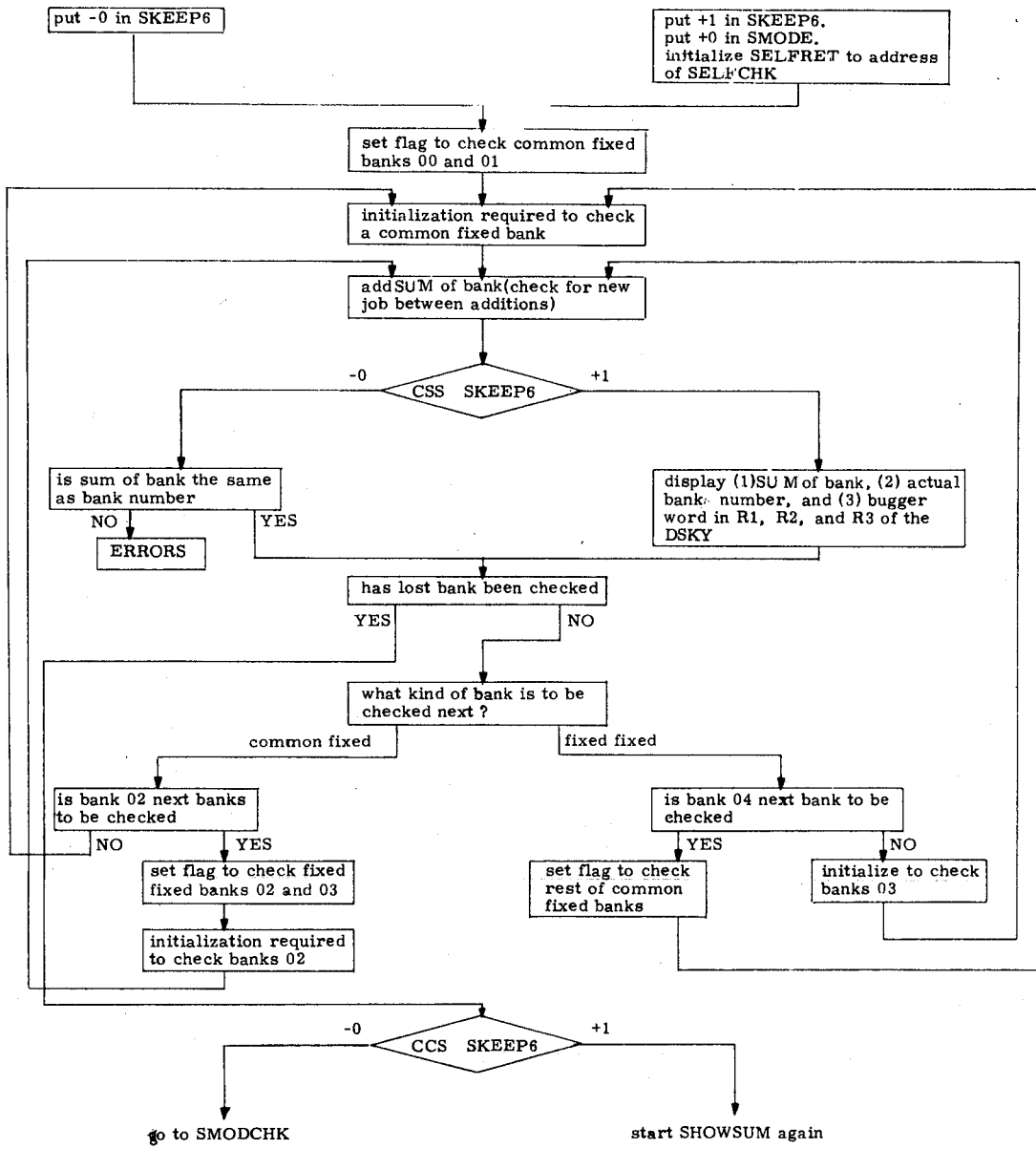

MPNMBRS

(20 second multiplier check)

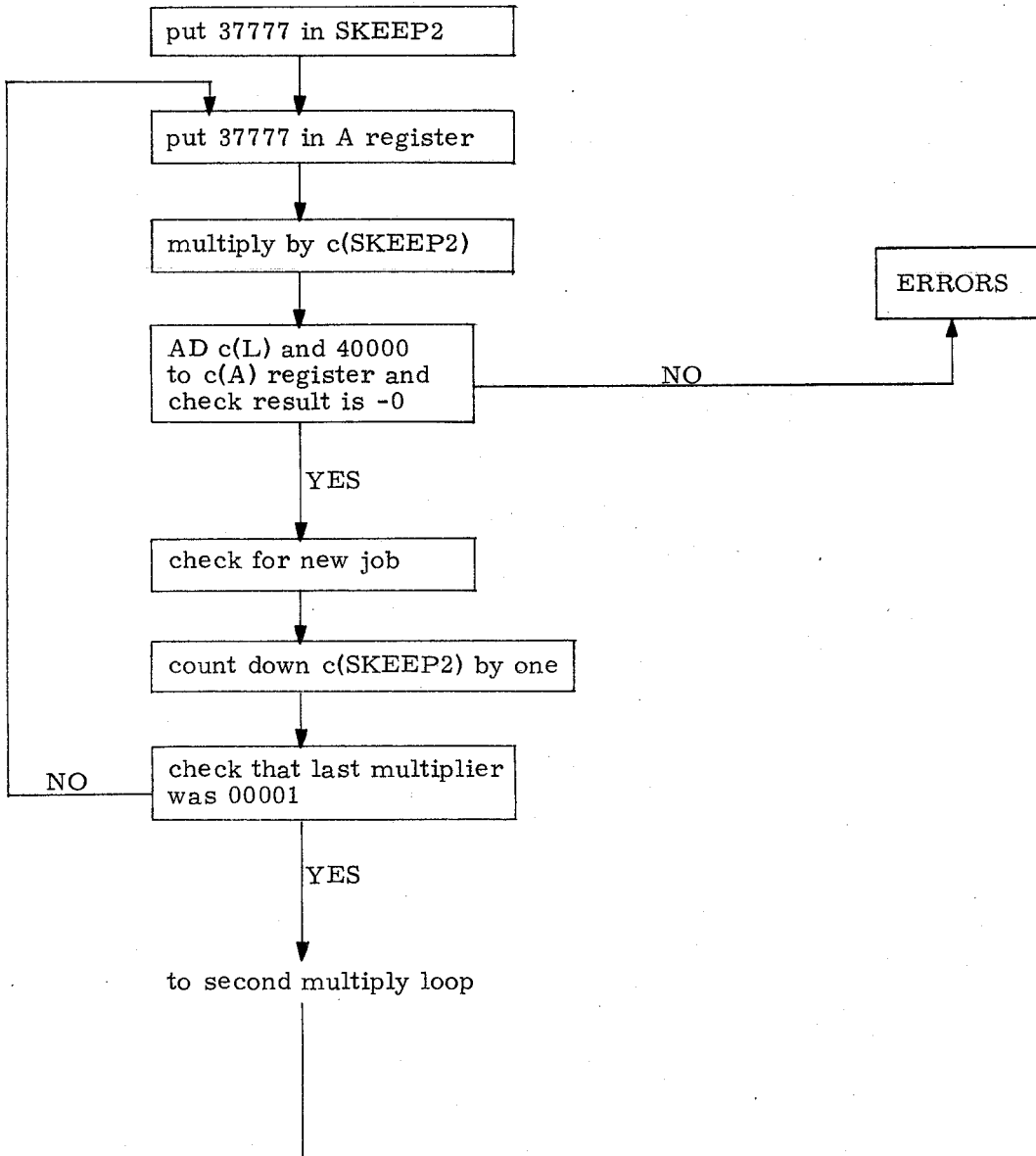

MPNMBRS (Cont'd)

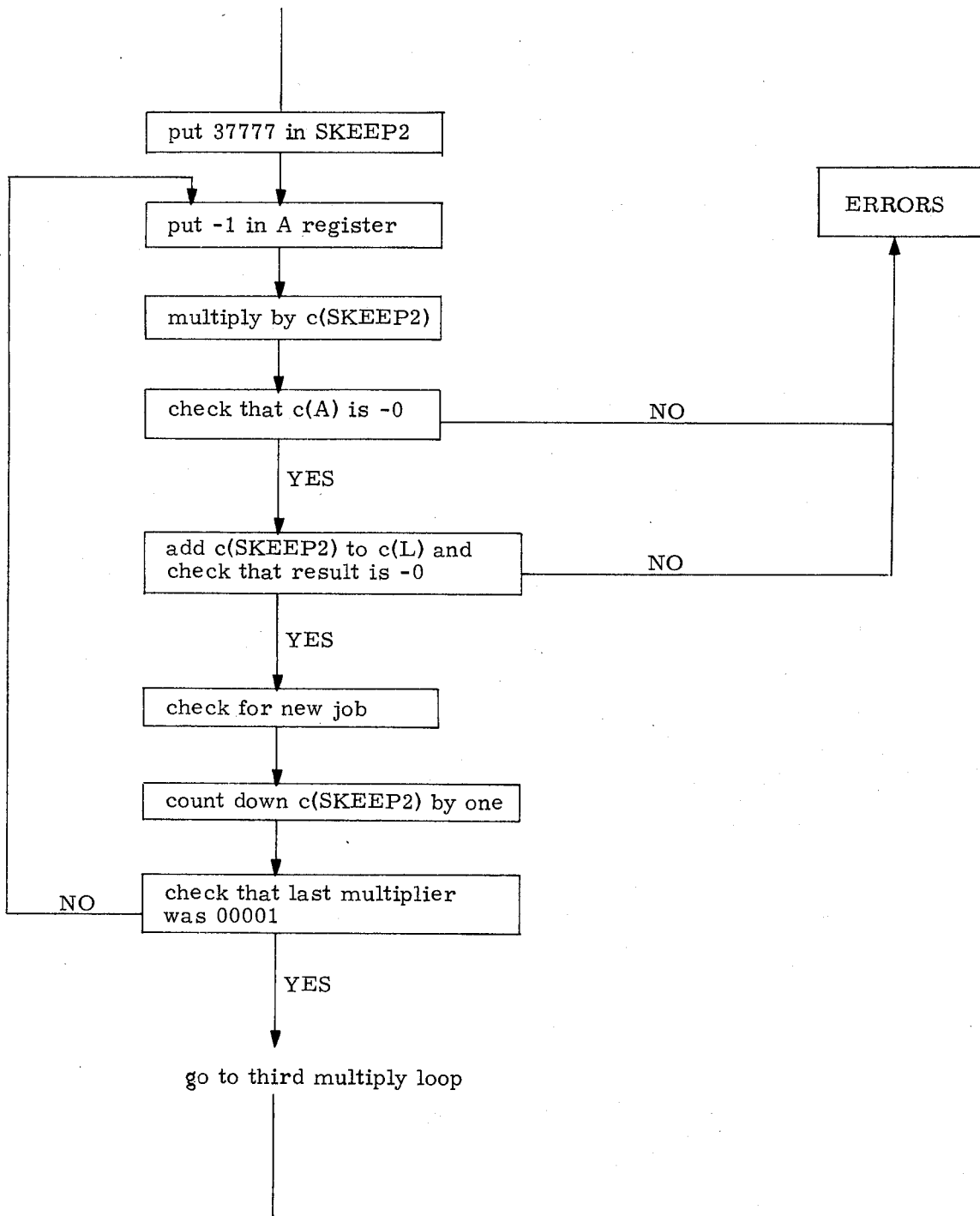

MPNMBRS (Cont'd)

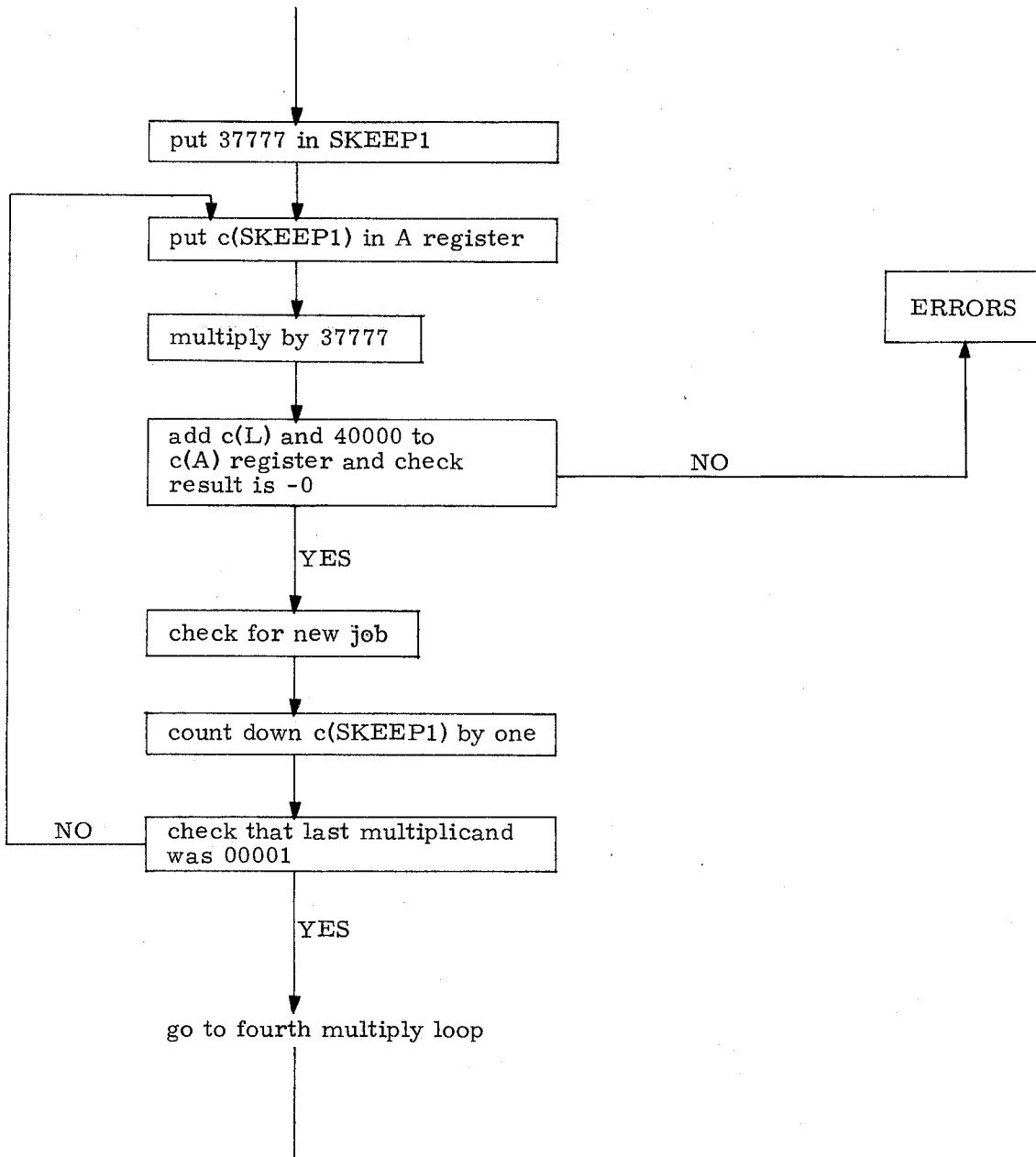

MPNMBRS (Cont'd)

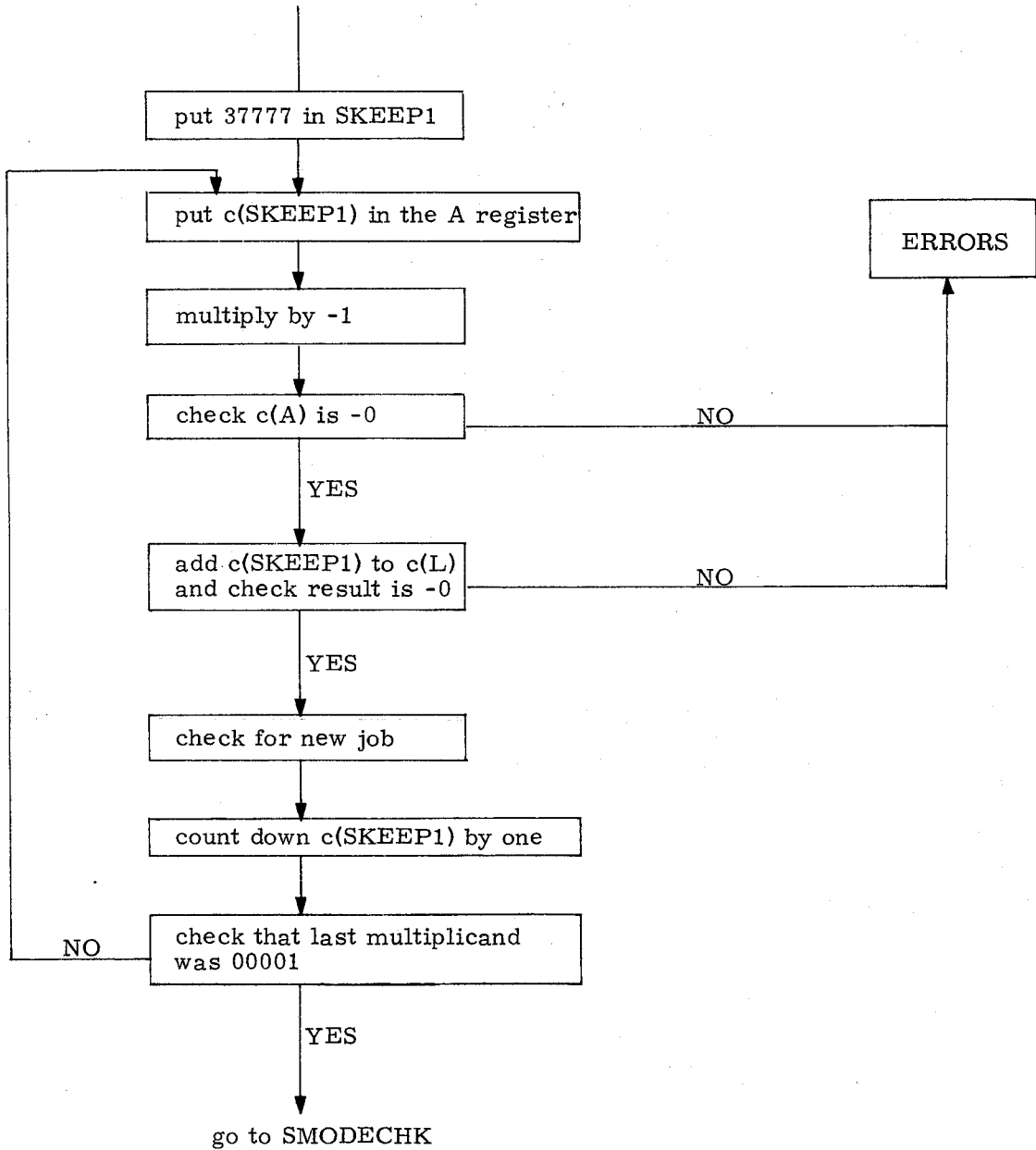

DVCHECK

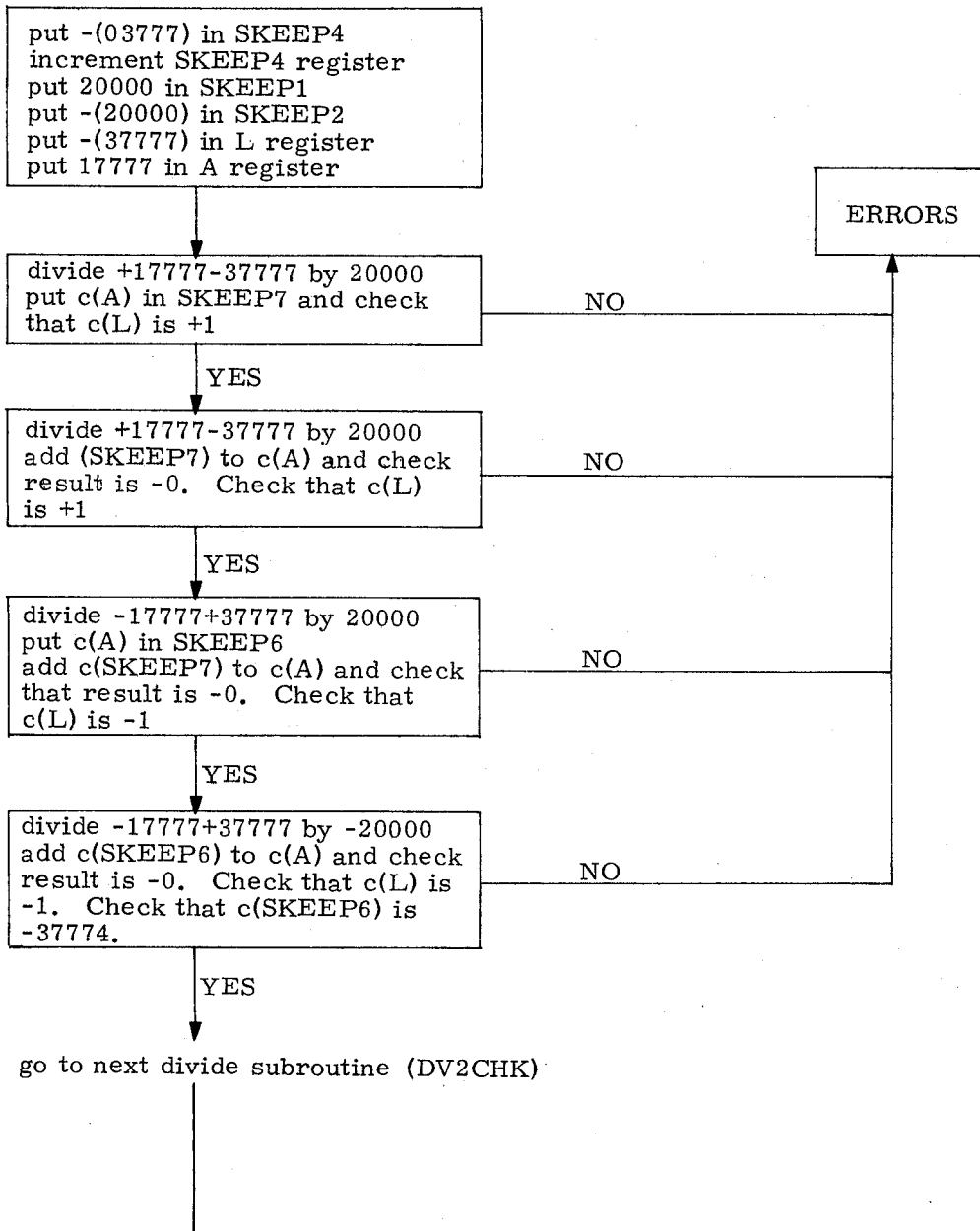

DVCHECK (Cont'd)

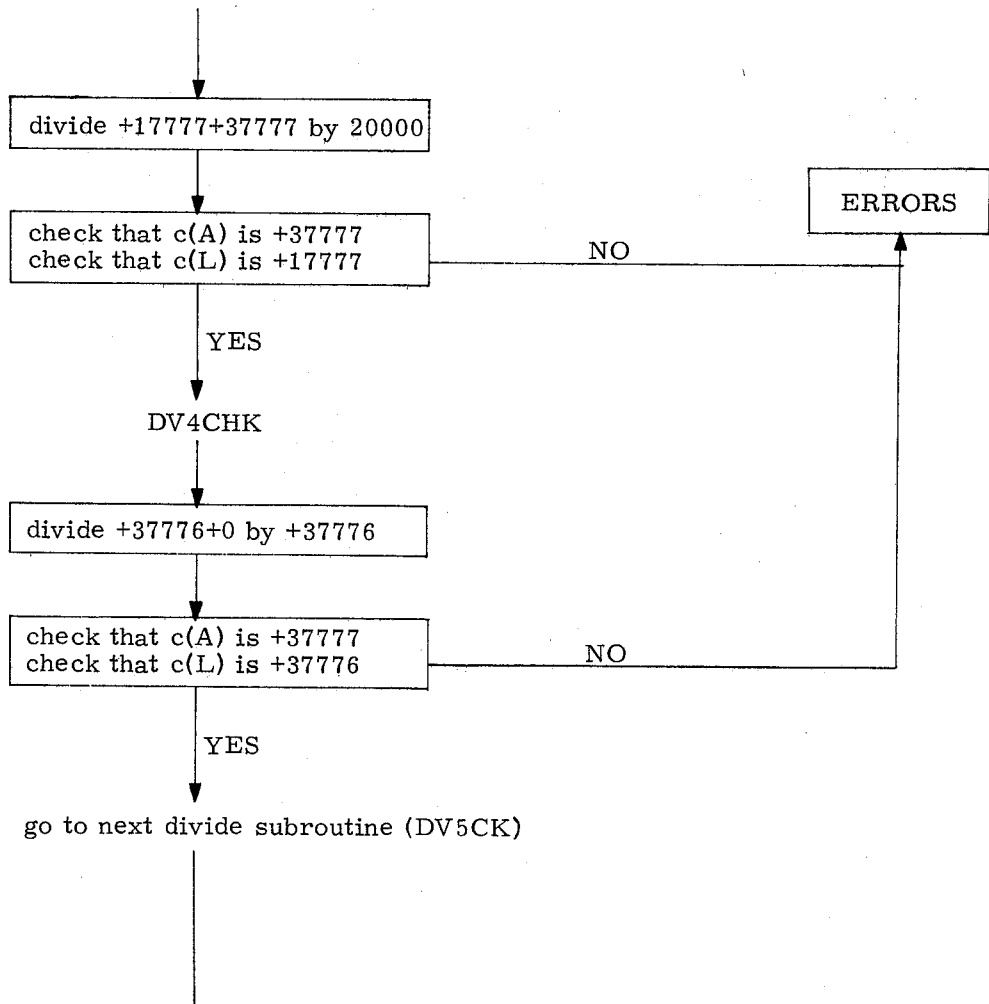

DVCHECK (Cont'd)

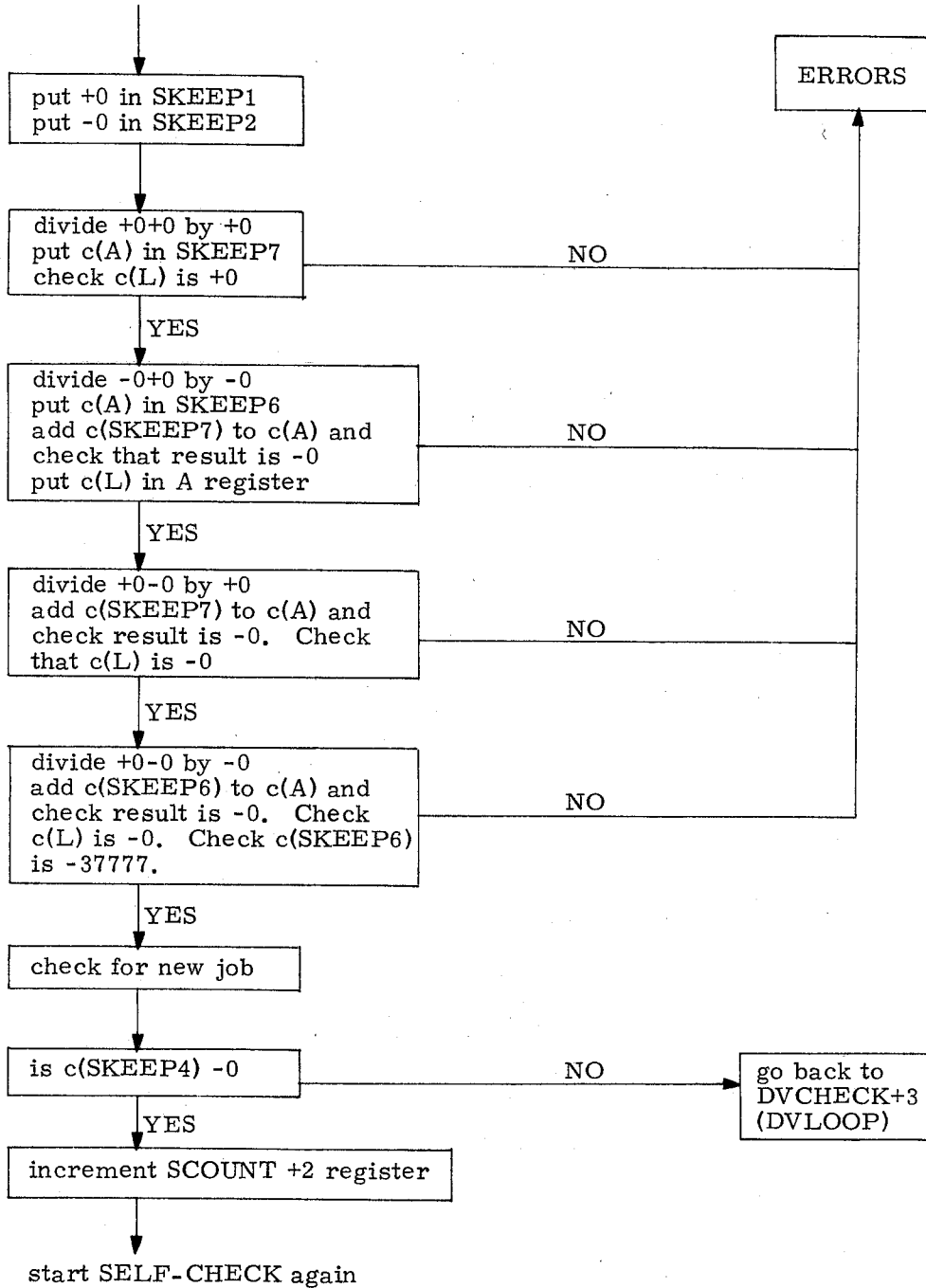

ROPECHK OR SHOWSUM

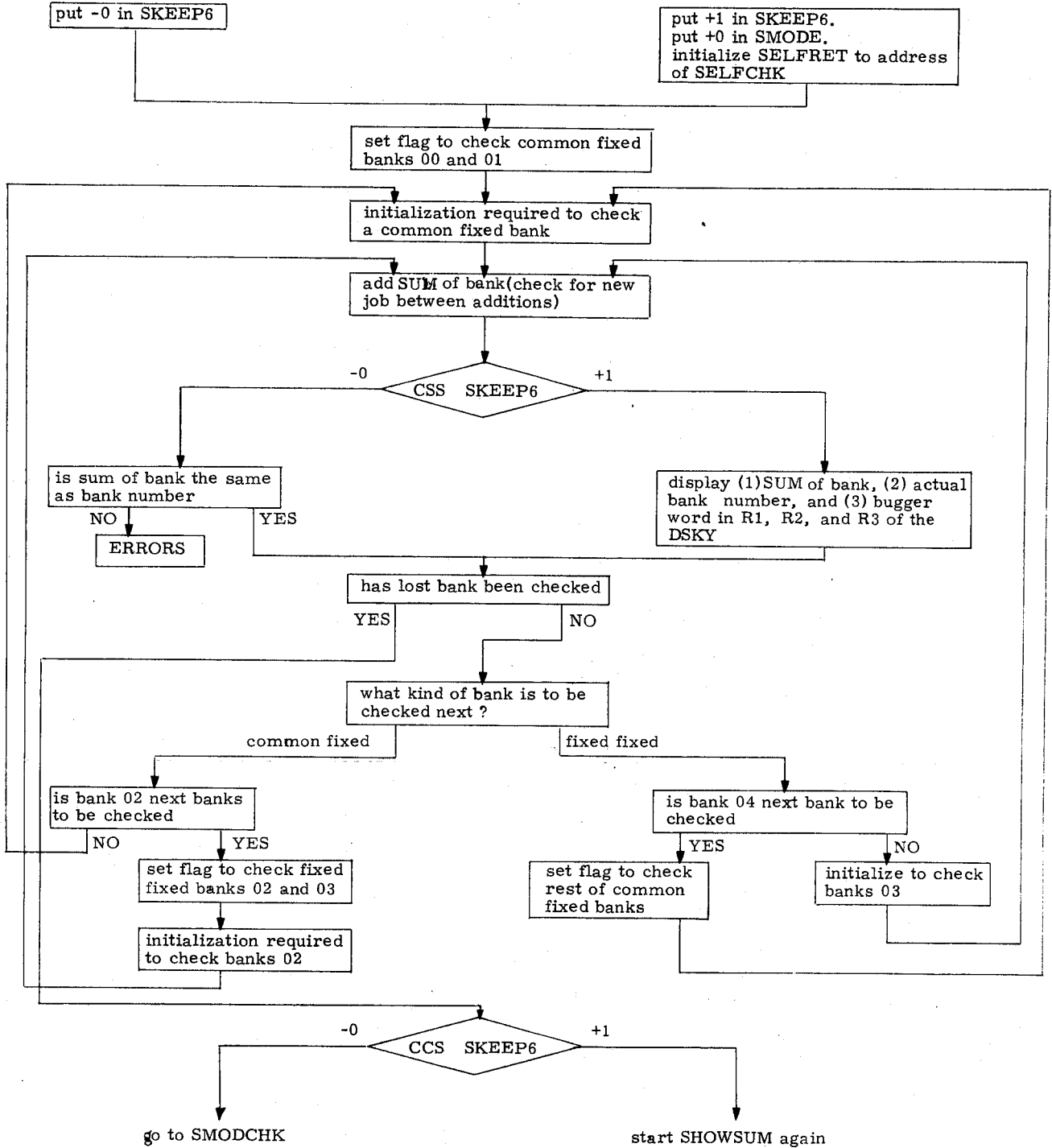

DSKYCHK

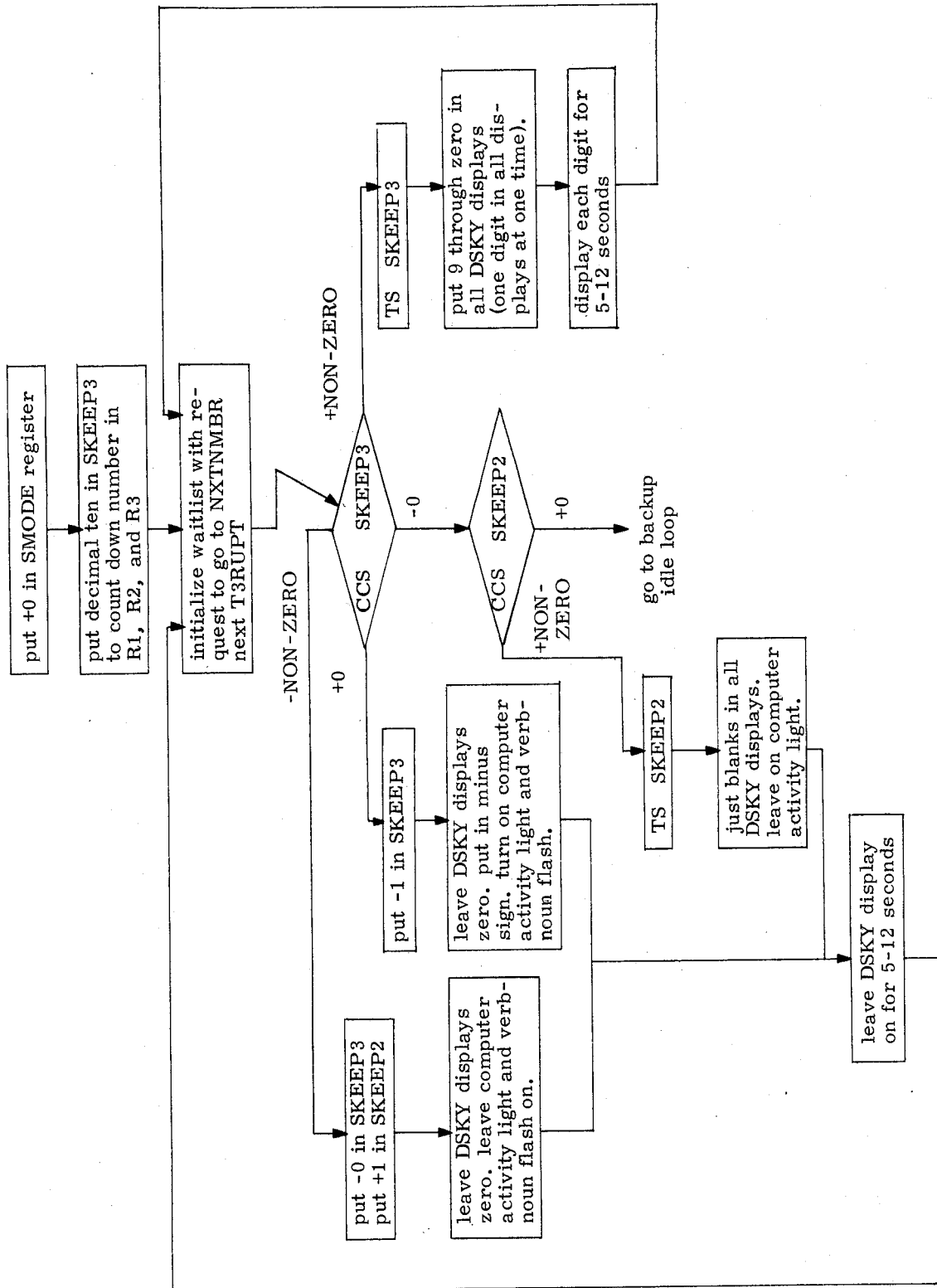

E-2065

DISTRIBUTION LIST

Internal

M. Adams (MIT/GAEC)	A. Green	J. Nevins
J. Alekshun	F. Grant	J. Nugent
R. Alonso	Eldon Hall	F. O'Glishen
R. Battin	T. Hemker (MIT/NAA)	M. Petersen
H. Blair-Smith	D. Hoag	R. Ragan
P. Bowditch/F. Siraco	A. Hopkins	G. Schmidt
D. Bowler	F. Houston	R. Scholten
R. Byers	L. B. Johnson	D. Scolamiero
G. Cherry	M. Johnston	N. Sears
E. Copps	A. Kosmala	J. Shillingford
R. Crisp	A. Laats	E. Smally (7)
J. Dahlen	A. LaPointe	W. Stameris
J. DeLisle	L. Larson	M. Trageser
G. Edmonds	S. Laquideira	R. Weatherbee
J. B. Feldman	T. M. Lawton (MIT/ MSC)	R. White
P. Felleman	D. Lickly	R. Woodbury
S. Felix	G. Mayo	W. Wrigley
J. Flanders	R. McKern	Apollo Library (2)
J. Fleming	James Miller	MIT/IL Library (6)
F. Gaunt (3)	John Miller	

External:

W. Rhine (NASA/MSC) (2)
NASA/RASPO (1)
AC Electronics (3)
Kollsman (2)
Raytheon (2)
Major H. Wheeler (AFSC/MIT) (1)

MSC: (25 + 1R)

National Aeronautics and Space Administration
Manned Spacecraft Center
Apollo Document Distribution Office (PA2)
Houston, Texas 77058

LRC: (2)

National Aeronautics and Space Administration
Langley Research Center
Hampton, Virginia
Attn: Mr. A. T. Mattson

GAEC: (3 + 1R)

Grumman Aircraft Engineering Corporation
Data Operations and Services, Plant 25
Bethpage, Long Island, New York
Attn: Mr. E. Stern

NAA: (18 + 1R)

North American Aviation, Inc.
Space and Information Systems Division
12214 Lakewood Boulevard
Downey, California
Attn: Apollo Data Requirements
Dept. 096-340, Bldg. 3, CA 99

NAA RASPO: (1)

NASA Resident Apollo Spacecraft Program Office
North American Aviation, Inc.
Space and Information Systems Division
Downey, California 90241

ACSP RASPO: (1)

National Aeronautics and Space Administration
Resident Apollo Spacecraft Program Officer
Dept. 32-31

AC Electronics Division of General Motors
Milwaukee 1, Wisconsin
Attn: Mr. W. Swingle

Defense Contract Administration (1)
Service Office, R
Raytheon Company
Hartwell Road
Bedford, Massachusetts 01730

Mr. S. Schwartz (1)
DOD, DCASD, Garden City
605 Stewart Avenue
Garden City, L. I., New York
Attn: Quality Assurance

Mr. D. F. Kohls (1)
AFPRO (CMRKKK)
AC Electronics Division of General Motors
Milwaukee 1, Wisconsin 53201