

MHI
Copy 3

FM 21-25

WAR DEPARTMENT

BASIC FIELD MANUAL



**ELEMENTARY MAP AND
AERIAL PHOTOGRAPH
READING**

April 12, 1941

FM 21-25

BASIC FIELD MANUAL



ELEMENTARY MAP AND AERIAL
PHOTOGRAPH READING

Prepared under direction of the
Chief of Engineers



UNITED STATES
GOVERNMENT PRINTING OFFICE
WASHINGTON : 1941

WAR DEPARTMENT,
WASHINGTON, *April 12, 1941.*

FM 21-25, Elementary Map and Aerial Photograph Reading, is published for the information and guidance of all concerned.

[A. G. 062.11 (12-9-40).]

BY ORDER OF THE SECRETARY OF WAR:

G. C. MARSHALL,
Chief of Staff.

OFFICIAL:

E. S. ADAMS,
Major General,
The Adjutant General.

DISTRIBUTION:

B and H (3) ; R (10) ; Bn (5) ; C (10).

TABLE OF CONTENTS

	Paragraphs	Page
SECTION I. General -----	1-5	1
II. Conventional signs and military symbols -----	6-7	3
III. Map measurements -----	8-10	11
IV. Direction and azimuth -----	11-20	15
V. Location by coordinates -----	21-24	29
VI. Elevation and relief -----	25-32	35
VII. Map reading in the field -----	33-38	54
VIII. Aerial photograph reading -----	39-48	70
APPENDIX -----		97
INDEX -----		99

BASIC FIELD MANUAL

ELEMENTARY MAP AND AERIAL PHOTOGRAPH
READING

(This manual supersedes chapter 5, Basic Field Manual, volume I, April 2, 1938.)

SECTION I

GENERAL

■ 1. PURPOSE.—The purpose of this manual is to present in simplified form necessary information for instruction of all military personnel in elementary map and aerial photograph reading.

■ 2. SCOPE.—*a.* This manual covers elementary map reading, including conventional signs and military symbols, distances and scales, directions and azimuths, coordinates, relief, slopes, profiles and visibility, map reading in the field, and aerial photograph reading to an extent sufficient to permit soldiers and platoon leaders to read aerial photographs and aerial mosaics.

b. FM 21-26 takes up the subject where this manual stops, and covers more technical phases of the subject. Other publications of a general nature pertaining to maps, mapping, and aerial photograph reading are listed in the appendix.

■ 3. NECESSITY FOR TRAINING.—Modern warfare makes it essential that personnel of all grades have the ability to read maps and aerial photographs. The detailed study of maps assists higher commanders in arriving at their tactical decisions. In transmitting orders, they often will use maps which outline their plans to their subordinate commanders. In order to carry out these orders intelligently, the subordinate commanders must be able to read any type of map involved. Maps are used to move various combat units to their assigned positions and to identify their boundaries, areas, and objectives. The supporting fires of many weapons are usually controlled by use of map data. Frequently soldiers will be given individual missions requiring them to travel long distances with only a map as a guide. Since aerial photographs or photomaps made from aerial photographs are

constantly being used as maps or to supplement maps, the necessity for training in their use is equally important as training in use of maps.

■ 4. MAPS AND AERIAL PHOTOGRAPHS.—Types of maps or aerial photographs generally issued to troops will vary a great deal depending on location of operations. Large scale topographic maps desirable for tactical operations of small units exist for only limited areas, so some of lesser accuracy normally may be expected. These may range from ordinary automobile road maps to some type of map substitute. Various types of maps and map substitutes which may be encountered are—

a. *Maps compiled from existing maps.*—Normally troops may expect to be furnished some type of map hastily compiled from such maps as exist at the outbreak of hostilities. These maps may vary from crude, small scale maps such as ordinary automobile road maps to accurate, large scale, topographic maps. Large scale topographic maps suitable for tactical operations of small units may be expected only in isolated areas of limited size.

b. *Map substitutes.*—This is a general term used to designate substitute maps that may be produced in a few hours. The map substitute may consist of direct reproduction of wide coverage aerial photographs, photomaps or mosaics, or of provisional maps. The term "photomap" is used as a general term to describe reproductions of various types of aerial photographs. A provisional map is produced by compiling existing map detail or by tracing information from aerial photographs.

c. *Battle maps* (fig. 1) (back of manual).—This is a map prepared normally from aerial photographs on a scale of 1:20,000, which is suitable for tactical and technical needs of all arms. Normally, this type of map would not be made available for any extensive area until at least 3 weeks after outbreak of hostilities.

■ 5. MAP CLASSIFICATION.—Military maps are generally classified according to scale as small, intermediate, medium, and large scale. (For a discussion of scales, see par. 8.) The battle map (fig. 1) referred to in paragraph 4c, is classed as

a large scale map. The compiled map described in paragraph 4a will probably be of a scale from 1:50,000 to 1:125,000, which is classed as a medium scale map. Figure 2 (back of manual) is an example of a medium scale map. Small and intermediate scale maps are used by staffs of larger units and seldom will concern commanders of small units.

SECTION II

CONVENTIONAL SIGNS AND MILITARY SYMBOLS

■ 6. CONVENTIONAL SIGNS.—*a.* Map makers have devised a common set of signs which to the map reader have a definite meaning. For instance, there are signs for a house, for a road, for a bridge, etc. These are called conventional signs. Some of them look enough like the object they are intended to represent to be easily recognized such as conventional signs for lakes or bridges. The meanings of some are not so obvious and must be learned just as new words are learned. Complete lists of conventional signs authorized for use on military maps are published in FM 21-30. Figure 3 shows some of those most commonly used.

b. Conventional signs vary in size with the scale of maps. On small scale maps comparatively few objects can be shown and the signs are reduced to their most elementary form. As the scale is increased more objects can be represented.

c. Locations of some objects are shown with more accuracy than others due to manner in which the topographer and map draftsman work. Some of these in order of accuracy are—

- (1) Triangulation stations.
 - (2) Surveying monuments.
 - (3) Railroads and canals.
 - (4) Important bridges.
 - (5) Main roads.
 - (6) Isolated buildings on main roads, including churches and schoolhouses.
 - (7) Secondary roads.
 - (8) Streams, contours, and woodlands, cleared areas, etc.
- In choosing landmarks for determining location, these relative values should be kept in mind.

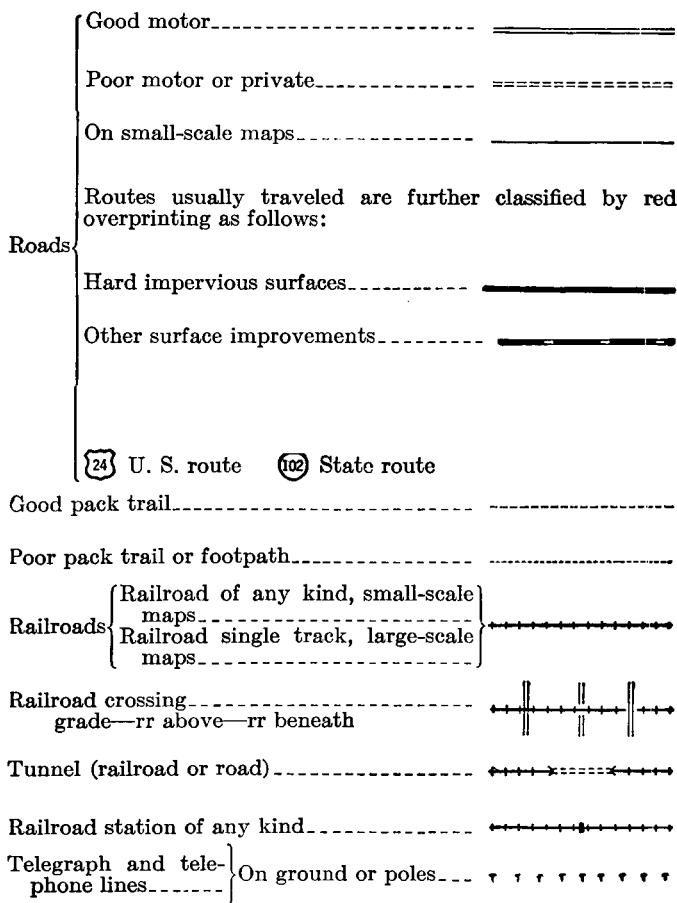

FIGURE 3.—Conventional signs.

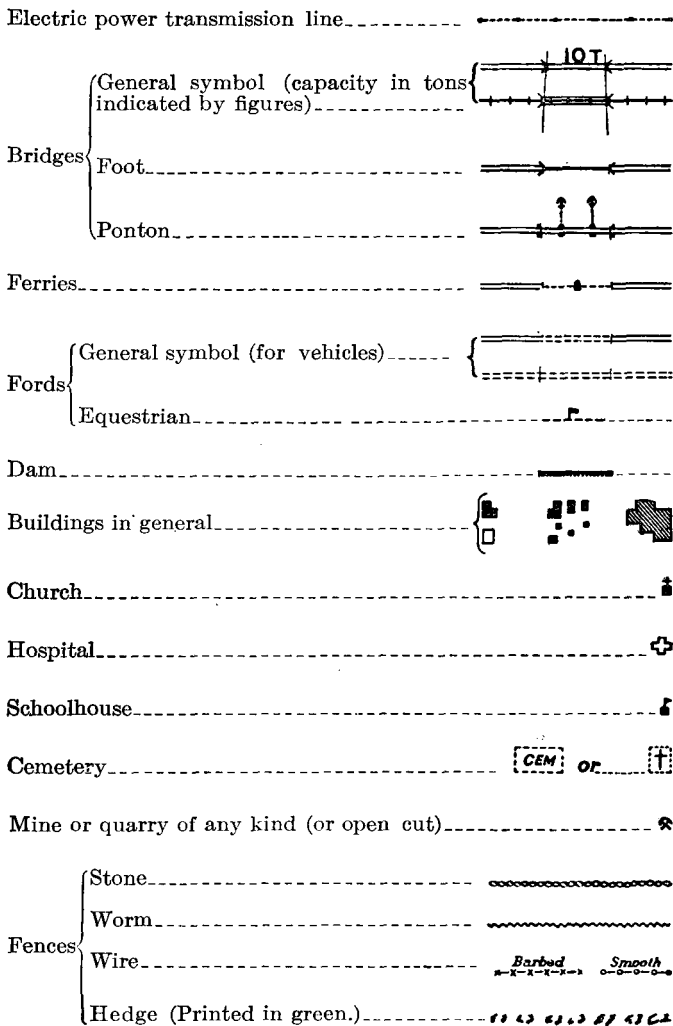

FIGURE 3.—Conventional signs—Continued.

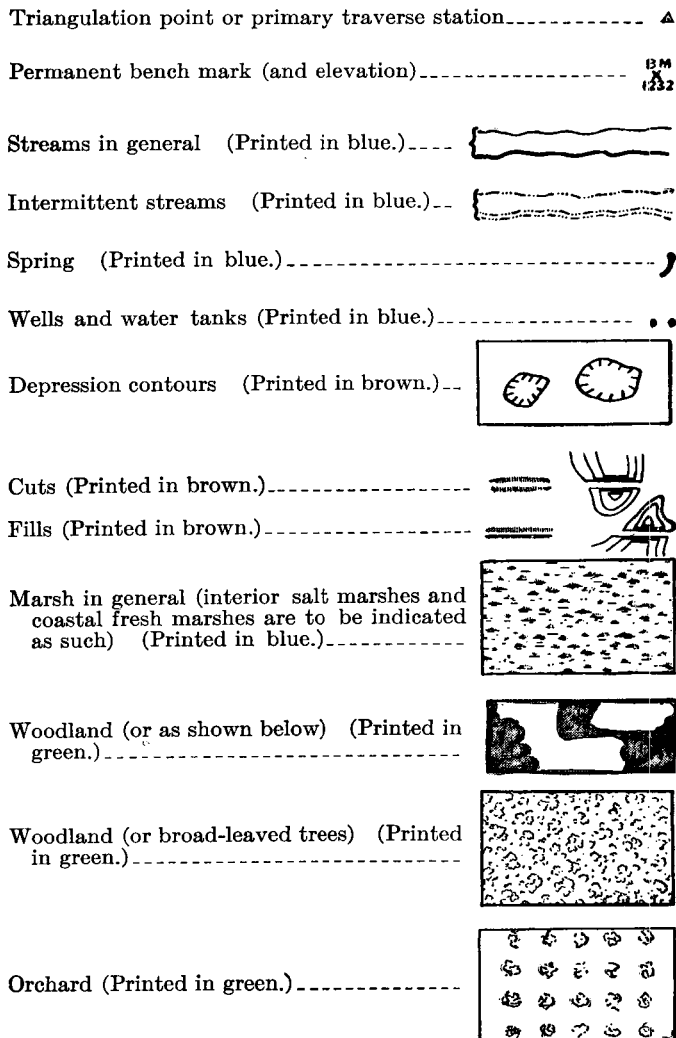



FIGURE 3.—Conventional signs—Continued.

d. When colors are used for War Department maps, they are used as follows: black for works of man and for grid lines; brown for contours, cuts, and fills; blue for water; green for woods and vegetation; red to indicate road conditions.

■ 7. MILITARY SYMBOLS.—Conventional signs indicate various types of terrain features. Military symbols have been developed to represent various types of military organizations, activities, and installations. FM 21-30 lists various standardized military symbols. Figure 4 shows some of those most frequently used. These symbols are used to indicate size and identity of various units and installations, type and location of supporting weapons, and necessary lines and boundaries for an operation. A material saving of time in giving orders for military operations may be achieved by using military symbols to outline operations on a map or a map substitute.

1. To indicate purpose or character of activity.

Military post or station; command post or headquarters... 
 (Lower end of staff or symbol will terminate at point of establishment represented.)

Troop unit..... 
 (On large scale maps where troop units can be shown to scale, this symbol may be modified so as to show area occupied by units in column or line, thus:

Line  Column .)

Observation post..... 

Dump, park, or distributing point (temporary depot in combat zone)..... 

Supply train or transportation unit..... 

2. To indicate arm or service or activity of arm or service.—These symbols will be placed generally within the symbols shown in 1 above.

Air Corps..... 

Armored Force..... 





FIGURE 4.—Special military symbols.

Artillery	●
Cavalry	/
Chemical Warfare Service	G
Engineers	E
Infantry (except military police)	X
Military police	MP
Medical Department	+
Ordnance Department	T
Ammunition only	⊙
Prisoners of war	PW
Quartermaster Corps	Q
Class I supplies	⊖
Gasoline and oil only	⊖
Signal Corps	S
3. <i>To indicate size of units.</i> —These symbols will be placed above the symbols shown in 1 above, or used for indicating boundaries as shown in 4 below.	
Squad
Section
Platoon
Company, troop, battery, or Air Corps flight	I
Battalion, cavalry squadron, or Air Corps squadron	II
Regiment or Air Corps group	III
Brigade or Air Corps wing	X
Division	XX
Corps	XXX
Army	XXXX

FIGURE 4.—Special military symbols—Continued.

General headquarters.....	GHQ
4. To indicate boundaries.	
Squad.....	— —
Section.....	—•••—
Platoon.....	—••••—
Company or similar unit.....	— —
Battalion or similar unit.....	— —
Regiment or similar unit.....	— —
Brigade.....	—X—
Division.....	—XX—
Front line.....	
Limit of wheeled traffic by day.....	—DY—
Limit of wheeled traffic by night.....	—NT—

5. Miscellaneous.

Area, gassed, to be avoided.....	
Automatic rifle.....	
(Dotted when emplacement is not occupied, thus).....	
Machine gun.....	
(Arrow to point in principal direction of fire. When used alone it indicates machine gun, water-cooled, cal. .30.)	
Machine-gun symbol under symbol of unit of any arm indicates machine-gun unit of that arm.	
Caliber .50 (antitank).....	

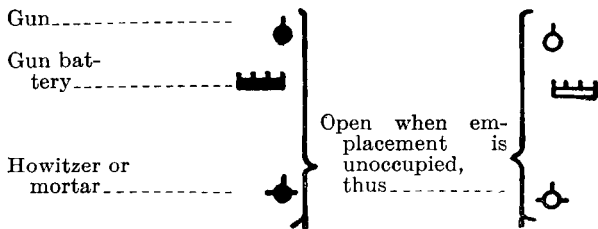











FIGURE 4.—Special military symbols—Continued.

37-mm gun.....		37-mm
(AT or AA to be added where applicable.)		
81-mm mortar.....		81-mm
Machine gun (single gun).....		
(Arrows to indicate sectors of fire, shaded portion to show danger space when fire is placed in final protective line.)		
Machine-gun section (two guns).....		
Message center.....		
Tank trap.....		
Traffic:		
One-way.....		
Two-way.....		
Trench for one squad.....		
(For each additional squad add one traverse.)		

6. Application of special symbols.













Light Machine-Gun Platoon, Troop A, 2d Cavalry.....		A	2
Machine-Gun Troop, Caliber .50, 2d Cavalry.....			2
Troop F, 2d Cavalry.....		F	2
Company A, 2d Engineers (combat).....		A	2
Battery F, 2d Field Artillery.....		F	2
One squad, Company A, 4th Infantry.....		A	4
Light Machine-Gun Section, Company A, 2d Infantry..		A	2
1st Platoon, Company B, 2d Infantry.....		1B	2
Machine-Gun Platoon, Caliber .50, Company H, 29th Infantry.....		3H	29
Headquarters Company, 3d Infantry.....		HQ	3
Company D, 20th Infantry.....		D	20
Command Post, 3d Battalion, 4th Infantry.....		3	4
Observation Post, 6th Infantry.....			6

FIGURE 4.—Special military symbols—Continued.

SECTION III

MAP MEASUREMENTS

■ 8. SCALES.—In map reading the scale of the map is a first consideration. The scale is the relation between measurements on the map and actual distances on the ground. The scale of a map is expressed in one or more of the following ways:

a. Words and figures.—Actual equivalents given in words and figures as 3 inches equal 1 mile means that 3 inches on the map equal 1 mile on the ground; 1 inch equals 200 feet means that 1 inch on the map equals 200 feet on the ground.

b. Representative fraction.—The scale of a map may be shown as a representative fraction (usually abbreviated to RF). This fraction expresses the ratio between a given distance on a map and the corresponding distance on the ground.

The RF is shown thus: 1:62,500 or $\frac{1}{62,500}$ which means one unit of distance on the map equals 62,500 such units of distance on the ground. The same kind of units of distance measured from the map must be applied to distances on the ground. For instance, in the RF shown above, 1 inch on the map equals 62,500 inches (or about 1 mile) on the ground and 1 foot on the map equals 62,500 feet (or about 12 miles) on the ground. The greater the denominator the smaller the scale; a 1:20,000 map is a large-scale map, and a 1:1,000,000 is a small-scale map.

c. Graphic scales.—The figure resembling a small ruler printed on the map is also called a scale (see fig. 5). It is divided into parts, each division being marked not with its actual length but with the distance each length represents on the ground. Usually there will be one part graduated into mile units and fractions of a mile. The other part is graduated in yards for more exact measurements of ranges, frontages, and depths. Many maps also show the kilometer scale, but this normally is used only in countries where the metric system is employed. Each graphic scale consists of a primary scale to the right of zero, and an extension to the left of zero. The extension consists of one primary unit of

the graphic scale subdivided into appropriate fractions. Typical graphical scales as used on American maps can be seen on the lower margin of figure 2 (back of manual). The scale in figure 5 has 1,000-yard units for the primary scale and ten 100-yard units for the extension.

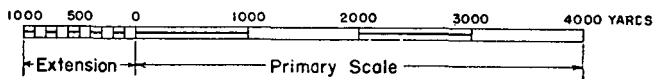

FIGURE 5.—Graphic scale for measurement in yards.

■ 9. DISTANCE.—Once the scale of the map is known, distances on the ground which are represented on the map can be determined. Even though the scale is given in words and figures or as a R_F, some sort of graphic scale is usually necessary. The graphic scale is the most accurate and the most common means of determining distances from a map. Some methods of employing the graphic scale follow:

a. To find distance between two points on map (fig. 6).—

(1) Lay the straight edge of a piece of paper or other material along the two points on the map. Mark the location of the two points on the straightedge by using short straight marks called "ticks" at right angles to the edge of the paper.

(2) Take the marked straightedge and place it below the graphic scale on the margin of the map to determine the ground distance required. Where the distance is greater than the length of the graphic scale, apply the primary scale one or more times until the remainder can be measured as explained above. Distances between the smallest divisions of the scale are estimated.

(3) Example.—(a) Problem.—Figure 6① shows a portion of a 1:20,000 map. Required, to find actual distance on the ground between the house at A and the house at B.

(b) Solution.—Lay the straightedge of a strip of paper along A and B on the map and make tick marks. Take the strip of paper and lay its marked edge along the graphic scale on the margin of the map as shown in figure 6②. The required distance between ticks is read directly from the scale as 3,160 yards.

b. To find distance along irregular line of map.—It is sometimes necessary to measure the distance along irregular lines on a map such as a stream or a winding road. To do this, either divide the line into several approximately straight sections or, if a piece of transparent paper is available, proceed

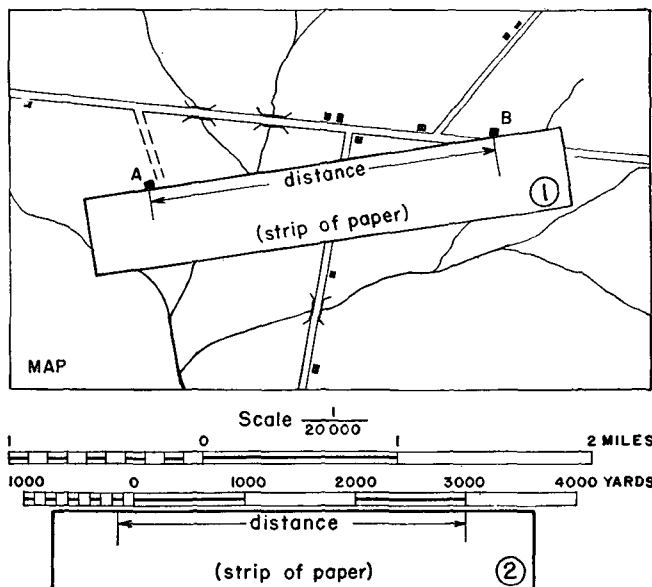

FIGURE 6.—Using graphic scale to measure distance on map.

as in (2) below. Measure the length of each section as in *a*(2) above. The sum of the lengths of the sections is the required distance.

(1) *Example.*—(a) *Problem.*—Required, to find distance along winding road shown in figure 7.

(b) *Solution.*—Take a suitable strip of paper and place it so that a tick mark along its edge coincides with A, and the edge of the paper coincides with the course A-1. Make a tick mark -1 on the paper opposite the point 1 on the map. With mark -1 on the paper held opposite 1 on the map, rotate the paper until its edge is along the line 1-2. Make

a second mark on the paper opposite 2 on the map. Continue this until B is reached; the entire distance is measured as in *a* above.

(2) *Example*.—This method also describes how to measure the distance A-B on figure 7. By means of a straightedge and a sharp pencil draw a long straight line generally down the center of any transparent piece of paper. For a starting point, draw a straight line (tick) perpendicular to and near one end of the first line. Lay the paper on the road with the starting tick over A so that the long line extends through 1. Place the pencil point at 1 and pivot the paper until the long line lies along the course 1-2. Place the pencil point at 2 and pivot the paper as before. Continue until

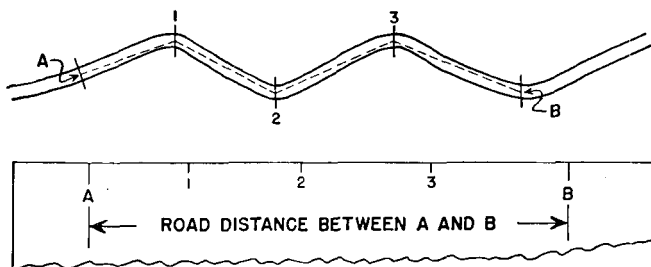

FIGURE 7.—Measuring distance along winding road.

the long line lies along course 3-B. Mark the position of B by a tick on the long line. Measure the distance along the graphic scale as described above.

■ 10. TIME.—*a. Conversion of march time to distance*.—It will often be necessary to determine the distance a column can march in a given period of time. The distance is the product of the time in hours multiplied by the hourly rate of march. For example, a motorized unit averaging 30 miles per hour can cover $4 \times 30 = 120$ miles in 4 hours. This whole distance is plotted on the edge of a strip of paper by means of the mile graphic scale. Then the distance may be laid off along the straight portions of the road by marking ticks for each change of direction along the measured portion of the strip of paper, reversing the methods shown in para-

graph 9. Thus the position of the head of the column at the end of any given time may be determined.

b. Conversion of distance to march time.—To determine how long it will take to move troops from one point to another, the distance between the two points is taken as above from any suitable map. The distance divided by the hourly rate of march gives the time required to move the troops. The habitual daytime rate of march for foot troops, making allowance for customary halts, averages $2\frac{1}{2}$ miles per hour. For example, the time to march foot troops a distance found to be 15 miles on the map is 15 divided by 2.5, or 6 hours.

SECTION IV

DIRECTION AND AZIMUTH

■ 11. NEED FOR DIRECTION.—To locate objects both direction and distance are needed. For example, an object can be located by telling in what direction and how far away it is from a given point. Most persons are familiar with the established geographic terms north, south, east, and west. These are the directions that are indicated by the common military watch compass shown in figure 8.

■ 12. UNIT OF ANGULAR MEASURE.—*a. General.*—Angles may be measured in degrees, minutes and seconds, or in mils (see fig. 9). Normally only personnel in artillery or heavy weapons units have to use the mil since their fire-control instruments are generally graduated in mils rather than degrees. Other personnel usually use degrees, minutes, and seconds.

b. Angles.—(1) *In degrees, minutes, and seconds.*—If the circumference of a circle is divided into 360 equal parts by lines drawn from the center to the circumference, the angle at the center between any two adjacent lines is one degree. There are 60 minutes in a degree, and 60 seconds in a minute. Thus—

60'' (seconds) = 1' (minute).

60' (minutes) = 1° (degree).

360° (degrees) = 1 circle or a circumference.

Angles are written as $137^{\circ}45'23''$.

(2) *In mils.*—If the circumference of a circle is divided into 6,400 equal parts by lines from the center to the circum-

ference, the angle at the center between any two adjacent lines is 1 mil. Thus an angle would be written in mils as 1,327 mils.

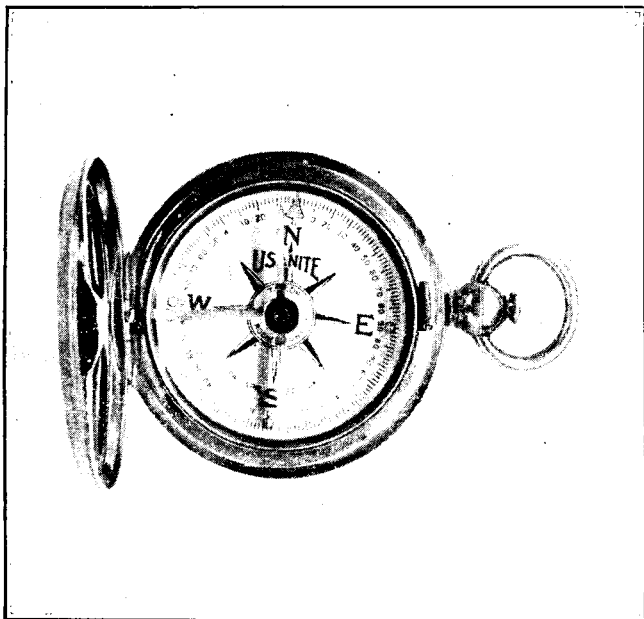

FIGURE 8.—Watch compass.

c. Relation between degrees and mils.—Degrees may be changed to mils or mils to degrees by using the following simple conversion factors:

$$360^{\circ} = 6,400 \text{ mils}$$

$$1^{\circ} = \frac{6,400}{360} = 17.8 \text{ mils (or 18 approximately)}$$

$$\text{Hence } 10^{\circ} = 10 \times 17.8 = 178 \text{ mils (or 180 approximately)}$$

$$1 \text{ mil} = \frac{360}{6,400} = .056^{\circ} \text{ (or } 3.4' \text{ approximately)}$$

$$\text{Hence } 100 \text{ mils} = 100 \times .056 = 5.6^{\circ} \text{ or } 5^{\circ} 36'$$

■ 13. BASE DIRECTION.—For military purposes direction from one point to another is always expressed in terms of an angle at the initial point between the line joining the points and

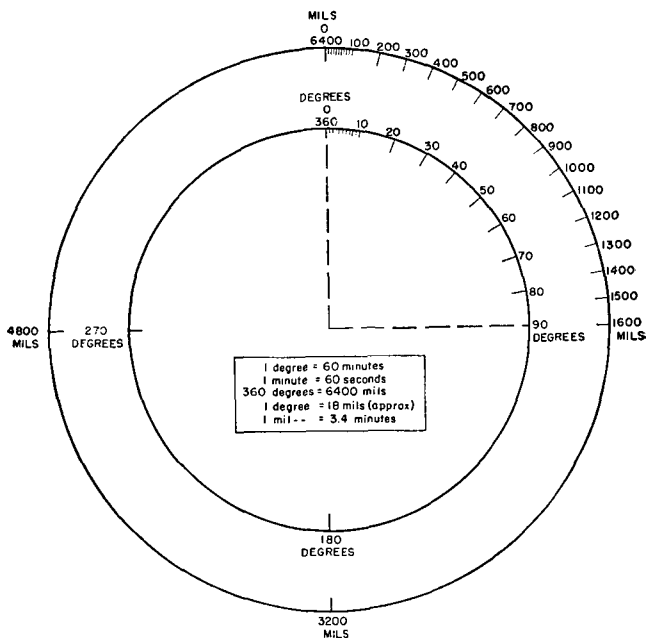
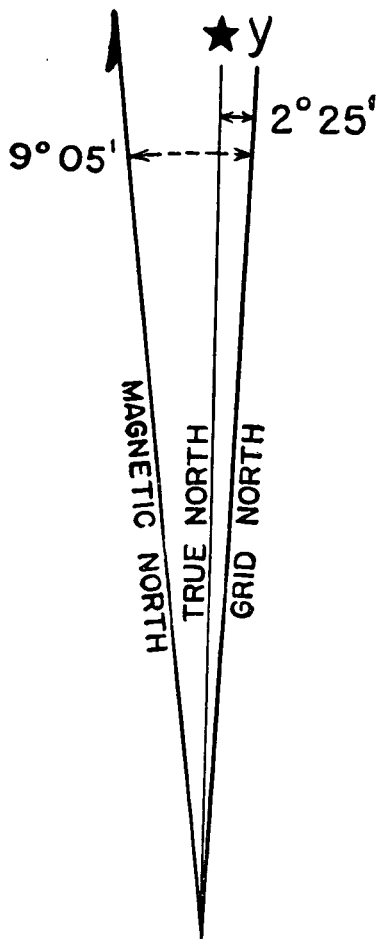

FIGURE 9.—Units of measurement.

some fixed or easily established base direction line. There are three base directions from which other directions are commonly measured, namely, true north, magnetic north, and grid north, shown on maps by a star, half arrowhead, and *y*, respectively (fig. 10).

a. True north.—The direction to the true north pole. It is used in surveying or other permanent work where great accuracy is required. Where meridian or longitude lines are shown on maps they represent true north and south directions. For ordinary military map reading in the field, true



APPROXIMATE MEAN DECLINATION 1935
ANNUAL MAGNETIC CHANGE 3' INCREASE

FIGURE 10.—Declination.

north normally will be used only as base from which declinations are computed. It normally is not used as a direction in marching by compass or orienting a map. The true north line on the declination shown in figure 10 has been purposely made very light to emphasize its relative unimportance in general map reading use.

b. Magnetic north.—The direction of the north magnetic pole. It is indicated by the N (north seeking) end of all compass needles. It is ordinarily used for field work because it can be found directly by means of the common compass.

c. Grid north.—The direction of the vertical grid lines (north-south grid lines) usually found on military maps. On maps with military grid, determination of directions from grid north is convenient because grid lines are located at frequent intervals.

■ 14. DECLINATION.—Declination is the difference in direction between true north and magnetic north or between true north and grid north. There are therefore two declinations, magnetic and grid; in figure 10, magnetic declination is $9^{\circ}05' - 2^{\circ}25' = 6^{\circ}40'$ and grid declination is $2^{\circ}25'$.

a. Magnetic.—Magnetic declination is the difference between true north and magnetic north. In some localities the compass needle points east of true north; in these localities its magnetic declination is east. In some localities the compass needle points west of true north and in these localities the magnetic declination is west. In some instances, true north and magnetic north are the same, in which case the magnetic declination is zero. The magnetic declination may vary annually by small amounts. On military maps there is usually shown in the margin a diagram of the declination with the annual change, if any. For example, in figure 10 the magnetic declination is $6^{\circ}40'$ west as of 1935, and the annual change is $3'$ increase. In 1940 (5 years later) the magnetic declination is $6^{\circ}40'$ plus $5 \times 3'$ or $6^{\circ}55'$.

b. Grid.—Grid declination is the fixed difference in direction between true north and grid north. This declination is always the same on any given map. Grid declination reaches a maximum of 3° either east or west of true north depending on the locality. On military maps it is shown on the same

diagram as the magnetic declination. Thus in figure 10 the grid declination is $2^{\circ}25'$ east and there is no annual variation.

c. Use.—Figure 11 illustrates three positions of grid, magnetic, and true north. There are other possible positions. In ordinary map reading the difference in direction between grid north and magnetic north is desired rather than their difference from true north. This can be found in the three examples as follows: in figure 11① the difference between mag-

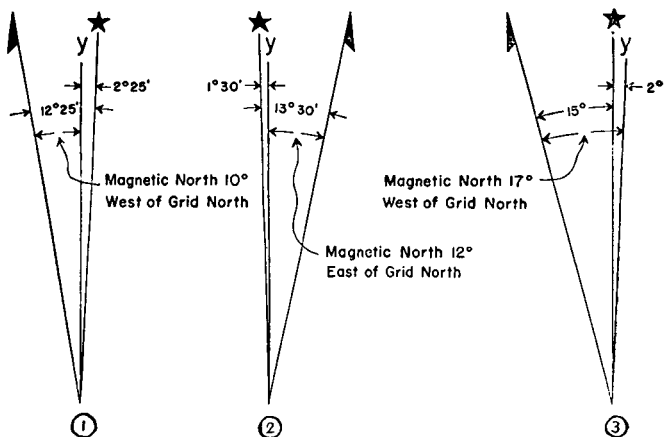

FIGURE 11.—Determining difference in direction between grid and magnetic north.

netic and grid declination is seen by inspection to be $10^{\circ}0'$ ($12^{\circ}25' - 2^{\circ}25'$). In ② it is $12^{\circ}0'$ ($13^{\circ}30' - 1^{\circ}30'$). In ③ it is $17^{\circ}0'$ ($15^{\circ}0' + 2^{\circ}0'$). In the other possible positions of these lines, the declination is determined in a similar manner. When starting to use a map, determine the angle between magnetic north and grid north as described above. Write this down on the map and figure all azimuths on this basis.

■ 15. AZIMUTH.—In describing the position of one point on a map or in the field with reference to some other point, we use a standard system of measuring direction. In military work the azimuth method has been adopted for the purpose. Military azimuths are generally measured clockwise from mag-

netic, true, or grid north. Thus there are three kinds of azimuth for any given line: magnetic, true, and grid.

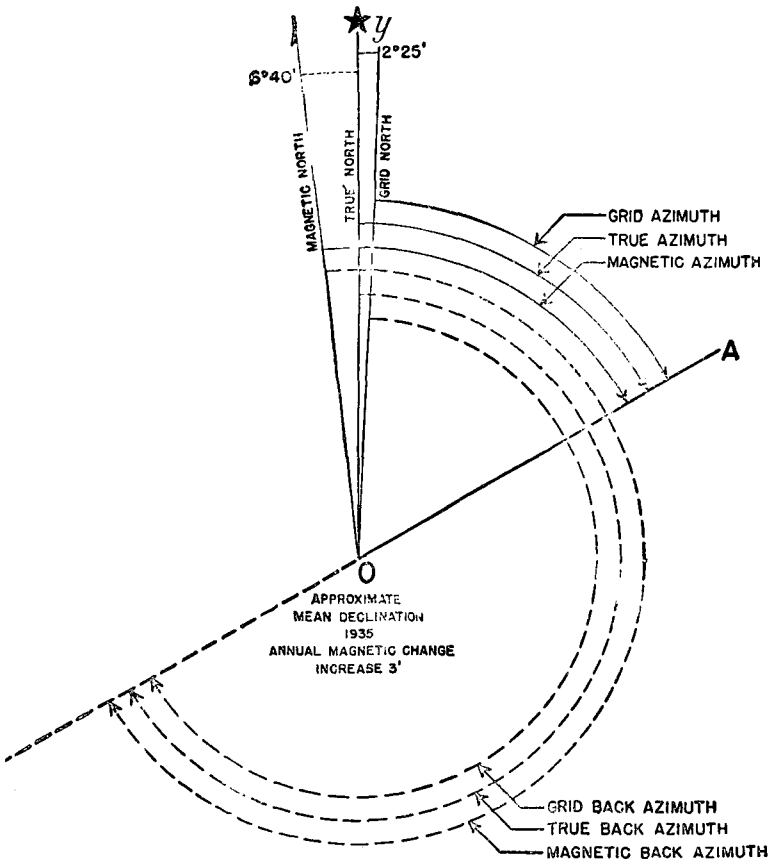

FIGURE 12.—Example of relationship between three base directions on a map, showing corresponding azimuths and back azimuths of line OA.

a. Magnetic.—The magnetic azimuth of any given line is the angle measured clockwise from magnetic north to the given line (fig. 12).

b. True.—The true azimuth of any given line is the angle measured clockwise from true north to the given line (fig. 12).

c. Grid.—The grid azimuth of any given line is the angle measured clockwise from grid north to the given line (fig. 12).

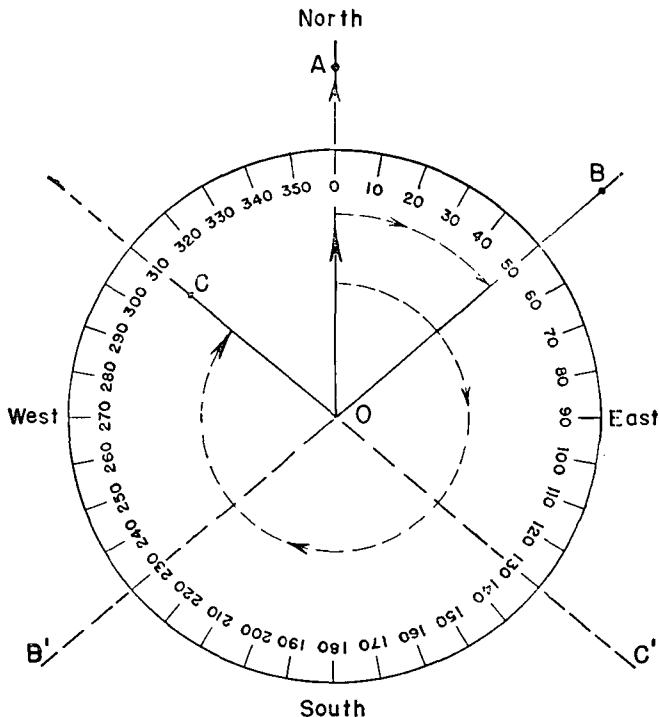
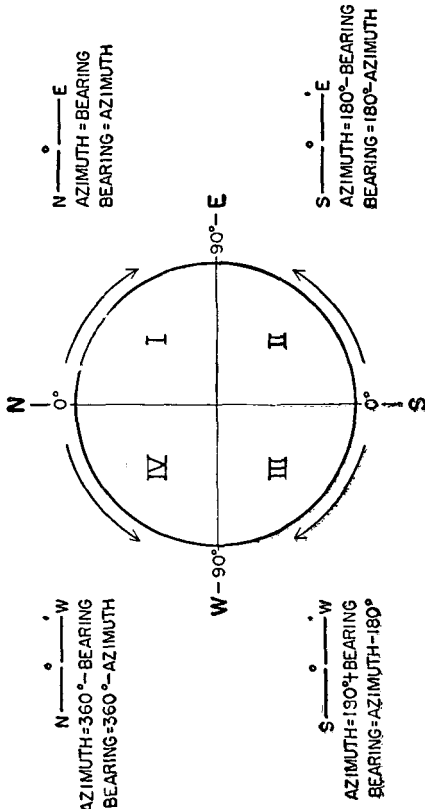

FIGURE 13.—Azimuth circle.

d. Back.—Depending on the direction in which a line extends, its azimuth may be expressed in two ways, either as forward azimuth or as back azimuth. The back azimuth of a line is its forward azimuth plus 180° . (If the sum is greater than 360° , subtract 180° from the forward azimuth to secure the back azimuth.) For example, in figure 13 the azimuth of the line extending in the direction O to B would be 50° .

The azimuth of the same line extending in the direction **B** to **O** is 50° plus 180° or 230° , which is the same as the azimuth of **OB'**. Similarly the forward azimuth of the line extending from **O** to **C** is 310° . Since the sum of the forward azimuth plus 180° is greater than 360° , the back azimuth or the azimuth of the line extending from **C** to **O** is 130° ($310^\circ - 180^\circ$), which is the same as the azimuth of **OC'**. Back azimuths may be magnetic, grid, or true the same as forward azimuths and the proper designation should be included in the expression as, "Azimuth **OC'** 130° (magnetic)."



Arrows indicate the direction of measurement of the bearings in each quadrant from 0° to 90° :

Azimuths are measured in a clockwise direction from 0° (north point) to 360° .

FIGURE 14.—Diagram indicating relation between bearing and azimuth.

■ 16. BEARING.—The new lensatic compass gives direction by magnetic azimuths. Watch compasses, many of which are still in use, give directions by bearings. A bearing of a

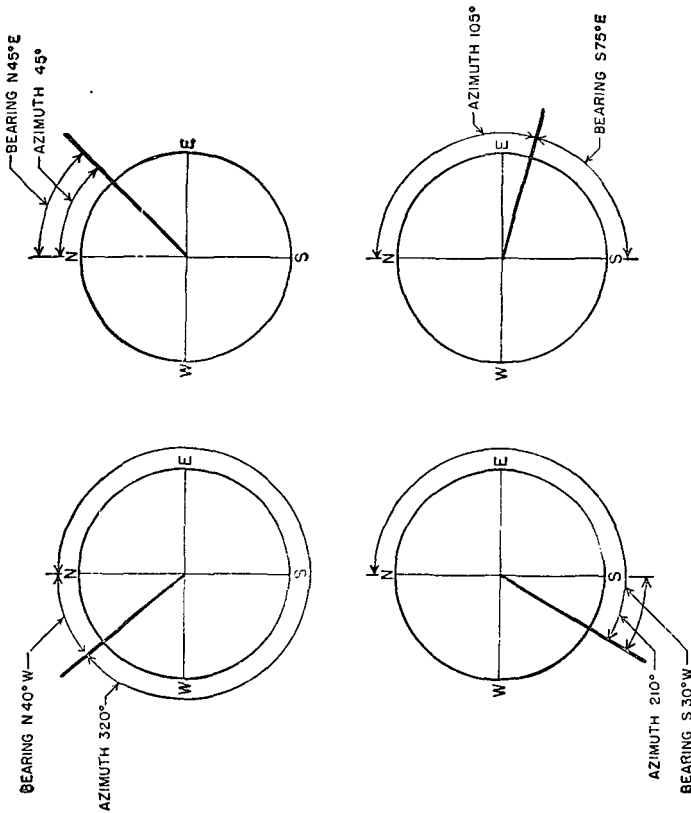

Figure 15.—Typical direction expressed as azimuth and as bearing.

given line is an angle and direction which the line makes with respect to a north or south direction line. Bearings are stated by quadrants (quarters of circles) and never exceed 90°. Figure 14 shows how bearings are measured and

indicates relationship between bearings and azimuths. Figure 15 illustrates the expression of a typical direction in each quadrant both as an azimuth and a bearing.

■ 17. PROTRACTOR.—Angles of azimuth or bearing are measured or laid off on a map by means of an instrument called a

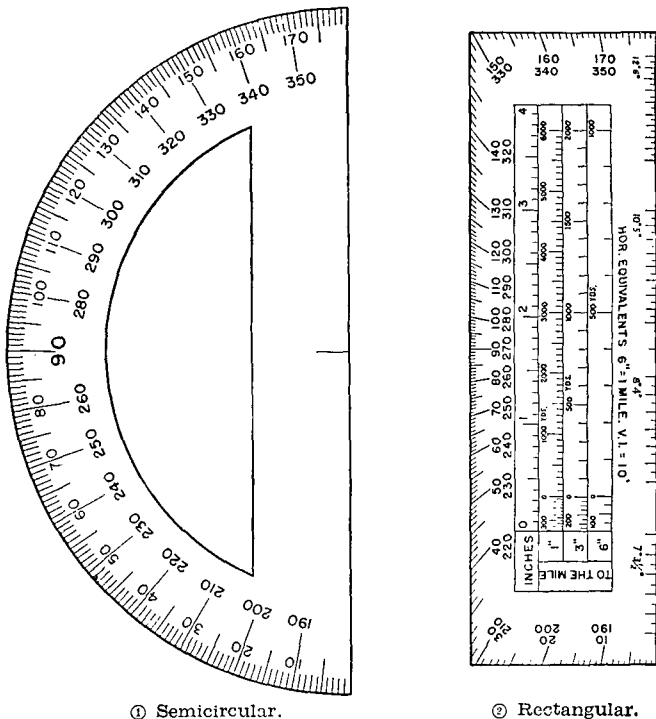

FIGURE 16.—Military protractors.

protractor. Figure 16 illustrates two types; the semicircular type is the more common. Each represents one half of an azimuth circle. In the figure it will be noted that two scales are shown, one reading from 0° to 180° and one from 180° to 360°, used for reading azimuths greater than 180°.

■ 18. TO MEASURE AZIMUTH OF ANY LINE ON MAP (fig. 17).—
a. Required, to find the grid azimuth of the line from the CR (crossroads) at A to the house at B. Extend the line AB until it intersects the 349 grid line. Lay a protractor on the map with its center at this intersection and the straight portion lying along the 349 grid line. Read the grid azimuth of AB. This azimuth is seen to be 137° .

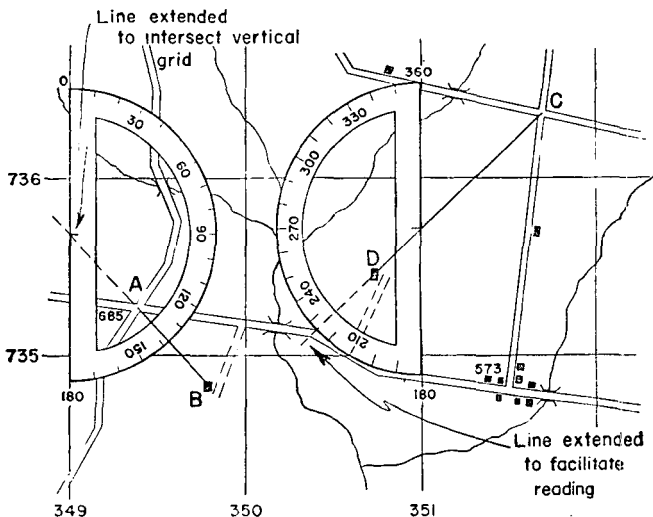

FIGURE 17.—Using protractor to measure map azimuth. Azimuth of line AB is 137° ; of CD is 226° .

b. Required, to find the grid azimuth of the line from the CR at C to house at D. Extend the line CD a sufficient distance so that it will extend beyond the edge of the protractor. Lay the protractor on the map with its center at the intersection of CD with the 351 grid line and the straight portion lying along the 351 grid line. Since the azimuth of the line is greater than 180° , the scale reading from 180° to 360° will be used to determine the azimuth of CD. This azimuth is 226° .

■ 19. TO PLOT ON MAP LINE WITH GIVEN AZIMUTH (fig. 18).— Required, to plot from CR (crossroads) 685 a line with a grid azimuth of 75° . Construct a line through the CR parallel to the north-south grid. Lay a protractor on the map with its base on the line and its center at the CR. Plot the point P at the 75° reading on the outer scale of the protractor. Remove the protractor and draw a line from the CR through P.

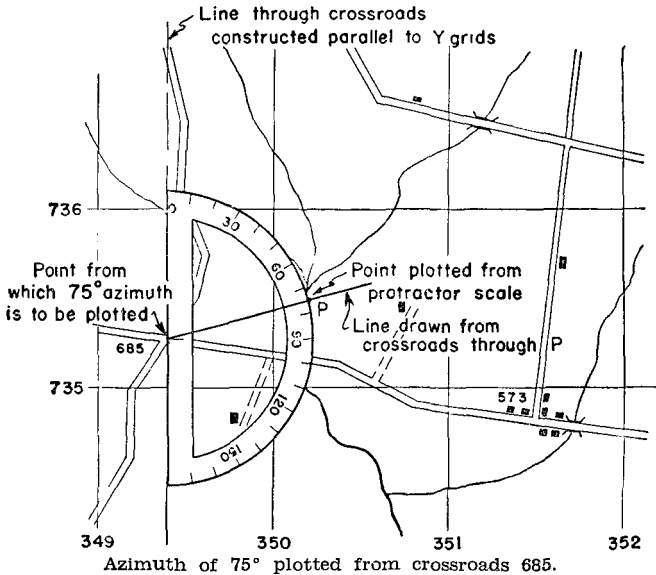
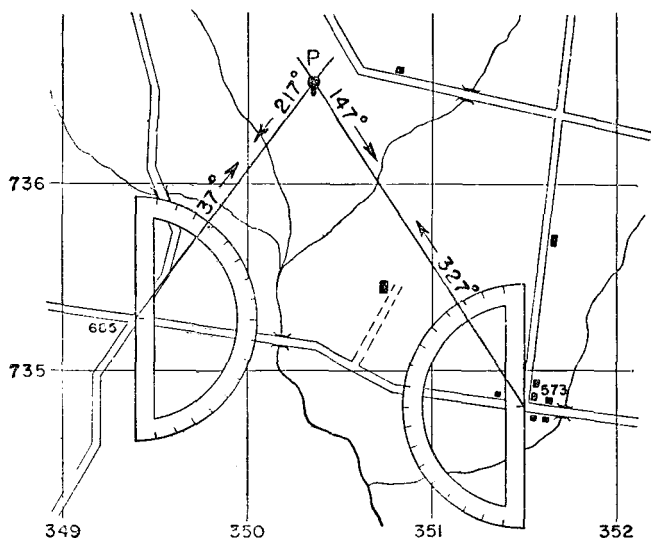

FIGURE 18.—Plotting azimuths.

■ 20. LOCATING POINT BY INTERSECTION AND RESECTION.—*a. General.*—Sometimes it will be necessary for patrol leaders or other military personnel to determine map position of points or objects located either in enemy or other inaccessible territory. Also it may be necessary to find their own map position from inaccessible but visible points that are shown on the map. Figure 19 shows how both these operations can be accomplished.

b. Intersection.—Required, to find map position of an enemy gun that has been spotted at the point P (fig. 19) on the ground. Both CR 685 and RJ 573 are in our territory and the enemy gun is visible from both of these points. By means of a prismatic compass, the magnetic azimuth was taken from CR 685 to the gun at P. Reduced to grid azimuth



Where azimuths from road junctions to gun are known, their plotting gives location of the gun. Where azimuths from gun to road junctions are known, they can be converted to back azimuth and gun position plotted as before.

FIGURE 19.—Locating points by intersection and resection.

muth, it was 37° . This grid azimuth was then plotted from CR 685 as shown. Likewise, the magnetic azimuth from RJ 573 to P was taken and reduced to grid azimuth. The grid azimuth was 327° . This azimuth was then plotted from RJ 573. The intersection of these plotted azimuths gives the map position of the gun at P which can be checked by additional similar observations. Observation points should be selected such that the plotted azimuths cross at as near

a 90° angle as possible so that the point of intersection is definite.

c. *Resection* (fig. 19).—(1) Required, someone at P to find map position of gun at P. This gun is in our territory but no landmarks or other easily identified terrain features are close enough to permit location from these points. However, CR 685 and RJ 573 are visible from P and are also shown on the map. The azimuths from P are read to both road intersections. These azimuths are then converted to grid back azimuths and plotted as before, giving the map position of the gun.

(2) Note that in using these two systems no measurement of distance is required. Location of position is determined merely by reading two angles and plotting two lines.

SECTION V

LOCATION BY COORDINATES

■ 21. **GENERAL.**—In military operations it is frequently necessary to refer to points on the ground or terrain features in short, convenient, unmistakable terms. The easiest way to accomplish this is to designate the point when given on a map by its name or number. Military maps often show names or numbers of all important locally known features. Hills, road junctions, and crossroads are often given numbers, usually in terms of their elevation in feet above sea level, thus serving the dual purpose of designating the feature and also giving its elevation. But it is not possible to number or name all features of military value on a map. Also it is often difficult to find such points on the map even when they are named or numbered. Thus some simple method or system for describing the position of a point or a place on a map is essential for quick and accurate identification. The use of coordinates has been adopted to serve this purpose. There are several types of coordinate systems but the polar and the military grid are the two types most used and ones with which all officers and enlisted men must be familiar.

■ 22. **POLAR COORDINATES.**—This system consists of locating a feature by giving its distance and direction from a nearby

landmark, the name and location of which is known or shown on the map. Polar coordinates are commonly used in designating points located with a compass in the field and in designating positions on maps not equipped with the military

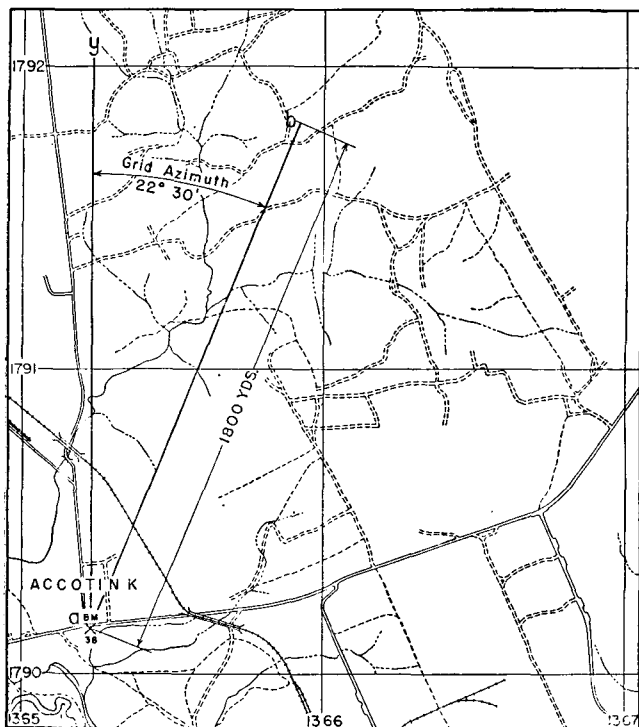

FIGURE 20.—Polar coordinates of b from BM 38, Accotink (village), distance 1,800 yards, on grid azimuth 22°30'.

grid. They are also frequently used in connection with ordinary field sketches. The landmark and selected direction must be clearly described in addition to stating the distance and angle. Polar coordinates are commonly used by reconnaissance patrols sent out to locate enemy installations. The

information brought or sent back by such patrols is usually in the form of a sketch. This sketch gives the distance and a magnetic azimuth to the enemy locations from point of observation of the patrol. Distance is estimated and azimuth read with the compass carried by the patrol leader. From these sketches it is possible to plot the position of these enemy installations on a map. Magnetic azimuths are changed to grid azimuths as stated in paragraph 15, and distance plotted along this azimuth line from the stated point of observation of the patrol. For example (see fig. 20), a patrol sends back information that an enemy position is located at b, an estimated distance of 1,800 yards on a magnetic azimuth of $31^{\circ}30'$ from BM 38 located in Accotink village. On this map, the magnetic north being greater by 9° than grid north, company headquarters, on receiving this information, changes the magnetic azimuth of $31^{\circ}30'$ to a grid azimuth of $22^{\circ}30'$. It then can plot the enemy position (point b) at a distance of 1,800 yards to scale from BM 38 in Accotink village along this grid azimuth as indicated in figure 20.

■ 23. MILITARY GRID.—*a. General.*—To make the reading of military maps easy, grids are printed on the map. The grid is simply a set of numbered north and south lines showing distance in thousands of yards east of the origin, and a set of numbered east and west lines showing distances in thousands of yards north of the same reference point. On a large-scale map (for example, 1:20,000 (par. 5)) these lines are 1,000 yards apart. On the medium-scale map (par. 5) the lines are 5,000 yards apart.

b. Location by grid coordinates.—Points are designated by coordinates simply by the intersection of the north-south grid lines (vertical lines) with the east-west grid lines (horizontal lines). Thus, in figure 21, location of the point A is indicated by the intersection of the 198 grid line and 262 grid line; the coordinates of the point therefore are (198-262). Note that distance east of origin is called the X-coordinate and is read first; and that distance north of origin is called the Y-coordinate and is read last. Beginners often make the error of reading the wrong coordinate first. One way to avoid this is to remember the key phrase "READ-

RIGHT-UP." It often may be necessary to designate points which do not fall at the intersection of grid lines. For example, it is required to find the coordinates of point B in figure 21. If it is assumed that the sides of the grid square are further subdivided into 10 equal parts, it is seen that the point B is 8 of these parts east and 7 of the parts north of the southwest corner of the square in which B is located. The coordinates of the point B are therefore written (197.8-263.7). Often sufficiently close determination can be made by estima-

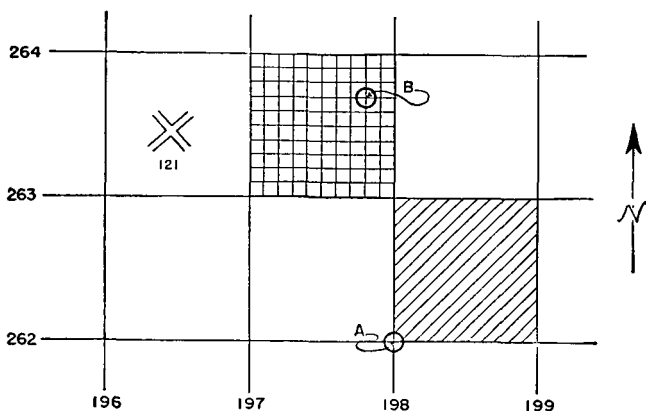

FIGURE 21.—Coordinates.

tion. For example, CR (crossroads) 121 could be located by inspection at (196.4-263.4). Since on all commonly used large-scale maps the grid square measures 1,000 yards on a side, a reading to tenths (one decimal place) gives a location to the nearest 100 yards. A reading of hundredths (two decimal places) gives an accuracy within 10 yards. When the grid numbers have more than two digits, it is customary to drop off all but the last two digits. Thus, the coordinates of point B above may be written (97.8-63.7), or if greater accuracy is desired (97.80-63.70).

c. Location by grid squares.—When a point is easily identified such as a numbered cross road or a town, it is necessary merely to refer to the southwest corner of the grid square in

which it is located. For example, in figure 21 crossroads 121 could be designated as CR 121 (96-63).

■ 24. COORDINATE SCALE.—*a. General.*—In paragraph 23*b*, the coordinates of point B were found by subdividing each side of the square (197-263) into 10 parts. This operation is used

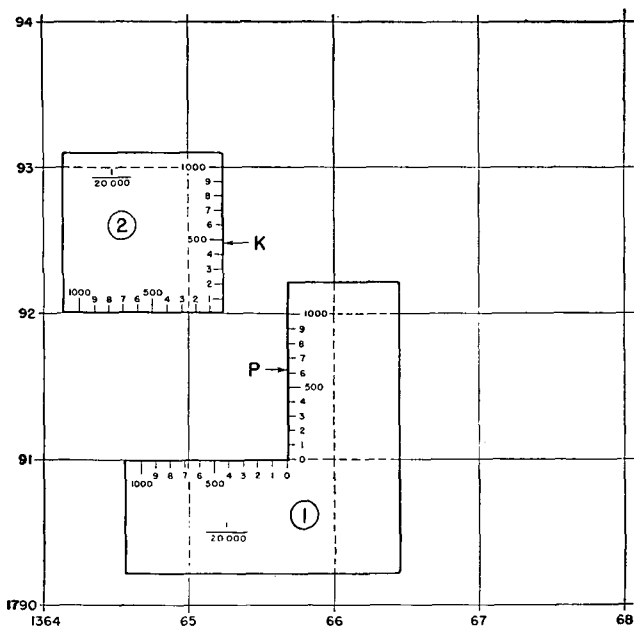

FIGURE 22.—Plotting point with coordinate scale.

only for explanation and is too long and tedious for normal use. A grid coordinate scale or card as shown in ① and ②, figure 22, permits finding these coordinates rapidly and easily. These cards may be made of cardboard, metal, or celluloid. For large-scale maps having grids 1,000 yards apart, lay off on the interior edges 1,000 yards to the scale of the map. Beginning at the vertex divide each 1,000 yards into 10 equal parts. This may be done by means of the graphical scale

printed on the map. For medium-scale maps having grids 5,000 yards apart, lay off on the inner edges 5,000 yards to the scale of the map, and subdivide each 1,000 yard division into

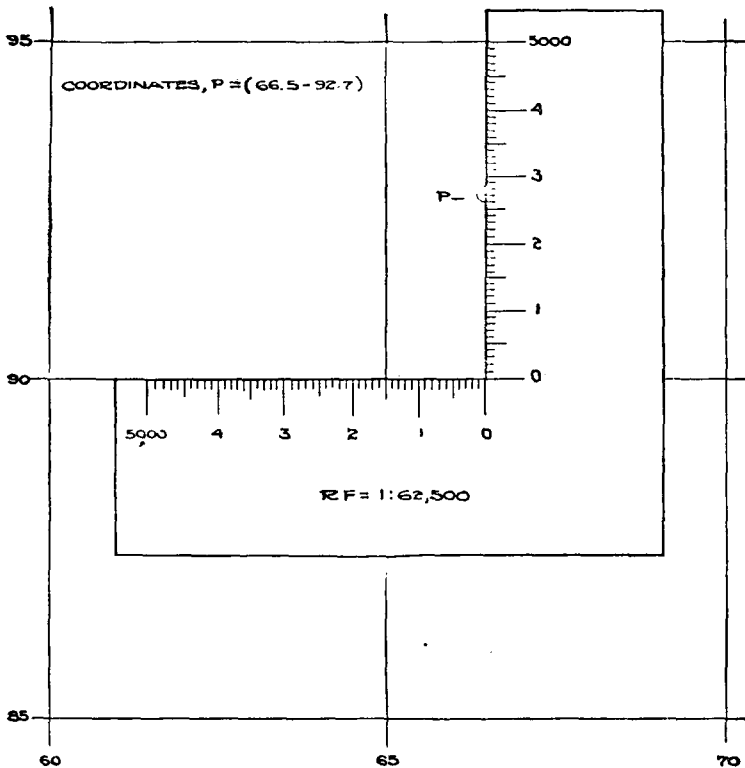

FIGURE 23.—To read grid coordinates of point on map (1:62,500) with 5,000-yard grid by means of coordinate scale. (Not reproduced to scale.)

10 equal parts as described above (fig. 23). The L-shaped type is more convenient to use. However, the rectangular type (① and ②, fig. 22) may be readily improvised by use of any square piece of cardboard or heavy paper.

b. To read coordinates of any point on map using coordinate scale.—Required, to find coordinates of point P (fig. 22). First identify the square in which P lies and write the coordinates of the lower left (southwest) corner of the square thus (1,365-1,791) or, dropping off the first two digits as described in paragraph 23b, it could be written (65-91). Now place the coordinate scale with its horizontal (east-west) edge on the 1,791 grid line. Keeping this edge on the 1,791 grid line, slide the scale along until its north-south scale passes through the point P. The decimal portion of the X-coordinate is read on the horizontal (east-west) scale, where it is cut by the west boundary of the square (in this case the 1,365 grid line). The decimal portion of the Y-coordinate is read on the vertical (north-south) scale, at the point P. These readings are then filled in at the proper places after the coordinates already written down. Reading to the nearest 100 yards, the coordinates of P are (1,365.7-1,791.6) or (65.7-91.6). Reading to the nearest 10 yards the coordinates are (65.68-91.62). The coordinates of K are (65.25-92.48). Similarly for the medium scale map shown in figure 23 the coordinates of the point P are (66.5-92.7).

c. To plot on a map any point whose coordinates are given.—This process is the reverse of determining the coordinates of a point. For example, in figure 22 let us assume that it is required to plot the position of the point P whose coordinates are (1,365.68-1,791.62). Place the coordinate scale on the map as shown in position ① in figure 22. The position of P can be marked at once with a pin or sharp pencil.

SECTION VI

ELEVATION AND RELIEF

■ 25. GENERAL.—*a. Ground form and elevation.*—Up to this point the map has been regarded as a representation of a flat surface and only the horizontal position of features indicated thereon has been considered. A map to be of the greatest practical value must convey to the user a definite impression of ground forms (hills, ridges, and valleys) known as relief. This brings up the important subject of elevations.

By elevation is meant the vertical distance of any specified point on the earth's surface above a selected reference plane, which for most maps is mean sea level.

b. *Means of representing relief and elevation.*—Since a map is a plane surface, some type of conventional sign must be used in order to represent relief and elevation. On most modern topographical maps, this is accomplished by the use of contours. Other methods such as hachures (par. 28) and

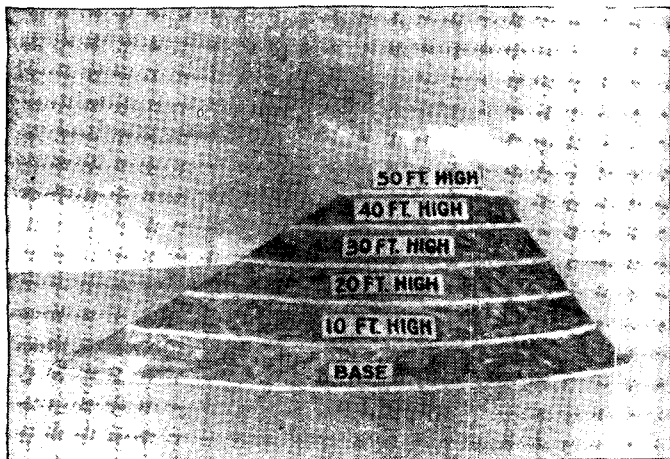

FIGURE 24.—Side view of hill.

hill and valley shading are used but contouring is the most common and practical method.

■ 26. CONTOURS.—a. *General.*—Contours are the conventional signs drawn on a map to show the different ground forms. After practice with contours the map reader cannot only visualize shapes of hills, mountains, and valleys, but can also find elevation of points and determine slope and visibility along given lines. A contour is a line drawn on a map which represents an imaginary line on the ground all points of which are at the same elevation. Figure 24 represents a hill in the middle of the ocean. The seashore line itself would be the base or zero contour. If the sea should rise 10 feet

the new seashore line would mark the 10-foot contour. Similarly the next higher contour line would be marked for each rise in elevation of 10 feet. Figure 24 shows the successive increases in sea level which indicate contours. Figure 25 gives an oblique view of this same hill. From directly above, the hill would appear as in figure 26. Figures 24, 25, and 26 are photographs. Consequently, wiping out the picture of the hill itself, it would appear on a map as in figure 27 when indicated by contours alone.

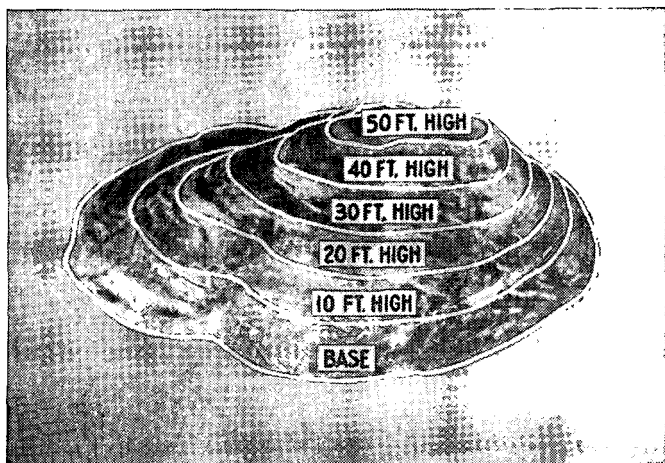

FIGURE 25.—Oblique view of hill.

b. Characteristics.—Figure 28 represents a number of more common ground forms as they are shown by contours. Looking at this figure it should be noted that—

- (1) Contours have a characteristic wavy appearance.
- (2) Elevation of contours above the reference plane (mean sea level) is shown by numbers usually in feet.
- (3) At A, B, and C are contours which are closed curves, indicating either hilltops or depressions. Since the contour numbers increase as these points are approached it is apparent that A, B, and C are actually on hilltops.

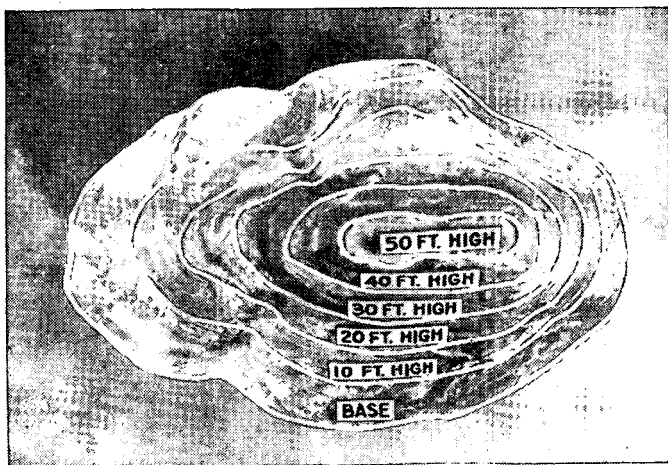

FIGURE 26.—Top view of hill.

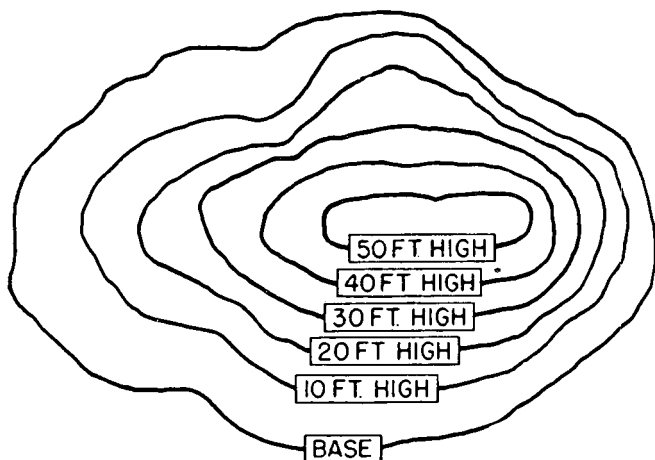

FIGURE 27.—Hill shown by contours.

(4) Contour at A, being nearly circular, indicates the top of a peak or knob, whereas the elongated contour at C indicates the crest of a sharp ridge.

(5) Though all contours are closed curves, most of those shown do not close within the limits of the map sheet. The 200-foot contour runs off the sheet at D-D and closes just

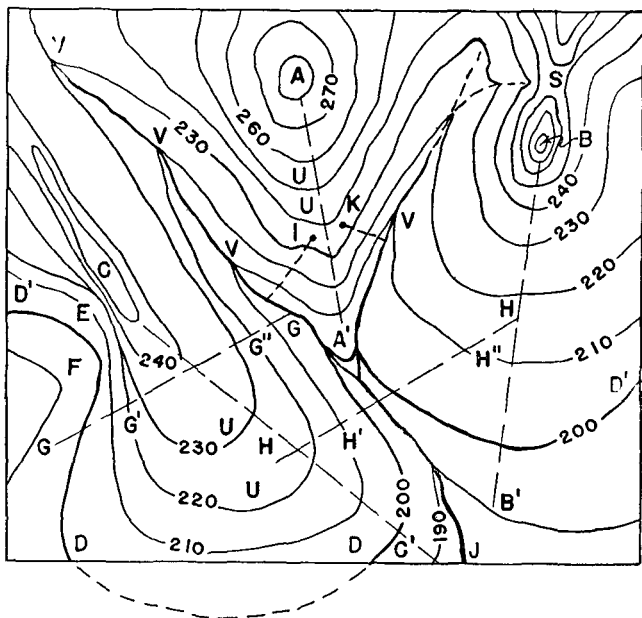

FIGURE 28.—Characteristics of contours.

outside, as indicated by the broken line. It runs off again at D'-D' and closes beyond limits of the sheet.

(6) On the line AA' there is a uniform slope. This is indicated by the equally spaced contours. On the line BB' there is a concave (sway-back) slope since the contours are close together at the top and farther apart at the bottom. On the line CC' there is a convex (humpback) slope. At B there is a steep slope while at B' there is a gentle slope.

The representation of these slopes by means of profiles is further illustrated in figure 29. (For construction of profiles see paragraph 31.)

(7) Contours do not touch each other except at E, which indicates a vertical cliff.

(8) At the points marked V is seen the characteristic V-shape of valley or streamline contours, and at those points marked U, the U-shape of ridge contours. The closed ends of the V's point upstream and those of the U's downhill.

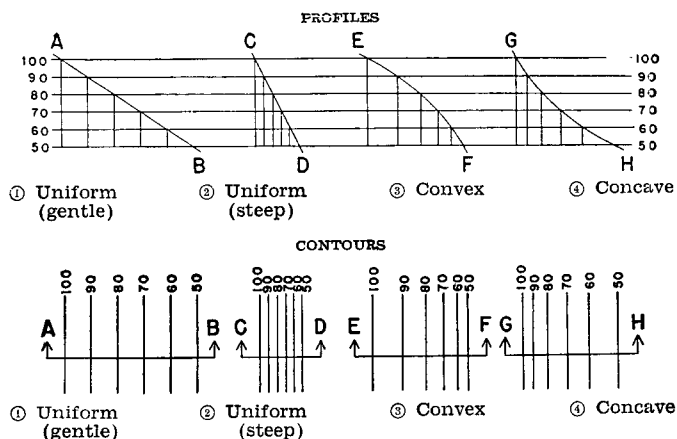

FIGURE 29.—Representation of slope by contours.

(9) At A' is shown the characteristic M-shape appearance of the contour at a Y-stream junction.

(10) Rain falling at I runs down the slope normal to the contours, entering the drainage line near G, and ultimately leaving the area by the main stream at J. The line of the spur AA' is the divide between the two tributary streams. Rain falling at K, just east of the divide, flows into the eastern tributary. The divide between any two adjacent valleys is easily traced out.

(11) Point S is a saddle, a depression or low point in a ridge or line of hills. Note the characteristic shape of the contours. Saddles occur frequently.

(12) Adjacent contours in a water-worn terrain resemble each other. This is the same as saying that changes in the form of the ground are gradual. This characteristic may be noted at many places, as on the ridge lines at AA' and BB'.

c. Summary.—Briefly summarized, contour characteristics previously discussed and illustrated are—

(1) A contour is a line on a map joining points of equal elevation.

(2) Contours are spaced at uniform vertical intervals.

(3) A small closed contour indicates a hilltop or a depression when so marked by the conventional sign (see fig. 3).

(4) Every contour is a continuous closed curve, on or off the map.

(5) Spacing of contours indicates steepness of slopes. This spacing also indicates nature of slope, whether uniform, concave, or convex.

(6) Contours do not touch or cross each other, except in the unusual case of cliffs.

(7) Valleys are usually characterized by V-shaped contours, and ridges by U-shaped contours.

(8) Adjacent contours resemble each other.

d. Logical.—(1) Figure 30 shows the method by which a map maker draws contours on a map when he is given the drainage net and the elevations for certain critical points. Drawing of logical contours is valuable practice in gaining ability to visualize ground forms shown by contours on topographic maps.

(2) The information shown in figure 30① has been obtained by a field survey or other means. This information consists of the courses of the stream lines and elevations of selected critical points and forms the framework upon which the contour map is drawn. Consider the stream line in the lower right portion of ② running from elevation 97 to elevation 133. Elevations 100, 110, 120, and 130 are marked on this stream line by interpolation. V-marks pointing upstream are used to mark such elevations on a stream line. All other stream lines are treated in a similar manner. Contour locations are marked on the ridge lines in a similar manner, except that straight marks normal to the ridge line are used.

Marks of equal elevation are then joined producing contours as shown in ③.

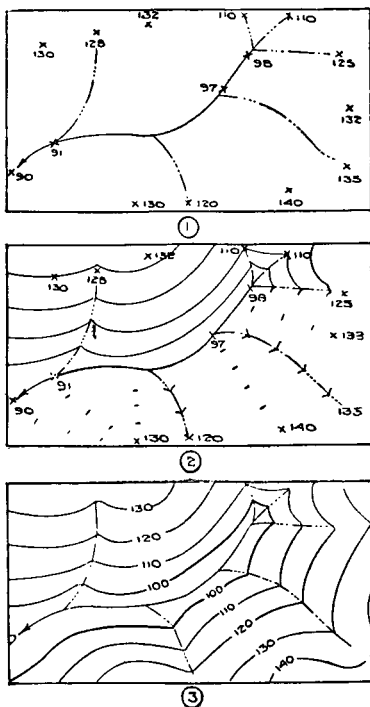

FIGURE 30.—Method of drawing contours by interpolation on drainage net where elevations are given.

■ 27. DETERMINING ELEVATION FROM CONTOURS.—Often the map reader will be concerned with some point on a map which may happen to be located between two contours, and it will be necessary to know the elevation of the point in question. If any point such as B (fig. 31) lies directly upon a contour, its elevation is of course that marked on the contour, or 580 feet in this case. But suppose the point X is not directly upon a contour. It lies between contours 580 and 590. Its

elevation is therefore something between these two figures. If a line is drawn through X perpendicular to the adjacent contours, it will cross them at A and B. Then the elevation of A is evidently 590 feet and the elevation of B 580, because these points lie upon the contours so marked. Assuming the ground falls uniformly from A to B, without making any measurement of the distance BX, it can be judged by eye that it is a little more than half and a little less than two-thirds of the distance AB. It may be said without any great

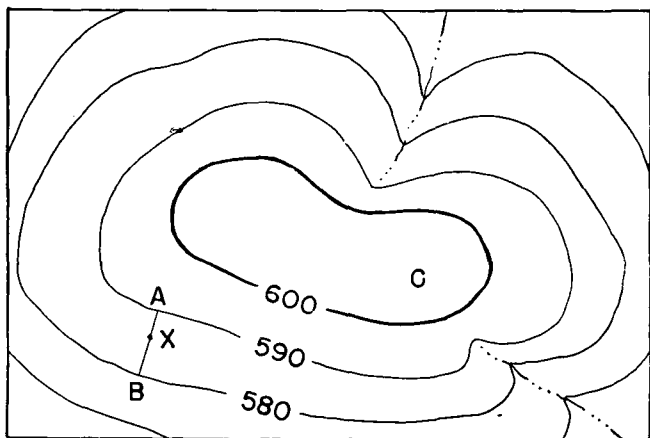

FIGURE 31.—Determining elevation from contours.

error that it is 0.6 of AB. The difference of elevation of A and B is 10 feet. Hence the elevation of X is 580 plus 0.6 of 10 feet or 586 feet, giving an error probably less than 1 foot. This determination is close enough for the map reader. It is not necessary to draw such a line as AB or to measure a distance such as BX. If the point Y is taken it can be said by merely looking at it that its elevation is 588 feet. In case the point in question lies on the top of a hill such as C, only an approximation is possible. The elevation of C is greater than 600 but not as much as 610 since the 610 contour is not shown. Often the exact elevation of the highest points on hills will be given.

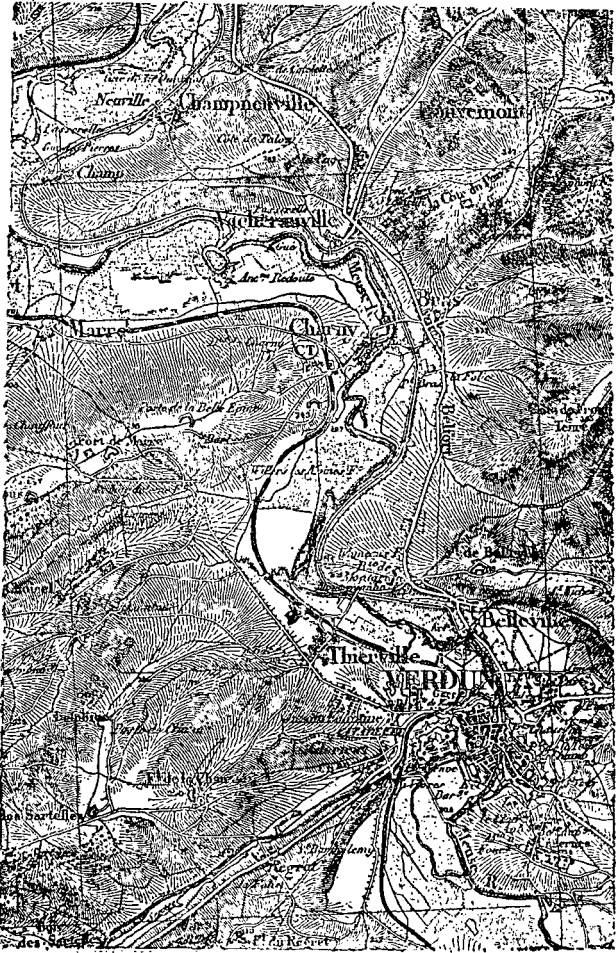

FIGURE 32.—Hachure map,

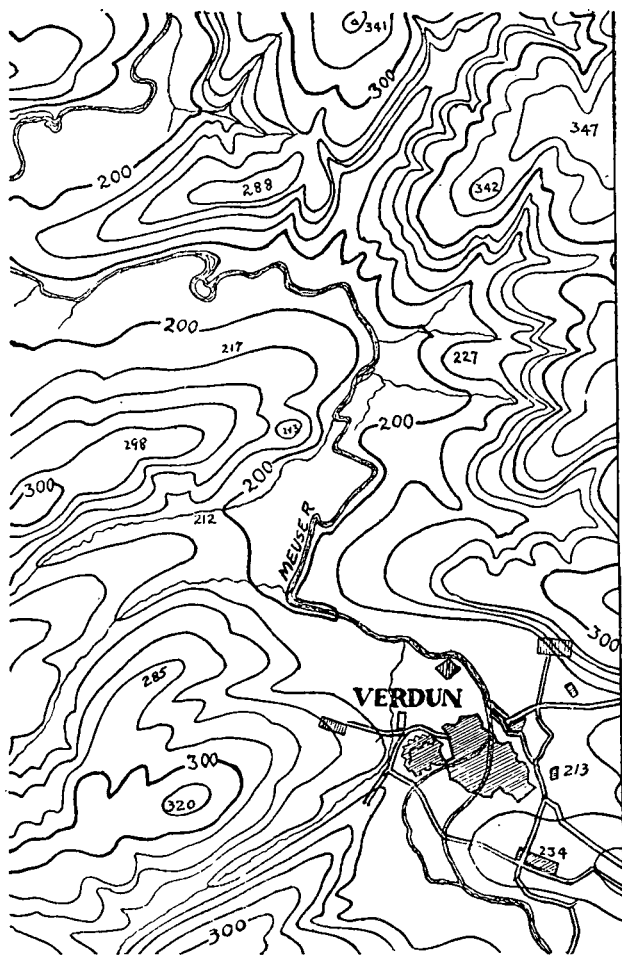

FIGURE 33.—Contour map of same area as hachure map in figure 32.

■ 28. **HACHURES.**—Frequently on foreign maps, a method of representing elevations called hachuring is used instead of contouring. Hachures consist of short lines running directly down the slopes of hills, that is, they show the direction that water would flow downhill. Hence, hachures are at right angles to contours. Steepness of the slope is indicated by thickness and spacing of the lines; steep slopes are shown by heavily inked lines very close together, while lightly shaded lines wide apart show gentle slopes, and level areas are left without any lines whatever. Hilltops, ridges, valleys, and various slopes are easily recognized from hachures but specific elevations cannot be determined accurately unless given in figures. The contour method is better for military purposes. Figures 32 and 33 show the comparison between a hachured and a contoured map.

■ 29. **RIDGE LINING AND STREAM LINING.**—*a. Purpose.*—In order to emphasize the basic structure or master lines of the terrain of a given area, a system known as ridge lining and stream lining is often used. On a map or an aerial photograph thus ridge lined or stream lined, the great mass of detail which may tend to confuse may be neglected for the moment, and those basic structures such as stream systems, ridge lines, and key features can be emphasized. Three steps may be followed in this process.

b. Stream lines.—Study the map or aerial photograph and select the main streams and their tributaries. Emphasize them, preferably by drawing over them in blue, and thus cause the drainage system to stand out.

c. Ridge lines.—Draw a line down the main ridges. This should be done preferably in brown so as not to obscure features lying under the lines. Then select the minor ridges and trace their ridge lines in a similar manner. The number of minor ridges to be included will depend upon the emphasis desired. In drawing ridge lines it is not normal to carry them all the way to the stream. A good system is to stop at the beginning of the flood plane as shown by the increase in space between contours. It will be noted that the tendency at first is to mark isolated ridges, whereas the ridge lines should form a connected structure. If all the ridge lines in

an area are drawn, it usually will be found that they join together into a systematic branching structure like the fingers of a hand or the backbone and smaller bones of a fish. This structure is similar also to the branches of streams; in fact

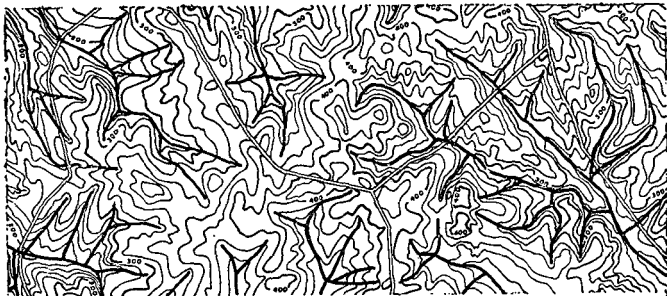

FIGURE 34.—Contoured map with stream lining.

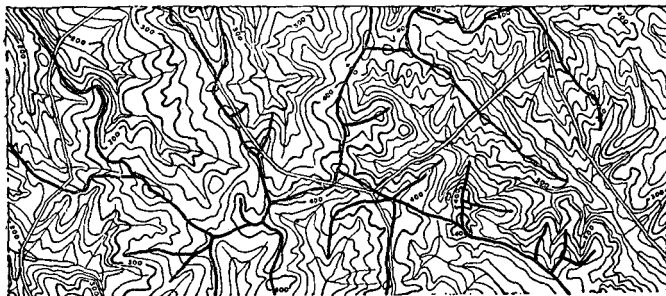
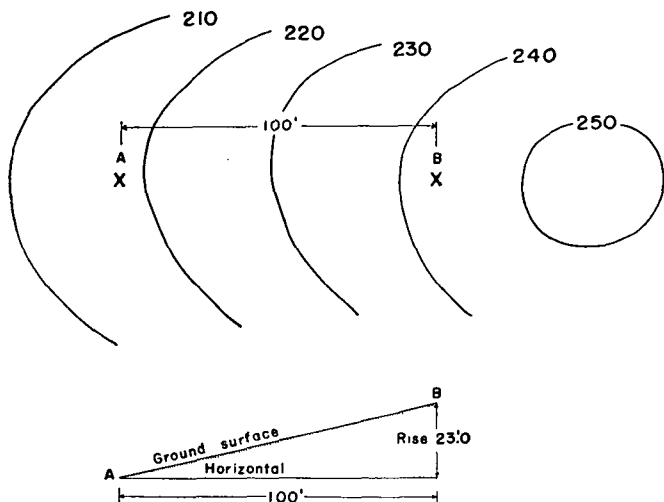

FIGURE 35.—Contoured map with ridge lining.

the branches are fingers of the two systems fitted into each other. Ridge lines do not cross streams. Figure 34 shows a portion of a contour map which has been stream lined; figure 35 shows this same area after it has been ridge lined. Note how the main drainage system and the main ridge lines stand out.

d. Emphasized contours on contoured maps.—Certain contours may be emphasized by use of thicker lines, and it is customary to do this at regular intervals to facilitate the reading of contour maps; for example, on map in figure 1 (back of manual), thicker lines are used at 100-foot intervals. Likewise, commanding elevations may be brought out by coloring the map area between selected contours.

■ 30. SLOPE AND GRADE.—*a. General.*—Slopes and grades are important to the map reader since they affect selection of



$$\text{Expressed as slope in percent} = \frac{23}{100} = 23\%$$

FIGURE 36.—Determination of slope.

routes of travel whether by road or open country, and siting or location of all military works and weapons. In paragraph 26b it was learned that the spacing of contours indicates the slope of the ground. A step further is to determine from a study of contours on maps the amount of slope and express it numerically. There are several methods of expressing

slopes of ground surfaces. The method of expressing slope by percent is the principal one and the only one that will be described in this manual.

b. Slope in percent.—A slope of 1 percent is one in which 1 foot of vertical height is ascended or descended in traveling 100 feet of horizontal distance. A slope of 10 percent is one in which 10 feet are ascended or descended in traveling 100 feet. Thus in figure 36 where AB represents a slope, if the horizontal distance from A to B is 100 feet, and difference of elevation is 23 (or 242—219) feet, the slope of $AB = \frac{23}{100} = 23$ percent. An upward slope is plus, a downward slope minus, that is, the slope from A to B is plus 23 percent, but from B to A is minus 23 percent.

c. Grade.—The slope of road and railroad lines is referred to as grade, and may be computed in a manner similar to that described in *b* above.

■ 31. PROFILE.—*a. General.*—The most satisfactory way of showing the slope of any line on a map is by drawing its profile. A profile between two points is the line (usually irregular) of intersection of an imaginary vertical plane cutting the earth's surface between these two points. For example, in figure 37 imagine a vertical plane passed from above through the earth between the points A and B, and the front half of the hills and ridges removed, just as a cook passes a knife through a cake and removes half. The outline of the surface of the remaining half would be its profile as represented in figure 37②. It has already been seen in figure 29 how profiles may be used to illustrate the different types of slopes indicated by the spacing of contours. Profiles are also a means of determining the visibility or the defilade of points or areas from any selected point on a map. Visibility is discussed in paragraph 32.

b. To draw profile between two points.—Figure 37① represents a contoured map. It is desired to construct the profile of the ground represented by the map between the points A and B. Proceed as follows:

(1) Connect points A and B by a straight line and assume that a vertical plane is passed through this line.

(2) Take a piece of cross section paper or any paper which has parallel lines equally spaced; cut or fold the paper along one of these lines.

(3) Refer to map and determine the highest and lowest elevation along the line AB; number the spaces on the paper

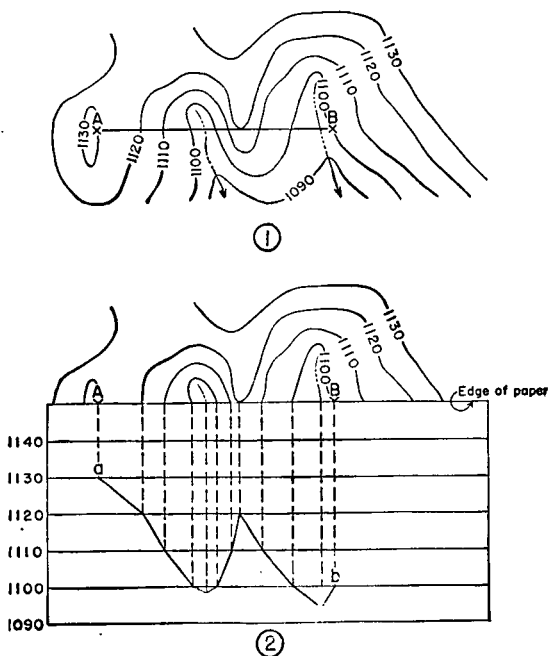

FIGURE 37.—Construction of a profile.

to correspond with the elevations on the map beginning with the highest elevation toward the top edge of the paper (fig. 37②).

(4) Place top edge of the paper along the line AB and where the edge cuts each contour, drop perpendiculars to the line on the paper corresponding to the elevation of the contour being considered.

(5) Connect the points of intersection of the perpendiculars with the lines of the paper. This will represent the profile except between adjacent contours of the same elevation which require the determination of intermediate elevations.

(6) Where the line crosses a crest or a depression an elevation number on the map is sometimes found to assist in completing the profile. Where such elevation numbers are missing, interpolate necessary elevations from the spacing of the contours, using the method described in paragraph 27.

(7) When a profile is desired of an irregular line on the map, such as a road or trench, divide it into a series of sections approximately straight and plot as directed above, turning the paper at each angle to make a continuous profile.

c. Vertical scale.—Profiles usually have an exaggerated vertical scale in comparison with the horizontal scale which ordinarily is the same as that of the map as shown in figure 37②. In the figure, the lines on the paper could represent 10-foot elevations as indicated, or they could represent 5-foot elevations, thus further exaggerating the profile as desired. For constructing profiles, use of cross section paper will be found most convenient since the vertical lines assist in dropping the perpendiculars to the horizontal lines representing the contour elevations.

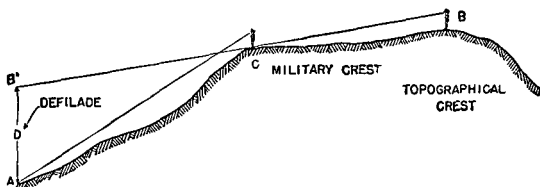

FIGURE 38.—Defilade.

■ 32. VISIBILITY.—*a. General.*—One of the important uses of maps for military purposes is to determine whether a point, a route of travel, or an area is visible from a given point or position. The extent of the area visible affects selection of targets, siting of weapons, and location of defiladed area or dead space (fig. 38). There are various methods of solving visibility problems, but only the ones more commonly used will be covered in this manual.

b. *Inspection.*—Many problems of visibility may be solved by inspecting the map, and determining from the contours the ground slope represented. The representation of ground slopes by contours is described and illustrated in paragraph 26b. For example, in figure 29 it is evident by

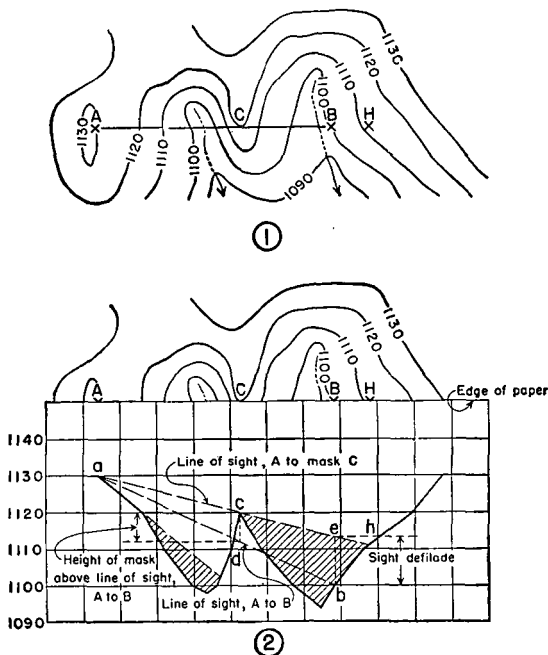

FIGURE 39.—Determination of visibility by profile method.

inspection that an observer at E cannot see the ground at F, this being a convex or humpback slope, while an observer at G can see the ground at H, this being a concave or sway-back slope.

c. *Profile.*—In paragraph 31 it was learned how to construct a profile between two points such as AB on figure 37. Suppose it is required to use the profile method to

determine what points along the line AB are visible from an observer at A. Construct a profile along the line AB as described in paragraph 31. It is evident in figure 39 that

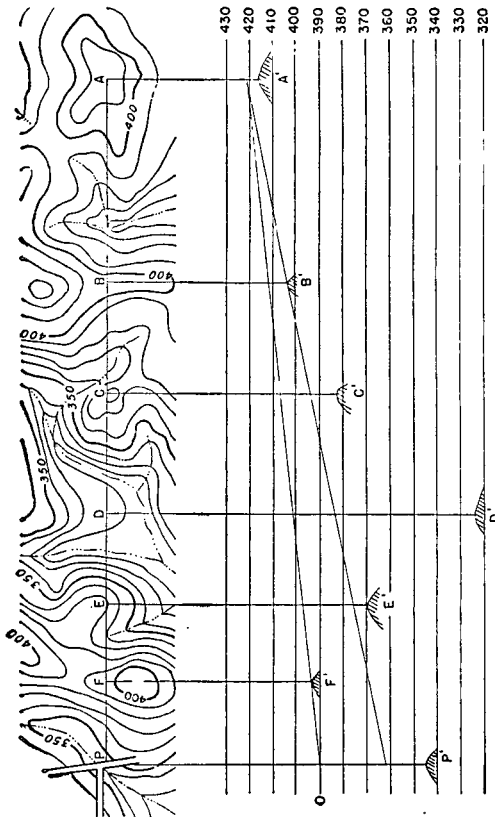

FIGURE 40.—Determination of visibility by hasty profile method.

the portion of the profile that is shaded is not visible from an observer at A.

d. Hasty profile.—Many problems of visibility may be solved without drawing a complete profile. In such cases

only the critical points which may affect the visibility are plotted, such points being first determined by inspection. These points would be the position of the observer's eye, the probable masks (hills or ridges), and the point where visibility is to be determined. This is illustrated in figure 40 which represents a portion of a contoured map. It is required to determine what an observer can see along the line AP from various points along this line, assuming trees and other vegetation do not interfere. It is evident that while at A the observer can see only point B and point F. From B he can see A, C, E, and F, but is unable to see points D and P. This can be continued for other points.

SECTION VII

MAP READING IN THE FIELD

■ 33. **GENERAL.**—All Army personnel should keep in mind the importance of being able to read maps accurately and quickly in the field. Many disastrous mistakes have resulted from a lack of ability to read maps. To be able to read a map properly in the field, the student should be familiar with all material covered in the preceding sections. He should keep in mind that the map and aerial photograph are often the only means available for studying distant or inaccessible areas. He should always take his map into the field with him and constantly refer to it. He should keep his movements plotted on it, especially when operating over unfamiliar territory, and verify his location at every opportunity. He should practice until it is possible for him to secure a clear and accurate picture of the ground from the information given on the map. In addition to material in preceding sections, a few aids to his map reading ability are orientation, use of compass, determination of distance, and names by which ordinary features of the ground are known. A brief description of each of these follows.

■ 34. **ORIENTATION.**—*a. General.*—A person is said to have oriented himself when he stands on the ground and knows the cardinal directions north, south, east, and west. A person is oriented with respect to a map when he knows his position on that map, and a map is oriented when in a nori-

zontal position its north point actually points north. Every stream, road, or other feature on the map is then parallel to its true position on the ground, making it comparatively simple to pick out on the ground objects represented on the map. One who is responsible for guiding by map must know his position on it by constant reference to the map. Normally a map reader can keep himself and his map oriented by observing familiar landmarks. When such marks are not

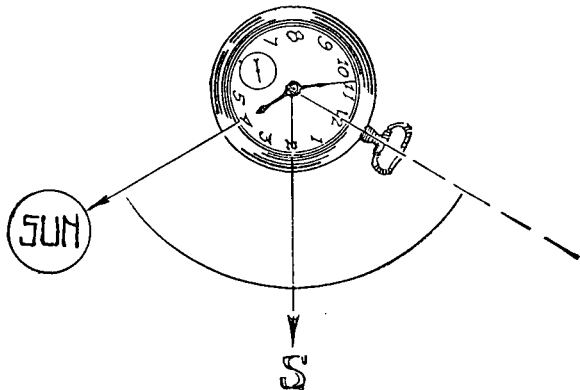

Point hour hand at sun; south is half-way between hour hand and 12 on the dial.

FIGURE 41.—Method of determining direction by watch and sun.

available, the sun, stars, and compass may be used. Figure 41 shows an approximate method of finding south by use of the sun and an ordinary watch showing correct time. Figure 42 shows a method of finding the North Star by use of the pointer stars in the Big Dipper.

b. Method of map orientation.—(1) *Inspection.*—Figure 43 shows how a map may be oriented by carefully observing road system and features in immediate vicinity. It will be noted that the map has been rotated horizontally until the road on the map parallels the road on the ground, care being used to see that positions of nearby ground features are in similar relation to their corresponding conventional signs as shown on the map. This is the most practical method for ordinary

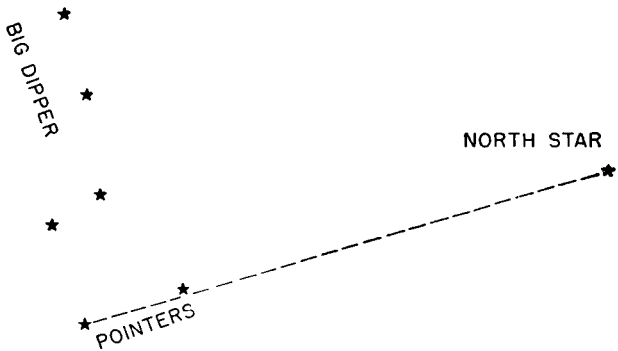

FIGURE 42.—Determining north by use of Big Dipper and North Star.

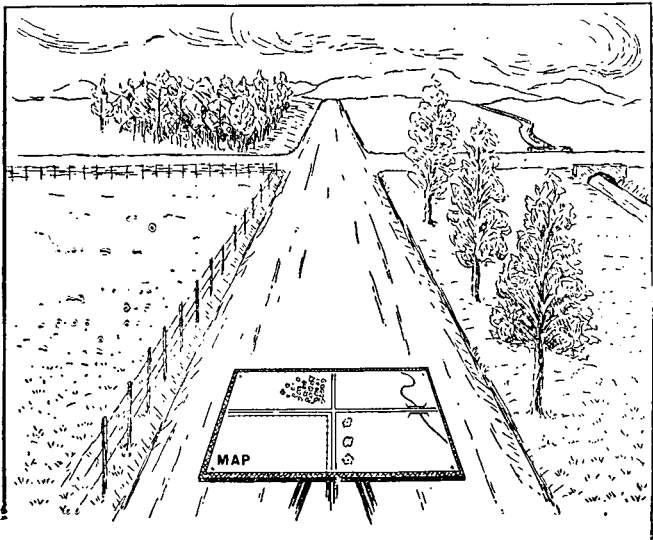

FIGURE 43.—Orienting map by inspection.

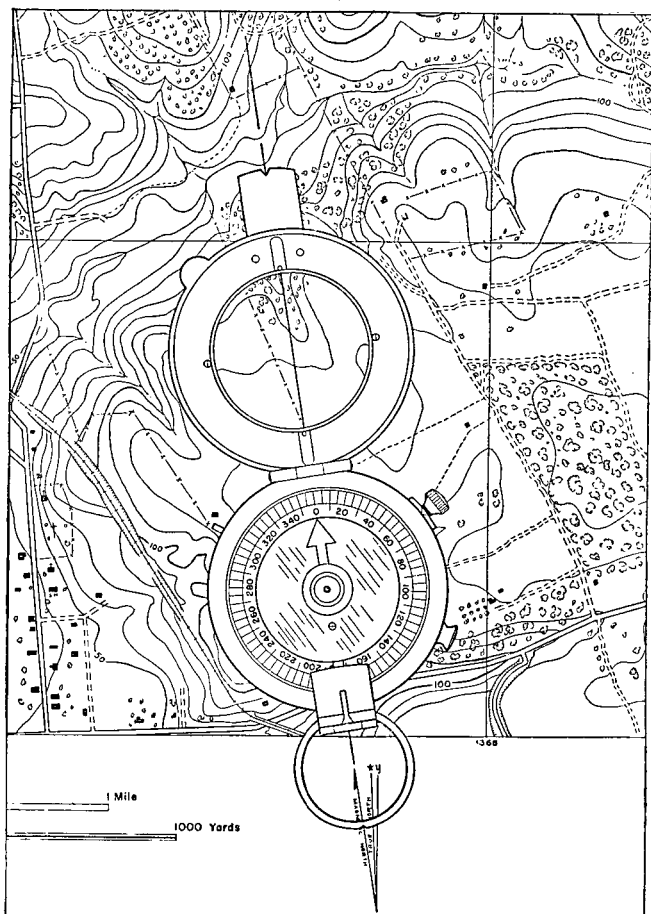

FIGURE 44.—Orientation of map by compass.

purposes and may be used as a rough check on more accurate methods.

(2) *Compass.*—Magnetic north is shown on most maps and is also indicated in the field by the north end of the compass needle. Figure 44 illustrates use of this method. Either

prolong magnetic north line or draw a line parallel to it. Then place compass on map with north point of compass case on this line. Rotate map horizontally until north end of needle coincides with north point of the case. Map is now oriented.

(3) *By means of a distant point when observer's position is known.*—A third method of orientation where a compass is not available and where there are no nearby features suit-

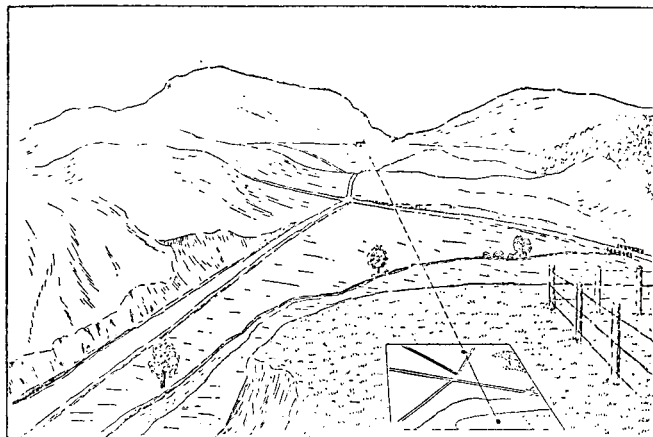

FIGURE 45.—Orienting map by means of distant point.

able for orientation by inspection is illustrated in figure 45. Place a pin at observer's position on map. This may be found by reference to the fence corner (fig. 45). Place another pin on the map location of some well-defined point such as the church. Holding map horizontal, sight at church on the ground along the line of pins. Map is now oriented. A more precise orientation is secured if more than one point can be used. Once the map is oriented, approximate map location of a target or other point may be determined as follows: keeping map in oriented position, sight over pin at observer's position toward designated point and place a pin on line of

sight. From a study of the map or by estimation or measurement of the distance, fix location of the point.

■ 35. FINDING OBSERVER'S POSITION ON MAP.—*a. Inspection.*—If approximate location on a map is known, all the observer has to do is study visible terrain for distinctive features and his position can be found by identifying these features on the map. This procedure is greatly simplified if the map is oriented to the ground. Figure 46 is an example of this method.

b. Striding or estimation of distance when along road, railroad, etc.—This method is illustrated in figure 47. Briefly, the method is to identify on the ground the nearest road bend, road junction, bridge, etc., which appears on the map, such as B in figure 47. The distance to this point is either estimated or measured by striding and position on map is obtained by laying off distance AB to scale of map as indicated in the sketch.

c. Resection from two known points.—This method is illustrated in figure 48. First, orient map accurately. Look over terrain and select two distant visible features on the ground, B and C, which can be located and identified on the map, b and c. Features selected should be so located that lines radiating from observer to them form an angle of as near 90° as possible. Place a pin in b, lay a straightedge (ruler or pencil) against the pin, turn it until it points at B. Draw a ray on the map from the pin toward observer's position. Repeat the same operation with point c. Intersection of the two lines is observer's location on map. Care must be exercised that map remains oriented during entire procedure. If three points are used instead of two, observer's location will probably be more accurate.

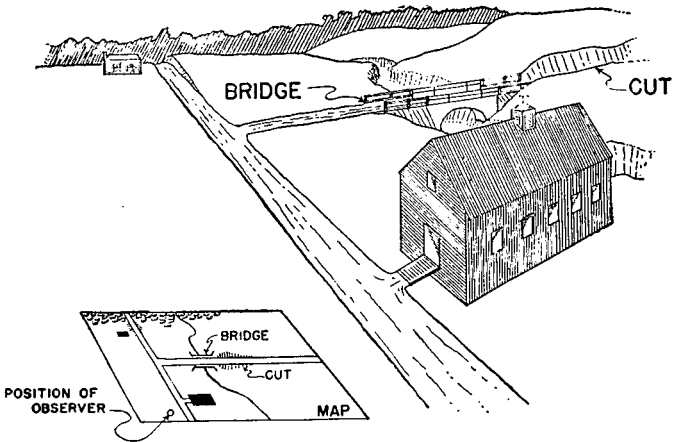

FIGURE 46.—Locating position on map by inspection.

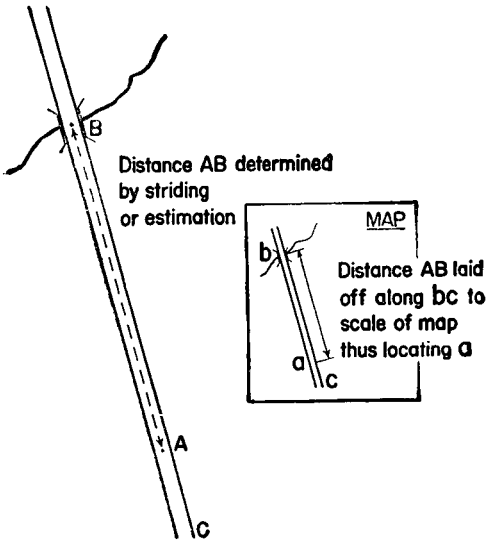

FIGURE 47.—Location of observer's position on map by striding or estimating distance when along road.

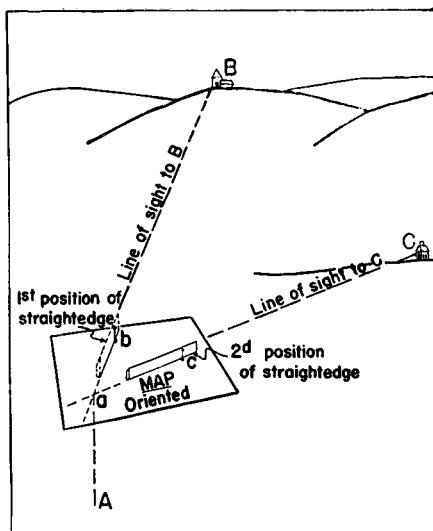

FIGURE 48.—Location of observer's position on map by resection from two distant points (graphic method).

■ 36. MILITARY TERMS FOR TERRAIN FEATURES.—In addition to usual standard terrain terms such as hill, ridge, valley, etc., certain other words are used to describe features of military importance. The most common of these are shown in figure 49.

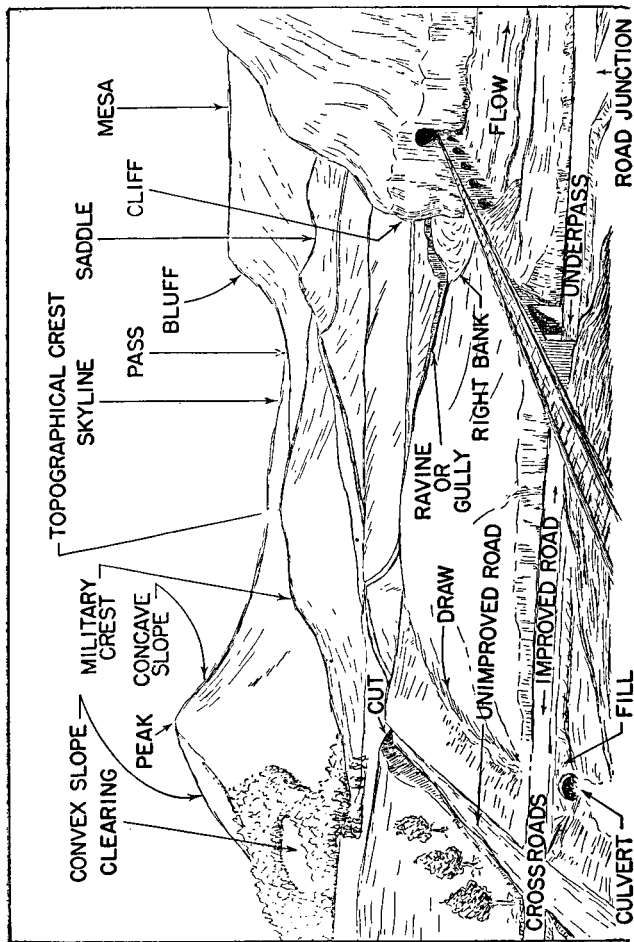

FIGURE 49.—Military features of terrain.

■ 37. DISTANCE.—There are many means of measuring distance. When time is not essential or conditions not unfavorable, pacing or even taping may be used. Along roads measurement of distance by speedometer mileage will be very common. For dismounted troops and for objects off route of travel for motorized troops, distances normally will be estimated by eye. All personnel should practice until they acquire reasonable skill in estimation by eye. However in some conditions, for example, night patrolling or marching over broken terrain, all such methods are impracticable. For such operations two other methods may be used. In one, the leader can scale off the distance he must travel on his map and then locate and identify some prominent terrain feature at the end of his march. He has then merely to keep going until he comes to this feature. In the second method, he can reduce distance to time. Since the normal marching rate is 1 mile in 20 minutes, this reduction is very simple. If he is sent down the road a distance of 2 miles, he has merely to walk for 40 minutes and he should be near or at his destination.

■ 38. COMPASS.—*a. Types.*—The three types of compass issued in the service are prismatic, lensatic, and watch. The watch compass shown in figure 8 is being replaced by the lensatic compass. Descriptions of the other two types are given below.

(1) *Prismatic.*—The prismatic compass is shown in figure 50② showing the more important parts labeled. It consists of a case containing a magnetic dial (b) balanced on a pivot, a hinged cover (d) with a glass window, a holding ring (e) and an eyepiece (a) containing a prism for reading graduations on the dial. The dial has two scales, the outer scale to be read through the prism or eyepiece and the inner to be read directly. Both scales are graduated from 0° to 360°. The north point is indicated by an arrow of luminous paint. The glass cover has an etched line (f) which may be used like a front sight, and the eyepiece (a) has a slot that may be used as a rear sight. In case the window in this cover is broken, a horsehair or a fine wire can be threaded through and stretched between the two holes in the cover provided for that purpose. Closing the lid operates a lever (g) which raises the dial to protect the compass from injury when not

in use. To lower the dial push clamp (g) forward with the thumb. A second glass protects the face of the dial when the lid is raised. On it is painted a luminous movable index which is used to set angles from the line of sight or north point. This glass can be revolved by unlocking the set screw (h) and turning the corrugated brass ring so that the movable index points at any angle from the line of sight. It can then be set at this angle by tightening the set screw (h). A rubber washer is fixed to the bottom of the case to prevent slipping when laid on smooth objects. The compass is carried in a stout leather case with a belt loop. The outside of the brass case is marked with two scales, one to read azimuths, and the other to read compass directions. Figure 52 shows one use of this outside scale. The compass is affected by presence of iron, steel, or electricity, and will not give accurate readings near an automobile, tank, fieldpiece, machine gun, or power line. A steel helmet, rifle, or pistol on the person of

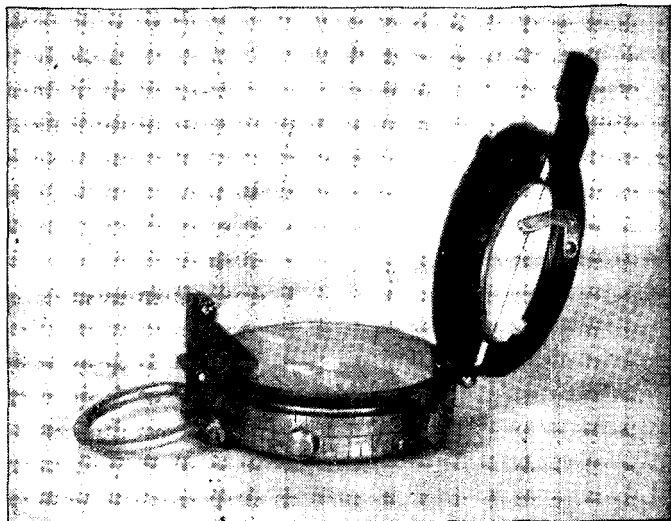

① Photographic view.

FIGURE 50.—Prismatic compass.

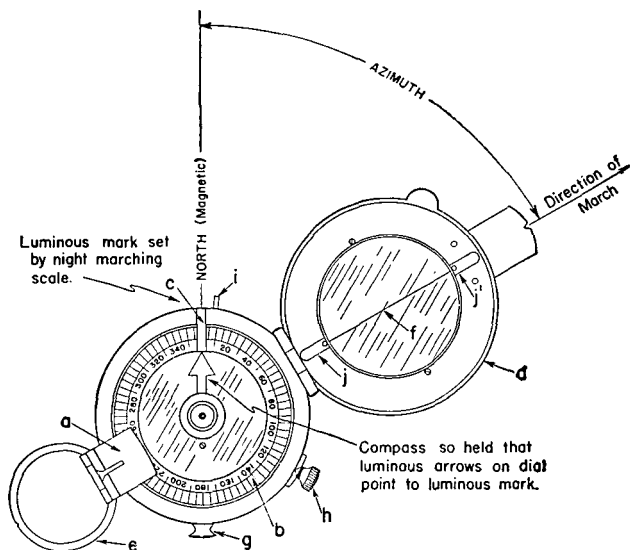

- | | |
|---|-----------------------------------|
| a. Eyepiece | e. Holding ring |
| b. Compass card or dial (with luminous arrow) | f. Etched front sight cover |
| c. Movable index mark on crystal (luminous) | g. Clamping knob for compass card |
| d. Hinged cover | h. Index locking screw |
| | i. Dampening plunger |
| | j. Luminous marks on cover |

⊙ Parts labeled.

FIGURE 50.—Prismatic compass—Continued.

the observer may influence the needle and make readings inaccurate.

(2) *Lensatic*.—Figure 51 shows two views of a lensatic compass. It functions in much the same manner as the prismatic compass. The hinged eyepiece is a narrow piece of metal containing a magnifying lens in the larger circular opening. When the eyepiece is tilted so that it is aimed at the forward part of the compass face, the observer is able to see both the scale and a distant point at the same time. It should be noted that the face has two scales, the outer

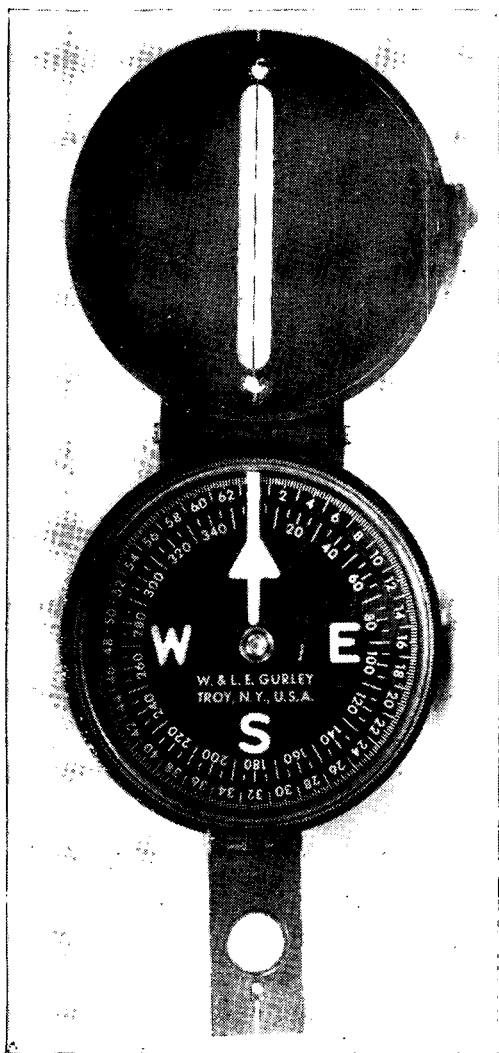

①

FIGURE 51.—Lensatic compass.



②

FIGURE 51.—Lensatic compass—Continued.

one showing mils, and the inner one showing degrees. The compass is made of light aluminum and is designed so that it may be carried in a pocket.

b. Measuring azimuth with prismatic compass.—To read the azimuth to any point proceed as follows (fig. 50②):

(1) Raise cover (d) and eyepiece (a) vertically, and lower needle dial at (g).

(2) Hold compass horizontally in front of the eye and pointing in the direction of object azimuth of which is desired. In doing this utilize every possible means for holding compass and eye steady. Methods used are somewhat similar to those used for sighting a rifle. A good method is to rest

SCOUT ADVANCES ON A KNOWN
AZIMUTH. HE HENCE ARRIVES
AT A KNOWN POINT OUTSIDE
THE ENEMY'S POSITION. HE
LIES HERE UNTIL SOUNDS
INDICATE POSITION OF ONE
OF THE ENEMY OUTGUARDS

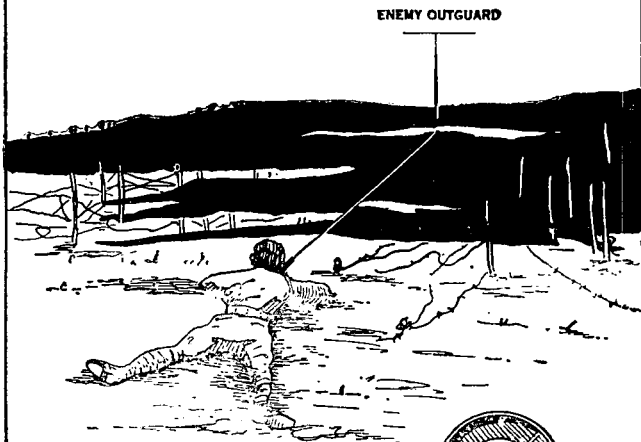

WITH COVER DOWN AS SHOWN
SCOUT SIGHTS IN DIRECTION OF
SOUND, TURNS LUMINOUS INDEX
ON THE ROTATING RING
TO POINT OVER NORTH END OF
ARROW. AZIMUTH IS NOW
RECORDED AND MAY BE
READ ON OUTSIDE SCALE.
SCOUT ALSO ESTIMATES
DISTANCE TO SOUND

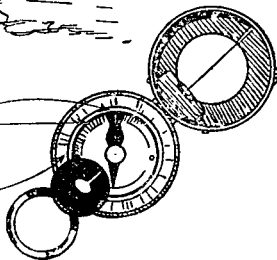

FIGURE 52.—Use of compass dial.

head, wrist, and body against a good substantial tree or other nonmetallic object. A prone or sitting position similar to that assumed for firing a rifle is also suitable. The dial may be dampened by operating the plunger (i) with index finger of left hand.

(3) Sighting through slot in eyepiece, line up object with etched line (f) in cover. Hold compass steady until dial comes to rest. Read azimuth indicated on dial as seen through eyepiece. This will be the magnetic azimuth of the line from observer to object.

c. Marching by compass.—(1) *Day.*—Often troops are ordered either to march or attack cross country according to given azimuths. Such troops might include patrols or individuals on scouting or messenger missions. Patrol leaders or unit commanders may compute from a map azimuths of various legs of their routes to prevent getting lost. Map azimuths must then be converted to magnetic azimuths before they can be used with the compass. Having determined this magnetic azimuth, the leader holds his compass steady and turns it until required azimuth is read on the dial (fig. 53). He then sights along axis of the compass as described in *b(3)* above and selects a house, tree, rock, or other easily recognizable feature of the landscape on this line of sight. He then marches toward this selected feature until he reaches it or loses sight of it. He then takes another sight as described above and selects a new feature. This is repeated until he reaches his destination. Note that the compass is used to select successive features on the line of march and is not used when actually marching.

(2) *Night.*—For marching at night, movable index (c), luminous marks (j-j') on inside of cover, and azimuth scale on outside of case are used (fig. 50②). To march on given azimuth at night, set movable index at desired azimuth, rotate compass until needle points at movable index, and then select some feature on the skyline that is on the axis of the compass. March toward this selected feature. The axis of the compass can be determined by means of the luminous marks (j-j'). Setting the compass must be done in the light, usually by flashlight, screened from observation. On

very dark nights where the skyline is not visible, it may be necessary to send one man ahead to the limit of visibility, line him up on desired azimuth, and then walk toward him, repeating this as often as is necessary.

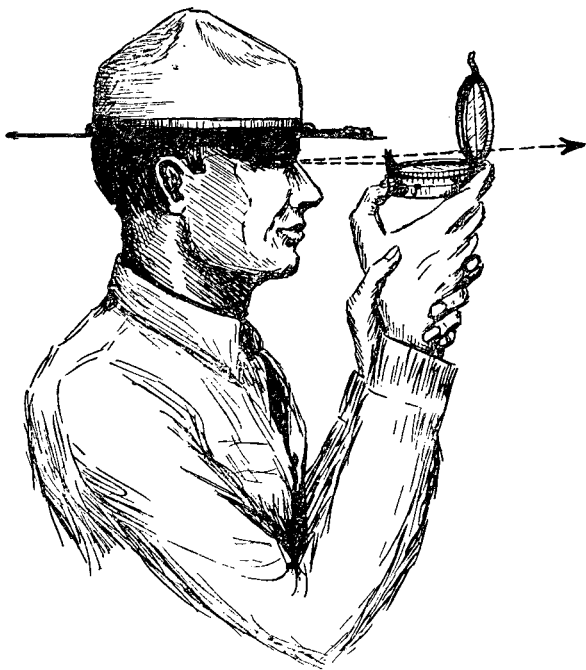

FIGURE 53.—Prismatic compass open and in position for measuring azimuth in daylight.

SECTION VIII

AERIAL PHOTOGRAPH READING

■ 39. GENERAL.—*a. Importance.*—Aerial photographs are used for many different purposes in connection with military operations. In this manual they are considered primarily in conjunction with or as substitutes for topographic maps. The

ideal situation is to have an accurate topographical map and a recent aerial photograph of the same area. During the first few days or even weeks in a new theater of operations there is a great possibility that the only up-to-date information of the terrain available would be that obtained from aerial photographs. They would be used in determining distances and directions, and in selecting routes in much the same manner as ordinary topographic maps.

b. Types.—(1) Vertical photographs are those made when axis of the camera is kept as nearly vertical as possible.

(2) Oblique photographs are those made when axis of the camera is deliberately tipped from the vertical.

(3) Composite aerial photographs are made with cameras having one principal lens and two or more surrounding and oblique lenses. The several resulting photographs are corrected or transformed in printing so as to permit assembly as verticals with the same scale.

c. Marginal data on aerial photographs.—(1) As aids in reading and use, aerial photographs used for photomaps will have information along the black strip at the bottom, reading from left to right, as follows:

(a) An arrow one-half inch in length in the lower left hand corner of the negative indicating north, with letter N superimposed over center of shaft.

(b) Name of locality or nearest locality.

(c) Approximate military grid coordinates of center of photograph.

(d) Scale of photograph expressed as a representative fraction in case of a vertical, altitude above ground in feet and focal length of camera in case of an oblique.

(e) Hour.

(f) Date arranged in the following order: day, in figures; month, in letters; and year, in figures.

(g) Designation of squadron.

(h) Serial number of negative. In addition to a north point, the following is the legend on a vertical:

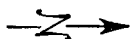
 Saranac, N. Y.—(321-437)—1:20,000—(2:00 P.M.)—(24-Aug-40)—97th—M5. (See fig. 62.)

(2) Mosaics and wide coverage photographs may have in addition to that listed above the following information:

(a) Marginal information similar to that shown on maps such as the graphic scale in yards.

(b) Some system of grids, preferably the atlas grid described in paragraph 44.

(c) Names of important features such as towns, streams, mountains, highways, etc.

■ 40. OBLIQUE.—Normally in making obliques the photographs are taken over the side of the cockpit with the camera.

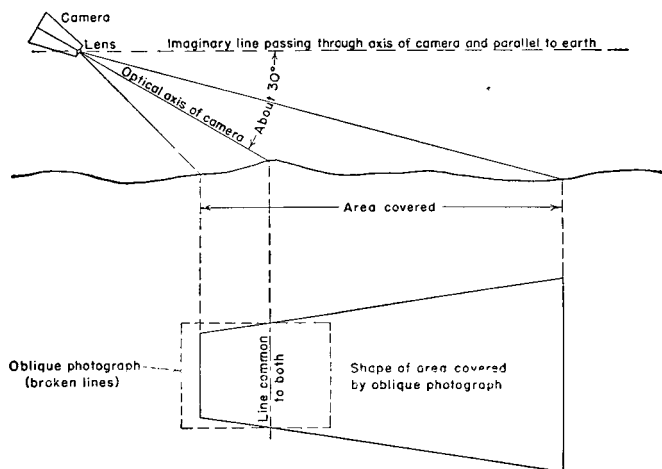

FIGURE 54.—Relative shape of area covered by oblique photograph compared to photograph itself.

intentionally tilted at an angle which will vary according to the mission, but is usually about 30° below the horizontal as shown in figure 54. This procedure gives what is known as a low oblique (fig. 55). Obliques which include the horizon are termed high obliques (fig. 56). Figure 54 also shows the relative shape of the area covered by an oblique photograph as compared to the photograph itself. Note the actual photograph is a rectangular print whereas the area covered by the photograph has the shape of a trapezoid and is much larger. Distances on oblique photographs cannot be scaled



①

FIGURE 55.—Low oblique.

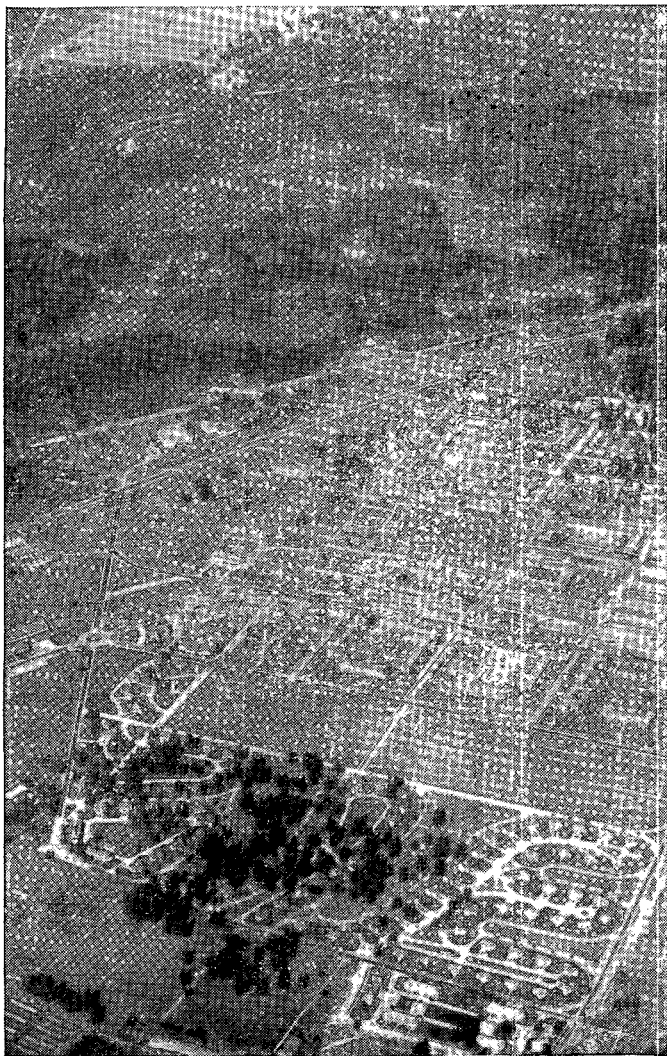

FIGURE 55.—Low oblique—Continued.



FIGURE 56.—High oblique.

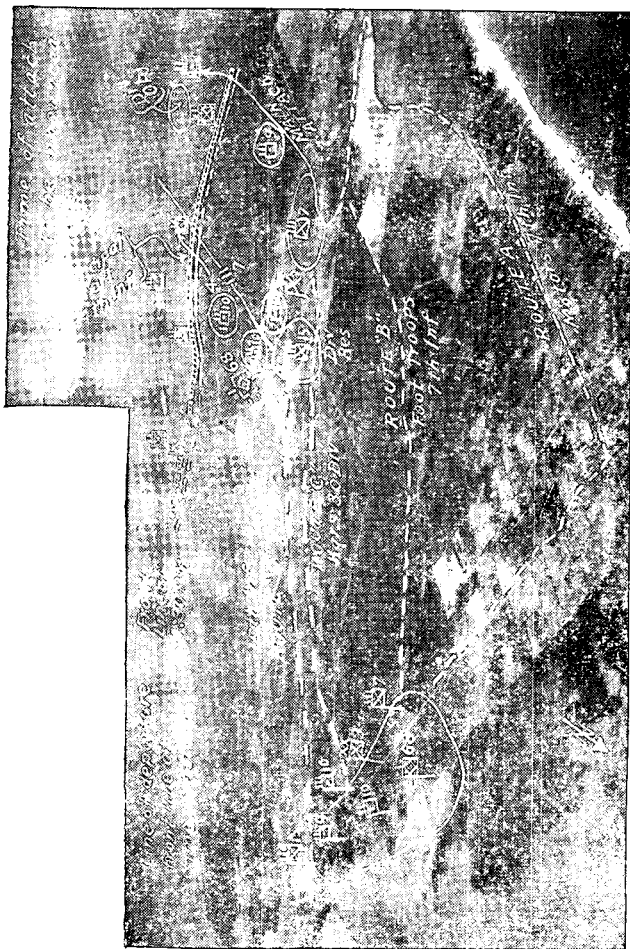

FIGURE 57.—Oblique photograph used as map substitute to accompany oral field order.

accurately. However, since the oblique picture is taken from a viewpoint similar to that of an observer on a high hill, terrain features have a more normal appearance than they do in a vertical; this characteristic makes them more useful for the study of hills, valleys, buildings, roads, etc. They can also be used to accompany operations or field orders. As shown in figure 57 it is possible to show the line of departure, routes from bivouac to assault positions, assembly positions, boundaries between units, objectives, and information of the enemy.

■ 41. VERTICAL.—Vertical photographs are usually taken through an opening in the floor of the airplane cockpit perpendicular to the surface of the earth. Each photograph covers a comparatively small ground area and shows the area somewhat as it would appear on a detailed map or sketch of similar scale. Figure 58 shows photographs taken from different altitudes of the same general area. Scale (RF) of each is given below it. Obliques of the area are shown in figure 55. Comparison of the areas covered for different scales should be made the subject of careful study. Figure 1 (back of manual) has these same areas outlined in heavy black lines. Learning to read a vertical photograph is similar to learning to read a map. It consists in being able to recognize familiar objects on the landscape from their appearance on the photograph, to orient the photograph, to determine its scale, and to determine distance and direction. A photograph however is not as easy to read as a map. Important features on a map are emphasized and always are shown in the same manner. On a photograph important features such as roads, railroads, bridges, and streams may appear less important than a great amount of unimportant detail, or may be completely hidden by trees or shadows. Dissimilar objects such as roads, railroads, and canals may look alike, and the same objects may appear to be different on various photographs or even on different parts of the same photograph. Also, a single vertical photograph unlike a topographic map contains no definite information of ground forms and elevations. Hills, ridges, and depressions are difficult to visualize unless an analysis of the drainage system within the area is made. Even



① Scale, 1:22,480.

FIGURE 58.—Vertical photograph.

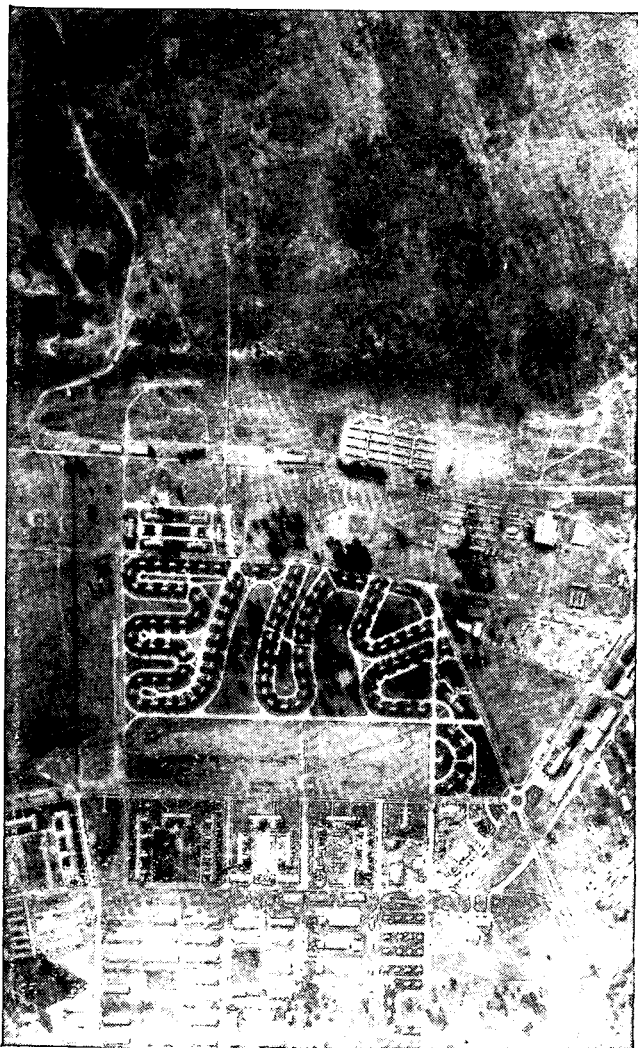

© Scale, 1:16,000 (approximate).
FIGURE 58.—Vertical photograph—Continued.

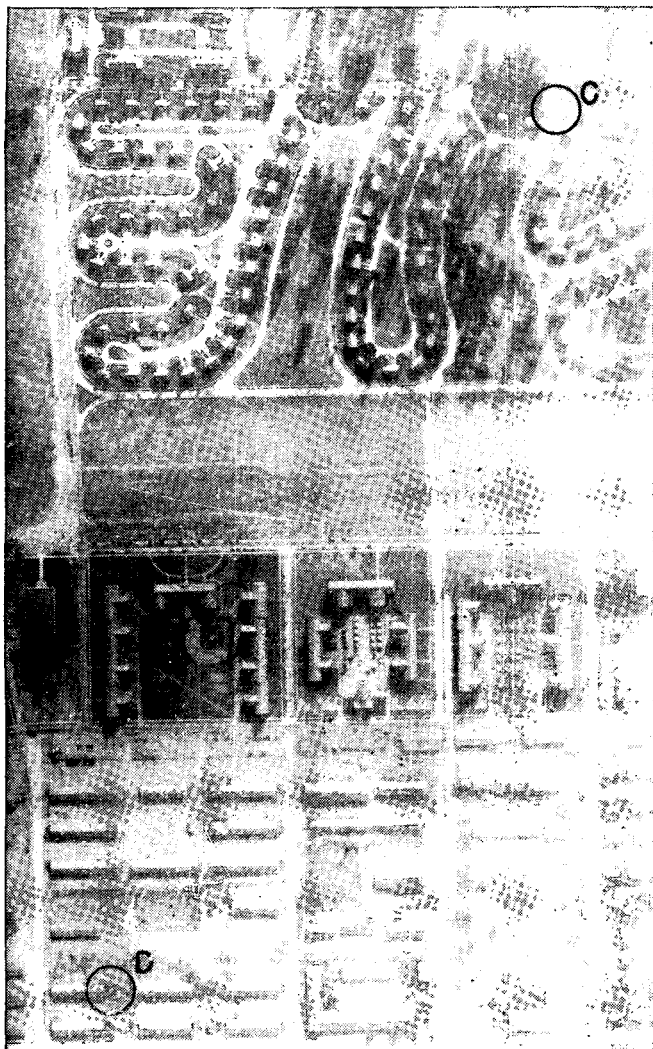

© Scale, 1:7,813.
FIGURE 58.—Vertical photograph—Continued.

when this is done relative elevations are not apparent on the photograph. On the other hand, an aerial photograph is very valuable for the reasons that it—

a. Possesses in pictorial form a wealth of detail which no map can equal.

b. Can be prepared for use in a short time, much quicker than making a new map.

c. Is up to date.

d. Can be made of any area, even those inaccessible to ground mapping parties.

■ 42. IDENTIFYING TERRAIN FEATURES.—a. Identifying features of terrain on photographs requires a certain amount of practice which is best gained by actually comparing the photograph with the ground. When this is not possible, the next best method is to compare photographs with a good map of the same area. Actual identification of objects on an aerial photograph or on a mosaic is effected through one or more of the following means:

(1) Shape of object.

(2) Its tone, or relative colors from white through various shades of grey to black.

(3) Shadow it casts.

(4) Apparent or relative size.

b. In identifying features always hold the picture so the shadows are falling toward the body. Figure 59 shows several ground features numbered to correspond to the numbers of the subparagraphs below containing their description. When reading the description, look at figure 59 and note how reasons given for each identification apply.

(1) Plowed field looks light in the photograph because it reflects a relatively large amount of light.

(2) Meadow looks darker largely due to the shadows of the grass. The meadow is said to have more texture than the field. The difference between the meadow and the field is similar to the difference between satin and plush velvet. Although both are the same color, the plush looks darker due to the shadows of the hairs which stand erect, but it can be made to look lighter when smoothed down.

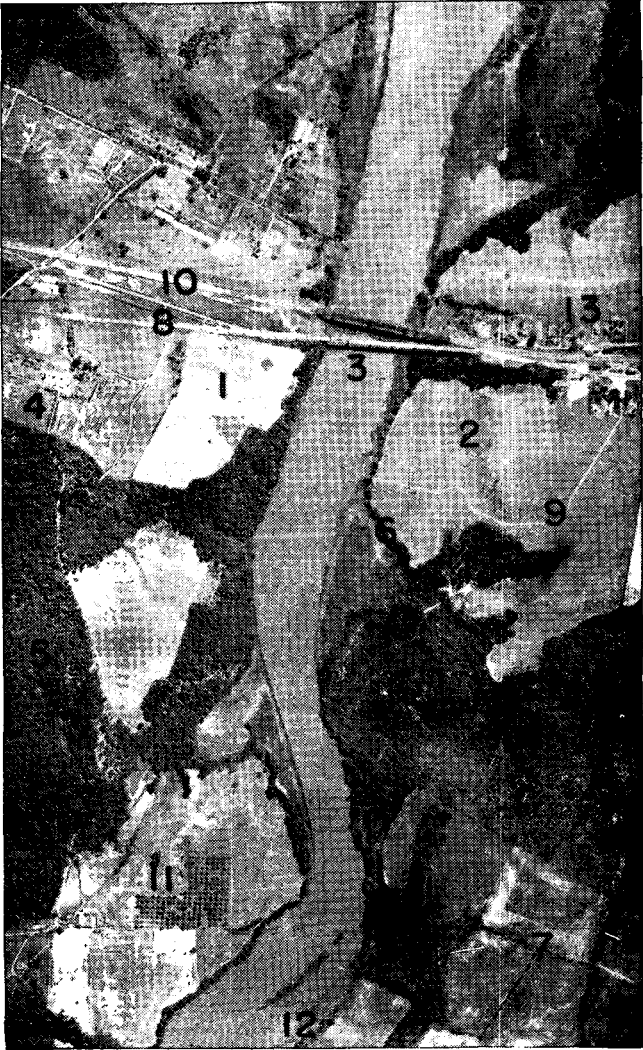

FIGURE 59.—Identification of terrain features.

(3) Bridge looks lighter than the water. It can be identified by its size, shape, and its shadow on the stream.

(4) Building can be identified by its size, shape, difference in appearance of the two roof slopes, and by its shadow. The shadow looks darker than the building.

(5) Woods appear relatively dark because of deep shadows of the trees. They have much texture and reflect little light.

(6) A stream can be identified by its meandering course. Even through open fields some trees or bushes usually grow along its banks. In a dense wood it will appear as a thinning out of the surrounding growth. The water looks very light or dark, depending upon the relative positions of sun, camera, and water.

(7) Fence lines are identified by difference in texture between fields they separate and usually look dark in the photograph because of shadows of bushes growing along them.

(8) Roads are identified by their straight lines, uniform width, and the fact that their surfaces are usually smooth and reflect much light. (Modern open asphalt texture surfaces will appear darker than other road surfaces.)

(9) Trails are also light but are more variable and narrow in width and more crooked than roads.

(10) Railroads have more gradual curves, are straighter, and darker in appearance than most roads.

(11) Orchard is identified by its shape and by the straight and regular rows of trees. Shadows of equal length show the trees are all of about the same height.

(12) Mud flats along the stream look darker than the water and have lighter spots in them due to pools of water.

(13) Cluster of buildings shows this is a village.

c. A careful study of figure 60 combined with a study of figure 58①, ②, and ③ compared with the map (fig. 1, back of manual) should make the student reasonably proficient in interpreting aerial photographs. It should be remembered that the pictorial effect of aerial photographs is influenced by shadow. In order that this effect will aid rather than hinder the student, he should place the photograph on a table between himself and a lamp, window, or other source of light, shifting it to avoid the glare from its surface and so that shadows on the photograph fall toward him. In this position

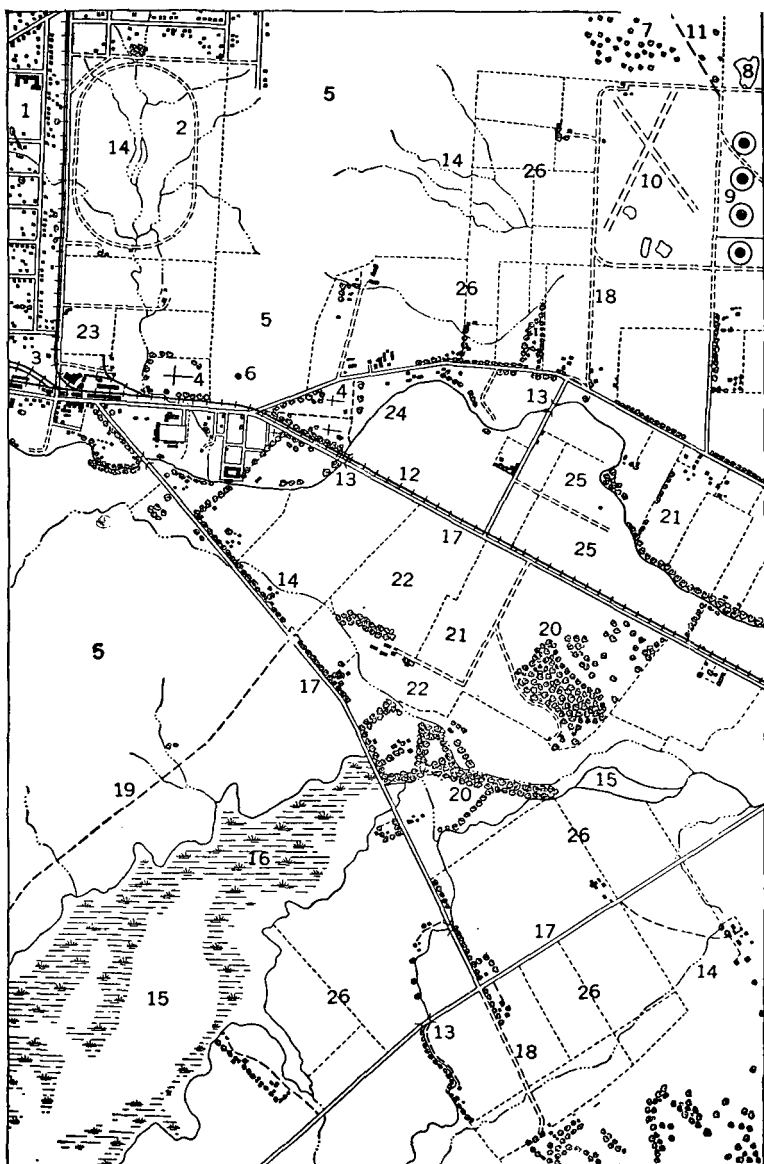

1. City; 2. Race track of fair grounds; 3. Railroad yards; 4. Cemetery; 5. Topography with low brush on hillside; 6. Concrete water tank; 7. Scattered wood; 8. Pond; 9. Oil tanks; 10. Airport with runways; 11. Oil pipe line; 12. Railroad; 13. Bridges; 14. Intermittent drainage; 15. Lake; 16. Marshes; 17. First class roads; 18. Secondary roads; 19. Trail; 20. Woods; 21. Orchards; 22. Vineyards; 23. Baseball park; 24. Streams; 25. Pasture; 26. Cultivated fields.

① Vertical aerial photograph.

FIGURE 60.—Interpretation of photographic detail.

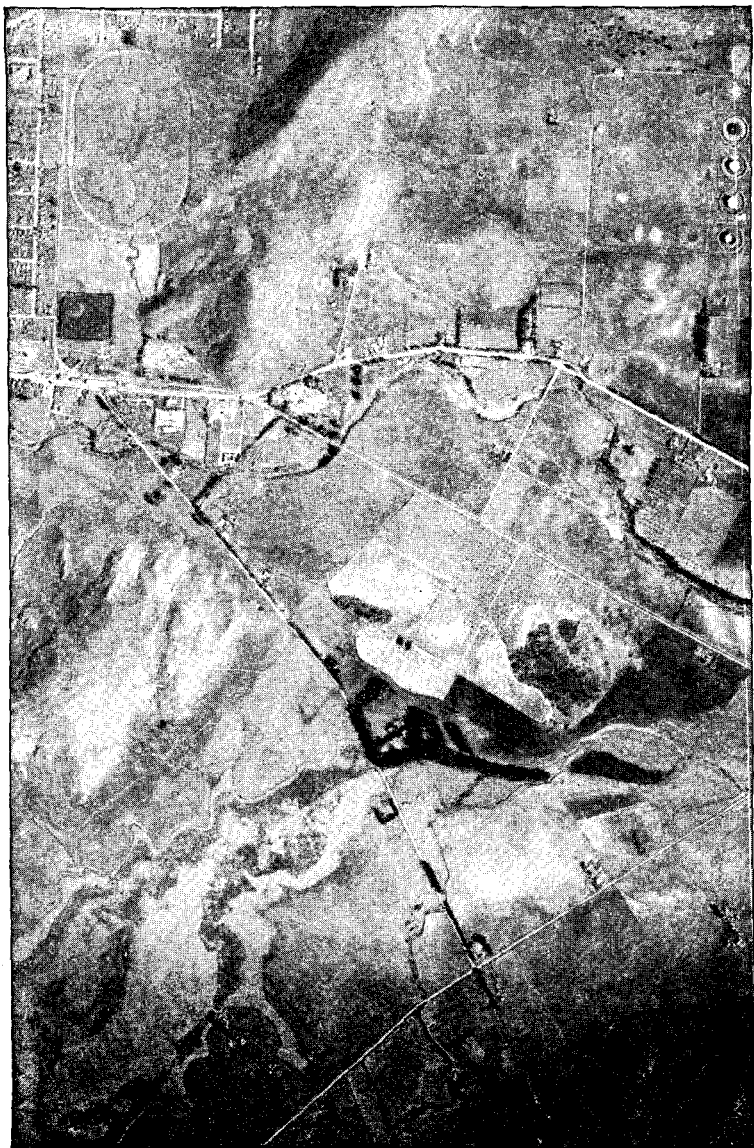

© Map of area shown on photograph.

FIGURE 60.—Interpretation of photographic detail—Continued.

objects will have their normal appearance. If the photograph is reversed, that is, placed so that the shadows fall away from the student, actual hollows may appear as hills and trees as holes in the ground.

■ 43. ORIENTATION.—*a. With map.*—(1) When the photograph is used in conjunction with a map it should be oriented with the map. Maps are printed with the north of the map at the top and all lettering, grids, etc., are added on that basis. However, no attempt is made to take photographs to fit this scheme. Photographs may be received without any lettering or direction arrow for orientation. Consequently it may be necessary to study the photograph and identify objects to use in orienting it. When objects shown on the map are found on the photograph it is a simple matter to orient the photograph with respect to the map. Road systems and streams are useful for this purpose. A magnetic north line should then be drawn on the photograph parallel to that on the map.

(2) Another method of drawing the magnetic north line on a photograph is to select two points on the photo that can also be easily identified on the map. The points should be fairly far apart, and the line joining them should pass close to the center of the photograph (points A and B, fig. 58①). Measure on map azimuth of line joining these points. Convert this azimuth to magnetic azimuth. In figure 1 (back of manual) magnetic azimuth of the line A to B is $328^{\circ}30'$. Lay protractor on the photograph (fig. 61) with center of protractor at A and line AB cutting the $328^{\circ}30'$ reading. The base line of the protractor is now lying on magnetic north and south line with north toward the 360° reading. A line with N arrow is drawn parallel to this where desired on the photograph. Further details of this process are given in FM 21-26.

b. With ground.—A photograph may be oriented with the ground by placing some well-defined line as a road on the photograph parallel with the same line visible on the ground. This is similar to the orientation of the map described in paragraph 34b. The same method is used in locating

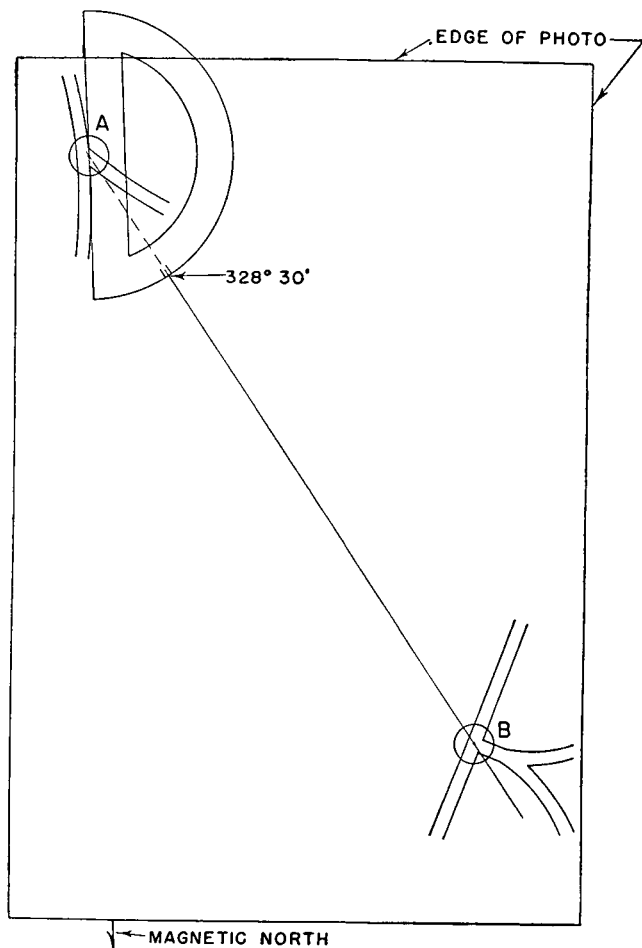

FIGURE 61.—Determining magnetic north on a photograph.

observer's position on a photograph as is used on a map (see par. 35).

c. By shadow.—There may be times when an observer in the field finds it impossible to orient a vertical aerial photograph by either of the above two methods. A third method of rough orientation by use of shadows can be used. In the northern hemisphere shadows fall to the northwest in the morning and to the northeast in the afternoon. Assume the photograph is taken between the usual hours for aerial photography, that is, 10:00 A.M. to 2:00 P.M. The photograph is laid on the ground with the shadows pointing slightly west of north if the photograph was taken in the morning or slightly east of north if taken in the afternoon. The photograph is then approximately oriented. If the exposure is before 10:00 A.M. or after 2:00 P.M., the photograph must be turned west or east of north a correspondingly greater distance.

■ 44. ATLAS GRID.—Because of variations in scale, other inaccuracies, and difficulty of locating grid lines, the military grid is not used on photographs or uncontrolled photomaps. The atlas grid is used instead with grid lines always 1.8 inches apart regardless of the scale. With this interval, on a 1:20,000 photograph the grid lines are about 1,000 yards apart. The lines are numbered from the bottom up, and lettered from left to right. Starting at the left edge, the first line is A, the second B, etc. Starting at the bottom the first line is 1, second 2, etc. Therefore, the origin of coordinates at the lower left-hand corner of the photograph is (A.0-1.0) (fig. 62). Points can be located accurately by decimals of the grid interval. For instance, the decimal coordinates of point P would be written (C.5-4.2).

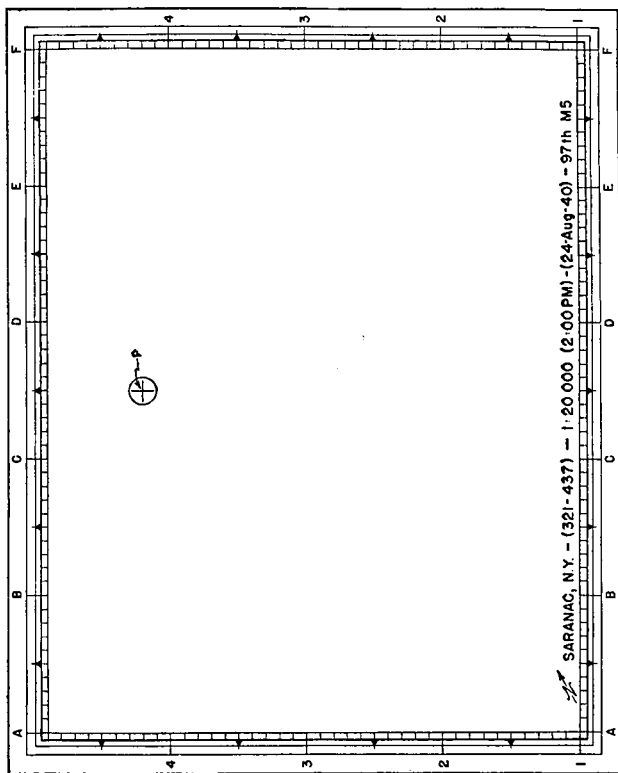

FIGURE 62.—Atlas grid and marginal data.

■ 45. SCALE.—Customarily photographs intended to be used as substitutes for maps will be marked as shown in paragraph 39c. However, they may be received without complete information as, for example, with the scale omitted. In this case the scale must be determined by some other method.

a. *By focal length and altitude.*—In certain instances, the focal length and altitude at exposure may be shown. This information would appear in the marginal data as follows: (12''-20,000'). This means that the picture was taken with

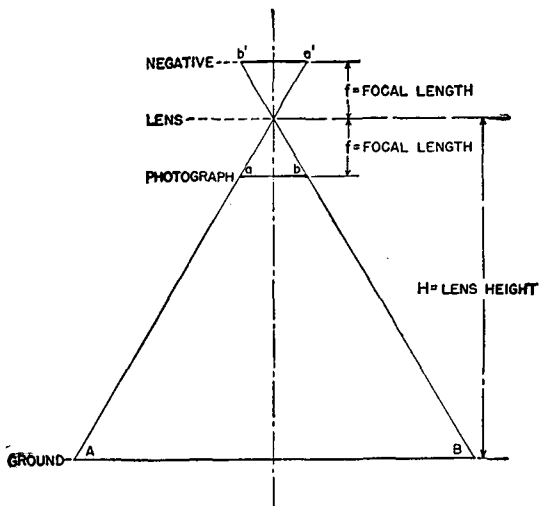

FIGURE 63.—Diagram showing relation of scale, focal length, and lens height.

a camera focal length of which was 12 inches and was 20,000 feet above the ground at time of exposure. By inspection of figure 63 it may be seen that there is a direct relation between focal length of the camera, height of the plane, ground distance AB and corresponding distance ab on the photograph or

$$\frac{f}{H} = \frac{ab}{AB} = \text{R.F.}$$

If the focal length is 1 foot (12 inches) and the altitude of the plane is 20,000 feet, then the scale of the photograph will be $\frac{1}{20,000}$ or $RF=1:20,000$.

If the focal length had been 6 inches, then the scale would have been $\frac{6/12}{20,000} = \frac{1/2}{20,000} = \frac{1}{40,000}$ or $RF=1:40,000$. Hence the general expression or formula is:

$$RF = \frac{\text{focal length in feet}}{\text{height of plane in feet}}$$

In some cases the altitude given is the elevation above sea level, and not the elevation above the ground. If the average ground elevation is much above sea level, allowance must be made for this by reducing the plane's height by the elevation of the ground. For instance, in the example given just above, if the elevation of the ground had been 2,000 feet and the altitude given had been the elevation above sea level, the RF would have been actually $\frac{1/2}{20,000 - 2,000} = \frac{1}{36,000}$ or 1:36,000 instead of 1:40,000.

b. By comparison with map or ground distance.—The average scale of the photograph may be computed by comparison of the distance between two points on the photograph with corresponding distance between the same points on the ground or on a map. For best results the points chosen should be located on the photograph so that straight lines joining them pass fairly near to the center and well across the face of the photograph. For accurate determination see FM 21-26. If required to find the scale of the photograph in figure 58① by comparison with the map in figure 1 (back of manual), select two points such as A and B, that are easily recognizable both on the photograph and on the map. Measure the distance between them both on the photograph and on the map. In this case the map distance is 5.62 inches which on the ground would be $5.62 \times 20,000 = 112,400$ inches since the scale of the map is 1:20,000. Assume the distance between points A and B on the photograph is 5.0 inches. Since it is known that the distance on the ground is 112,400 inches then the RF of the photo is $\frac{5}{112,400} = \frac{1}{22,480}$ or 1:22,480.

Now suppose it is required to find the scale of the photograph in figure 58③ by comparison with the map in figure 1 (back of manual). Select two points such as C and D that can be easily identified both on the photograph and on the map. Proceed as above and in this case the map distance is 2.09 inches which would be $2.09 \times 20,000 = 41,800$ inches on the ground. Measure the distance CD on the photograph. Assume it is 5.35 inches. Therefore the RF of the photograph is $\frac{5.35}{41,800} = \frac{1}{7,813}$ or 1:7,813. Note that in both examples, points were selected so that lines connecting them passed close to the center of the picture and that the points were far apart, practically in opposite corners.

■ 46. MOSAIC.—A mosaic consists of several overlapping vertical photographs joined together. When these photographs are oriented with respect to each other by matching detail in the overlap or along the border, the result is an uncontrolled mosaic which gives a good pictorial effect of the ground but may contain considerable errors in scale and direction. When the several photographs are oriented by means of points along the line of flight and adjusted on previously selected ground points, the result is a controlled mosaic. The controlled mosaic is more accurate and for many purposes is as useful as a map. When several photographs taken from a single airplane flight are joined, the result is a strip mosaic. Strip mosaics are commonly used in the early stages of combat as they are quickly made and give a fairly accurate representation of a more or less extended but narrow section of the terrain.

■ 47. PHOTOMAP.—The term photomap is used as a general term to denote reproductions of vertical aerial photographs, composites, or aerial mosaics. On maps and aerial photographs or photomaps for military usage, roads, railroads, towns, streams, wooded and open areas, and relief are of main interest. Relief is not apparent on any photographs unless there is an overlapping pair that can be seen stereoscopically or unless the photograph is ridge lined and stream lined as described in paragraph 29. Figure 64 is a reproduction of a photomap of about the type which may be expected in the

PHOTO MAP

WAR DEPARTMENT
CORPS OF ENGINEERS, U. S. ARMY

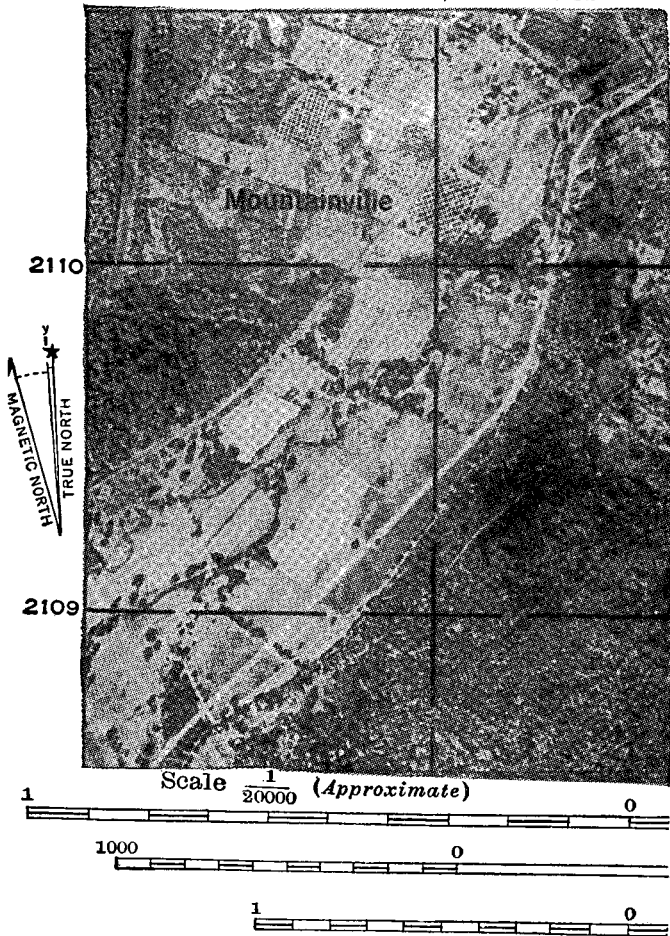

WEST POINT AND VICINITY

FIGURE 64.—Photomap.

field. Although at first glance this photomap appears somewhat indistinct and blurred, those important features referred to above can be seen easily. For example, there is a fairly open valley running from the lower left-hand corner to the upper right-hand corner. There is a stream meandering up the center of this valley. A main highway with several secondary roads runs along its southeastern edge. A railroad, readily identified by means of its long tangents and gradual curves, runs along the northwestern edge of the valley. Several orchards in the vicinity of the town of Mountainville can be picked out. Thus it may be seen that the works of man and changes in wooded and cleared areas are easily seen on a photomap. These are the factors that tend to make a map out of date. The relief as shown on old maps will still be accurate as the ground forms change very slowly. Therefore an up-to-date photomap with any topographic map, whether up to date or not, will give reliable information to the map reader.

■ 48. STEREOVISION.—*a. General.*—The ordinary photograph, as mentioned in paragraph 41, has a flat appearance, which makes it difficult to distinguish between hills and valleys. If two overlapping photographs, known as a stereopair, are viewed either with the naked eyes or with some type of stereoscopic instrument, the effect of depth or relief will be seen and ability had to recognize the actual ground forms. This type of study gives valuable training in understanding and reading both single vertical photographs and photomaps. Consequently, all military personnel should learn and practice stereovision. There are several methods that will assist in acquiring this ability and each individual should experiment until he finds the method that gives him the best results. This ability comes very quickly to most; others will have to use patience and perseverance to obtain it. Experience with large groups of men reveals that anyone with good enough eyes to be in the Army can acquire the ability to see stereoscopically. Stereo studies properly done put no strain on the eyes, and some oculists even prescribe similar exercises to strengthen the eyes. However, when using magnifying spectacles, they should be removed from the eyes before looking up from the photographs.

b. Anaglyph.—Beginners in stereo studies often have difficulty in getting the effect of relief by means of aerial photographs. A simple method of illustrating stereovision is by means of the anaglyph. The anaglyph consists of two different photographs of the same area printed on the same sheet but slightly offset. One is printed in red and the other in blue or green. Relief can be seen when this anaglyph is viewed through a pair of colored spectacles. If the spectacles are reversed or the print is turned upside down, the relief is reversed and ridges will appear as valleys and valleys as ridges. The anaglyph has no practical military value and is used as a quick aid to beginners to illustrate the effects to be obtained by practice in stereovision. For an illustration of an anaglyph see TM 5-230.

APPENDIX

LIST OF REFERENCES

■ 1. MAPS AND MAPPING.—*a.* General publications covering coordination of military maps and mapping:

AR 300-15, Military Maps and Mapping.

FM 30-20, Military Intelligence, Military Maps.

FM 30-21, Military Intelligence, Role of Aerial Photography.

b. Publications of a general nature pertaining to maps and mapping:

FM 21-26, Advanced Map and Aerial Photograph Reading. (Now published as TM 2180-5.)

FM 21-30, Conventional Signs.

FM 21-35, Sketching.

■ 2. CORPS OF ENGINEERS.—Publications pertaining to Corps of Engineers in performance of their mapping duties:

FM 5-5, Engineer Troops.

TM 5-230, Topographic Drafting.

TM 5-235, Surveying.

TM 5-236, Surveying Tables.

TM 5-240, Aerial Photographic Mapping. (Now published as TR 190-27.)

TM 5-245, Map Reproduction in the Field. (Now published as TM 2180-37.)

TM 5-300, Symbols for Seacoast Defense, Fire-Control Maps, Diagrams, and Structures. (Now published as TR 1050-5.)

■ 3. OTHER ARMS.—Publications pertaining to duties of other arms in reference to military maps and mapping:

FM 1-30, Air Navigation.

FM 1-35, Aerial Photography.

TM 1-220, Aerial Photography.

TM 6-200, Field Artillery Survey.

INDEX

	Paragraphs	Pages
Aerial photographs:		
Atlas grid	44	88
Identifying features	42	81
Marginal data	39	70
Oblique	40	72
Orientation	43	86
Type	39	70
Vertical	41	77
Anaglyphs	48	94
Atlas grid	44	88
Azimuth:		
Back	15	20
Grid	15	20
Measuring	18	26
Magnetic	15	20
Plotting	19	27
Type	15	20
Bearing	16	24
Compass:		
Lensatic	38	63
Measuring azimuths	38	63
Prismatic	38	63
Type	38	63
Use at night	38	63
Watch	11	15
Contours	26	36
Characteristics	26	36
Determining elevations	27	42
Emphasizing	29	46
Logical	26	36
Conventional signs	6	3
Coordinates	21	29
Grid	23	31
Polar	22	29
Scale	24	33
Declination	14	19
Grid	14	19
Magnetic	14	19
Use	14	19
Direction	11	15
Angular	12	15
Base	13	17
Distance	9-37	12, 63
Along irregular lines	9	12
Between two points	9	12
Conversion of march time to	10	14
Elevation:		
Determination from contours	27	42
Means of representing	25	35
Finding position by:		
Inspection	35	59
Resection	35	59
Striding or estimation	35	59
Grades	30	48

ELEMENTARY MAP AND AERIAL PHOTOGRAPH READING

	Paragraphs	Pages
Ground forms:		
Representation by hachures -----	28	46
Representation by contours -----	26	36
Ridge lining and stream lining -----	29	46
Hachures -----	28	46
Location:		
Coordinates -----	21	29
Intersection -----	20	27
Position on map -----	34	54
Resection -----	20	27
Maps:		
Battle -----	4	2
Classification -----	5	2
Scale -----	8	11
Substitutes -----	4, 41, 46, 47	2, 77, 92
Map orientation:		
Compass -----	34	54
Distant points -----	34	54
Inspection -----	34	54
Map reading -----	33	54
Military symbols -----	7	7
Mosaics -----	46	92
Oblique -----	40	72
Orientation of maps. <i>See</i> Map orientation.		
Photomaps -----	47	92
Profiles:		
Drawing -----	31	49
Hasty -----	32	51
Vertical scale -----	31	51
Rates of march -----	10	14
Relief:		
Contours -----	26	36
Ridge lining and stream lining -----	29	46
Representative fraction -----	8	11
Resection -----	35	59
Ridge lining and stream lining -----	29	46
Scales:		
Map:		
Coordinates -----	24	33
Graphic -----	8	11
Photograph:		
Focal length and altitude -----	45	90
Map or ground distance -----	45	90
Slopes -----	30	48
Stereovision -----	48	94
Anaglyphs -----	48	94
Terrain features, military terms -----	36	61
Time measurement:		
Distance to march time -----	10	14
March time to distance -----	10	14
Vertical photographs -----	41	77
Visibility:		
Hasty profile -----	32	51
Inspection -----	32	51
Profile -----	32	51





FIG. 1

Prepared under the direction of the Chief of Engineers, U. S. Army, 1939.
Control by U. S. Coast and Geodetic Survey, 1924 and 1935, U. S.
Geological Survey, 1912 and 1934 and 29th Engineers, U. S. Army, 1937-38.
Topography by 29th Engineers, U. S. Army, 1939, using multiplex aero
projectors, T-3 A (five-lens) photography by 91st Observation Squadron,
Air Corps, U. S. Army, 1938.
Polyconic Projection, North American Datum 1927.

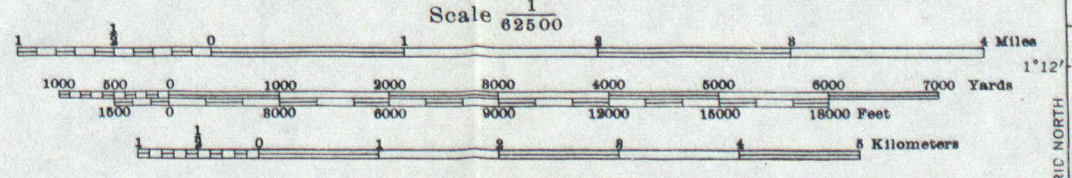

Scale 1:62500
Contours interval 20 feet
Datum is mean sea level (1929 Adj.)

FIVE THOUSAND YARD GRID COMPUTED FROM "GRID SYSTEM FOR PROGRESSIVE MAPS
IN THE U. S." ZONE G, U. S. C. A. G. S. SPECIAL PUBLICATION NO. 59
(THE LAST THREE DIGITS OF THE GRID NUMBERS ARE OMITTED.)

NOTE: OFFICERS USING THIS MAP WILL MAKE HEREON CORRECTIONS AND ADDITIONS WHICH COME
TO THEIR ATTENTION AND MAIL DIRECT TO "THE CHIEF OF ENGINEERS, WASHINGTON, D. C."



FIGURE 2. MEDIUM SCALE MAP

ROUTES USUALLY TRAVELED
HARD IMPROVED SURFACES
OTHER SURFACE IMPROVEMENTS
U. S. ROUTE
STATE ROUTE

APPROX. MEAN DECLINATION 1937
ANNUAL MAG. CHANGE 2" DECREASE

(Tacoma 1:62500)
(Chehalis 1:125000)

(Tacoma 1:62500)
(Tacoma South 1:62500)
(Tacoma Lake 1:62500)
(Edmonds 1:125000)

Woods  Cut-over areas 

GRID ZONE "G"

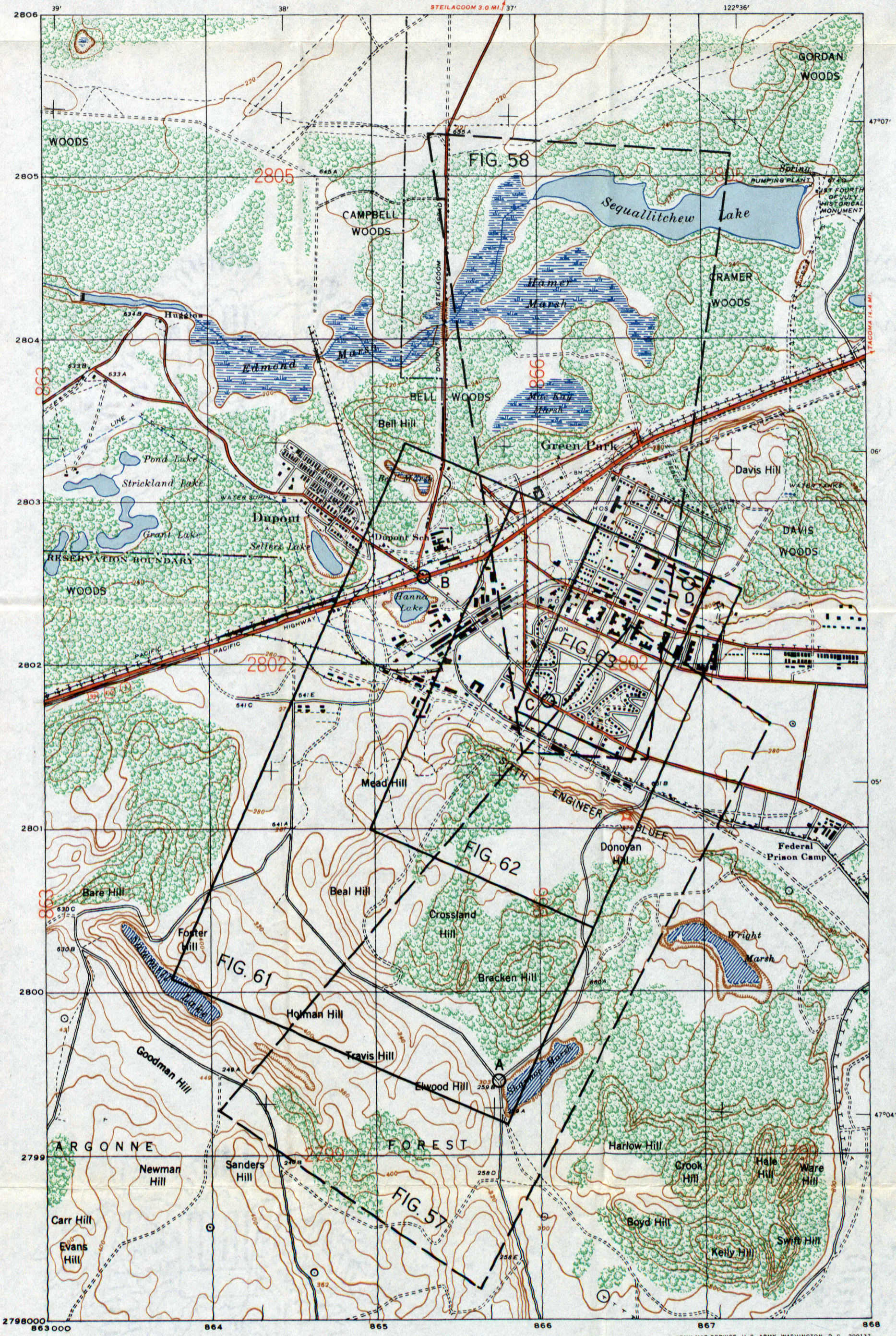

Scale $\frac{1}{20000}$

ARMY MAP SERVICE, U. S. ARMY, WASHINGTON, D. C. 200137

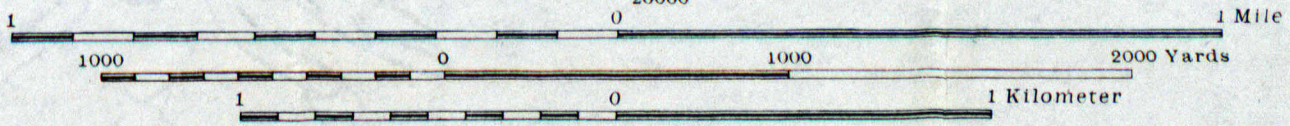

Datum is mean sea level (1929 Gen. Adj.)

ONE THOUSAND YARD GRID COMPUTED FROM "GRID SYSTEM FOR PROGRESSIVE MAPS IN THE U. S. ZONE G, U. S. C. & G. S. SPECIAL PUBLICATION NO. 59"

NOTE: OFFICERS USING THIS MAP WILL MARK HEREON CORRECTIONS AND ADDITIONS WHICH COME TO THEIR ATTENTION AND MAIL DIRECT TO "THE CHIEF OF ENGINEERS, WASHINGTON, D. C."

FIGURE 1. LARGE SCALE MAP

Prepared under the direction of the Chief of Engineers, U. S. Army, 1939.
 Control by U. S. Coast and Geodetic Survey, 1924 to 1935, U. S. Geological Survey, 1912 to 1934 and 29th Engineers, U. S. Army, 1937-38.
 Topography by 29th Engineers, U. S. Army, 1939, using Multiplex Aero Projectors.
 T3-A (5 lens) photography by 91st Observation Squadron, Air Corps, U. S. Army, 1938.
 Polyconic Projection, North American Datum 1927.

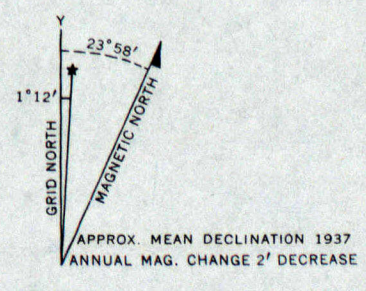

ROUTES USUALLY TRAVELED
 HARD IMPROVED SURFACES
 OTHER SURFACE IMPROVEMENTS
 1940
 3 U. S. ROUTE 73 STATE ROUTE