

Process switches and relay circuits

This worksheet and all related files are licensed under the Creative Commons Attribution License, version 1.0. To view a copy of this license, visit <http://creativecommons.org/licenses/by/1.0/>, or send a letter to Creative Commons, 559 Nathan Abbott Way, Stanford, California 94305, USA. The terms and conditions of this license allow for free copying, distribution, and/or modification of all licensed works by the general public.

Questions

Question 1

Switches, whether they be hand-actuated or actuated by a physical process, come in two varieties: *normally-open* (NO) and *normally-closed* (NC). You are probably accustomed to seeing both types of switch represented in pushbutton form on schematic diagrams:

Normally-open
pushbutton switch

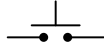

Normally-closed
pushbutton switch



Normally-open pushbutton switches close (pass current) when actuated (pressed). When un-actuated, they return to their “normal” (open) state.

Normally-closed pushbutton switches are just the opposite: they open (stop current) when actuated (pressed) and return to their “normal” (closed, passing current) state when un-actuated.

This is simple enough to comprehend: the “normal” status of a momentary-contact pushbutton switch is the state it is in when no one is touching it. When pressed, the pushbutton switch goes to the other (opposite) state.

Things get more confusing, though, when we examine *process switches*, such as pressure switches, level switches, temperature switches, and flow switches:

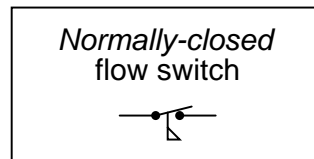
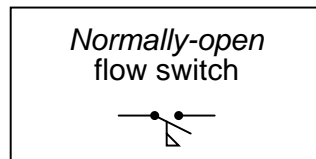
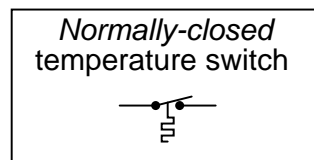
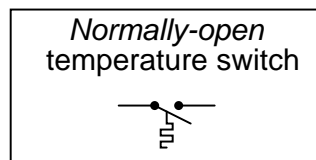
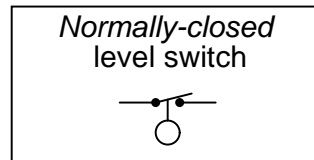
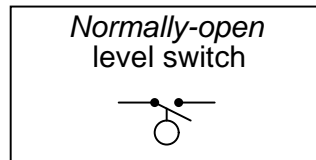
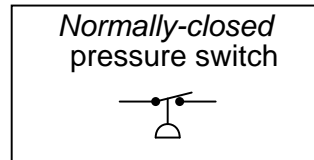
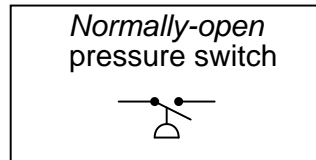

Define “normal” for each of these process switches. In other words, explain what condition(s) each process switch must be in to ensure it is in the “normal” state; and conversely, what condition(s) need to be applied to each switch to force it into its other state.

[file i02966](#)

Question 2

Limit switches are electrical switches designed to actuate based on the motion or position of an object, rather than the touch of a human operator. Simple limit switches rely on direct, physical contact, using a lever, sometimes tipped with a roller for low friction:

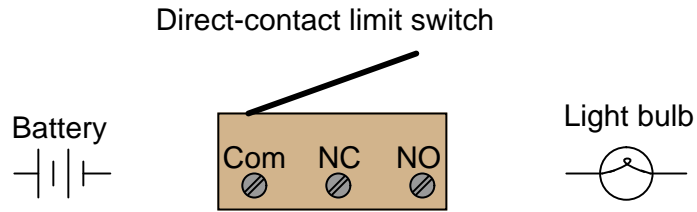

Show how you would connect the limit switch in the above illustration so that it makes the light turn *off* when actuated (i.e. the light will be on when no one touches the switch lever).

[file i02242](#)

Question 3

An improvement over direct-contact limit switches for many applications is the *inductive proximity switch*. This type of switch actuates simply when an object gets *near* it – no direct physical contact necessary! Explain how these devices work, and what kinds of material they are able to detect.

Inductive proximity switches are powered devices by necessity. They usually require a DC voltage for power, and their output is usually *not* a dry switch contact. Instead, it is usually a transistor, with the output signal being standard TTL logic (0 to 5 volts). Inductive proximity switches are often manufactured as three-wire devices:

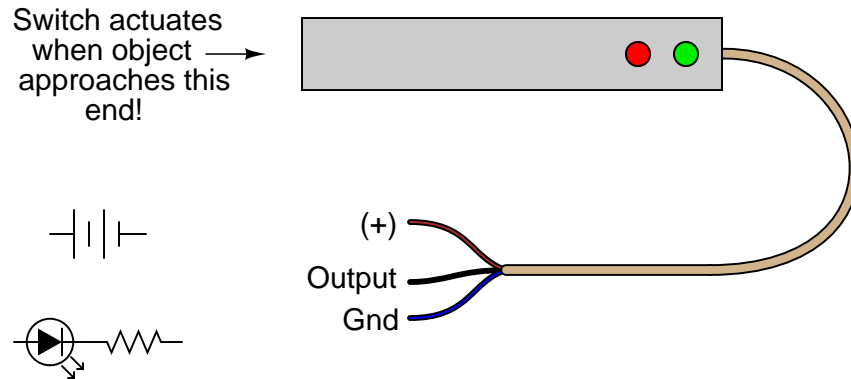

Show how you would connect the limit switch in the above illustration so that it makes the LED turn *on* when actuated, assuming the switch's internal transistor is configured to *source* current through the output lead.

Suggestions for Socratic discussion

- Identify an object a capacitive proximity switch would be able to detect.
- Identify an object an ultrasonic proximity switch would be able to detect.
- Identify an object an inductive proximity switch would *not* be able to detect.
- Identify an object an optical proximity switch would *not* be able to detect.

[file i02243](#)

Question 4

An improvement over direct-contact limit switches for many applications is the *inductive proximity switch*. This type of switch actuates simply when an object gets *near* it – no direct physical contact necessary! Explain how these devices work, and what kinds of material they are able to detect.

Inductive proximity switches are powered devices by necessity. They usually require a DC voltage for power, and their output is usually *not* a dry switch contact. Instead, it is usually a transistor, with the output signal being standard TTL logic (0 to 5 volts). Inductive proximity switches are often manufactured as three-wire devices:

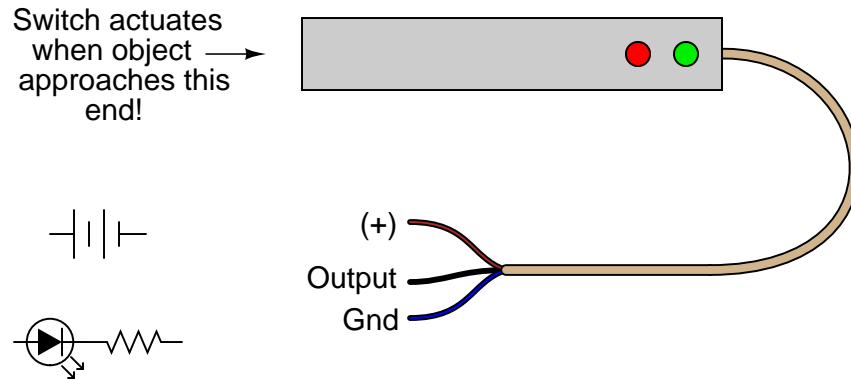

Show how you would connect the limit switch in the above illustration so that it makes the LED turn *on* when actuated, assuming the switch's internal transistor is configured to *sink* current through the output lead.

Suggestions for Socratic discussion

- Identify an object an inductive proximity switch would be able to detect.
- Identify an object an optical proximity switch would be able to detect.
- Identify an object a capacitive proximity switch would *not* be able to detect.
- Identify an object an ultrasonic proximity switch would *not* be able to detect.

[file i02244](#)

Question 5

An alternative to the conventional schematic diagram in AC power control systems is the *ladder diagram*. In this convention, the “hot” and “neutral” power conductors are drawn as vertical lines near the edges of the page, with all loads and switch contacts drawn between those lines like rungs on a ladder:

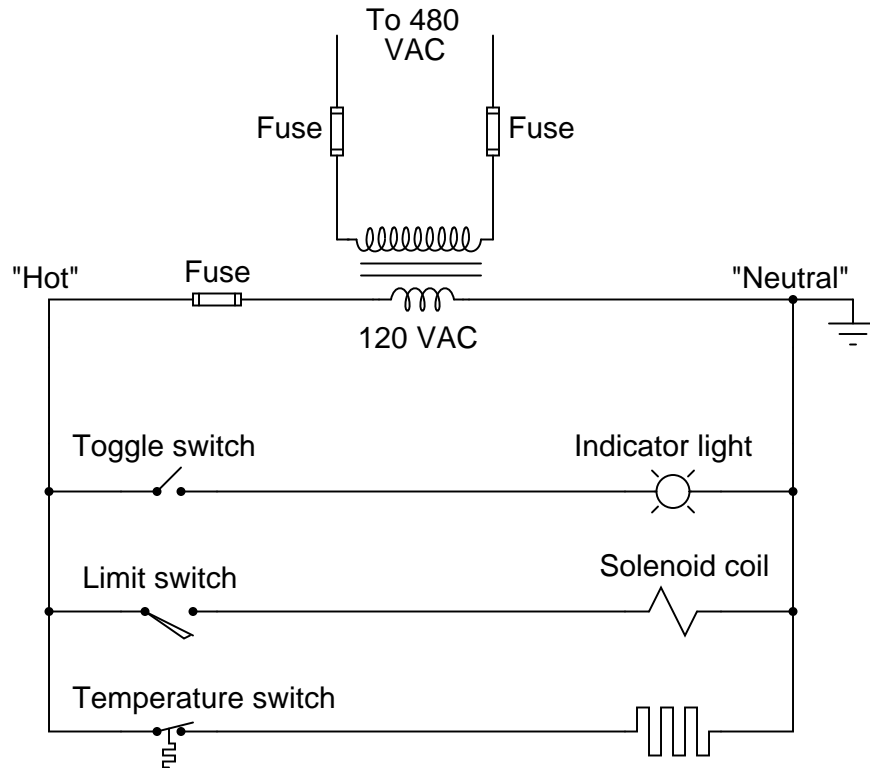

As you can see, the symbolism in ladder diagrams is not always the same as in electrical schematic diagrams. While some symbols are identical (the toggle switch, for instance), other symbols are not (the solenoid coil, for instance).

Re-draw this ladder diagram as a schematic diagram, translating all the symbols into those correct for schematic diagrams.

[file i02302](#)

Question 6

Explain what the following “ladder-logic” circuit does, and identify the meaning of each symbol in the diagram:

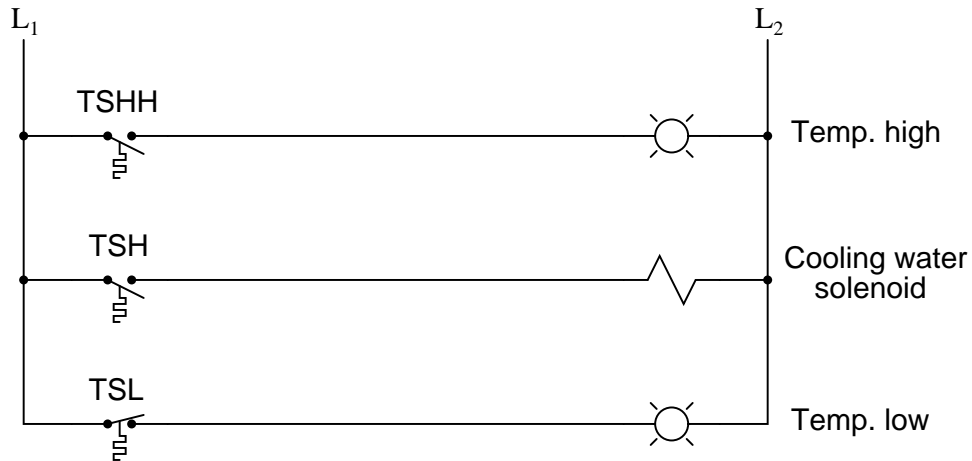

Suggestions for Socratic discussion

- Explain why the TSH uses a *normally-open* contact instead of a *normally-closed* contact.
- Explain why the TSL uses a *normally-closed* contact instead of a *normally-open* contact.
- Based on what we see in this diagram, determine whether the electric solenoid valve allows cooling water to flow when energized, or when de-energized.
- What do the designations “L1” and “L2” refer to in ladder-logic electrical diagrams?
- Suppose switch TSL has a trip setting of 105 °F (falling) and a deadband value of 2 °F. Explain how this switch will respond to a rising and falling temperature.
- Suppose we wished to have switch TSHH activate *two* different alarm lights instead of just one. Modify the circuit diagram accordingly.

[file i00364](#)

Question 7

Identify which lamp in the following ladder-logic diagram is the *high-flow* alarm and which is the *low-flow* alarm, given the flow switch symbols shown:

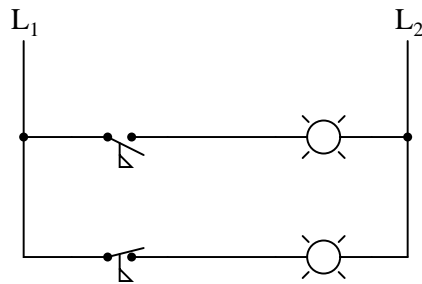

[file i00548](#)

Question 8

Limit switches are often used on the doors of electrical enclosures and cabinets to automatically shut off power or shut down a machine's function if anyone opens the door for maintenance purposes. The limit switch is typically mounted in such a way that a shut door holds the switch lever in the "actuated" position. When the door opens wide, the limit switch lever is released and the switch returns to its "normal" status.

Draw the appropriate limit switch symbol in this ladder logic diagram so that the control circuit (shown as a rectangular box) gets shut down if ever someone opens the cabinet door:

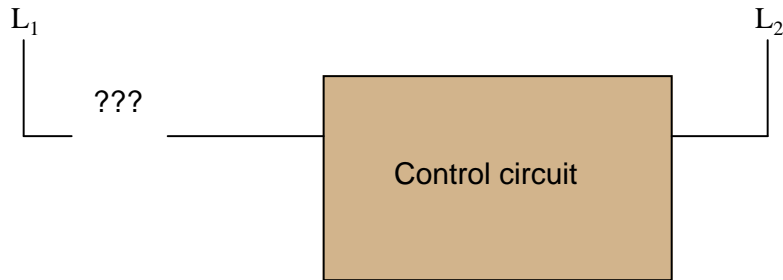

Be sure to denote whether this limit switch needs to be normally-open (N.O.) or normally-closed (N.C.).
[file i02967](#)

Question 9

Determine the functions of all pressure switches and relays in this steam boiler monitoring circuit, and what each of their designations mean:

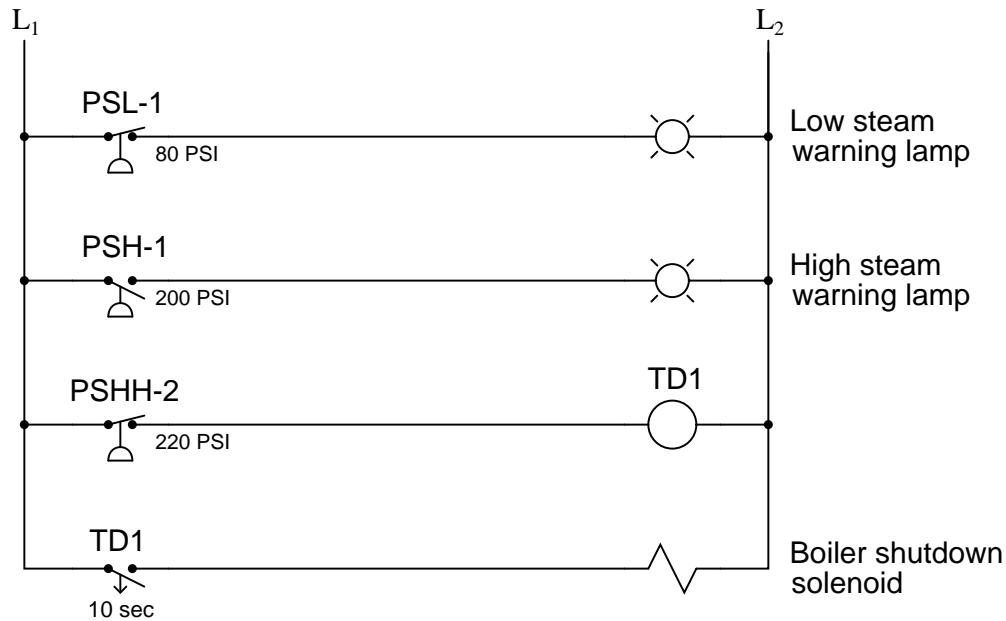

Also, explain the significance of the switch symbols: normally open versus normally closed. The time-delay relay (TD1) is especially important here!

Finally, add a “Lamp Test” pushbutton switch to this circuit which will force all lamps to energize when pressed, in order to test the proper operation of the lamps without waiting for an abnormal process condition to occur.

Suggestions for Socratic discussion

- Why do you suppose a time-delay relay is used in this particular control application?
- Is the boiler shutdown solenoid *energize-to-trip* or *de-energize-to-trip*? Explain how we can tell from an examination of the schematic.
- Identify where in this circuit you could install a PSHHH (pressure switch high-high-high) that would trip the boiler immediately.
- Identify a circuit fault that would cause the boiler to needlessly shut down (a “safe” fault).
- Identify a circuit fault that would cause the boiler to not be able to shut down when it needs to (a “dangerous” fault).

file i00221

Question 10

Two pressure switches are plumbed together so as to receive the exact same pressure at all times, and they both sense the pressure of compressed air in a pneumatic system. Based on the wiring diagram for these switches, identify the function of the lamp:

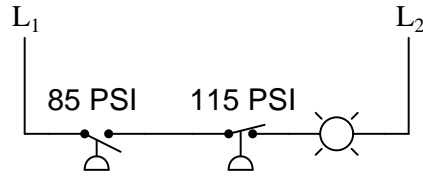

[file i02964](#)

Question 11

Draw the appropriate pressure switch symbol in this ladder-logic diagram for a *low-pressure alarm* which turns on a lamp if the oil pressure of an industrial machine ever drops below 10 PSI:

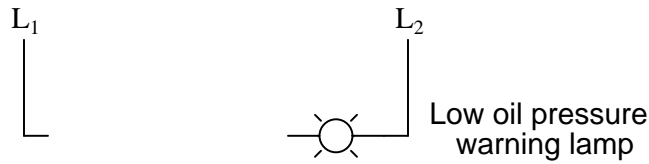

Be sure to specify whether the pressure switch needs to be *normally-open* (NO) or *normally-closed* (NC).
[file i02965](#)

Question 12

Determine the statuses of all lamps and relay coils in this circuit, given the following process conditions:

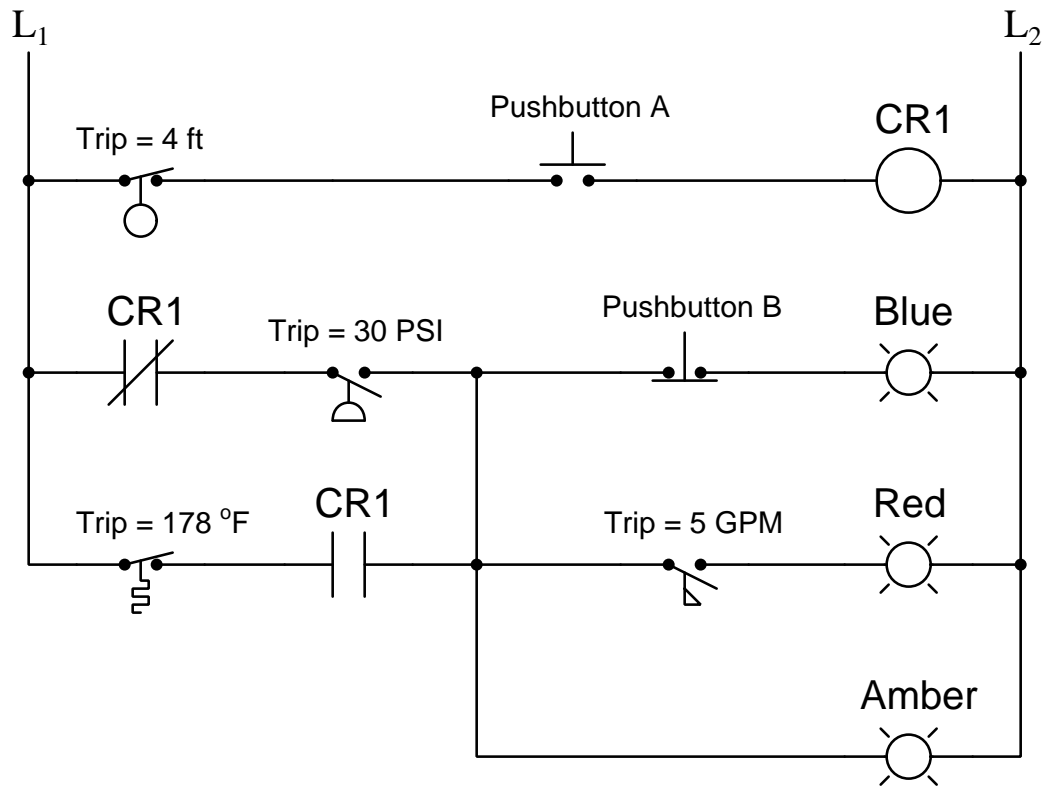

- Flow = 3.5 GPM
- Pressure = 41 PSI
- Temperature = 155 °F
- Level = 1.3 ft
- Pushbutton A = *unpressed*
- Pushbutton B = *unpressed*

file i01087

Question 13

Determine the statuses of all lamps and relay coils in this circuit, given the following process conditions:

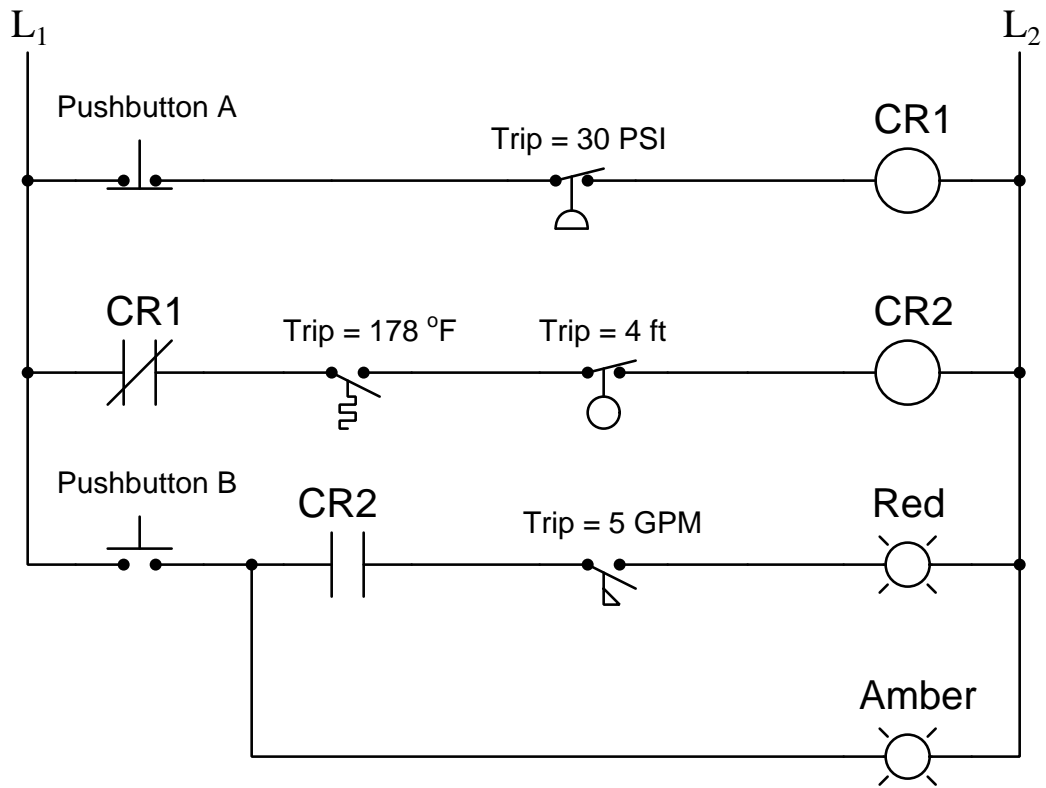

- Flow = 4 GPM
- Pressure = 24 PSI
- Temperature = 190 °F
- Level = 2.5 ft
- Pushbutton A = *pressed*
- Pushbutton B = *pressed*

[file i01088](#)

Question 14

Determine the statuses of all lamps and relay coils in this circuit, given the following process conditions:

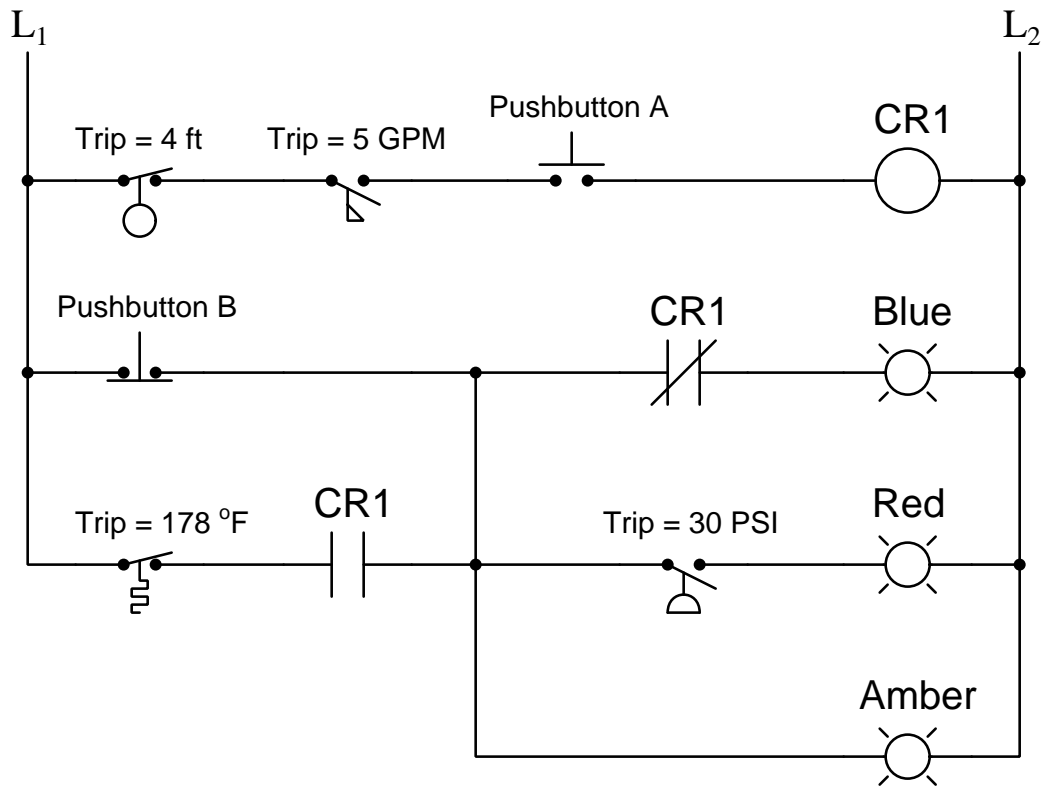

- Flow = 7.9 GPM
- Pressure = 36 PSI
- Temperature = 210 °F
- Level = 7.1 ft
- Pushbutton A = *pressed*
- Pushbutton B = *unpressed*

file i01089

Question 15

Sketch the necessary wiring to make this pressure switch control two lamps in the following manner:

- High process pressure: green lamp on and red lamp off
- Low process pressure: red lamp on and green lamp off

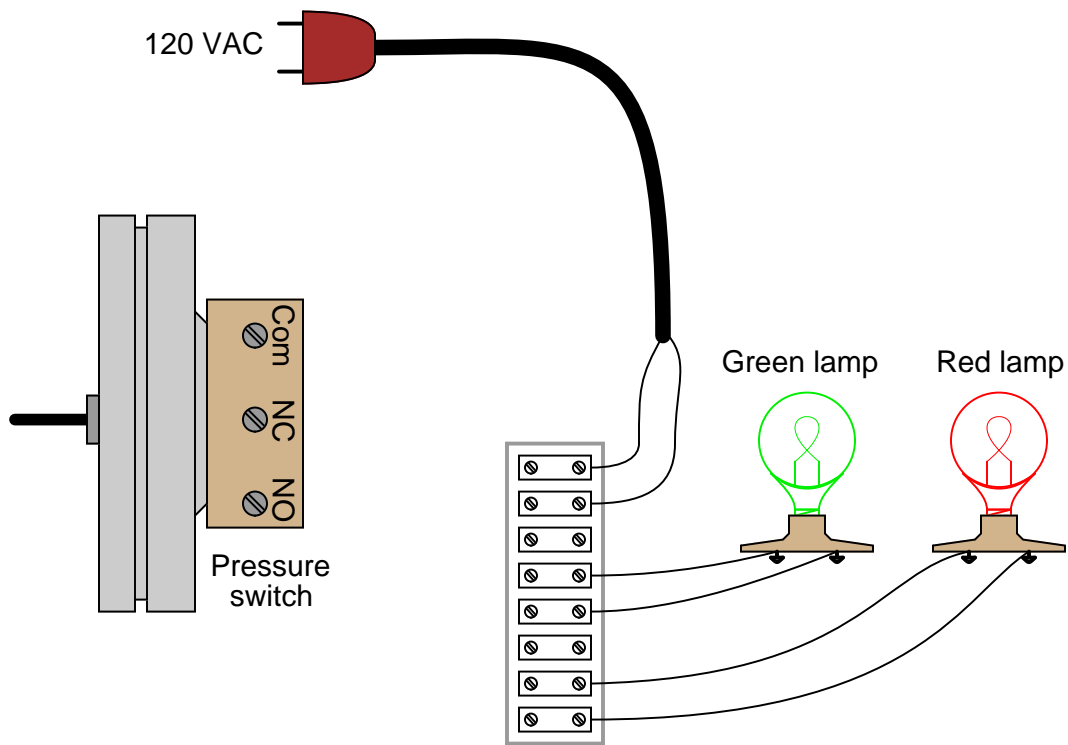

Hint: remember that the “normal” status of a switch is defined as the status of *minimum stimulus*: when the switch is exposed to the lowest possible degree of process stimulation (in this particular case, to the lowest possible pressure).

[file i03251](#)

Question 16

Examine the following electronic level switch circuit:

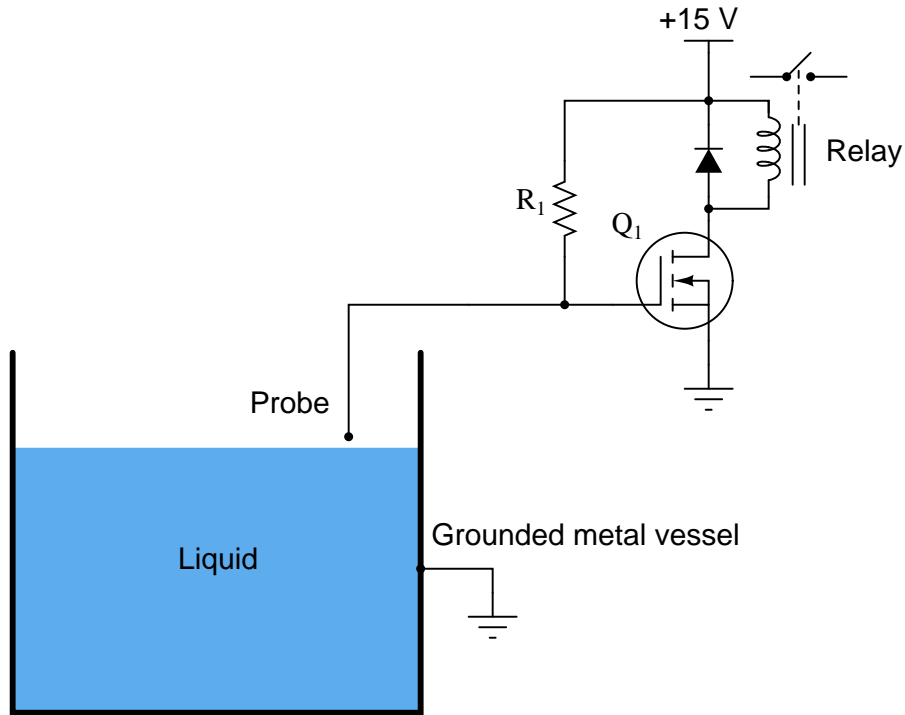

Identify what kinds of process liquids this level switch would be applicable to, and why. Also, identify which ladder-logic switch symbol would be appropriate for this particular level switch:

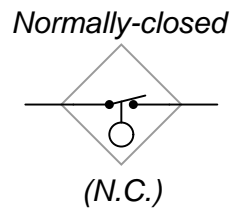
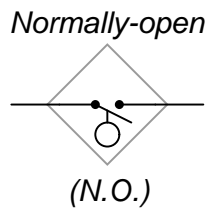

Qualitatively determine the following component voltage drops in the circuit with low level and with high level (i.e. write “low” or “high” voltage rather than try to calculate actual values):

Component	Low-level condition	High-level condition
R_1		
Q_1 (between drain and source)		
Relay coil		

Question 17

Sketch the necessary wiring to make this pressure switch control two lamps in the following manner:

- High process pressure: green lamp off and red lamp off
- Low process pressure: red lamp on and green lamp on

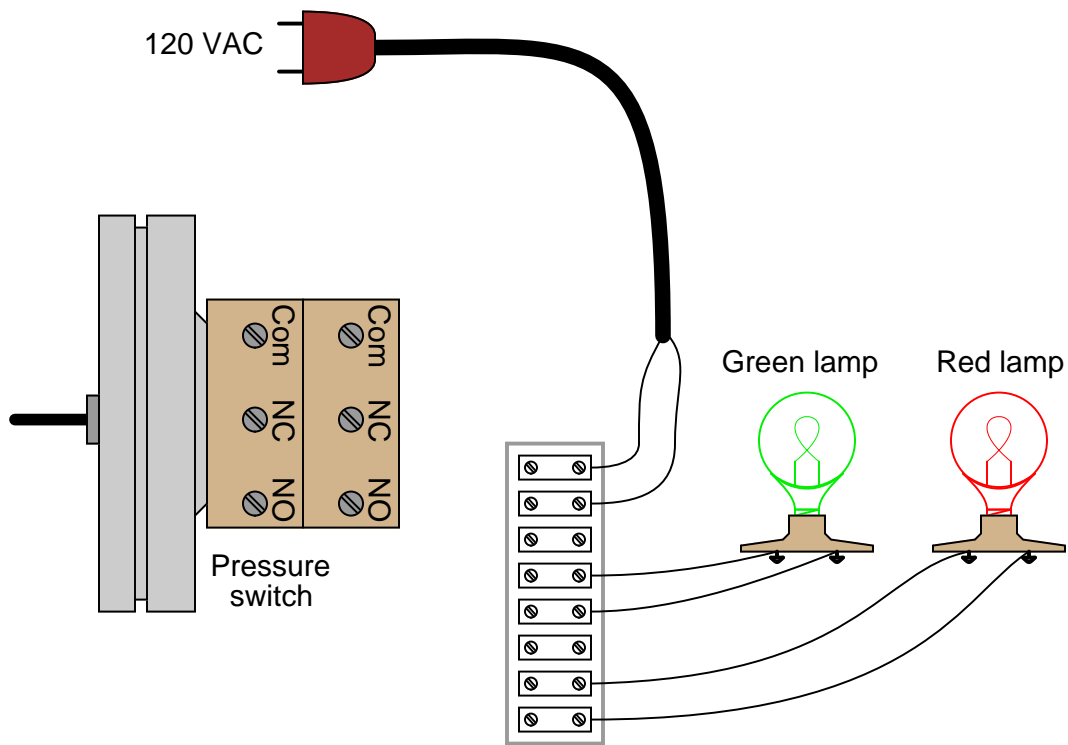

Hint: remember that the “normal” status of a switch is defined as the status of *minimum stimulus*: when the switch is exposed to the lowest possible degree of process stimulation (in this particular case, to the lowest possible pressure).

[file i01972](#)

Question 18

Sketch the necessary wiring to make this float-type level switch control a pump and a lamp in the following manner:

- High liquid level: pump on and lamp off
- Low liquid level: pump off and lamp on

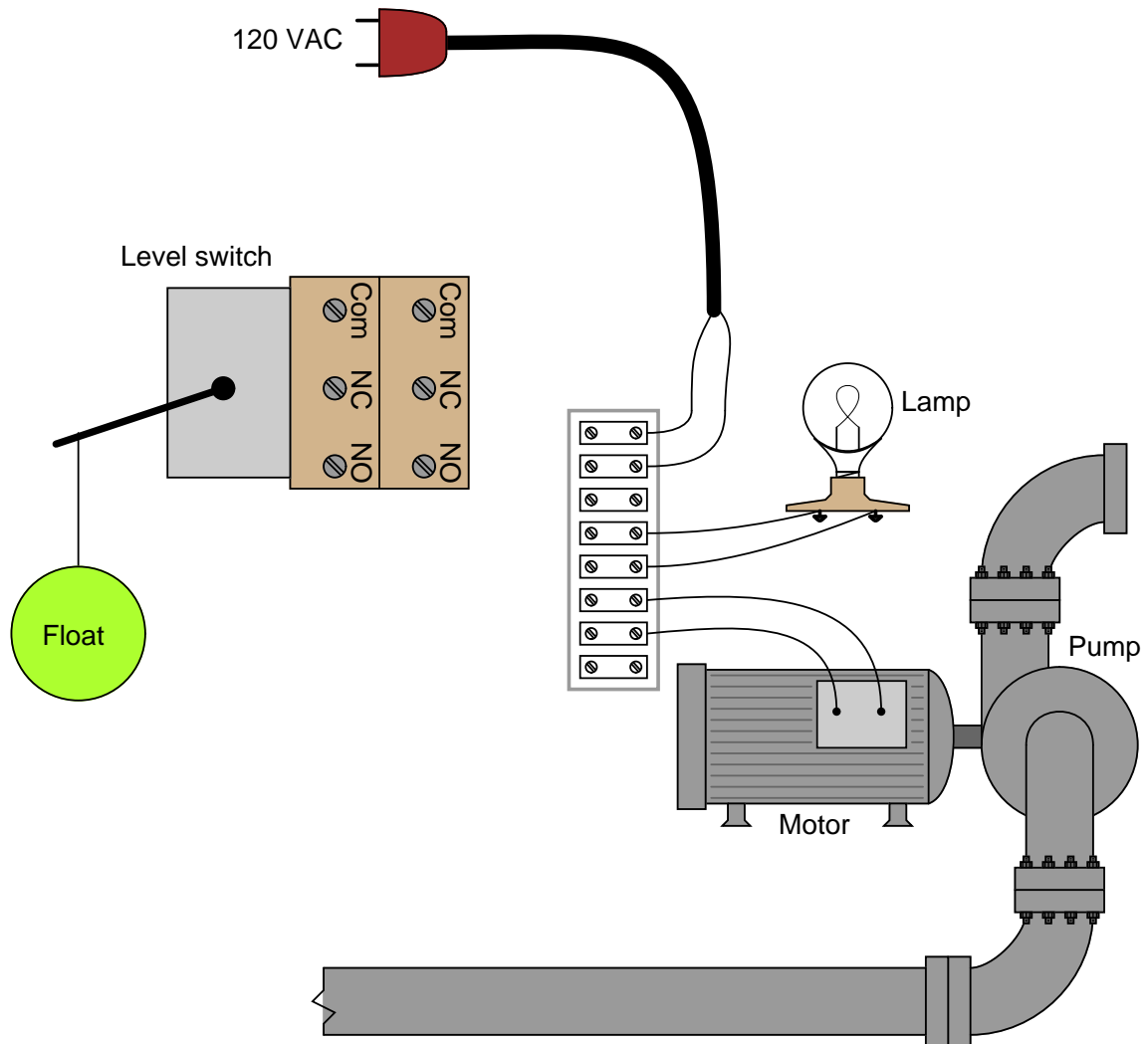

Hint: remember that the “normal” status of a switch is defined as the status of *minimum stimulus*: when the switch is exposed to the lowest possible degree of process stimulation (in this particular case, to the lowest possible level).

[file i01973](#)

Question 19

Explain the operation of this circuit:

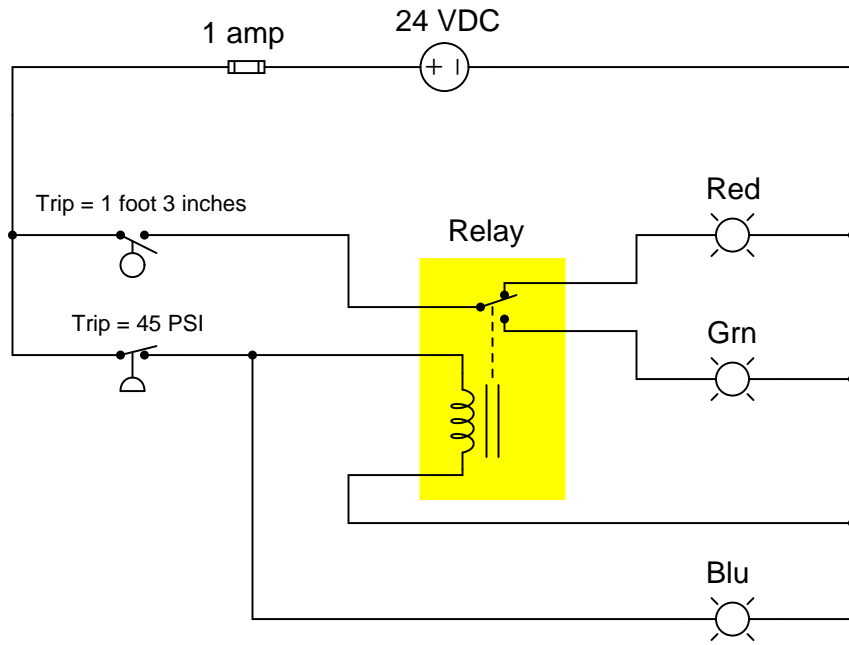

file i02304

Question 20

Some common components of three-phase motor control circuits are shown here in the following illustrations. These include *fuses*, a *contactor*, and an *overload* assembly:

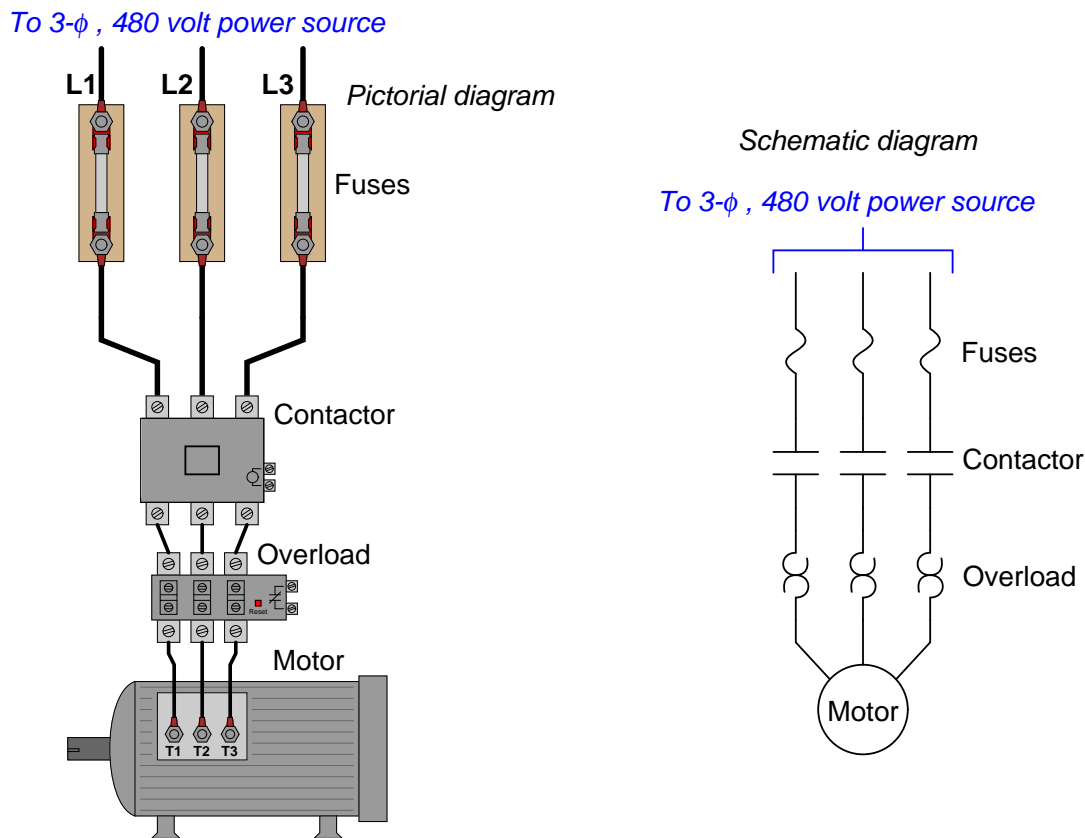

Fuses protect the power wiring from gross overcurrent conditions such as what might happen if there were an accidental phase-to-phase short-circuit inside the motor. The contactor is nothing more than a big relay with three normally-open contacts to send power to the motor, serving to start and stop the motor on command with a 120 volt signal to its coil.

The overload block, however, is a little more mysterious. Its three “heater” elements (looking like back-to-back “question mark” symbols in the schematic diagram) carry the motor’s current from the contactor to the motor terminals. These resistive heaters are designed to become warm under normal operating conditions, just as the motor itself will become slightly warm under normal conditions from resistive power losses in its windings.

If the motor ever becomes too warm as a result of overloading (slight overcurrent), the overload heaters (which will also be too warm due to the overcurrent) will trigger a small thermally-operated switch contact to spring open. Connection terminals for this small switch contact may be seen on the right-hand side of the overload block in the pictorial diagram.

Explain how the overload heaters may be used to automatically shut the motor off and prevent damage.
[file i01444](#)

Question 21

Draw a ladder logic control circuit for the electric motor of an air compressor, controlled by two pressure switches: one switch turns the motor on when the pressure falls to 80 PSI, while the other switch turns the motor off when the pressure rises to 105 PSI:

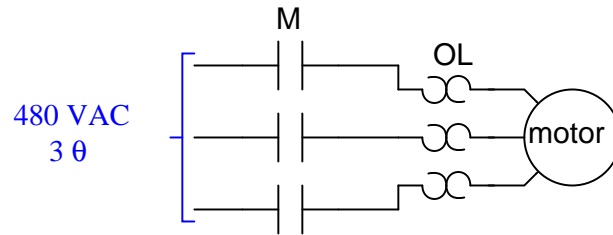

Be sure to include the overload (OL) contact in the 120 volt control circuit (L_1 & L_2), and include a manual on/off switch as well.

[file i00799](#)

Question 22

A form of liquid level switch called a *tilt switch* is often used for detecting sewage level in “lift stations” where sewage collected from homes via gravity is pumped out of the collection sump to the wastewater treatment plant (usually located miles away):

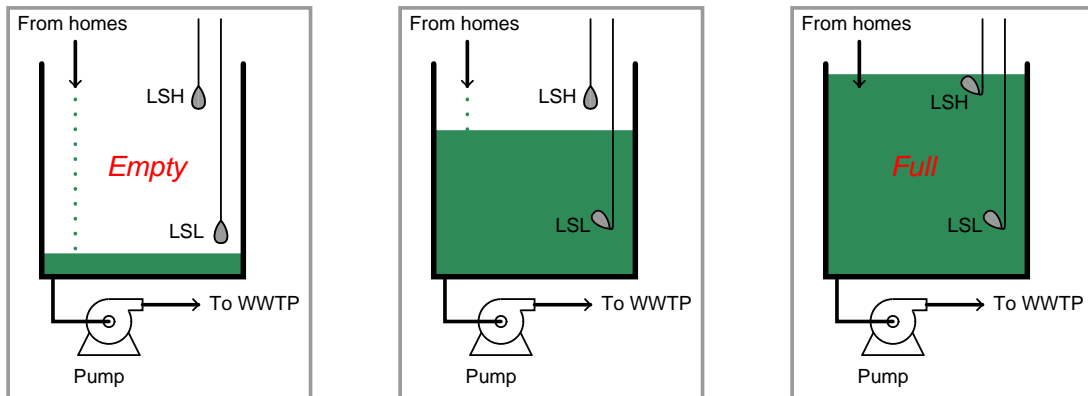

Tilt switches often use a small glass vial containing liquid mercury as the tilt sensor. Explain how a glass tube partially filled with mercury works as an electrical tilt switch, and also perform a “thought experiment” where you describe this system’s function from start to finish through a complete start-stop cycle of the pump motor:

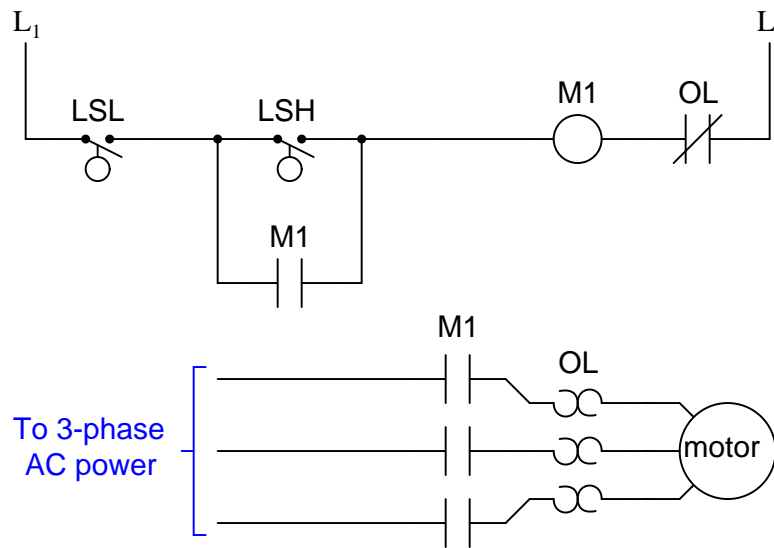

Suggestions for Socratic discussion

- What would happen if the OL switch failed open in this system?
- What would happen if the LSL switch failed open in this system?
- What would happen if the LSH switch failed open in this system?
- What would happen if the LSL switch failed shorted in this system?
- What would happen if the LSH switch failed shorted in this system?
- What would happen if the LSH switch failed shorted in this system?

- What would happen if the M1 seal-in contact failed open in this system?
- What would happen if the M1 seal-in contact failed shorted in this system?

file i00303

Answers

Answer 1

The “normal” condition for a process switch is the condition of *least stimulus*. For example:

- A pressure switch will be in its “normal” state when there is *minimum pressure applied*
- A level switch will be in its “normal” state when there is *no level detected by the switch*
- A temperature switch will be in its “normal” state when it is *cold*
- A flow switch will be in its “normal” state when there is *no flow detected by the switch*

Answer 2

Light bulb turns off when limit switch actuates

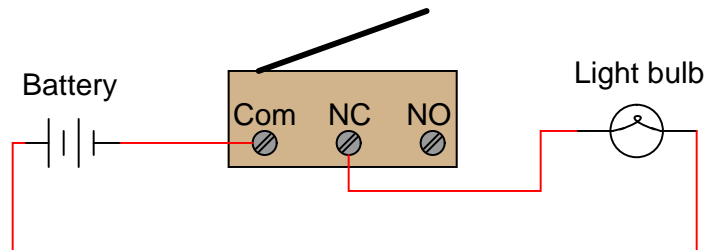

Answer 3

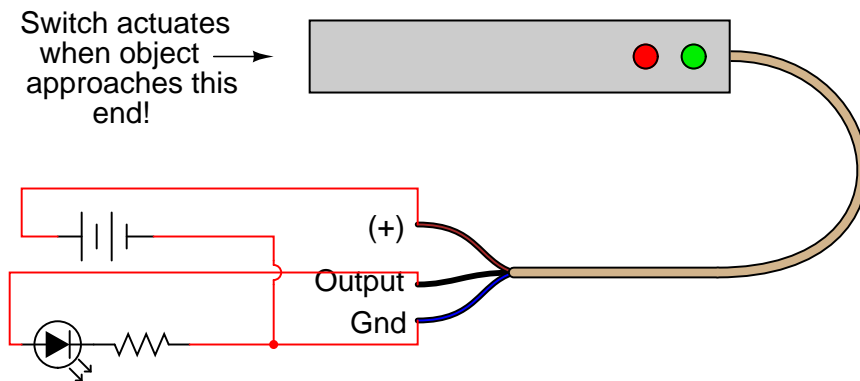

Answer 4

Answer 5

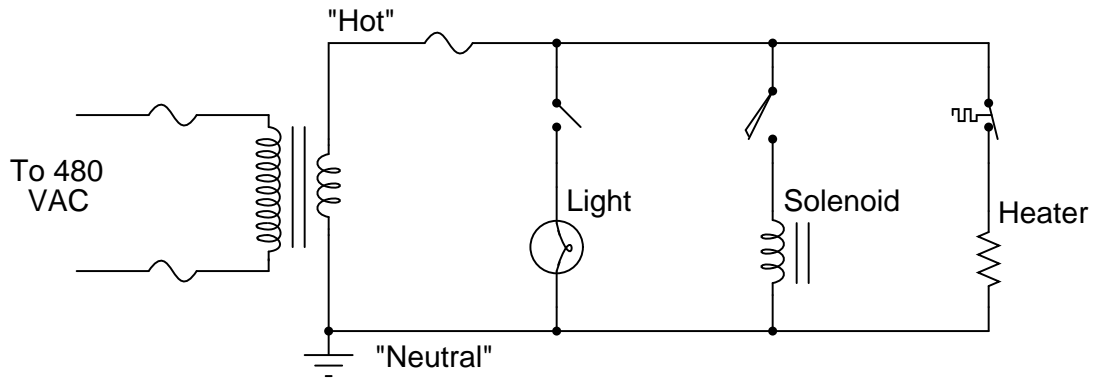

Answer 6

This is an automatic cooling system with high and low temperature alarms.

Answer 7

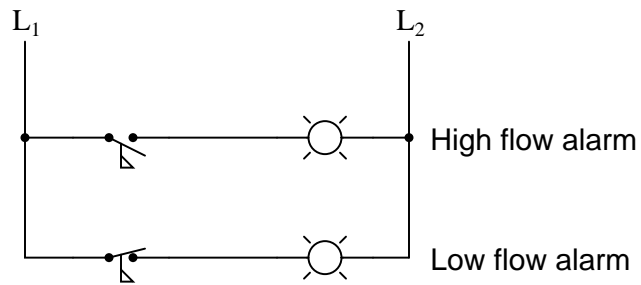

Answer 8

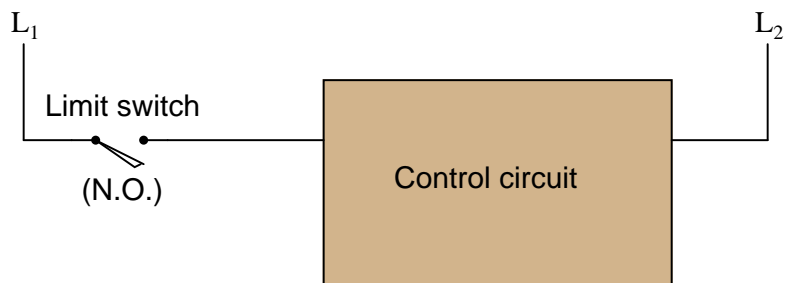

Answer 9

- PSL = Pressure Switch, Low
- PSH = Pressure Switch, High
- PSHH = Pressure Switch, High-High

Both warning lamps should be off when the steam pressure is between 80 and 200 PSI. The boiler will automatically shut down when the shutdown solenoid de-energizes, and this will happen if the steam pressure exceeds 220 PSI for at least 10 seconds.

The difference between a “normally open” process switch and a “normally closed” process switch is vitally important for technicians to understand. The “normal” condition referred to in each label does *not* mean the condition that is typical for the process. Rather, it refers to a condition where the switch is subjected to *minimum stimulus*. In other words, the “normal” condition for each switch is:

- Temperature switch = cold
- Pressure switch = low or no pressure
- Level switch = empty vessel
- Flow switch = low or no flow

Answer 10

The lamp’s illumination signifies a condition where the compressed air pressure is somewhere between 85 and 115 PSI. The lamp will turn off if the pressure drops below 85 PSI *or* if the pressure rises above 115 PSI.

Answer 11

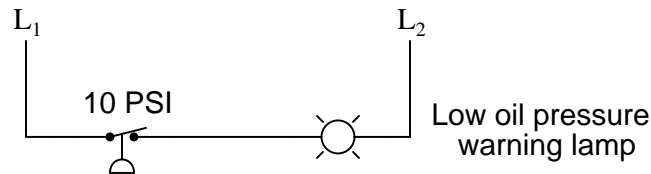

As the diagram shows, this needs to be a **normally-closed** switch.

Fully annotated circuit schematic: “X” representing an open contact or de-energized load, and “→” representing a closed contact or energized load

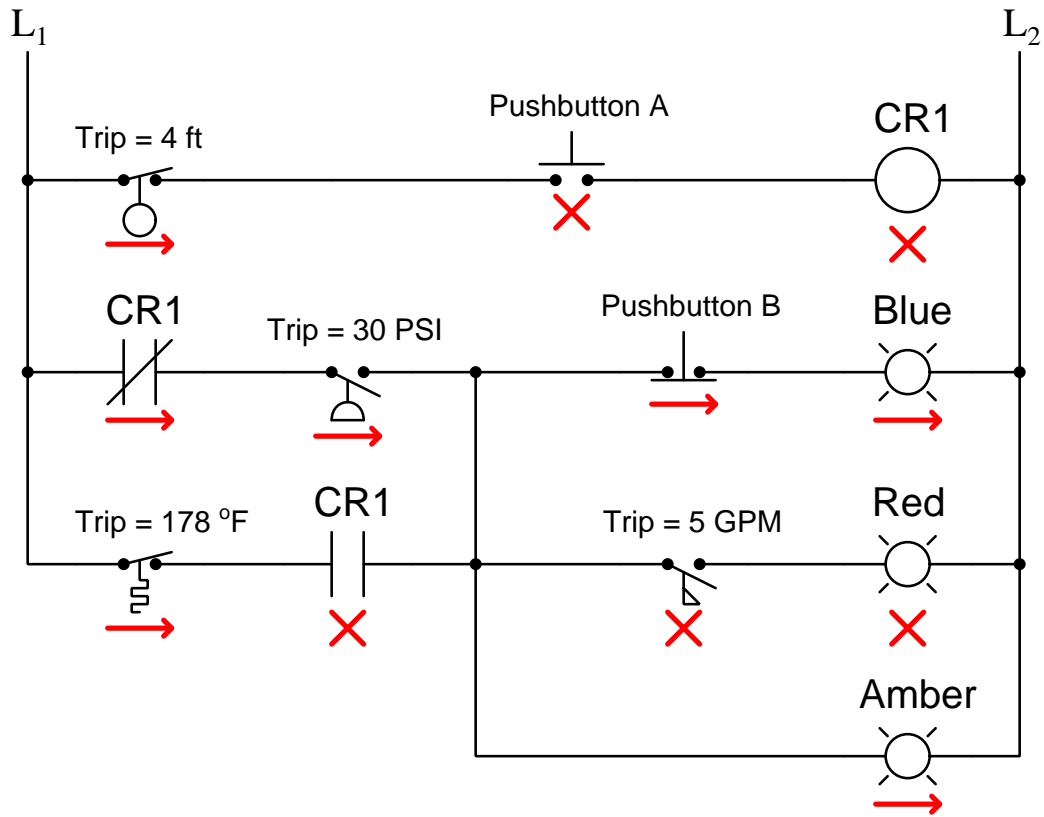

Recall that a process switch will be in its resting (“normal”) condition when the stimulus value is less than the trip threshold, and will be in its actuated condition when the stimulus exceeds the threshold.

Therefore,

- CR1 coil = **de-energized**
- Blue lamp = **energized**
- Red lamp = **de-energized**
- Amber lamp = **energized**

Fully annotated circuit schematic: “X” representing an open contact or de-energized load, and “→” representing a closed contact or energized load

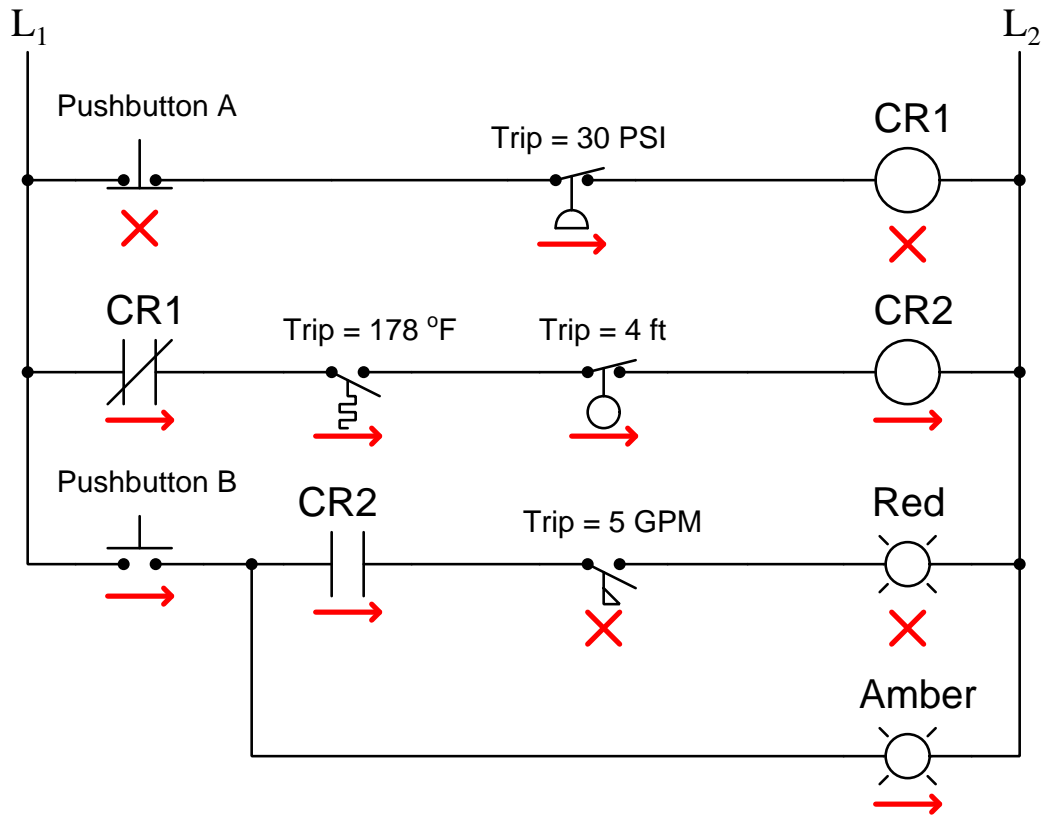

Recall that a process switch will be in its resting (“normal”) condition when the stimulus value is less than the trip threshold, and will be in its actuated condition when the stimulus exceeds the threshold.

Therefore,

- CR1 coil = **de-energized**
- CR2 coil = **energized**
- Red lamp = **de-energized**
- Amber lamp = **energized**

Fully annotated circuit schematic: “X” representing an open contact or de-energized load, and “→” representing a closed contact or energized load

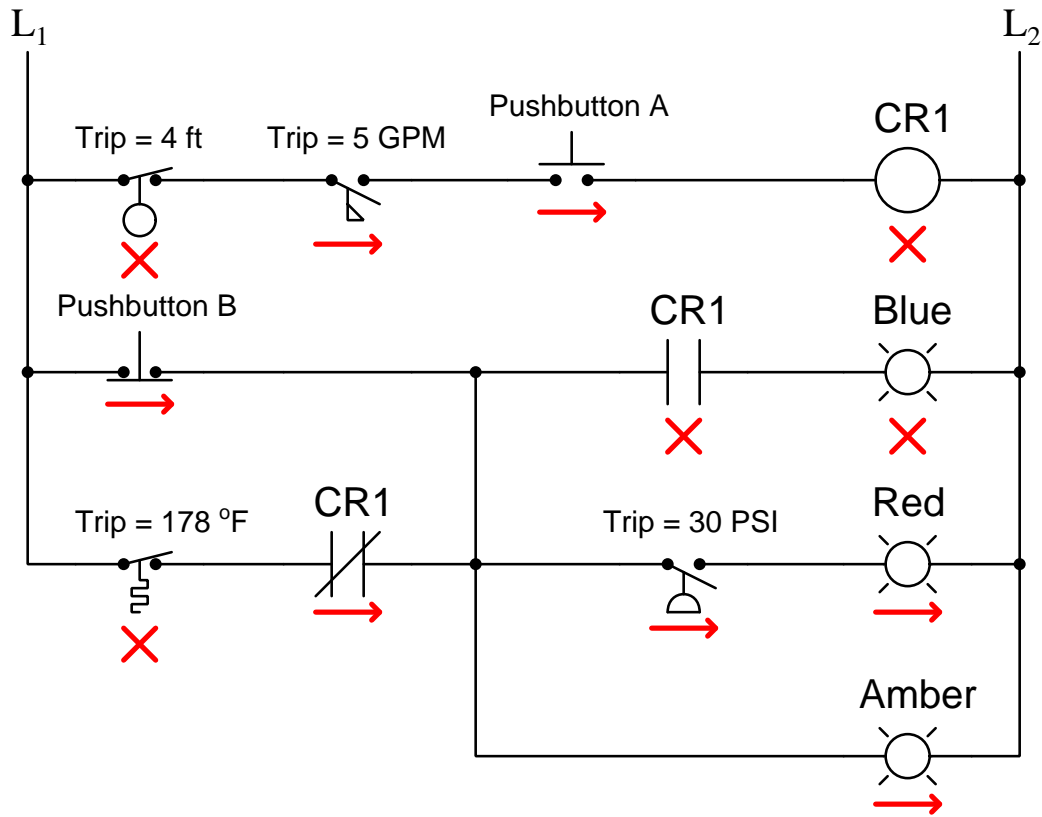

Recall that a process switch will be in its resting (“normal”) condition when the stimulus value is less than the trip threshold, and will be in its actuated condition when the stimulus exceeds the threshold.

Therefore,

- CR1 coil = **de-energized**
- Blue lamp = **de-energized**
- Red lamp = **energized**
- Amber lamp = **energized**

Answer 15

This is just one possible solution:

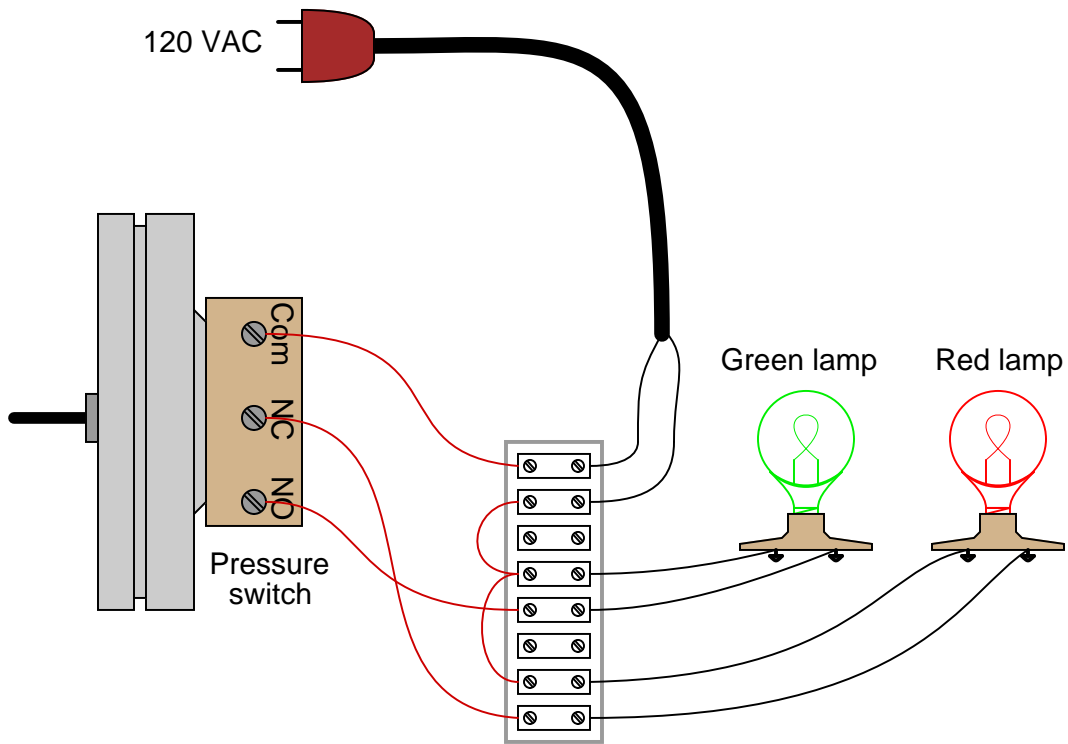

Answer 16

This is a graded question – no answers or hints given!

This is just one possible solution:

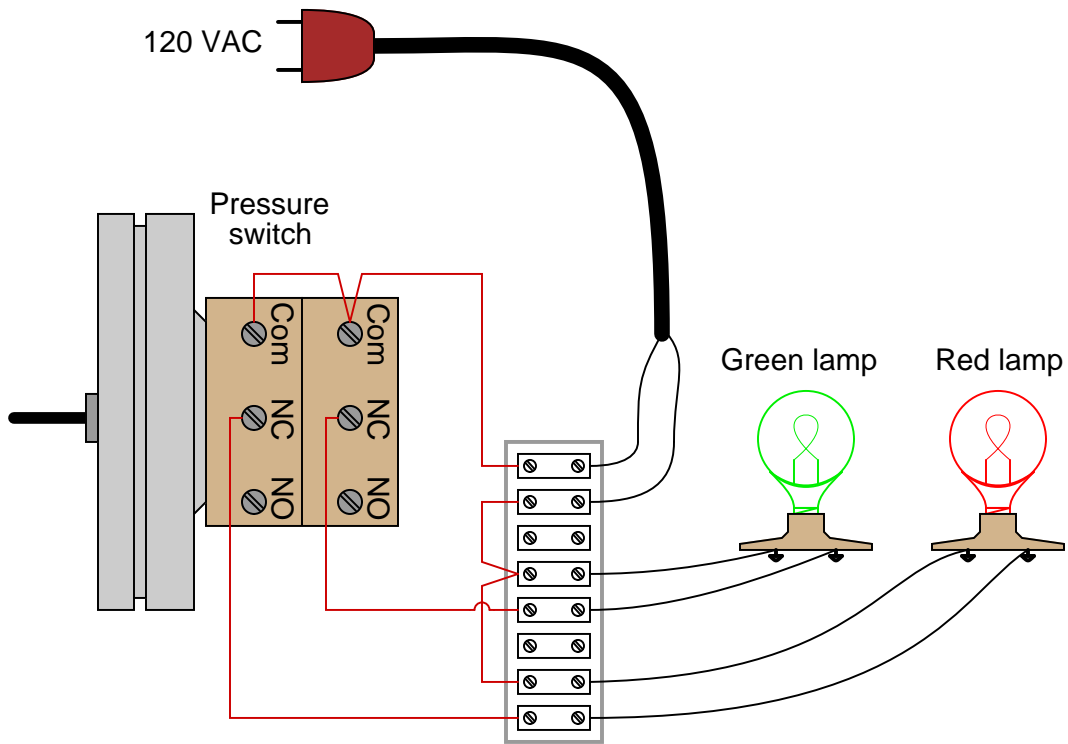

Answer 18

This is just one possible solution:

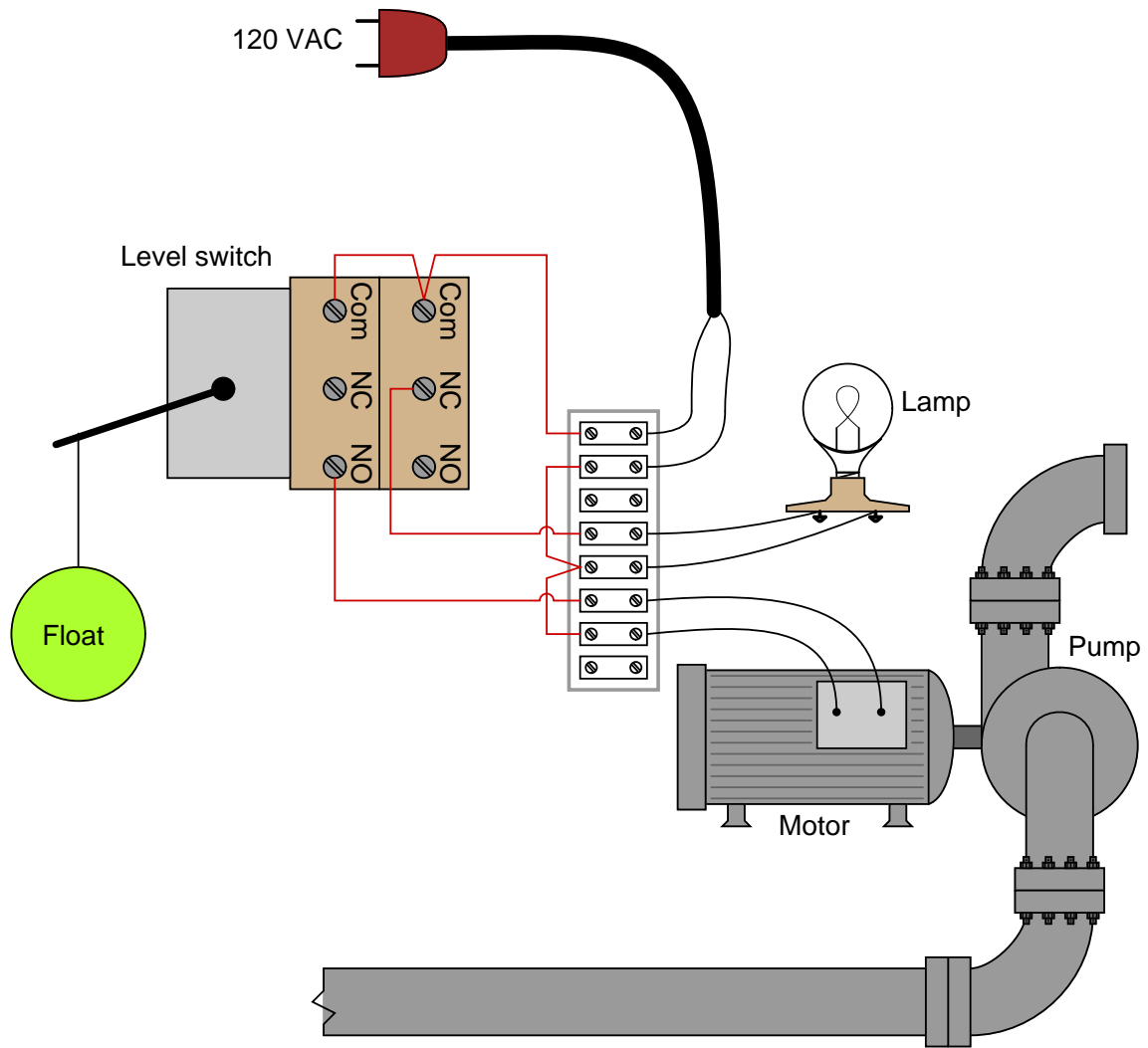

Answer 19

The blue lamp will be energized whenever the pressure switch senses a pressure that is less than 45 PSI.

The red and green lamps will both be de-energized whenever the level senses a level less than 1 foot 3 inches. If that switch senses a level greater than 1 foot 3 inches, either the red lamp or the green lamp will energize (not both simultaneously!) based on the pressure switch's state: a pressure less than 45 PSI energizes the relay coil and energizes the green lamp, while a pressure greater than 45 PSI de-energizes the relay coil and energizes the red lamp.

Answer 20

If you thought the overload heaters would open up like fuses in the event of an overload condition (becoming too warm) to directly interrupt motor current, you have made a very common error! Don't feel bad, though – I won't tell anyone.

In order for the overload assembly to automatically shut down the motor, its small switch must be connected to something. I'll let you figure out what that something is!

Answer 21

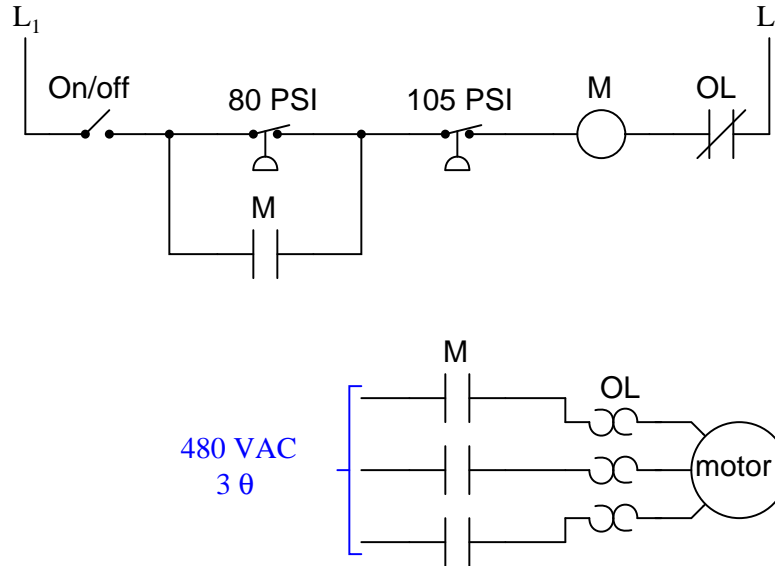

Answer 22

Be sure to review the operation of this simple motor start-stop circuit in your answer!